

ENGINE

TRE224

**IT Motore - MANUALE DI ISTRUZIONI**

ATTENZIONE: prima di usare la macchina, leggere attentamente il presente libretto.

BG Мотора - УПЪТВАНЕ ЗА УПОТРЕБА

ВНИМАНИЕ: преди да използвате машината прочетете внимателно настоящата книжна.

BS Motora - UPUTSTVO ZA UPOTREBU

PAŽNJA: prije nego što koristite ovu mašinu, pažljivo pročitaite priručnik s uputama.

CS Motoru - NÁVOD K POUŽITÍ

UPOZORNĚNÍ: před použitím stroje si pozorně přečtete tento návod k použití.

DA Motor - BRUGSANVISNING

ADVARSEL: læs instruktionsbogen omhyggeligt igennem, før du tager denne maskine i brug.

DE Motor - GEBRAUCHSANWEISUNG

ACHTUNG: vor inbetriebnahme des geräts die gebrauchsanleitung aufmerksam lesen.

EL κινητήρα - ΟΔΗΓΙΕΣ ΧΡΗΣΗΣ

ΠΡΟΣΟΧΗ: πριν χρησιμοποιήσετε το μηχάνημα, διαβάστε προσεκτικά το παρόν εγχειρίδιο.

EN Engine - OPERATOR'S MANUAL

WARNING: read thoroughly the instruction booklet before using the machine.

ES Motor - MANUAL DE INSTRUCCIONES

ATENCIÓN: antes de utilizar la máquina, leer atentamente el presente manual.

ET Mootori - KASUTUSJUHEND

TÄHELEPANU: enne masina kasutamist lugea tähelepanelikult antud kasutusjuhendit.

FI Moottoriin - KÄYTTÖOHJEET

VAROITUS: lue käyttöohjas huolellisesti ennen koneen käyttöä.

FR Moteur - MANUEL D'UTILISATION

ATTENTION: lire attentivement le manuel avant d'utiliser cette machine.

HR Motora - PRIRUČNIK ZA UPORABO

POZOR: prije uporabe stroja, pažljivo pročitaite ovaj priručnik.

HU Motor - HASZNÁLATI UTASÍTÁS

FIGYELEM! a gép használatá előtt olvassa el figyelmesen a jelen kézikönyvet.

LT Variklio - NAUDOJIMO INSTRUKCIJOS

DĖMESIO: prieš naudojant įrenginį, atidžiai perskaityti šį naudotojo vadovą.

LV Dzinēja - LIETOŠANAS INSTRUKCIJA

UZMANĪBU: pirms aparāta lietošanai rūpīgi izlasiet doto instrukciju.

MK Моторот - УПАТСТВА ЗА УПОТРЕБА

ВНИМАНИЕ: прочитаите го внимателно ова упатство пред да ја користите машината.

NL Motor - GEBRUIKERSHANDLEIDING

LET OP: vooraleer de machine te gebruiken, dient men deze handleiding aandachtig te lezen.

NO Motoren - INSTRUKSJONSBOK

ADVARSEL: les denne bruksanvisningen nøye før du bruker maskinen.

PL Silnika - INSTRUKCJE OBSŁUGI

OSTRZEŻENIE: przed użyciem maszyny, należy uważnie przeczytać niniejszą instrukcję.

PT Motor - MANUAL DE INSTRUÇÕES

ATENÇÃO: antes de usar a máquina, leia atentamente o presente manual.

RO Motor - MANUAL DE INSTRUCȚIUNI

ATENȚIE: înainte de a utiliza mașina, citiți cu atenție manualul de față.

RU двигателя - РУКОВОДСТВО ПО ЭКСПЛУАТАЦИИ

ВНИМАНИЕ: прежде чем пользоваться оборудованием, внимательно прочтите это руководство по эксплуатации.

SK Motora - NÁVOD NA POUŽITIE

UPOZORNENIE: pred použitím stroja si pozorne prečítajte tento návod.

SL Motorja - PRIROČNIK ZA UPORABO

POZOR: preden uporabite stroj, pazljivo preberite priročnik z navodili.

SR Motora - PRIRUČNIK SA UPUTSTVIMA

PAŽNJA: pre korišćenja mašine pažljivo pročitaite ovaj priručnik.

SV Motor - BRUKSANVISNING

VARNING: läs igenom hela detta häfte innan du använder maskinen.

TR Motor - KULLANIM KILAVUZU

DİKKAT: makineyi kullanmadan önce talimatlar ıçeren kilavuzu dikkatle okuyun.

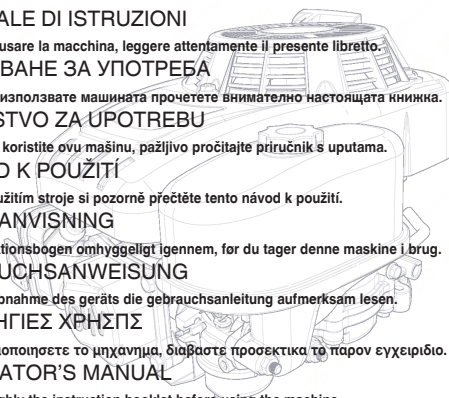

ITALIANO - Istruzioni Originali	IT
БЪЛГАРСКИ - Инструкция за експлоатация	BG
BOSANSKI - Prijevod originalnih uputa	BS
ČESKY - Překlad původního návodu k používání	CS
DANSK - Oversættelse af den originale brugsanvisning	DA
DEUTSCH - Übersetzung der Originalbetriebsanleitung	DE
ΕΛΛΗΝΙΚΑ - Μεταφραση των πρωτοτυπων οδηγιων	EL
ENGLISH - Translation of the original instruction	EN
ESPAÑOL - Traducción del Manual Original	ES
EESTI - Algupärase kasutusjuhendi tõlge	ET
SUOMI - Alkuperäisten ohjeiden käännös	FI
FRANÇAIS - Traduction de la notice originale	FR
HRVATSKI - Prijevod originalnih uputa	HR
MAGYAR - Eredeti használati utasítás fordítása	HU
LIETUVIŠKAI - Originalių instrukcijų vertimas	LT
LATVIEŠU - Instrukciju tulkojums no oriģināl valodas	LV
МАКЕДОНСКИ - Превод на оригиналните упатства	MK
NEDERLANDS - Vertaling van de oorspronkelijke gebruiksaanwijzing	NL
NORSK - Oversettelse av den originale bruksanvisningen	NO
POLSKI - Tłumaczenie instrukcji oryginalnej	PL
PORTUGUÊS - Tradução do manual original	PT
ROMÂN - Traducerea manualului fabricantului	RO
РУССКИЙ - Перевод оригинальных инструкций	RU
SLOVENSKY - Preklad pôvodného návodu na použitie	SK
SLOVENŠČINA - Prevod izvirnih navodil	SL
SRPSKI - Prevod originalnih uputstva	SR
SVENSKA - Översättning av bruksanvisning i original	SV
TÜRKÇE - Orijinal Talimatların Tercümesi	TR

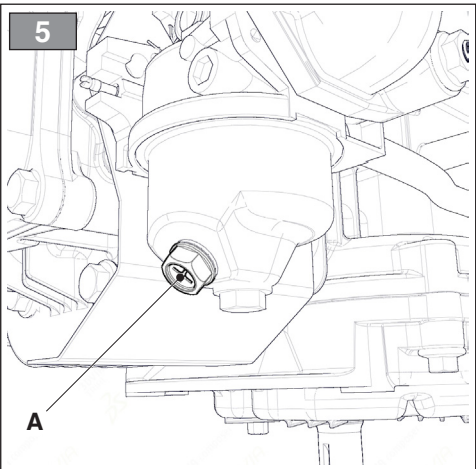
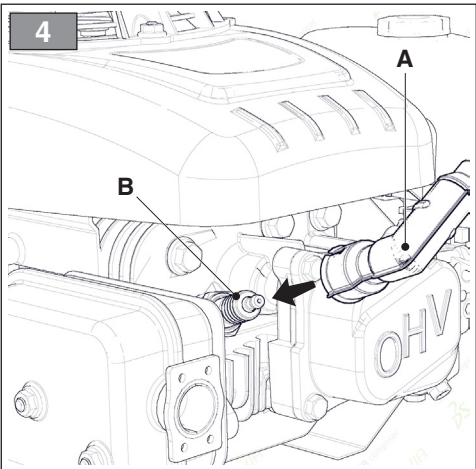
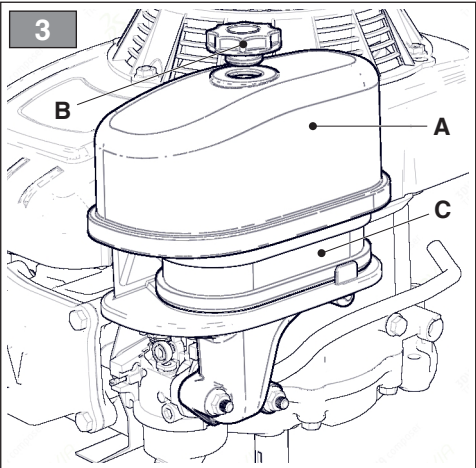
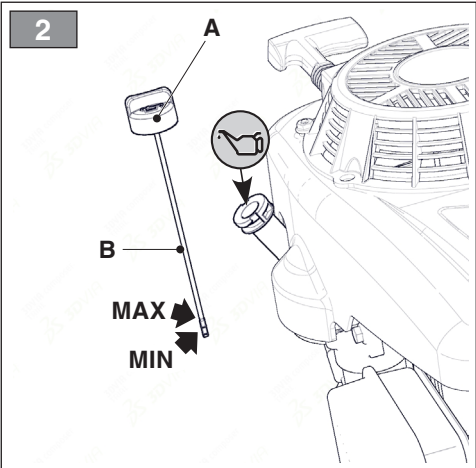
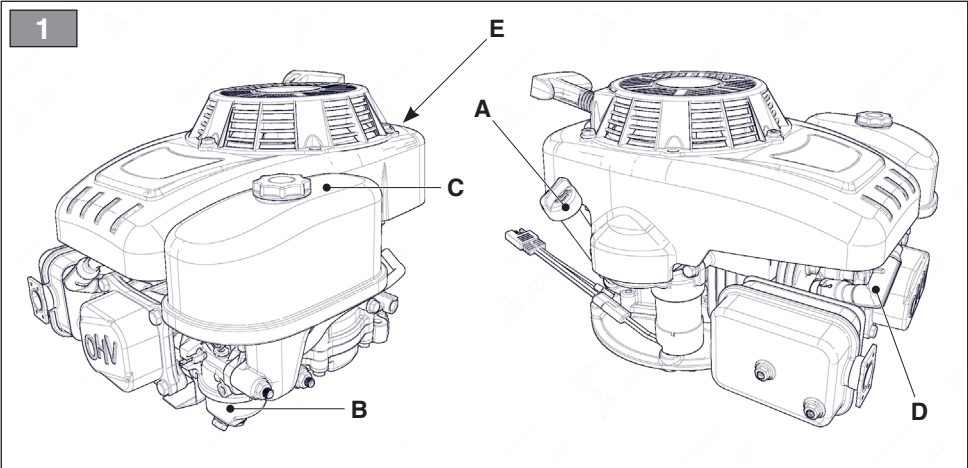

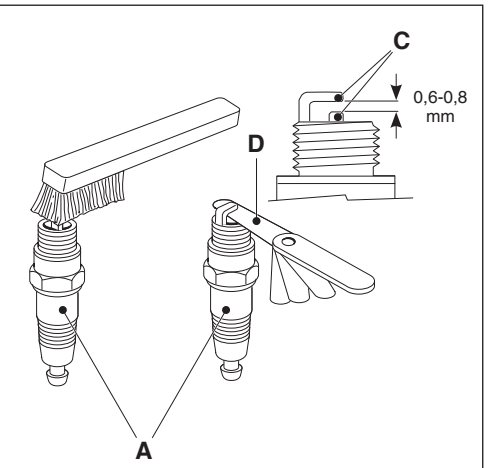
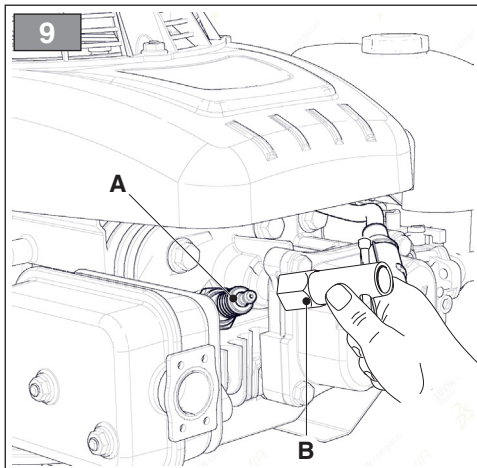
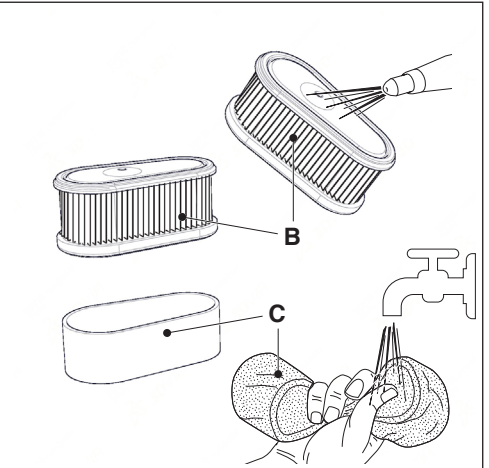
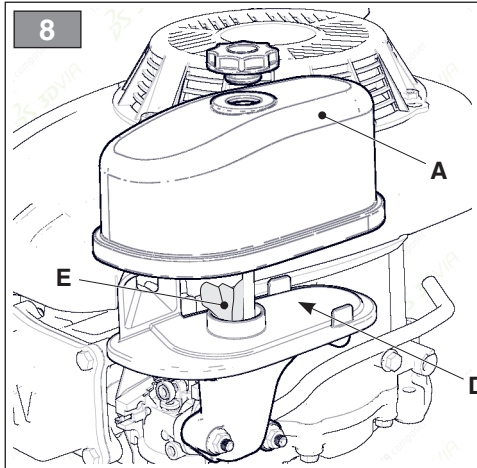
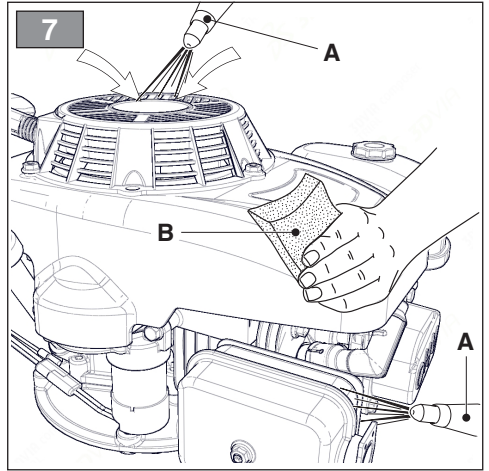
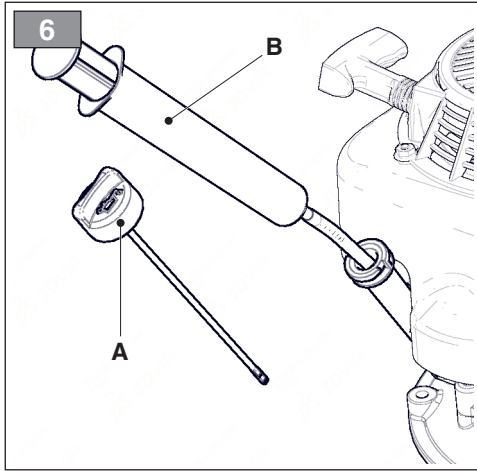

[1]	DATI TECNICI	model	TRE224
[2]	Carburante	tipo	unleaded fuel 90 RON
[3]	Olio motore	tipo	da 5 a 35 °C SAE 30; da -15 a +35 °C 10W-30
[4]	Contenuto della coppa	lit	0,5
[5]	Candela	tipo	GGP K7RTC / Champion RC12YC
[6]	Distanza fra gli elettrodi	mm	0,6 - 0,8
[7a]	CO ₂	g/kWh	891,86
[7b]	Questo è il valore di misurazione del CO ₂ risultato da un ciclo di prova fisso eseguito in condizioni di laboratorio su un motore (capostipite) rappresentativo del tipo di motore (della famiglia di motori) e non comporta alcuna garanzia implicita o esplicita o delle prestazioni di un particolare motore		

<p>[1] BG - ТЕХНИЧЕСКИ ДАННИ</p> <p>[2] Гориво</p> <p>[3] Моторно масло</p> <p>[4] Вместимост на картера</p> <p>[5] Запалителна свещ</p> <p>[6] Разстояние между електродите</p> <p>[7a] CO₂</p> <p>[7b] Това измерване на CO₂ е направено в хода на изпитване в рамките на фиксиран цикъл на изпитване при лабораторни условия на (базов) двигател, представителен за типа двигател (фамилията двигателя), и не означава косвена или изрична гаранция за работата на конкретен двигател.</p>	<p>[1] BS - TEHNIČKI PODACI</p> <p>[2] Gorivo</p> <p>[3] Motorno ulje</p> <p>[4] Sadržaj posude</p> <p>[5] Svjećica</p> <p>[6] Razdaljina između elektroda</p> <p>[7a] CO₂</p> <p>[7b] Ovo mjerenje CO₂ nastalo je na temelju testiranja provedenog tokom fiksnog ciklusa testiranja u laboratorijskim uvjetima i predstavlja vrstu motora (serija motora) te ne uključuje i ne izražava bilo kakvu garanciju performansi određene motora.</p>	<p>[1] CS - TECHNICKÉ PARAMETRY</p> <p>[2] Palivo</p> <p>[3] Motorový olej</p> <p>[4] Obsah klíčové skříně motoru</p> <p>[5] Svíčka</p> <p>[6] Vzdálenost mezi elektrodami</p> <p>[7a] CO₂</p> <p>[7b] Toto měření CO₂ je výsledkem zkoušek o stanoveném počtu zkušebních cyklů v laboratorních podmínkách na (základním) motoru reprezentativním pro typ motoru (rodinu motorů) a nepředstavuje ani nevyjadřuje záruku výkonosti konkrétního motoru.</p>
<p>[1] DA - TEKNISKE DATA</p> <p>[2] Brændstof</p> <p>[3] motorolie</p> <p>[4] Indhold af oliefanger</p> <p>[5] Tændrør</p> <p>[6] Afstand mellem elektroderne</p> <p>[7a] CO₂</p> <p>[7b] Denne CO₂-måling hidrører fra prøvning ved en fast prøvningscyklus under laboratorieforhold af en (stam)motor, der er repræsentativ for motortypen (motorfamilien), og hverken indebærer eller udtrykker en garanti for en bestemt motors ydelse.</p>	<p>[1] DE - TECHNISCHE DATEN</p> <p>[2] Kraftstoff</p> <p>[3] Motoröl</p> <p>[4] Fassungsvermögen der Wanne</p> <p>[5] Zündkerze</p> <p>[6] Abstand zwischen den Elektroden</p> <p>[7a] CO₂</p> <p>[7b] Diese CO₂-Messung ist das Ergebnis der Erprobung eines für den Motortyp bzw. die Motorenfamilie repräsentativen (Stamm-)Motors in einem festen Prüfzyklus unter Laborbedingungen und stellt keine ausdrückliche oder implizite Garantie der Leistung eines bestimmten Motors dar.</p>	<p>[1] EL - ΤΕΧΝΙΚΑ ΧΑΡΑΚΤΗΡΙΣΤΙΚΑ</p> <p>[2] Καύσιμο</p> <p>[3] Λάδι κινητήρα</p> <p>[4] Περιεχόμενο του κυπέλλου</p> <p>[5] Μπουζί</p> <p>[6] Απόσταση ηλεκτροδίων</p> <p>[7a] CO₂</p> <p>[7b] Η μέτρηση CO₂ προέρχεται από τη δοκιμή ενός (μητρικού) κινητήρα αντιπροσωπευτικού του τύπου κινητήρων (της σειράς κινητήρων) κατά τη διάρκεια ενός προκαθορισμένου κύκλου δοκιμών υπό εργαστηριακές συνθήκες και δεν συνιστά, ρητά ή σιωπηρά, οποιοδήποτε είδους εγγύηση αναφορικά με τις επιδόσεις ενός συγκεκριμένου κινητήρα.</p>

<p>[1] EN - TECHNICAL DATA [2] Fuel [3] Engine oil [4] Oil capacity [5] Spark plug [6] Electrode gap [7a] CO₂ [7b] This CO₂ measurement results from testing over a fixed test cycle under laboratory conditions a(n) (parent) engine representative of the engine type (engine family) and shall not imply or express any guarantee of the performance of a particular engine.</p>	<p>[1] ES - DATOS TÉCNICOS [2] Combustible [3] Aceite del motor [4] Contenido del cárter [5] Bujía [6] Distancia entre los electrodos [7a] CO₂ [7b] La presente medición de CO₂ es el resultado de ensayos realizados durante un ciclo de ensayo fijo en condiciones de laboratorio con un motor (de referencia) representativo del tipo de motor (familia de motores) de que se trate y no constituye garantía alguna ni implícita ni expresa del rendimiento de un motor concreto.</p>	<p>[1] ET - TEHNILISED ANDMED [2] Kütus [3] Mootoriõli [4] Kogus [5] Küünal [6] Vahe elektroodide vahel [7a] CO₂ [7b] Käesolevad CO₂ mõõtetulemused on saadud laboratoorses tingimustes püsikatsetsükli sõidukiitüüpi (mootoritüüpkinda) esindava representatiiv(alg) mootori peal ning ei anna ega väljenda mingit garantiid konkreetse mootori talitluse kohta</p>
<p>[1] FI - TEKNISET TIEDOT [2] Polttoaine [3] Mootoriöljy [4] Öljysäiliön tilavuus [5] Sytytystulppa [6] Elektrodienväli [7a] CO₂ [7b] Tämä CO₂-mittaustulos on saatu moottorityypistä (moottoriperhettä) edustavalle (kanta)moottorille laboratorio-olosuhteissa tehdystä kiinteässä testisyklissä, eikä se ole tae yksittäisen moottorin suorituskyvystä.</p>	<p>[1] FR - CARACTÉRISTIQUES TECHNIQUES [2] Carburant [3] Huile moteur [4] Contenu du bac à huile [5] Bougie [6] Distance entre les électrodes [7a] CO₂ [7b] Cette mesure du CO₂ est le résultat d'un essai, réalisé sur un cycle fixe dans des conditions de laboratoire, portant sur un moteur [parent] représentatif du type de moteurs [de la famille de moteurs], et ne constitue pas une indication ou une garantie des performances d'un moteur particulier.</p>	<p>[1] HR - TEHNIČKI PODACI [2] Gorivo [3] Motorno ulje [4] Sadržaj posude [5] Svjećica [6] Udaljenost između elektroda [7a] CO₂ [7b] Ova izmjerenja vrijednost CO₂ rezultat je ispitivanja tijekom određenog ispitnog ciklusa u laboratorijskim uvjetima te ne podrazumijeva nikakvo implicitno ili izričito jamstvo o sposobnosti određenog motora.</p>
<p>[1] HU - MŰSZAKI ADATOK [2] Üzemanyag [3] Motorolaj [4] Olajteknő kapacitás [5] Gyertya [6] Elektroódok közötti távolság [7a] CO₂ [7b] Ez a CO₂-érték a motor-típust (motorcsaládot) képviselő (alap)motoron, rögzített vizsgálati ciklus alatt, laboratóriumi körülmények között elvégzett vizsgálatból származik, és sem kifejezetten, sem hallgatólagosan nem jelent garanciát az adott motor teljesítményére vonatkozóan</p>	<p>[1] LT - TECHINIAI DUOMENYS [2] Degalai [3] Variklio alyvos [4] Duginės talpa [5] Žvakės [6] Atstumas nuo elektrodo [7a] CO₂ [7b] Šis CO₂ matavimo rezultatai gauti atliekant nustatytą bandymų ciklą laboratorinėmis sąlygomis su (pirminiu) varikliu, atitinkančiu variklio tipą (variklio šeimą), ir jie neužtikrina ir negarantuoja konkretaus variklio eksploatacinių charakteristikų.</p>	<p>[1] LV - TEHNISKIE DATI [2] Degviela [3] Motoreļļa [4] Kausa saturs [5] Svece [6] Attālums starp elektrodiem [7a] CO₂ [7b] Šis CO₂ mērījumu rezultāts iegūts, testējot motora tipu (motoru saimi) pārstāvošo (cilmes) motoru fiksētā testa ciklā laboratorijas apstākļos, un nedrīkst netieši norādīt vai izteikt jebkādu garantijas izpildījumu attiecībā uz konkrēto motoru.</p>

<p>[1] МК - ТЕХНИЧКИ ПОДАТОЦИ</p> <p>[2] Гориво</p> <p>[3] Моторно масло</p> <p>[4] Капацитет на резервоарот за масло</p> <p>[5] Свеќичка</p> <p>[6] Расстојание помеѓу електродите</p> <p>[7a] CO₂</p> <p>[7b] Ова мерење на CO₂ е резултат на тестирање преку фиксен циклусен тест во лабораториски услови на (матичен) мотор кој е претставен на типот на моторот (фамилијата на моторот) и не треба да имплицира ниту да изразува каква било гаранција за изведбата на одреден мотор.</p>	<p>[1] NL - TECHNISCHE GEGEVENS</p> <p>[2] Brandstof</p> <p>[3] Motorolie</p> <p>[4] Inhoud van de carter</p> <p>[5] Bougie</p> <p>[6] Afstand tussen de elektroden</p> <p>[7a] CO₂</p> <p>[7b] Deze meetresultaten voor CO₂ betreffen metingen volgens een vaste testcyclus onder laboratoriumomstandigheden, gedaan op een (basis)motor die representatief is voor het betrokken motortype (de betrokken motorfamilie); zij impliceren of vormen geen enkele garantie voor de prestaties van een bepaalde motor.</p>	<p>[1] NO - TEKNISKE DATA</p> <p>[2] Drivstoff</p> <p>[3] Motorolje</p> <p>[4] Beholderens volum</p> <p>[5] Tennplugg</p> <p>[6] Avstand mellom elektrodene</p> <p>[7a] CO₂</p> <p>[7b] Dette er verdien for måling av verdien for CO₂ resultat av en fast testsyklus utført under forhold som på laboratorium av en motor (overordnet) representativ for motortypen (av motorfamilien) og innebærer ingen implisitt eller eksplisitt garanti eller prestasjonene til en gitt motor.</p>
<p>[1] PL - DANE TECHNICZNE</p> <p>[2] Paliwo</p> <p>[3] Olej silnikowy</p> <p>[4] Pojemność miski olejowej</p> <p>[5] Świeca</p> <p>[6] Odległość między elektrodami</p> <p>[7a] CO₂</p> <p>[7b] Podany wynik pomiaru CO₂ pochodzi z badania przeprowadzonego na silniku (macierzystym) będącym przedstawicielem typu (rodziny) silników w czasie stałego cyklu badania w warunkach laboratoryjnych i pomiar ten nie oznacza ani nie stanowi żadnej gwarancji osiągnięć danego silnika.</p>	<p>[1] PT - DADOS TÉCNICOS</p> <p>[2] Combustível</p> <p>[3] Óleo do motor</p> <p>[4] Conteúdo da taca</p> <p>[5] Vela de ignição</p> <p>[6] Distância entre os eletrodos</p> <p>[7a] CO₂</p> <p>[7b] A presente medição de CO₂ resulta do ensaio, durante um ciclo de ensaio fixo em condições de laboratório, realizado com um motor (precursor) representativo do tipo de motor (família de motores) e não implica nem expressa qualquer garantia do desempenho de um motor específico.</p>	<p>[1] RO - DATE TEHNICE</p> <p>[2] Carburant</p> <p>[3] Ulei de motor</p> <p>[4] Conținutul cupei</p> <p>[5] Bujie</p> <p>[6] Distanța dintre electrozi</p> <p>[7a] CO₂</p> <p>[7b] Aceste rezultate ale măsurărilor emisiilor de CO₂ au fost obținute în urma încercării pe durata unui ciclu de încercare fix în condiții de laborator a unui motor reprezentativ pentru tipul de motor (familie de motoare) și nu sugerează și nici nu exprimă o garanție privind performanța unui anumit motor.</p>
<p>[1] RU - ТЕХНИЧЕСКИЕ ХАРАКТЕРИСТИКИ</p> <p>[2] Топливо</p> <p>[3] Моторное масло</p> <p>[4] Содержимое маслосборника</p> <p>[5] Свеча</p> <p>[6] Расстояние между электродами</p> <p>[7a] CO₂</p> <p>[7b] Данное измерение величины CO₂ было получено в результате фиксированного цикла испытаний в лабораторных условиях двигателя (исходного), который представляет тип (семейство) двигателей. Оно не является гарантией эксплуатационных характеристик конкретного двигателя</p>	<p>[1] SK - TECHNICKÉ PARAMETRE</p> <p>[2] Palivo</p> <p>[3] Motorový olej</p> <p>[4] Obsah olejovej vane</p> <p>[5] Sviečka</p> <p>[6] Vzdialenosť medzi elektrodami</p> <p>[7a] CO₂</p> <p>[7b] Toto meranie CO₂ sa dosiahlo pri stálom skúšobnom cykle v laboratórnych podmienkach na typickom (základnom) motore typu (radu) motorov a nepredstavuje žiadnu záruku vlastností konkrétneho motora.</p>	<p>[1] SL - TEHNIČNI PODATKI</p> <p>[2] Gorivo</p> <p>[3] Motorno olje</p> <p>[4] Vsebina skledice</p> <p>[5] Svečka</p> <p>[6] Razdalja med elektrodama</p> <p>[7a] CO₂</p> <p>[7b] Ta meritev CO₂ izhaja iz preskušanja, opravljenega v skladu s toÅno doloÅnim preskusnim ciklom v laboratorijskih pogojih na (osnovnem) motorju, ki je reprezentativen za tip motorja (družino motorjev), in ne pomeni nikakršnega jamstva glede značilnosti doloÅenega motorja.</p>

<p>[1] SR - TEHNIČKI PODACI</p> <p>[2] Gorivo</p> <p>[3] Motorno ulje</p> <p>[4] Sadržaj posude</p> <p>[5] Svećica</p> <p>[6] Udaljenost između elektroda</p> <p>[7a] CO₂</p> <p>[7b] Ovo je izmerena vrednost ugljen-dioksida koja predstavlja rezultat ciklusa ispitivanja izvršenog u laboratorijskim uslovima na motoru (začetniku serije) koji je predstavnik tipa motora (iz iste serije motora) i ne obuhvata podrazumevanu ili izričitu garanciju performansi za određeni motor.</p>	<p>[1] SV - TEKNISKA SPECIFIKATIONER</p> <p>[2] Bränsle</p> <p>[3] Motorolja</p> <p>[4] Volym i tråget</p> <p>[5] Tändstift</p> <p>[6] Avstånd mellan elektroderna</p> <p>[7a] CO₂</p> <p>[7b] Denna CO₂-mätning kommer från den provade (huvud)motorn i motortypen (motorfamiljen) och har gjorts under en fast provcykel i laboratorieförhållanden. Den innebär inte och uttrycker inte någon garanti för prestanda hos en viss motor.</p>	<p>[1] TR - TEKNİK VERİLER</p> <p>[2] Yakıt</p> <p>[3] Motor yağı</p> <p>[4] Kap hacmi</p> <p>[5] Buji</p> <p>[6] Elektrodlar arasındaki mesafe</p> <p>[7a] CO₂</p> <p>[7b] Bu CO₂ ölçümü, motor tipini (motor ailesini) temsil eden bir (ana) motorun laboratuvar koşulları altında sabit bir test döngüsünde test edilmesi sonucunda elde edilir ve belirli bir motorun performansı konusunda açık ya da örtülü herhangi bir garanti ifade etmez.</p>
--	---	--



INDEX

1. GENERAL INFORMATION.....	1
2. SAFETY REGULATIONS.....	1
3. ABOUT THE MACHINE.....	3
3.1 Machine description and intended use..	3
3.2 Safety signs	3
3.3 Identification label	3
3.4 Engine components	3
3.5 Environmental conditions	4
3.6 Fuel	4
3.7 Oil	4
3.8 Air filter	4
3.9 Spark plug.....	4
4. CONTROLS.....	4
4.1 Accelerator control.....	4
5. REGULATIONS FOR USE.....	5
5.1 Before each use	5
5.2 Starting the engine (cold start)	5
5.3 Starting the engine (warm start)	5
5.4 Engine use during operation	5
5.5 Stopping the engine during operation ...	6
5.6 Stopping the engine at the end of operation.....	6
5.7 Cleaning and storage	6
5.8 Prolonged downtime	6
6. MAINTENANCE	6
6.1 General	6
6.2 Maintenance table.....	6
6.3 Oil change.....	7
6.4 Cleaning the silencer and the engine	7
6.5 Air filter maintenance	7
6.6 Spark plug checks and maintenance	7
7. TROUBLESHOOTING.....	8

1. GENERAL INFORMATION

1.1 HOW TO READ THIS MANUAL

Some of the paragraphs in this manual contain particularly important information in terms of safety and operation, and are highlighted differently, according to the following criteria:

NOTE or **IMPORTANT** *this paragraph provides details or further information on what has already been said, with the aim of preventing damage to the machine or other damage.*

The  symbol represents a danger. Failure to observe the warning can lead to possible personal and/or third party injury and/or damage.

1.2 REFERENCES

1.2.1 Figures

The figures in these instructions for use are numbered 1, 2, 3, and so forth. The components identified in the figures are marked with letters A, B C and so forth. A reference to component C in figure 2 is represented by: "See fig. 2.C" or simply "(Fig. 2.C)".

The figures are provided by way of example. The effective prices can vary in comparison to the ones provided here.

1.2.2 Titles

The manual is arranged in chapters and paragraphs. The title of paragraph "2.1 Training" is a sub-title of "2. Safety regulations". The references to titles or paragraphs are marked with the abbreviation chap. or par. and the relative number. Example: "chap. 2" or "par. 2.1".

2. SAFETY REGULATIONS

2.1 TRAINING

 **Read these instructions carefully before using the machine.**

 **Familiarise with the controls and with appropriate use of the machine. Learn how to stop the engine quickly. Failure to observe warnings and instructions can cause fires and/or serious injury. Keep all warnings and instructions safe for future reference.**

- Never allow the machine to be used by children or individuals who are not familiar with the instructions. Local laws may establish a minimum age for users.
- Never use the machine if the user is tired or unwell, or has taken medication, drugs, alcohol or substances that impair reflexes and concentration.
- Remember that the operator or user is responsible for accidents and unexpected events that can occur to other people or property.

2.2 PRELIMINARY OPERATIONS

Personal Protective Equipment (PPE)

- Never use the machine without wearing suitable clothing.
- Never wear loose clothing, laces, jewellery or other objects that can get caught; tie back long hair and maintain the safety distance at start-up.
- Wear noise cancelling headphones.

Work / Machine Area

- Before starting the engine ensure that all of the controls operating the moving parts of the machine are disconnected.

Internal combustion engine: fuel

- Warning: the fuel is highly flammable. Handle with care!
 - Always store the fuel in suitable containers.
 - Fill up or top up using a funnel, only outdoors and never smoke during these operations.
 - Fill up before turning the engine on. Never open the tank cap or fill up when the engine is running or still warm.
 - If any fuel spills out do not start the engine, rather, move the machine away from the spillage and immediately clean up every trace of fuel that has spilled on to the machine or ground.
 - Firmly screw the fuel container tank cap back on.
 - Avoid getting any fuel or your clothing and, if this should happen, change your clothes before starting the engine.

2.3 DURING USE

Work Area

- Do not use the machine in environments that pose the risk of explosion, in the presence of flammable liquids, gases or powders. Electrical contact or mechanical rubbing can generate sparks that can ignite powder or vapour.
- Do not operate the engine in confined spaces where dangerous carbon monoxide fumes can collect. The start-up operations must be carried out outdoors or in a well-ventilated area. Always remember that the exhaust gases are toxic.
- Keep people, children and animals away from the work area. Children must be supervised by another adult.

Conduct

- Before making repairs, cleaning, performing inspections, adjustments, turn the engine off and disconnect the spark plug cable (unless explained otherwise in the instructions).
- Do not touch the parts of the engine that heat up during operation. Risk of burns.

Restrictions of use

- Do not use the machine if there are not enough protections or if the safety devices are not set up correctly.
- Do not disconnect or tamper with the installed safety systems.
- Do not change the engine adjustments, or exceed the maximum rpm. If the engine is forced to run at an excessive speed, the risk of personal injury increases.
- Do not use starter fluids or other similar products.
- Do not tilt the machine onto its side to the point where fuel leaks from the fuel tank cap.
- Do not crank the engine without spark plug.

2.4 MAINTENANCE, STORAGE AND TRANSPORT

Servicing the machine on a regular basis and correct storage maintain machine safety.

 **Broken or worn parts must be replaced and never repaired. Only use original parts: using parts that are not original or installed incorrectly affects machine safety, and can therefore cause accidents or personal injury and relieve the Manufacturer of all obligations and liability.**

Maintenance

- If the tank can be emptied, perform this operation outdoors and when the motor is cold.

- To reduce the risk of fire, check for oil and/or fuel leaks on a regular basis.

Storage

- Never leave fuel in the tank if the machine is stored in a building where the fuel vapours can come into contact with open flames, sparks or sources of heat.
- Let the machine cool down before storing it indoors.

Transport

- Transport the machine with an empty tank.

2.5 ENVIRONMENTAL PROTECTION

Protecting the environment must be a significant and top priority for machine use, to the benefit of civil co-habitation and of the environment that we live in.

- Avoid being an element of disturbance to the surrounding area.
- Follow local regulations closely for the disposal of packaging, oils, fuels, filters, worn parts or any element that strongly impacts the environment; this waste must not be disposed of with regular waste, but must be separated and taken to collection centres, who will recycle the materials.
- At the time of decommissioning, do not leave the machine in the environment, rather, contact a collection centre, in accordance with local regulations in force.

2.6 EMISSIONS

The combustion process generates toxic substances such as carbon monoxide, nitrogen oxides and hydrocarbons. It is important to control these substances because they can react with photochemical smog as well as with direct exposure to sunlight. Carbon monoxide does not react in the same way to exposure to sunlight but it must still be considered toxic.

Our machines are equipped with emission reduction systems for the substances mentioned above.

3. ABOUT THE MACHINE

3.1 MACHINE DESCRIPTION AND INTENDED USE

This machine is a spark-ignition engine

Engine performance, reliability and life are influenced by many factors, some external and some strictly associated with the quality of the employed products and with the scheduled maintenance. Additional information is provided below for greater awareness of your machine. Any other use that does not comply with the above, can be dangerous and cause damage to people and/or property.

IMPORTANT *Improper use of the machine causes the warranty to lapse and relieves the Manufacturer of any liability, placing all responsibility for damage or injury, to him/herself or third parties, on the user.*

3.1.1 Type of users

This machine is intended for use by consumers, i.e. non-professional operators. It is intended for "hobby-related activities"

3.2 SAFETY SIGNS

There are various symbols on the machine. Their function is to remind the operator of the correct conduct for use, with due care and caution.

Meanings of the symbols:



ATTENTION! The muffler may be very hot. Do not touch.



ATTENTION! Top up the oil until it reaches the «MAX» level. Do not exceed the «MAX» level.

3.3 IDENTIFICATION LABEL

Write the serial number (S7n) of your machine on the space provided on the label at the back of the cover.

3.4 ENGINE COMPONENTS

The machine is comprised of the following main parts (fig. 1).

- A. Oil filler cap with dipstick
- B. Carburettor
- C. Air filter cover
- D. Spark plug cap

E. Engine code

3.5 ENVIRONMENTAL CONDITIONS

The operation of a four-stroke endothermic engine is affected by:

a) Temperature:

- When operating at low temperatures cold starts may be difficult.
- When operating at very high temperatures warm starts may be difficult due to evaporation of the fuel in the float chamber of the carburettor or in the pump.
- In any case the right kind of oil must be used, according to the operating temperatures.

b) Altitude:

- The higher the altitude above sea level, the lower the max power developed by an endothermic engine.
- When there is a considerable increase in altitude, the load on the machine should be reduced and particularly heavy work avoided.

3.6 FUEL

A good quality fuel is the major issue for the engine reliability of operation.

Fuel must meet these requirements:

- Use clean, fresh unleaded gasoline, with a minimum of 90 octane.
- Do not use fuel formulated with ethanol greater than 10%.
- Do not add oil.
- To protect the fuel system from gum formation, mix a fuel stabilizer into the fuel.

Use of unapproved fuels will cause damage to engine components, which will not be covered under warranty.

NOTE *Only use the fuel named in the technical data table. Do not use other types of fuel. It is possible to use ecological fuels, such as alkylate petrol. The composition of this petrol has less of an impact on people and animals. No negative effects have been reported in connection to their use. Nonetheless, there are types of alkylate petrol on the market for which it is not possible to provide specific indications on their use.*

3.7 OIL

Use always high quality oils, choosing their viscosity grade according to the operating temperature.

- Only use detergent oil with a quality of no less than SF-SG.
- Choose the SAE viscosity based on the technical data table.
- The use of multigrade oil can lead to greater consumption in hot weather, accordingly it is necessary to check the level more frequently.
- Do not mix oils of different brands and characteristics.
- SAE 30 oil, if used below +5°C, could result in possible engine damage due to inadequate lubrication.

3.8 AIR FILTER

The air filter must always be in perfect working order, to prevent debris and dust from getting sucked into the engine, reducing the efficiency and life of the machine.

- Always keep the filtering element free of debris and in perfect working order (par. 6.5).
- If necessary, replace the filtering element with an original spare part. Incompatible filtering elements can impair the efficiency and life of the engine.
- Never start the engine without mounting the filtering element properly.

3.9 SPARK PLUG

Not all the spark plugs for endothermic engines are the same.

- Use only spark plugs of the recommended type, with the right heat range.
- Check the length of the thread, because - if too long - it will damage the engine beyond repair.
- Make sure that the electrodes are clean and that their gap is correct (par. 6.6).

4. CONTROLS

4.1 ACCELERATOR CONTROL

This controls engine rpm.

The throttle trigger (generally a lever), fitted to the machine, is connected to the engine by a cable.

Consult the machine's Instructions Manual to identify the throttle trigger and its positions, usually marked by symbols, corresponding to:

- **FAST** = corresponds to maximum revs; to be used when working.
- **SLOW** = corresponds to minimum revs.
- **CHOKE** = to be used for cold starts (when applicable)

5. REGULATIONS FOR USE

5.1 BEFORE EACH USE

Before every use, perform the following checking procedures in order to assure a regular operation. The fuel characteristics are provided in the specific paragraph (see 4.2 and 8.1).

5.1.1 Oil level check

1. Place the machine on a flat surface.
2. Clean around the oil fill cap.
3. Unscrew the cap (fig. 2.A), clean the end of the dipstick (fig. 2.B) and slide it back in until the cap is touching the hole, as shown, without screwing it back on.
4. Remove the cap with the dipstick and check the oil level that must be between the «MIN» and «MAX» marks.
5. If oil is required, add oil of the same kind up to the «MAX» mark, being careful not to spill any outside the oil fill.
6. Fully tighten the filler cap (fig. 2.A) and wipe off any spilled oil.

NOTE *Top up gradually, adding small amounts of oil, checking the level each time. Do not top up beyond the «MAX» level; an excessive level can cause:*

- *smoking from the exhaust;*
- *soiling of the spark plug or air filter with subsequent difficulty for ignition.*

NOTE *For the required type of oil, observe the indications provided in the technical data table.*

5.1.2 Air filter control

The efficiency of the air filter is essential to correct engine operation; do not start up the engine if there is no filtering element or it is broken.

1. Clean around the filter cover (fig. 3.A).
2. Take the cover off (fig. 3.A) by unscrewing the relative knob (fig. 3.B).
3. Check the state of the filtering element (fig. 3.C), which must be intact, clean

and in perfect working order; otherwise service or replace it (par. 6.5).

4. Put the cover back in place (fig. 3.A).

5.1.3 Refuelling

The refuelling operations are described in the machine manual and are mentioned here. To refuel:

1. Unscrew the fuel cap and take it off.
2. Set a funnel on the hole.
3. Refuel and take the funnel off.
4. At the end of refuelling, screw the cap back on and clean any spillage.

IMPORTANT *Avoid getting fuel on the plastic parts of the engine or machine to avoid damaging them, and immediately clean off every trace of spilled fuel. The warranty does not cover damage to plastic parts caused by fuel.*

5.1.4 Spark plug cap

Firmly connect the cap (fig. 4.A) of the spark plug cable (fig. 4.B), ensuring that there are no traces of dirt inside the cap or on the spark plug terminal.

5.2 STARTING THE ENGINE (COLD START)

The engine must be started up as described in the machine's Instructions Manual, always being careful to uncouple any device (if applicable) that is capable of making the machine travel forwards or stop the engine.

1. Place the throttle on «CHOKE» (if applicable) or «FAST».
2. Turn the starter key as described in the machine's Instructions Manual.

After a few seconds, gradually move the throttle from «CHOKE» (if applicable) to «FAST» or «SLOW».

5.3 STARTING THE ENGINE (WARM START)

Follow the entire procedure described for cold starts, with the throttle on «FAST».

5.4 ENGINE USE DURING OPERATION

To optimise engine output and performance, it must be used at maximum rpm, by placing the throttle on «FAST».

IMPORTANT *Do not work on slopes exceeding 20° to avoid jeopardising correct engine operation.*

5.5 STOPPING THE ENGINE DURING OPERATION

1. Place the throttle on «SLOW».
2. Let the engine run at minimum for at least 15-20 seconds.
3. Stop the engine following the instructions contained in the machine's Instructions Manual.

5.6 STOPPING THE ENGINE AT THE END OF OPERATION

1. Place the throttle on «SLOW».
2. Let the engine run at minimum for at least 15-20 seconds.
3. Stop the engine following the instructions contained in the machine's Instructions Manual.
4. With a cold engine, take the cap off the spark plug (fig. 4.A) and take out the starter key (if applicable).
5. Remove any debris from the engine and especially around the exhaust silencer to reduce the risk of fire.

5.7 CLEANING AND STORAGE

- Do not spray with water or use pressure washer wands to clean the exterior of the engine.
- Preferably use a compressed air gun (max. 6 bars), thus preventing debris and dust from penetrating inside.
- Store the lawnmower (and the engine) in a dry place, sheltered from the elements and sufficiently ventilated.

5.8 PROLONGED DOWNTIME

If the engine is not going to be used for more than 30 days (for example, at the end of the season), it will be necessary to take a few precautions so that it will start back up again accordingly.

- Empty the fuel tank, to avoid deposits from forming inside, by unscrewing the cap (fig. 5.A) of the fuel tank and collecting all of the fuel in a suitable container. At the end of this operation, remember to screw the cap back on (fig. 5.A) tightly.
- Remove the spark plug and pour about 3 cl of clean engine oil into the spark plug hole, then, having blocked the hole with a rag, run the starter motor briefly to turn the engine for

a few revs and distribute the oil over the inner surface of the cylinder. Finally, replace the spark plug without connecting the cable cap.

6. MAINTENANCE

⚠ *Any attempt to tamper with the emission control system may increase emission levels above legal limits. This definition includes the removal or alteration of parts such as the intake system, the fuel system and the exhaust system.*

6.1 GENERAL

⚠ *The safety regulations that must be followed during maintenance are described in par. 2.4.*

⚠ *All controls and maintenance operations must be carried out with the machine off and the engine off. Disconnect the spark plug and read the relative instructions before starting any cleaning or maintenance procedure. Wear suitable clothing, gloves and glasses before performing any maintenance.*

- The frequency and type of procedures are outlined in the "Maintenance table".
- The use of non-original parts and accessories could have negative effects on machine operation and safety. The manufacturer declines any responsibility for damage or injury caused by said products.
- Original parts are supplied by assistance shops and authorised dealers.

IMPORTANT *All maintenance and adjustment operations that are not described in this manual must be carried out by your Dealer or by a Specialised Centre.*

6.2 MAINTENANCE TABLE

IMPORTANT *It is the responsibility of the owner to perform the machine maintenance operations described in the table below.*

IMPORTANT *Clean more frequently when operating in particularly demanding conditions or when there is debris in the air.*

NOTE *Filters should be cleaned / replaced more often if the machine is used on very dusty ground.*

Operation	After the first 5 hours	Every 5 hours or after every use	Every 50 hours or at the end of the season	Every 100 hours
Oil level check (par. 5.1.1)	-	√	-	-
Oil change ¹ (par. 6.3)	√	-	√	-
Cleaning the silencer and the engine (par. 7)	-	√	-	-
Checking and cleaning the air filter ² (par. 8)	-	√	-	-
Changing the air filter (par. 8)	-	-	√	-
Spark plug check (par. 9)	-	-	√	-
Changing spark plugs (par. 9)	-	-	-	√
Fuel filter check ³	-	-	-	√

¹ Change the oil every 25 hours if the engine is operating under heavy load or in hot weather.

² Clean the air filter more frequently if the machine is operating in dusty areas.

³ To be carried out by a Specialised Centre.

6.3 OIL CHANGE

For the required type of oil, observe the indications provided in the technical data table.

⚠ Drain the oil out while the engine is warm, being careful not to touch the hot engine nor the drained oil.

Unless otherwise stated in this machine Instruction Manual, to change the oil it is necessary to:

1. Place the machine on a flat surface.
2. Clean around the filler cap and unscrew the cap with dipstick (fig. 6.A).
3. Place the nozzle of the relative syringe all the way (fig. 6.B) inside the oil tank and suck out the contents.
4. Top up with new oil (par. 5.1.1).

6.4 CLEANING THE SILENCER AND THE ENGINE

The silencer must be cleaned when the engine is cold.

- Use a jet of compressed air (fig. 7.A) to remove any debris and dirt that could cause a fire from the silencer and its protective cover.
- Ensure that the cooling air intakes are not obstructed (fig. 7.A).
- Clean the plastic parts with a sponge (fig. 7.B) soaked in water and detergent.

6.5 AIR FILTER MAINTENANCE

1. Clean around the filter cover (fig. 8.A).
2. Take the cover off (fig. 8.A) by removing the top screw.
3. Remove the filtering element (fig. 8.B + 8.C).
4. Take the pre-filter (fig. 8.C) out of the cartridge (fig. 8.B).
5. Tap the cartridge (fig. 8.B) on a solid surface and blow it from the inside with compressed air to remove dust and debris.
6. Wash the pre-filter sponge (fig. 8.C) with water and detergent and leave it to air dry.

IMPORTANT *Do not use water, petrol, detergents or any other products to clean the cartridge.*

IMPORTANT *The pre-filter sponge (fig. 8.C) must NOT be oiled.*

1. Clean out any dust and debris from inside the filter housing (fig. 8.D) being careful to close the extraction duct with a cloth (fig. 8.E) to stop them from getting into the engine.
2. Remove the cloth (fig. 8.E), place the filtering element (fig. 8.C + 8.B) in its housing and put the cover back in place (fig. 8.A).

6.6 SPARK PLUG CHECKS AND MAINTENANCE

1. Take the spark plug down (fig. 9.A) using a socket wrench (fig. 9.B).
2. Clean the electrodes (fig. 9.C) with a metal brush, removing any carbonaceous build-up.
3. Using a thickness gauge (fig. 9.D) ensure the gap between electrodes is correct (0.6 - 0.8 mm).
4. Put the spark plug back in (fig. 9.A) and tighten firmly using a socket wrench (fig. 9.B).

Replace the spark plug if the electrodes are burnt or if the porcelain is broken or damaged.

⚠ Fire hazard! Do not check the ignition system when the spark plug is not in place.

IMPORTANT *Only use the required type of spark plugs (see Technical data table).*

7. TROUBLESHOOTING

PROBLEM	PROBABLE CAUSE	SOLUTION
1. Difficulty starting the engine	No fuel	Check and top up (chap. 5.1.3)
	Old fuel or deposits in the fuel tank	Empty the fuel tank and add fresh fuel
	Incorrect starting procedure	Perform start-up correctly (par. 5.2 and par. 5.3)
	Disconnected spark plug	Ensure that the cap is fitted onto the spark plug (par. 5.1.4)
	The spark plug is wet or the spark plug electrodes are dirty or placed inadequately	Check (par. 6.6)
	Clogged air filter	Check and clean (par. 6.5)
	Incorrect oil for the season	Replace with suitable oil (par. 6.3)
	Fuel evaporation in the carburettor (vapor lock) due to elevated temperatures	Wait a few minutes then try starting it up again (par. 5.3)
	Carburation fault	Contact an Authorised Assistance Centre
	Ignition problems	Contact an Authorised Assistance Centre
2. Irregular operation	Dirty spark plug electrodes or incorrect gap	Check (par. 6.6)
	The spark plug cap inserted incorrectly	Ensure that the cap is firmly fitted on (par. 5.1.4)
	Clogged air filter	Check and clean (par. 6.5)
	Throttle on «CHOKE» (if applicable)	Move it to «FAST»
	Carburation fault	Contact an Authorised Assistance Centre
	Ignition problems	Contact an Authorised Assistance Centre
3. Loss of power during operation	Clogged air filter	Check and clean (par. 6.5)
	Carburation fault	Contact an Authorised Assistance Centre

If problems persist after implementing the solution, contact your Dealer.

IT • Il contenuto e le immagini del presente manuale d'uso sono stati realizzati per conto di ST. S.p.A. e sono tutelati da diritto d'autore – È vietata ogni riproduzione o alterazione anche parziale non autorizzata del documento.

BG • Съдържанието и изображенията в настоящото ръководство са извършени за ST. S.p.A. и са защитени с авторски права – Забранява се всяко неотризирано възпроизвеждане или промяна, дори и отчасти на документа.

BS • Sadržaj i slike iz ovog korisničkog priručnika napravljeni su isključivo za ST. S.p.A. i zaštićeni su autorskim pravima – zabranjena je svaka neovlaštena reprodukcija ili izmjena dokumenta, djelomično ili u potpunosti.

CS • Obsah a obrázky v tomto návodu k použití byly zpracovány jménem společnosti ST. S.p.A. a jsou chráněny autorským právem – Reprodukce či nepovolené pozměňování tohoto dokumentu, a to i částečné, je zakázáno.

DA • Indhold og illustrationer i denne vejledning er blevet skabt på vegne af ST. S.p.A. og er beskyttet af ophavsret – Enhver gengivelse eller ændring, også delvis, af dokumentet uden autorisation hertil er forbudt.

DE • Inhalt und Bilder dieser Bedienungsanleitung wurden im Namen von ST. S.p.A. erstellt und sind urheberrechtlich geschützt – Jede nicht genehmigte Vervielfältigung oder Veränderung, auch auszugsweise, dieses Dokuments ist verboten.

EL • Το περιεχόμενο και οι εικόνες στο παρόν εγχειρίδιο χρήσης δημιουργήθηκαν για λογαριασμό της εταιρείας ST. S.p.A. και προστατεύονται από πνευματικά δικαιώματα – Απαγορεύεται οποιαδήποτε αναπαραγωγή ή τροποποίηση, έστω και μερική, του εγχειρίδιου χωρίς έγκριση.

EN • The content and images in this User Manual were produced expressly for ST. S.p.A. and are protected by copyright – any unauthorised reproduction or modification to the document, either partially or in full, is prohibited.

ES • El contenido y las imágenes del presente manual de uso han sido creados por ST. S.p.A. y están protegidos por los derechos de autor – Se prohíbe toda reproducción o modificación, incluso parcial, no autorizada del documento.

ET • Käesoleva kasutusjuhendi sisu ja kujutised on toodetud konkreetselt ettevõttele ST. S.p.A. ja neile rakendub autoriõigusseseadus – dokumendi igasugune osaline või täielik ilma loata reprodutseerimine või muutmine on keelatud.

FI • Tämän käyttöoppaan sisältö ja kuvat on valmistettu ST. S.p.A. -yhtiön toimesta ja niitä suojaa tekijänoikeuslaki. – Asiakirjan kaikenlainen kopioiminen tai muuttaminen, osittainkin, on kielletty ilman erityistä lupaa.

FR • Le contenu et les images du présent manuel d'utilisation ont été réalisés pour le compte de ST. S.p.A. et sont protégés par un droit d'auteur – Toute reproduction ou modification non autorisée, même partielle, du document, est interdite.

HR • Sadržaj i slike u ovom priručniku za uporabu izrađeni su za tvrtku ST. S.p.A. te su obuhvaćeni autorskim pravima – Zabranjuje se neovlašteno umnožavanje ili prilagodba, djelomična ili u cijelosti, ovog dokumenta.

HU • Ennek a használati útmutatónak a tartalma és a benne szereplő képek kizárólag a ST. S.p.A. számára készültek és szerzői joggal védettek – tilos a dokumentum bármely részének vagy egészének engedély nélküli sokszorosítása és módosítása.

LT • Šio naudotojų vadovo turinys ir paveikslėliai skirti tik „ST. S.p.A.“ ir yra saugomi autorių teisėmis – dokumentą atgaminti ar modifikuoti, visiškai arba iš dalies, yra draudžiami.

LV • Šis lietotāja rokasgrāmatas saturs un attēli ir veidoti tikai ST. S.p.A. un ir aizsargāti ar autortiesībām. Jebkāda dokumenta vai tā daļas prettiesiska kopēšana vai pārveide ir stingri aizliegta.

MK • Содржината и сликите во Упатството за корисникот се подготвени исклучиво за ST. S.p.A. и се заштитени со авторски права – забрането е секое делумно или целосно неовластено репродуцирање или измена на документот.

NL • De inhoud en de afbeeldingen van deze gebruikshandleiding werden gerealiseerd voor rekening van ST. S.p.A. en zijn beschermd door het auteursrecht – Elke niet-geautoriseerde reproductie of wijziging, ook gedeeltelijke, van het document is verboden.

NO • Innholdet og bildene i denne brukerveiledningen er utført på oppdrag fra ST. S.p.A. og er beskyttet ved opphavsrett – Enhver gjengivelse eller endring, selv kun delvis, er forbudt.

PL • Treść oraz ilustracje zawarte w niniejszej instrukcji obsługi powstały na zlecenie spółki ST. S.p.A. i są chronione prawami autorskimi – Zabrania się wszelkiego kopiowania bądź modyfikowania, także częściowego, niniejszego dokumentu bez uzyskania stosownej zgody.

PT • As imagens e os conteúdos contidos no presente Manual do Utilizador foram expressamente criados para uso exclusivo da ST. S.p.A., encontrando-se protegidos por direitos de autor. Qualquer tipo de reprodução ou alteração, parcial ou integral, não autorizadas deste Manual estão expressamente proibidas.

RO • Conținutul și imaginile din manualul de utilizare de față au fost realizate în numele ST. S.p.A. și sunt protejate de drepturi de autor – Este interzisă orice reproducere sau modificare chiar și parțială neautorizată a documentului.

RU • Тесты и изображения, содержащиеся в настоящем руководстве, были созданы в интересах ST. S.p.A. и защищены авторскими правами – Любое несанкционированное воспроизведение или изменение документа запрещено.

SK • Obsah a obrázky v tomto návode na používanie boli spracované menom spoločnosti ST. S.p.A. a sú chránené autorským právom – Reprodukcie či nepovolené pozměňovanie tohto dokumentu, a to aj čiastočné, je zakázané.

SL • Vsebine in slike v tem uporabniškem priručniku so izdelane za podjetje ST. S.p.A. in so zaščitene z avtorskimi pravicami – vsakršno nepooblaščenno razmnoževanje ali spreminjanje dokumenta, v celoti ali delno, je prepovedano.

SR • Sadržaj i slike ovog priručnika za upotrebu su napravljeni u ime ST. S.p.A. i zaštićeni su autorskim pravima – Zabranjena je svaka potpuna ili delimična reprodukcija ili izmena dokumenta bez odobrenja.

SV • Innehållet och bilderna i denna användarhandbok har framställts för ST. S.p.A. och skyddas av upphovsrätt – all form av reproduktion eller ändring, även partiell, som inte auktoriserats är förbjuden.

TR • Bu Kullanıcı Kilavuzundaki içerik ve resimler açığıca ST. S.p.A. için üretilmiştir ve telif hakkı ile korunmaktadır – dokümanın izinsiz olarak tamamen ya da kısmen herhangi bir şekilde çoğaltılması ya da dağıtılması yasaktır.



.....

Type:

Art.N CE
.....-s/n