

# DAILY REFERENCE GUIDE



## THANK YOU FOR PURCHASING AN HOTPOINT-ARISTON PRODUCT

To receive more comprehensive help and support, please register your product at [www.hotpoint.eu/register](http://www.hotpoint.eu/register)





You can download the Safety Instructions and the Use and Care Guide by visiting our website [docs.hotpoint.eu](http://docs.hotpoint.eu) and following the instructions on the back of this booklet.

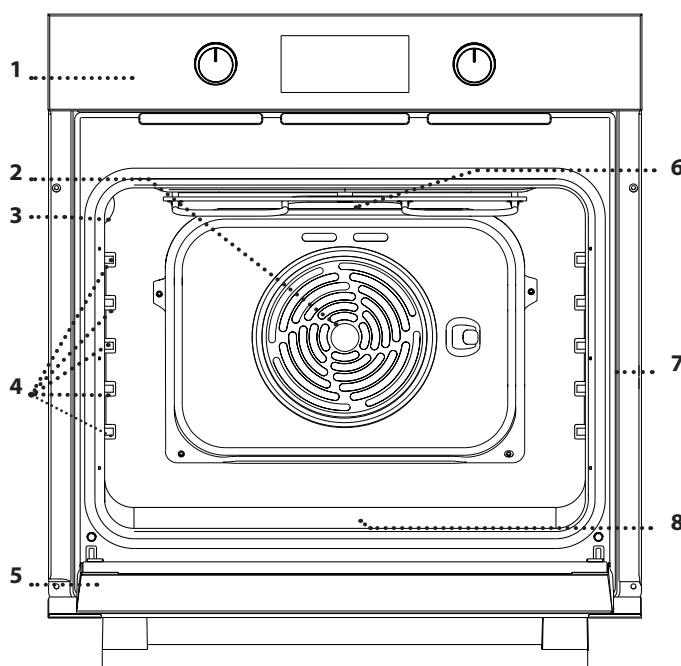

Before using the appliance carefully read the Health and Safety guide.

## PRODUCT DESCRIPTION



1. Control panel
2. Fan
3. Lamp
4. Shelf guides  
(the level is indicated on the wall of the cooking compartment)
5. Door
6. Upper heating element/grill
7. Identification plate  
(do not remove)
8. steam  embossing for drinking water

## CONTROL PANEL DESCRIPTION

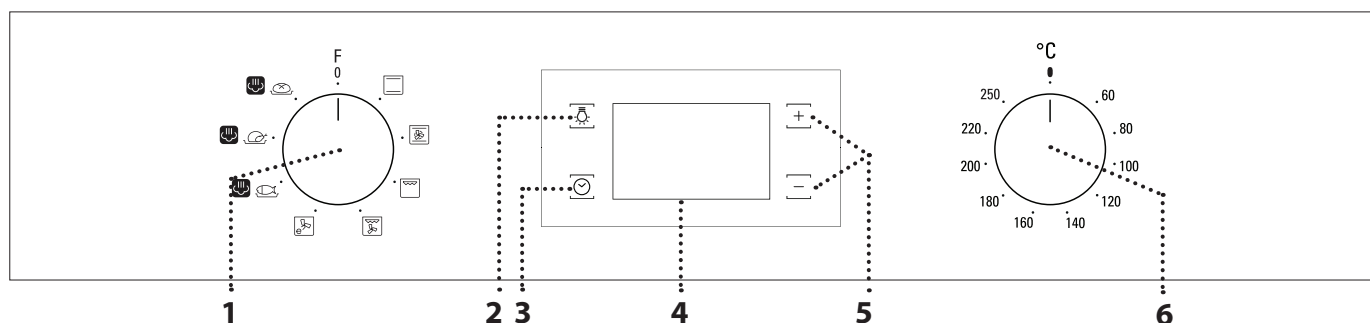

### 1. SELECTION KNOB

For switching the oven on by selecting a function. Turn to the 0 position to switch the oven off.

### 2. LIGHT

With the oven switched on, press  to turn the oven compartment lamp on or off.

### 3. SETTING THE TIME

For accessing the cooking time settings, delayed start and timer. For displaying the time when the oven is off.

### 4. DISPLAY

### 5. ADJUSTMENT BUTTONS

For changing the cooking time settings.

### 6. THERMOSTAT KNOB

Turn to select the temperature you require when activating manual functions.

# Hotpoint

ARISTON

# ACCESSORIES

## WIRE SHELF

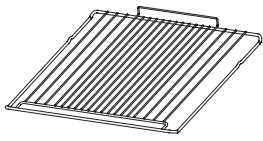

Use to cook food or as a support for pans, cake tins and other ovenproof items of cookware.

## DRIP TRAY \*

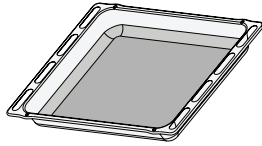

Use as an oven tray for cooking meat, fish, vegetables, focaccia, etc. or position underneath the wire shelf to collect cooking juices.

## BAKING TRAY \*

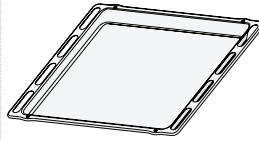

Use for cooking all bread and pastry products, but also for roasts, fish en papillote, etc.

## SLIDING RUNNERS \*

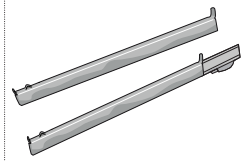

To facilitate inserting or removing accessories.

\* Available only on certain models.

The number and the type of accessories may vary depending on which model is purchased.

Other accessories can be purchased separately from the After-sales Service.

## INSERTING THE WIRE SHELF AND OTHER ACCESSORIES

. Insert the wire shelf onto the level you require by holding it tilted slightly upwards and resting the raised rear side (pointing upwards) down first. Then slide it horizontally along the runners as far as possible.

. Other accessories, like the baking tray, are to be inserted horizontally, letting them slide on the runners.

## REMOVING AND REFITTING THE SHELF GUIDES

. To remove the shelf guides, firmly grip the external part of the guide, and pull it towards you to extract the support and the two internal pins from the lodging.

. To reposition the shelf guides, position them near the cavity and initially insert the two pins into their lodgings. Next, position the external part near its lodging, insert the support, and firmly press towards the wall of the cavity to make sure the shelf guide is properly secured.

## FITTING THE SLIDING RUNNERS (IF PRESENT)

Remove the shelf guides. Disengage the guide's anchoring clips from the shelf guide, starting from the lower part.

To reinstall the sliding guides, anchor the guide's upper clip to the shelf guide, then lower the other clip into position. To secure the guide, press the lower portion of the clip firmly against the shelf guide. Make sure that the runners can move freely. Reposition the shelf guides.

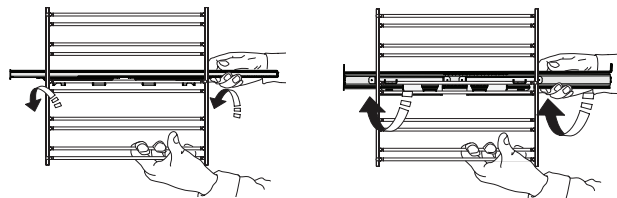



Please note: The sliding runners can be fitted on any level.



## FUNCTIONS

 **CONVENTIONAL**  
For cooking any kind of dish on one shelf only.

 **CONVECTION BAKE**  
To cook on a maximum of two shelves at the same time. It is a good idea to swap the position of the baking trays halfway through cooking.

 **GRILL**  
For grilling steaks, kebabs and sausages, cooking vegetables au gratin or toasting bread. When grilling meat, we recommend using a dripping pan to collect the cooking juices: position the pan on any of the levels below the wire shelf and add 200 ml of drinking water.

 **TURBO GRILL**  
For roasting large joints of meat (legs, roast beef, chicken). We recommend using a dripping pan to collect the cooking juices: position the pan on any of the levels below the wire shelf and add 200 ml of drinking water.

 **ECO FORCED AIR**  
For cooking roasts and stuffed roasting joints on a single shelf. Food is prevented from drying out excessively by gentle, intermittent air circulation. When this ECO function is in use, the light will remain switched off during cooking but can be switched on again by pressing .



steam 

- **FISH** 
- **MEAT** 
- **BREAD** 







The steam  functions provide excellent results thanks to the addition of steam in cooking cycles. Only when the oven is cold, pour drinking water on the bottom of the oven and select the specific function for your preparation. The optimal water quantities and temperatures for each food category are listed in the relative cooking table. **Preheat the oven before inserting food.**

## FIRST TIME USE

### 1. SETTING THE TIME

You will need to set the time when you switch on the appliance for the first time: Press  until the  icon and the two digits for the hour start flashing on the display.



Use  or  to set the hour and press  to confirm. The two digits for the minutes will start flashing. Use  or  to set the minutes and press  to confirm.

Please note: When the  icon is flashing, for example following lengthy power outages, you will need to reset the time.

### 2. HEAT THE OVEN

A new oven may release odours that have been left behind during manufacturing: this is completely normal.

Before starting to cook food, we therefore recommend heating the oven with it empty in order to remove any possible odours.

Remove any protective cardboard or transparent film from the oven and remove any accessories from inside it.

Heat the oven to 250 °C for about one hour. The oven must be empty during this time.

Please note: It is advisable to air the room after using the appliance for the first time.

## DAILY USE

### 1. SELECT A FUNCTION

To select a function, turn the *selection knob* to the symbol for the function you require: the display will light up and an audible signal will sound.



### 2. ACTIVATE A FUNCTION

#### MANUAL

To start the function you have selected, turn the *thermostat knob* to set the temperature you require.



Please note: During cooking you can change the function by turning the selection knob or adjust the temperature by turning the thermostat knob. The function will not start if the thermostat knob will be on . You can set the cooking time, cooking end time (only if you set a cooking time) and a timer.

steam 

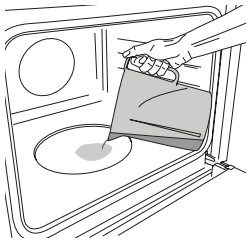



Only when the oven is cold, fill the embossing of the cavity with the quantity of drinking water suggested in the relative cooking table.

Set and activate the steam  function: At the end, carefully open the door and let steam escape slowly.

Please note: During steam cooking, do not open the door and never top up the water.

### 3. PREHEATING

Once the function starts, an audible signal and a flashing icon  on the display indicate that the preheating phase has been activated.



At the end of this phase, an audible signal and the fixed icon  on the display will indicate that the oven has reached the set temperature: at this point, place the food inside and proceed with cooking.

Please note: Placing the food in the oven before preheating has finished may have an adverse effect on the final cooking result.



### PROGRAMMING COOKING

You will need to select a function before you can start programming cooking.



#### DURATION

Keep pressing  until the  icon and "00:00" start flashing on the display.





Use  or  to set the cooking time you require, then press  to confirm.



Activate the function by turning the *thermostat knob* to the temperature you require: an audible signal will sound and the display will indicate that cooking is complete.

Please note: To cancel the cooking time you have set, keep pressing  until the  icon starts flashing on the display, then use  to reset the cooking time to "00:00". This cooking time includes a preheating phase.

### PROGRAMMING THE END COOKING TIME/ DELAYED START

After a cooking time has been set, starting the function can be delayed by programming its end time: press  until the  icon and the current time start flashing on the display.



Use  or  to set the time you want cooking to end and press  to confirm.

Activate the function by turning the *thermostat knob* to the temperature you require: the function will remain paused until it starts automatically after the period of time that has been calculated in order forcooking to finish at the time you have set.

Please note: To cancel the setting, switch the oven off by turning the selection knob to the 0 position.

Please note: Delay to start functionality is not available for Grill and Turbo Grill functions.

### END OF COOKING

An audible signal will sound and the display will indicate that the function has finished.





Turn the *selection knob* to select a different function or to 0 to switch the oven off.



Please note: If the timer is active, the display will show "END" alternately with the remaining time.

### SETTING THE TIMER

This option does not interrupt or program cooking but allows you to use the display as a timer, either during while a function is active or when the oven is off.

Keep pressing  until the  icon and "00:00" icon and "00:00" start flashing on the display.



















































































Use  or  to set the time you require and press  to confirm.

An audible signal will sound once the timer has finished counting down the selected time.

Notes: To cancel the timer, keep pressing  until the  icon starts flashing, then use  to reset the time to "00:00".

# COOKING TABLE

RECIPE	FUNCTION	PREHEAT	TEMPERATURE (°C)	DURATION (Min)	LEVEL AND ACCESSORIES
Leavened cakes		Yes	170	30 - 50	
		Yes	160	30 - 50	
		Yes	160	40 - 60 *	 
Filled cake (cheese cake, strudel, fruit pie)		Yes	160 - 200	35 - 90	
		Yes	160 - 200	35 - 90 *	 
Biscuits / tartlets		Yes	160	25 - 35	
		Yes	160	25 - 35	
		Yes	160	20 - 35 *	 
Choux buns		Yes	180 - 200	30 - 40	
		Yes	180 - 190	35 - 45 *	 
Meringues		Yes	90	150 - 200	
		Yes	90	140 - 200	 
Pizza / Focaccia		Yes	190 - 250	15 - 50	
		Yes	190 - 250	25 - 50 *	 
Frozen pizza		Yes	250	10 - 15	
		Yes	250	10 - 20 *	 
Salty cakes (vegetable pie, quiche)		Yes	175 - 200	45 - 60	
		Yes	175 - 190	45 - 60 *	 
Vols-au-vents / puff pastry crackers		Yes	190 - 200	20 - 30	
		Yes	180 - 190	15 - 40 *	 
Lasagne / baked pasta / cannelloni / flans		Yes	190 - 200	45 - 65	
Lamb / veal / beef / pork 1 kg		Yes	190 - 200	80 - 110	
Roast pork with crackling 2 kg		Yes	180 - 190	110 - 150	
Chicken / rabbit / duck 1 kg		Yes	200 - 230	50 - 100	
Turkey / goose 3 kg		-	190 - 200	100 - 160	
Baked fish / en papillote (fillets, whole)		Yes	170 - 190	30 - 45	
Stuffed vegetables (tomatoes, courgettes, aubergines)		Yes	180 - 200	50 - 70	
Toasted bread		5'	250	2 - 6	
Fish fillets / slices		-	230 - 250	15 - 30 **	 
Sausages / kebabs / spare ribs / hamburgers		-	250	15 - 30 **	 
Roast chicken 1-1,3 kg		Yes	200 - 220	55 - 70 ***	 
Roast beef rare 1 kg		Yes	200 - 210	35 - 50 ***	
Leg of lamb / knuckle		Yes	200 - 210	60 - 90 ***	
Roast potatoes		Yes	200 - 210	35 - 55 ***	

## FUNCTIONS

  
 Conventional

  
 Convection Bake

  
 Grill

  
 Turbo Grill

  
 Eco Forced Air

## ACCESSORIES

  
 Wire shelf

  
 Baking dish or cake tin  
 on the wire shelf

  
 Baking tray/Drip tray or Baking  
 dish on the wire shelf

  
 Drip tray / Baking tray

  
 Drip tray / Baking tray with  
 200 ml of water

RECIPE	FUNCTION	PREHEAT	TEMPERATURE (°C)	DURATION (Min)	LEVEL AND ACCESSORIES
Vegetable gratin		-	200 - 210	25 - 55	3
Meat and potatoes		Yes	190 - 200	45 - 100 ****	4 1
Fish and vegetables		Yes	180	30 - 50 ****	4 2
Lasagne and meat		Yes	200	50 - 100 ****	4 1
Roast meat / stuffed roasting joints		-	170 - 180	100 - 150	2

\* Switch racks halfway through cooking.

\*\* Turn food halfway through cooking.

\*\*\* Turn food two thirds of the way through cooking (if necessary).

\*\*\*\* Estimated length of time: dishes can be removed from the oven at different times depending on personal preference. Switch racks two thirds through cooking if necessary.

steam						
RECIPE	FUNCTION	WATER (ml)	PREHEAT	TEMPERATURE (°C)	DURATION (Min)	LEVEL AND ACCESSORIES
Fish fillets / cutlets 0.5 - 2 cm	steam	250	Yes	190 - 210	10 - 20	3
Whole fish 300 - 600 g	steam	250	Yes	190 - 210	10 - 25	3
Whole fish 600 g - 1.2 kg	steam	250	Yes	180 - 200	20 - 40	3
Roast Beef rare 1 kg	steam	250	Yes	190 - 210	30 - 45	3
Lamb shank 500 g - 1.5 kg	steam	250	Yes	170 - 190	60 - 75	2
Chicken / guinea fowl / duck Whole 1 - 1.5 kg	steam	250	Yes	200 - 220	50 - 70	2
Chicken / guinea fowl / duck Pieces 500 g - 1.5 kg	steam	250	Yes	200 - 220	40 - 60	3
Chicken / turkey / duck Whole 3 kg	steam	250	Yes	160 - 180	100 - 140	2
Lamb / Beef / Pork 1 kg	steam	250	Yes	170 - 190	60 - 90	3
Small bread 80 - 100 g	steam	200	Yes	200 - 220	20 - 30	3
Sandwich loaf in tin 300 - 500 g	steam	250	Yes	170 - 190	35 - 50	3
Bread loaf 500 g - 2 kg	steam	250	Yes	160 - 170	50 - 100	2
Baguettes 200 - 300 g	steam	250	Yes	200 - 220	25 - 40	3

The time indicated does not include the preheating phase: we recommend placing the food in the oven and setting the cooking time only after the required temperature has been reached.

FUNCTIONS						steam	steam	steam
	Conventional	Convection Bake	Grill	Turbo Grill	Eco Forced Air	Fish	Meat	Bread
ACCESSORIES								
	Wire shelf	Baking dish or cake tin on the wire shelf	Baking tray/Drip tray or Baking dish on the wire shelf	Baking tray/Drip tray or Baking dish on the wire shelf	Drip tray / Baking tray	Drip tray / Baking tray	Drip tray / Baking tray with 200 ml of water	Drip tray / Baking tray with 200 ml of water

## CLEANING AND MAINTENANCE

Make sure that the oven has cooled down before carrying out any maintenance or cleaning.  
Do not use steam cleaners.

Do not use wire wool, abrasive scourers or abrasive/corrosive cleaning agents, as these could damage the surfaces of the appliance.

Wear protective gloves.  
The oven must be disconnected from the mains before carrying out any kind of maintenance work.

### EXTERIOR SURFACES

Clean the surfaces with a damp microfibre cloth. If they are very dirty, add a few drops of pH-neutral detergent. Finish off with a dry cloth.

Do not use corrosive or abrasive detergents. If any of these products inadvertently comes into contact with the surfaces of the appliance, clean immediately with a damp microfibre cloth.

### INTERIOR SURFACES

- After every use, leave the oven to cool and then clean it, preferably while it is still warm, to remove any deposits or stains caused by food residues. To dry any condensation that has formed as a result of cooking foods with a high water content, leave the oven to cool completely and then wipe it with a cloth or sponge.

- To remove the remaining limestone from the bottom of the cavity after the steam cooking, just pour 250 ml of white vinegar onto the embossing of the cavity (alternatively, use a specific descaling product. For availability please contact the After Sales Service). Leave it to work at room temperature for 30 minutes, then clean the cavity with warm drinking water and a soft cloth. Cleaning is recommended at least for every 5 to 10 steam cooking cycles.
- The door can be easily removed and refitted to facilitate cleaning of the glass.
- Clean the glass in the door with a suitable liquid detergent.

### ACCESSORIES

Soak the accessories in a washing-up liquid solution after use, handling them with oven gloves if they are still hot. Food residues can be removed using a washing-up brush or a sponge.

### REMOVING AND REFITTING THE DOOR

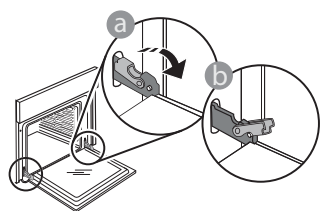

1. To remove the door, open it fully and lower the catches until they are in the unlock position.

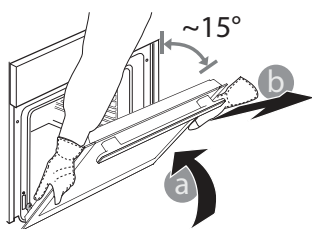

2. Close the door as much as you can. Take a firm hold of the door with both hands – do not hold it by the handle. Simply remove the door by continuing to close it while pulling it upwards at the same time

until it is released from its seating. Put the door to one side, resting it on a soft surface.

3. Refit the door by moving it towards the oven, aligning the hooks of the hinges with their seating and securing the upper part onto its seating.

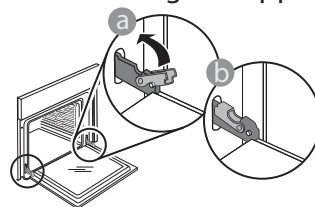

4. Lower the door and then open it fully. Lower the catches into their original position: Make sure that you lower them down completely.

Apply gentle pressure to check that the catches are in the correct position.

5. Try closing the door and check to make sure that it lines up with the control panel. If it does not, repeat the steps above: The door could become damaged if it does not work properly.

### REPLACING THE LAMP

1. Disconnect the oven from the power supply.
2. Unscrew the cover from the light, replace the bulb and screw the cover back on the light.
3. Reconnect the oven to the power supply.

Please note: Use 25 W/230 V type G9, T300 °C halogen lamps.

The bulb used in the product is specifically designed for domestic appliances and is not suitable for general room lighting within the home (EC Regulation 244/2009).

Light bulbs are available from our After-sales Service. - Do not handle bulbs with your bare hands as your fingerprints could damage them. Do not use the oven until the light cover has been refitted.

## CLICK & CLEAN - CLEANING THE GLASSES

1. After removing the door and resting it on a soft surface with the handle downwards, simultaneously press the two retaining clips and remove the upper edge of the door by pulling it towards you.

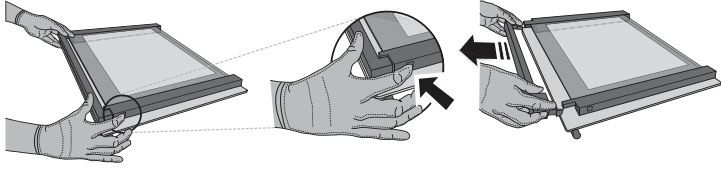

2. Lift and firmly hold the inner glass with both hands, remove it and place it on a soft surface before cleaning it.

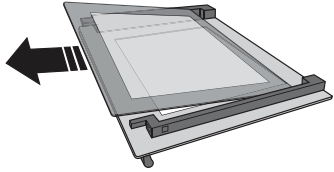

3. Refit the intermediate pane (marked with "R") before refitting the inside pane: To position the panes of glass correctly, make sure that the "R" mark can be seen in the left-hand corner. First insert the long side of the glass marked "R" into the support seats, then lower it into position. Repeat this procedure for both panes of glass.

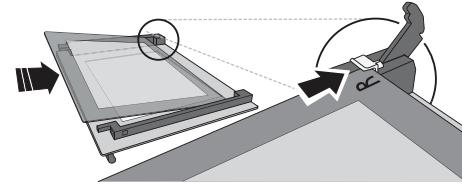

4. Refit the upper edge: A click will indicate correct positioning. Make sure the seal is secure before refitting the door.

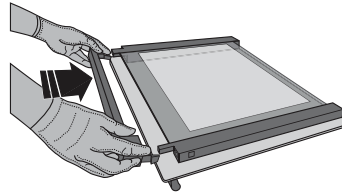

## TROUBLESHOOTING

PROBLEM	POSSIBLE CAUSE	SOLUTION
The oven is not working.	Power cut. Disconnection from the mains.	Check for the presence of mains electrical power and whether the oven is connected to the electricity supply. Turn off the oven and restart it to see if the fault persists.
The display shows the letter "F" followed by a number or letter.	Oven failure.	Contact your nearest Client After-sales Service Centre and state the number following the letter "F".

## PRODUCT FICHE

 [www](http://www.docs.hotpoint.eu) The product fiche with energy data of this appliance can be downloaded from the website **docs.hotpoint.eu**

## HOW TO OBTAIN THE USE AND CARE GUIDE

>  [www](http://www.docs.hotpoint.eu) Download the Use and Care Guide from our website **docs.hotpoint.eu** (you can use this QR Code), specifying the product's commercial code.



> Alternatively, contact our Client After-sales Service.

## CONTACTING OUR AFTER-SALES SERVICE

You can find our contact details in the warranty manual. When contacting our Client After-sales Service, please state the codes provided on your product's identification plate.

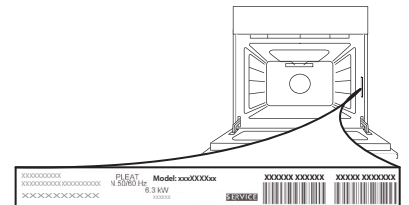



# GUIDE D'UTILISATION QUOTIDIENNE

## MERCI D'AVOIR CHOISI UN PRODUIT HOTPOINT-ARISTON



Afin de recevoir un service et un support complet, merci d'enregistrer votre appareil sur [www.hotpoint.eu/register](http://www.hotpoint.eu/register)



Vous pouvez télécharger les Consignes de sécurité et le Guide d'utilisation et entretien en visitant notre site Web [docs.hotpoint.eu](http://docs.hotpoint.eu) et en suivant les consignes au dos de ce livret.



Lire attentivement les Consignes de santé et de sécurité avant d'utiliser l'appareil.

## DESCRIPTION DU PRODUIT

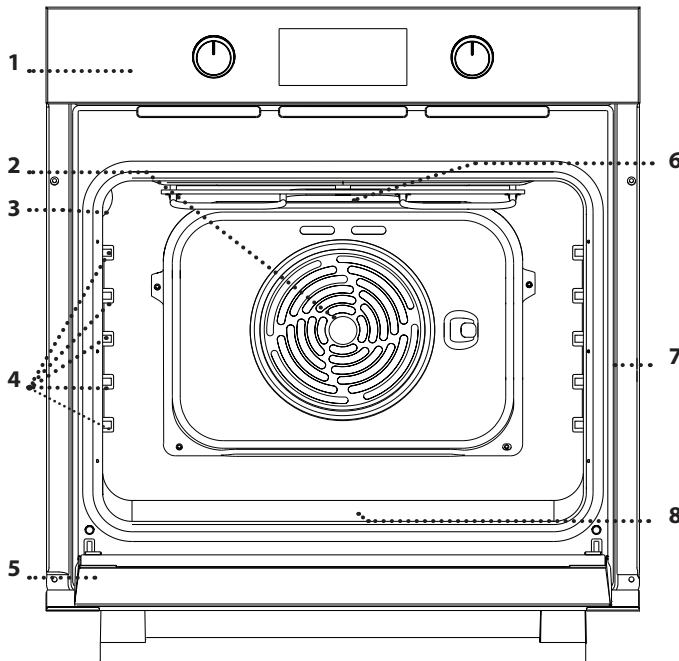

1. Bandeau de commande
2. Ventilateur
3. Ampoule
4. Supports de grille  
(le niveau est indiqué sur la paroi du compartiment de cuisson)
5. Porte
6. Élément chauffant supérieur/grill
7. Plaque signalétique  
(ne pas enlever)
8. steam gaufrage pour eau potable

## DESCRIPTION DU BANDEAU DE COMMANDE

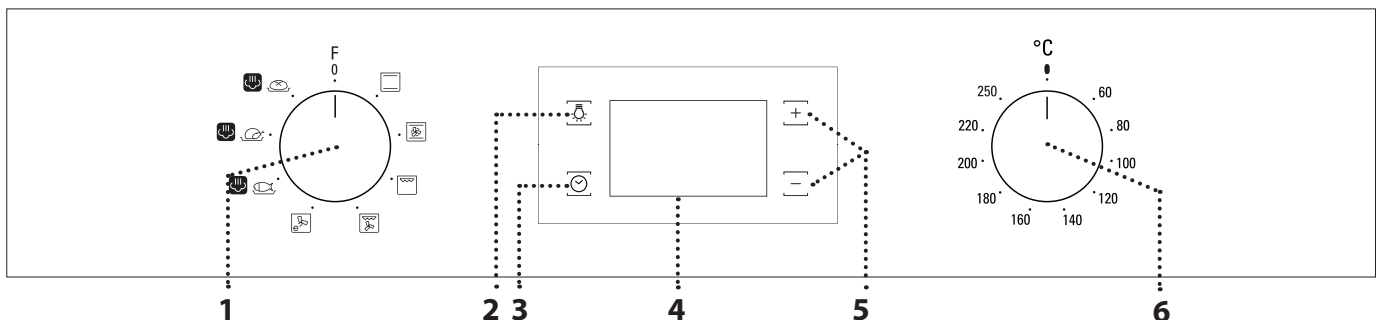

### 1. BOUTON DE SÉLECTION

Pour allumer le four en sélectionnant une fonction. Tournez dans la position 0 pour éteindre le four.

### 2. LAMPE

Avec le four allumé, appuyez sur pour allumer ou éteindre l'ampoule du compartiment du four.

### 3. RÉGLAGE DE L'HEURE

Pour accéder les réglages pour le temps de cuisson, le départ différé, et la minuterie.

Pour afficher l'heure lorsque le four est éteint.

### 4. ÉCRAN

### 5. BOUTONS DE RÉGLAGES

Pour changer les réglages du temps de cuisson.

### 6. BOUTON THERMOSTAT

Tournez pour sélectionner la température désirée lorsque vous utilisez les fonctions manuelles.

# Hotpoint

ARISTON

# ACCESSOIRES

## GRILLE MÉTALLIQUE

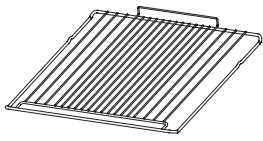

Utilisées pour la cuisson des aliments ou comme support pour les lèchefrites, moules à gâteau, et autres plats de cuisson résistants à la chaleur.

## LÈCHEFRITE\*

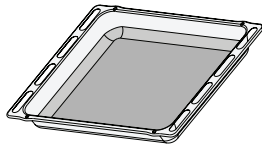

Utiliser comme plat de cuisson pour la viande, le poisson, les légumes, la focaccia, etc., ou pour recueillir les jus de cuisson en la plaçant sous la grille métallique.

## PLAQUE À PÂTISSERIE \*

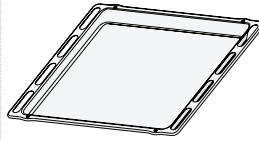

Pour la cuisson du pain et des pâtisseries, mais aussi pour cuire des rôtis, du poisson en papillotes, etc.

## GRILLES COULISSANTES \*

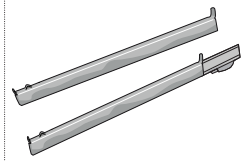

Pour insérer ou enlever les accessoires plus facilement.

\* Disponible sur certains modèles seulement.

Le nombre et type d'accessoires peuvent varier selon le modèle acheté.

Il est possible d'acheter séparément d'autres accessoires auprès du Service Après-Vente.

## INSÉRER LA GRILLE MÉTALLIQUE ET LES AUTRES ACCESSOIRES

. Insérez la grille métallique au niveau désiré en la tenant légèrement inclinée vers le haut et en déposant la partie surélevée arrière (pointant vers le haut) en premier.

Glissez-la ensuite horizontalement sur les glissières aussi loin que possible.

. Les autres accessoires, comme la plaque de cuisson, sont insérés horizontalement en les laissant glisser sur les glissières.

## ENLEVER ET REPLACER LES SUPPORTS DE GRILLE

. Pour enlever les supports de grille, agrippez fermement la partie externe du support et tirez-le vers vous pour sortir le support et les deux goupilles internes de leur appui.

. Pour replacer les supports de grille, placez-les près de la cavité et insérez en premier les deux goupilles dans leur appui. Ensuite, placez la partie externe près de son appui, insérez le support, et appuyez fermement vers la paroi pour s'assurer que le support est bien inséré.

## INSTALLER LES GRILLES COULISSANTES (SELON LE MODÈLE)

Enlevez les supports de grille. Dégagez les agrafes d'ancrages du support de grille, en commençant avec la partie inférieure.

Pour installer de nouveau les supports de grille, ancrer l'agrafe supérieure du support en place, abaissez ensuite l'autre agrafe en place. Pour fixer le guide, pressez la partie inférieure de l'agrafe fermement sur le support de grille. Assurez-vous que les grilles peuvent se déplacer librement. Remplacez les supports de grille.

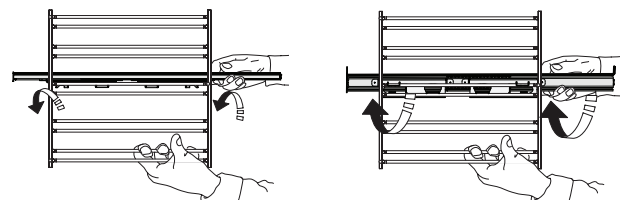

Veillez noter : Les grilles coulissantes peuvent être installées au niveau de votre choix.

## FONCTIONS



### CONVECTION NATURELLE

Pour cuire tout type de plat sur une seule grille.



### CONVECTION FORCÉE

Pour cuire sur un maximum de deux niveaux en même temps. Nous vous conseillons d'échanger la position des plaques de cuisson à la mi-cuisson.



### GRIL

Pour cuire des biftecks, des brochettes, et des saucisses, faire gratiner des légumes et griller du pain.

Pour la cuisson de la viande, nous vous conseillons d'utiliser une lèchefrite pour recueillir les jus de cuisson : placez la lèchefrite, contenant 200 ml d'eau, sur un quelconque niveau sous la grille.



### TURBO GRIL

Pour griller de gros morceaux de viande (gigots, rôti de bœuf, poulets). Nous vous conseillons d'utiliser une lèchefrite pour recueillir les jus de cuisson : placez la lèchefrite, contenant 200 ml d'eau, sur un quelconque niveau sous la grille.



### ÉCO CHALEUR PULSÉE

Pour cuire les rôtis farcis et les rôtis sur une seule grille. Les aliments ne s'assèchent pas trop grâce à une légère circulation d'air intermittente. Lorsque vous utilisez la fonction ÉCO, le voyant reste éteint durant la cuisson, mais peut être rallumé temporairement en appuyant sur .

steam

- POISSON
- VIANDES
- PAIN

Les fonctions steam donnent d'excellents résultats grâce à l'ajout de vapeur dans les cycles de cuisson. Placez de l'eau potable au fond de la cavité et sélectionnez la fonction spécifique pour votre préparation, uniquement lorsque le four est froid. Les quantités et températures optimales de l'eau pour chaque catégorie d'aliments sont énumérées dans le tableau de cuisson correspondant. **Préchauffez le four avant d'y introduire les aliments.**

## PREMIÈRE UTILISATION

### 1. RÉGLAGE DE L'HEURE

Vous devez régler l'heure lorsque vous allumez l'appareil pour la première fois : Appuyez sur jusqu'à ce que le voyant et les deux chiffres indiquant l'heure clignotent à l'écran.



Utilisez ou pour régler l'heure et appuyez sur pour confirmer. Les deux chiffres des minutes clignotent. Utilisez ou pour régler les minutes et appuyez sur pour confirmer.

Veillez noter: Lorsque le voyant clignote (par exemple après des pannes de courant prolongées), vous devrez régler l'heure de nouveau.

## UTILISATION QUOTIDIENNE

### 1. SÉLECTIONNER UNE FONCTION

Pour sélectionner une fonction, tournez le *bouton de sélection* sur le symbole de la fonction désirée : l'écran s'illumine et un signal sonore se fait entendre.



### 2. ACTIVER UNE FONCTION

#### MANUEL

Pour lancer la fonction que vous avez sélectionnée, tournez le *bouton du thermostat* pour régler la température requise.

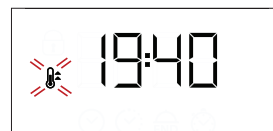

Veillez noter : Lors de la cuisson, vous pouvez changer la fonction en tournant le bouton de sélection ou ajuster la température en tournant le bouton du thermostat. La fonction ne démarre pas tant que le bouton du thermostat est sur . Vous pouvez régler le temps de cuisson, le temps de fin de cuisson (seulement si vous réglez le temps de cuisson) et la minuterie.

steam 

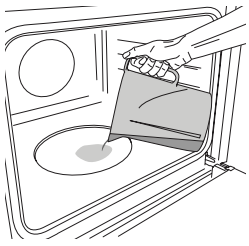



Une fois que le four est froid seulement, remplissez le gaufmage de la cavité avec la quantité d'eau potable suggérée dans le tableau de cuisson correspondant.

Réglez et activez la fonction steam  :  
À la fin, ouvrez la porte avec précaution et laissez la vapeur s'échapper lentement.

Veillez noter : Pendant la cuisson à la vapeur, n'ouvrez pas le four et ne rajoutez jamais d'eau.

### 3. PRÉCHAUFFAGE

Une fois que la fonction est lancée, un signal sonore et un voyant  qui clignote à l'écran confirmant que la phase de préchauffage est activée.

À la fin de cette phase, un signal sonore et un voyant stable  indique que le four a atteint la température désirée : vous pouvez maintenant placer les aliments à l'intérieur et débiter la cuisson.

Veillez noter: Placer les aliments dans le four avant la fin du préchauffage peut affecter la qualité de la cuisson.

### PROGRAMMER LA CUISSON

Vous devez sélectionner une fonction avant de pouvoir lancer un programme de cuisson.



#### DURÉE

Appuyez sur la touche  jusqu'à ce que le voyant  et « 00:00 » clignotent à l'écran.





Utilisez  ou  pour régler la durée de cuisson et appuyez sur  pour confirmer.

Lancez la fonction en tournant le *bouton du thermostat* à la température désirée : un signal sonore se fait entendre et l'écran s'illumine lorsque la cuisson est terminée.



Veillez noter : Pour annuler le temps de cuisson, appuyez sur  jusqu'à ce le voyant  clignote sur l'écran, utilisez ensuite  pour remettre le temps de cuisson à « 00:00 ».

» Ce temps de cuisson inclut la phase de préchauffage.

### PROGRAMMER L'HEURE DE FIN DE CUISSON/ DÉPART DIFFÉRÉ

Après avoir réglé le temps de cuisson, vous pouvez retarder le début de la fonction en programmant le temps de fin de cuisson : appuyez sur  jusqu'à ce que l'icône  et l'heure actuelle clignotent à l'écran.



Utilisez  ou  pour régler l'heure de fin de cuisson et appuyez sur  pour confirmer.

Lancez la fonction en tournant le *bouton du thermostat* à la température désirée : la fonction reste en veille et démarre automatiquement après la période d'attente calculée pour que la cuisson se termine à l'heure désirée.

Veillez noter: Pour annuler le réglage, éteindre le four en tournant le bouton de sélection à la position « 0 ».

Veillez noter: Le démarrage différé de la fonctionnalité n'est pas disponible pour les fonctions Grill et Turbo-grill.

### FIN DE CUISSON

Un signal sonore se fait entendre et l'écran s'illumine pour indiquer que la fonction est terminée.





Tournez le *bouton de sélection* pour sélectionner une différente fonction ou placez-le dans la position 0 pour éteindre le four.



Veillez noter: Si la minuterie fonctionne, l'écran affiche « END » en alternance avec le temps restant.

### RÉGLER LA MINUTERIE



Cette option n'interrompt pas ou ne programme pas la cuisson, mais permet d'utiliser l'écran comme minuterie, durant le fonctionnement d'une fonction ou quand le four est éteint.

Maintenez la touche  appuyée jusqu'à ce que l'icône  et "00:00" et "00:00" commence à clignoter sur l'écran.

















































































Utilisez  ou  pour régler l'heure désirée et appuyez sur  pour confirmer.

Un signal sonore se fait entendre lorsque la minuterie a terminé le compte à rebours.

Remarques : Pour annuler la minuterie, appuyez sur  jusqu'à ce que le voyant  clignote, utilisez ensuite  pour remettre le temps à « 00:00 ».

# TABLEAU DE CUISSON

RECETTE	FONCTION	PRÉCHAUF-FER	TEMPÉRATURE (°C)	DURÉE (MIN)	NIVEAU ET ACCESSOIRES
Gâteaux à pâte levée		Oui	170	30 - 50	
		Oui	160	30 - 50	
		Oui	160	40 - 60 *	 
Gâteau fourré (gâteau au fromage, strudel, tarte aux fruits)		Oui	160 - 200	35 - 90	
		Oui	160 - 200	35 - 90 *	 
Biscuits/Tartelettes		Oui	160	25 - 35	
		Oui	160	25 - 35	
		Oui	160	20 - 35 *	 
Chouquettes		Oui	180 - 200	30 - 40	
		Oui	180 - 190	35 - 45 *	 
Meringues		Oui	90	150 - 200	
		Oui	90	140 - 200	 
Pizza/Focaccia		Oui	190 - 250	15 - 50	
		Oui	190 - 250	25 - 50 *	 
Pizza surgelée		Oui	250	10 - 15	
		Oui	250	10 - 20 *	 
Quiches et tartes salés (tarte aux légumes, quiche)		Oui	175 - 200	45 - 60	
		Oui	175 - 190	45 - 60 *	 
Vol-au-vent/biscuits à pâte feuilletée		Oui	190 - 200	20 - 30	
		Oui	180 - 190	15 - 40 *	 
Lasagnes / pâtes au four / cannellonis / tartes		Oui	190 - 200	45 - 65	
Agneau / Veau / Bœuf / Porc 1 kg		Oui	190 - 200	80 - 110	
Rôti de porc avec grattons 2 kg		Oui	180 - 190	110 - 150	
Poulet/lapin/canard 1 kg		Oui	200 - 230	50 - 100	
Dinde / Oie 3 kg		-	190 - 200	100 - 160	
Poisson au four / en papillote (filet, entier)		Oui	170 - 190	30 - 45	
Légumes farcis (tomates, courgettes, aubergines)		Oui	180 - 200	50 - 70	
Pain grillé		5'	250	2 - 6	
Filets/tranches de poisson		-	230 - 250	15 - 30 **	 
Saucisses/brochettes/ côtes levées/hamburgers		-	250	15 - 30 **	 
Poulet rôti 1 - 1,3 kg		Oui	200 - 220	55 - 70 ***	 
Rôti de bœuf saignant 1 kg		Oui	200 - 210	35 - 50 ***	
Gigot d'agneau/jarret		Oui	200 - 210	60 - 90 ***	

## FONCTIONS

  
Convection naturelle



  
Convection forcée

Grill



  
Turbo Grill

  
Éco Chaleur pulsée

## ACCESSOIRES

  
Grille métallique

  
Plaque de cuisson ou moule à  
gâteau sur la grille métallique

  
Plaque de cuisson/lèche-frite  
ou plat de cuisson sur grille  
métallique

  
Lèche-frite / Plaque de cuisson

  
Lèche-frite / Plaque de cuisson  
avec 200 ml d'eau

# Hotpoint

ARISTON

RECETTE	FONCTION	PRÉCHAUF-FER	TEMPÉRATURE (°C)	DURÉE (MIN)	NIVEAU ET ACCESSOIRES
Pommes de terre rôties		Oui	200 - 210	35 - 55 ***	3
Gratin de légumes		-	200 - 210	25 - 55	3
Viandes et pommes de terre		Oui	190 - 200	45 - 100 ****	4 1
Poisson et légumes		Oui	180	30 - 50 ****	4 2
Lasagnes & viande		Oui	200	50 - 100 ****	4 1
Rôtis/rôtis farcis		-	170 - 180	100 - 150	2

\* Changez les niveaux à mi-cuisson.

\*\* Tourner les aliments à mi-cuisson.

\*\*\* Au besoin, retournez les aliments aux deux tiers de la cuisson.

\*\*\*\* Temps approximatif : les plats peuvent être retirés du four en tout temps, selon vos préférences personnelles. Inversez les niveaux aux deux tiers de la cuisson si nécessaire.

steam						
RECETTE	FONCTION	EAU (ml)	PRÉCHAUF-FAGE	TEMPÉRATURE (°C)	DURÉE (Min)	NIVEAU ET ACCESSOIRES
Filets de poisson / côtelettes 0,5 - 2 cm	steam	250	Oui	190 - 210	10 - 20	3
Poisson entier 300 - 600 g	steam	250	Oui	190 - 210	10 - 25	3
Poisson entier 600 g - 1,2 kg	steam	250	Oui	180 - 200	20 - 40	3
Rosbif saignant 1 kg	steam	250	Oui	190 - 210	30 - 45	3
Jarret d'agneau 500 g - 1,5 kg	steam	250	Oui	170 - 190	60 - 75	2
Poulet / pintade / canard Entier 1 - 1,5 kg	steam	250	Oui	200 - 220	50 - 70	2
Poulet / pintade / canard Morceaux 500 g - 1,5 kg	steam	250	Oui	200 - 220	40 - 60	3
Poulet / dinde / canard Entier 3 kg	steam	250	Oui	160 - 180	100 - 140	2
Agneau / Bœuf / Porc 1 kg	steam	250	Oui	170 - 190	60 - 90	3
Petit pain 80 - 100 g	steam	200	Oui	200 - 220	20 - 30	3
Pain à sandwich en moule 300 - 500 g	steam	250	Oui	170 - 190	35 - 50	3
Pain 500 g - 2 kg	steam	250	Oui	160 - 170	50 - 100	2
Baguettes 200 - 300 g	steam	250	Oui	200 - 220	25 - 40	3

La durée de cuisson ne comprend pas la phase de préchauffage : nous vous conseillons de placer les aliments dans le four et régler le temps de cuisson seulement après avoir atteint la température désirée.

FONCTIONS						steam	steam	steam
	Convection naturelle	Convection forcée	Gril	Turbo Gril	Éco Chaleur pulsée	Poisson	Viandes	Pain
ACCESSOIRES								
	Grille métallique	Plaque de cuisson ou gâteau sur la grille métallique	Plaque de cuisson/lèche-frite ou plat de cuisson sur grille métallique	Plaque de cuisson/lèche-frite	Lèche-frite / Plaque de cuisson	Lèche-frite / Plaque de cuisson avec 200 ml d'eau	Lèche-frite / Plaque de cuisson	Lèche-frite / Plaque de cuisson avec 200 ml d'eau

## NETTOYAGE ET ENTRETIEN

Assurez-vous que le four ait refroidi avant tout entretien ou nettoyage.

N'utilisez pas de nettoyeur à vapeur.

N'utilisez pas de laine d'acier, de tampons à récurer abrasifs, ou des détergents abrasifs ou corrosifs, ils pourraient endommager les surfaces de l'appareil.

Utilisez des gants de protection. L'appareil doit être débranché de l'alimentation principale avant d'effectuer des travaux d'entretien.

### SURFACES EXTÉRIEURES

Nettoyez les surfaces à l'aide d'un chiffon en microfibres humide. Si elles sont très sales, ajoutez quelques gouttes de détergent à pH neutre. Essuyez avec un chiffon sec.

N'utilisez pas de détergents corrosifs ou abrasifs. Si l'un de ces produits entre en contact avec des surfaces de l'appareil, nettoyez immédiatement à l'aide d'un chiffon en microfibre humide.

### SURFACES INTÉRIEURES

- Après chaque utilisation, laissez le four refroidir et nettoyez-le, de préférence lorsqu'il est encore tiède, pour enlever les dépôts ou taches laissés par les résidus de nourriture. Pour enlever la condensation qui se serait formée lors de la cuisson d'aliments avec une forte teneur en eau, laissez le four refroidir complètement et essuyez-le avec un chiffon ou une éponge.

- Pour enlever le calcaire résiduel du fond de la cavité après la steam-cuisson, il suffit de verser 250 ml de vinaigre blanc sur le gaufrage de la cavité (en variante, utilisez un produit de détartrage spécifique. Pour connaître la disponibilité, contactez le Service après-vente). Laissez-le fonctionner à la température ambiante pendant 30 minutes, puis nettoyez la cavité avec de l'eau potable tiède et un chiffon doux. Le nettoyage est recommandé au moins tous les 5 à 10 cycles de cuisson.
- La porte peut facilement être enlevée et remplacée pour faciliter le nettoyage de la vitre.
- Nettoyez le verre dans la porte avec un détergent liquide approprié.

### ACCESSOIRES

Faire tremper les accessoires dans de l'eau contenant un détergent à vaisselle après les avoir utilisés ; utilisez des gants de cuisine s'ils sont encore chauds. Utilisez une brosse à vaisselle ou une éponge pour enlever les résidus d'aliments.

### ENLEVER ET RÉINSTALLER LA PORTE

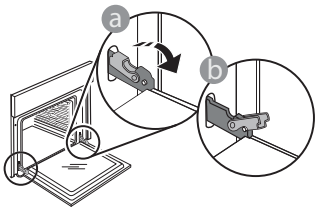

- Pour enlever la porte, ouvrez-la complètement et abaissez les loquets jusqu'à ce qu'ils soient déverrouillés.

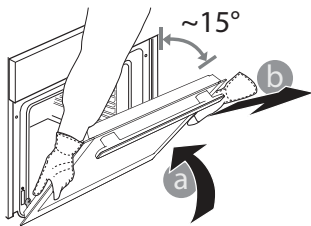

- Fermez le plus possible la porte. Tenez la porte fermement avec les deux mains – ne la tenez pas par la poignée. Enlevez simplement la porte en continuant à la fermer tout en la tirant vers le haut jusqu'à ce qu'elle soit dégagée de ses appuis. Placez la porte de côté,

l'appuyant sur une surface souple.

- Réinstallez la porte en la plaçant devant le four pour aligner les crochets des charnières avec leurs appuis et attacher la partie supérieure sur son appui.

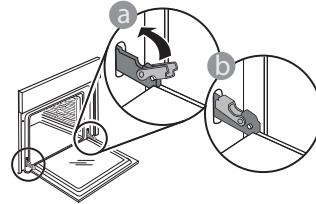

- Abaissez la porte pour ensuite l'ouvrir complètement. Abaissez les loquets dans leur position originale : Assurez-vous de les abaisser complètement.

Appliquez une légère pression pour vous assurer que les loquets sont bien placés.

- Essayez de fermer la porte et assurez-vous qu'elle est alignée avec le panneau de commande. Sinon, répétez les étapes précédentes : La porte pourrait s'endommager si elle ne fonctionne pas correctement.

### REMPACEMENT DE L'AMPOULE

- Débranchez le four de l'alimentation électrique.
- Dévissez le couvercle de l'ampoule, remplacez l'ampoule, et revissez le couvercle.
- Rebranchez le four à l'alimentation électrique.

Veillez noter : Utilisez des ampoules à halogène de 25 W/230 V type G9, T300 °C.

L'ampoule utilisée dans l'appareil est spécialement conçue pour les appareils électroménagers et ne convient pas pour l'éclairage d'une pièce de la maison (Règlement CE 244/2009). Ces ampoules sont disponibles auprès de notre Service Après-vente. Ne manipulez pas les ampoules à mains nues, les traces laissées par vos empreintes pourraient les endommager. Avant d'utiliser le four, assurez-vous que le couvercle de l'ampoule a bien été remis en place.

## CLICK & CLEAN - NETTOYER LES VITRES

1. Après avoir enlevé la porte et l'avoir placée sur une surface matelassée, les poignées vers le bas, appuyez sur les deux fermetures en même temps et enlevez le bord supérieur de la porte en la tirant vers vous.

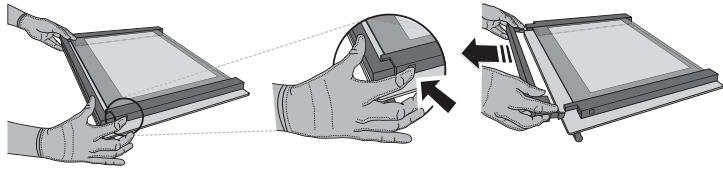

2. Soulevez et tenez fermement la vitre intérieure avec les deux mains, enlevez-la et placez-la sur une surface matelassée avant de la nettoyer.

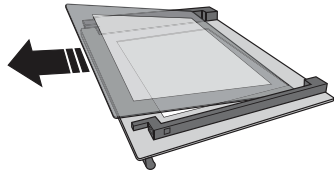

3. Remontez la vitre intermédiaire (marquée « R ») avant de replacer la vitre intérieure : Pour placer correctement les parois de verre, assurez-vous que la marque « R » se trouve dans le coin gauche. En premier, insérez la longue partie de la vitre marquée d'un « R » dans les appuis des guides, abaissez-la ensuite en place. Répétez cette procédure pour les deux parois de verre.

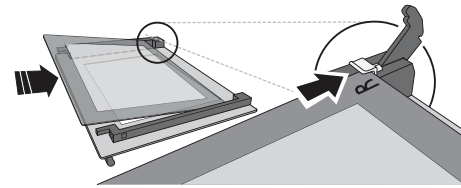

4. Remontez le bord supérieur : un cliquet indique qu'elle est bien placée. Assurez-vous que le joint est bien placé avant de replacer la porte.

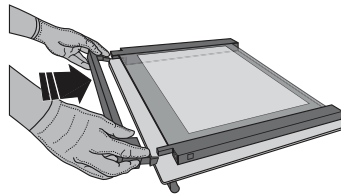

## GUIDE DE DÉPANNAGE

PROBLÈME	CAUSE POSSIBLE	SOLUTION
Le four ne fonctionne pas.	Coupure de courant. Débranchez de l'alimentation principale.	Assurez-vous qu'il n'y a pas de panne de courant et que le four est bien branché. Éteignez puis rallumez le four pour voir si le problème persiste.
L'écran affiche la lettre « F » suivi d'un numéro ou d'une lettre.	Défaillance du four.	Prenez en note le numéro qui suit la lettre « F » et contactez le Service Après-vente le plus près.

## FICHE TECHNIQUE

 La fiche technique, incluant les taux d'efficacité énergétique du four, peut être téléchargée sur notre site Web [docs.hotpoint.eu](http://docs.hotpoint.eu)

## COMMENT OBTENIR LE GUIDE D'UTILISATION ET ENTRETIEN

>  Téléchargez le Guide d'utilisation et d'entretien sur notre site Web [docs.hotpoint.eu](http://docs.hotpoint.eu) (vous pouvez utiliser ce code QR), en précisant le code commercial du produit.



> Une autre façon est de contacter notre Service Après-vente.

## CONTACTER LE SERVICE APRÈS-VENTE

Vous pouvez trouver les informations pour nous contacter dans le livret de garantie. Lorsque vous contactez notre Service Après-vente, veuillez indiquer les codes disponibles sur la plaque signalétique de l'appareil.

