

# 5L300C ROG CHARIOT INSTALLATION GUIDE



Q16330  
First Edition V1.0  
March 2020

## Contents

English.....	3
简体中文.....	16
繁體中文.....	29
Français.....	42
Deutsch.....	55
Italiano.....	68
Русский.....	81
العربية.....	94
Čeština.....	107
עברית.....	120
Magyar.....	133
한국어.....	146
Bahasa Melayu.....	159
Norsk.....	172
Português.....	185
Polski.....	198
Română.....	211
Español.....	224
Slovensky.....	237
Türkçe.....	250
ไทย.....	263

## Safety Notices



- Sit in the center of the chair with your back against the backrest.



- Do not sit on the edge of the chair.



- Do not stand on the chair.



- Do not push down on the reclined backrest when a person is on it.



- Keep your hands and fingers away from the recline mechanism.

## WARNING!

1. This chair should only be used in a normal and non-abusive manner. We are not liable for any damages resulting from improper assembly and/or usage.
2. The maximum recommended weight load is 120KG (264.5 pounds).
3. Never assemble or disassemble your chair in an improper manner.
4. Please keep your chair out of direct sunlight to protect its leather.
5. Please watch your back when the backrest returns back to its original position from a reclined position.
6. To avoid damage to your chair, please do not use excessive force to pull up your headrest.
7. Never try to open and touch the LED module as this will void the warranty.
8. The power input rating for this product is 5V/1A. Do not use a power adapter with an output exceeding 5V/3A.

## A Package Contents

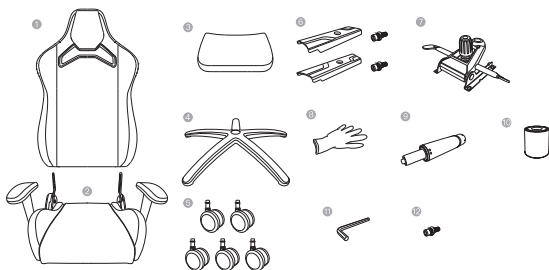

1.	Backrest	5.	Wheels	9.	Hydraulic lift cylinder
2.	Seat base	6.	Side covers with bolts	10.	Telescoping cover
3.	Lumbar cushion	7.	Control unit	11.	Hex Key
4.	Wheel base	8.	Gloves	12.	Spare bolt

**Note:** The illustrations are for reference only and may differ from your actual chair in appearance and features.

## **B** Assembling your chair

Put on the gloves before installation.

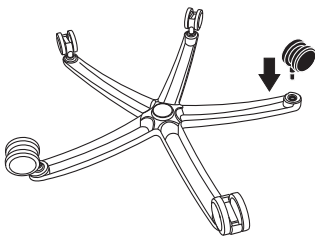

- 1 One by one, insert and push the wheels into the base.

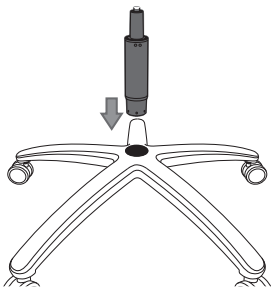

- 2 Insert the hydraulic lift cylinder into the center hole of the base. Remove the red protective cap on top if there was any.

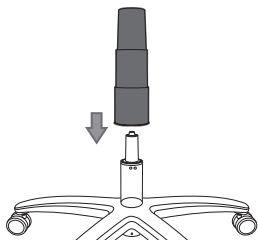

- 3 Place the telescoping cover on the top of the hydraulic lift cylinder.

Armrests normally do not distinguish sides unless labeled otherwise.

For models with armrest pre-assembled, please skip this step.

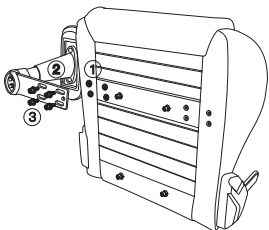

- 4 Remove the pre-assembled bolts and washers (1 & 3). Place the 4 large washers (1) between the armrest mounting bar (2) and the seat base. Hold the armrest in place, then insert and tighten all 4 bolts (3). Use the hex key to tighten them all, and repeat on the other side.

- 5 Use the hex key to remove the pre-assembled bolts and washers from the backrest.

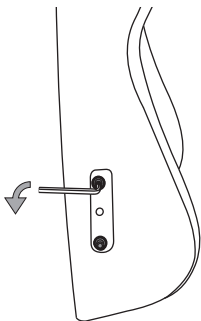

- 6 Remove the protective foam covers from the brackets of the seat base. Then position the backrest carefully between the brackets. Insert and attach the 4 bolts (2 on each side) you removed in step 5 by hand first. Then use the hex key to tighten them. Start with the two bolts on the top of each side, then the bottom two.

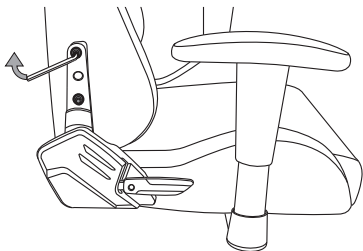

- 7 Install the side covers and tighten the bolts. (The covers are marked "L" for the left side and "R" for the right on the inside.)

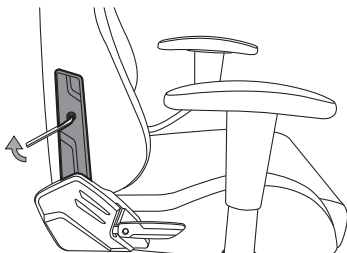

- 8 Now flip the chair over, facing down. Then remove the 4 pre-mounted bolts from the underside with washers.

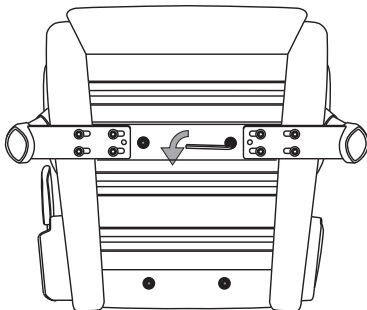

- 9 Repeat the step above to install the control unit, and then place the nut to mount the hydraulic lift cylinder facing the back of the seat (where the backrest is installed).

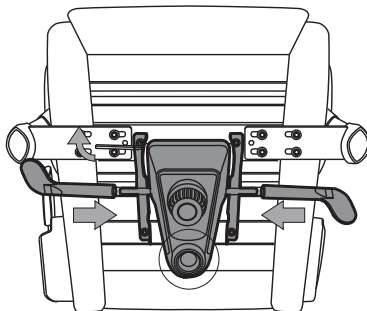

- 10 Insert top of the hydraulic lift cylinder into the mounting hole on the control unit, and then turn the chair over in upright position. (Two-person handling required for your safety).

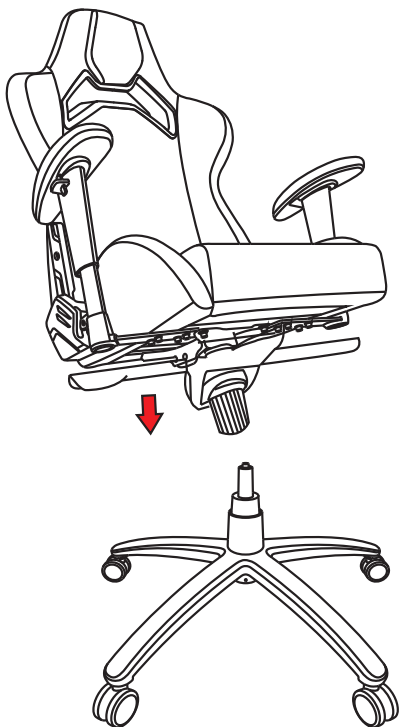



## **C** Lighting up your chair

1. Place your power bank into the packet at the back of the chair.

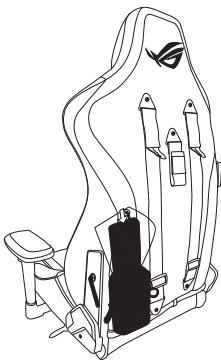

2. Connect the USB Type-A connector to your power bank.

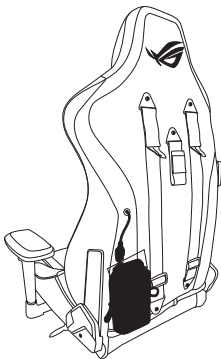

3. The packet is attached to your chair with Velcro. You can easily remove and take it away.

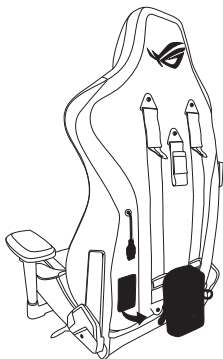

## D Other features

a

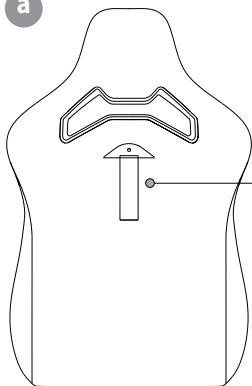

Hanger at the back of the chair for hanging your bags, clothes, cups and more.

Maximum load: 2kg

Please do not hang items over 2kg.

## b Using the RGB controller

Rating: 5V=1A

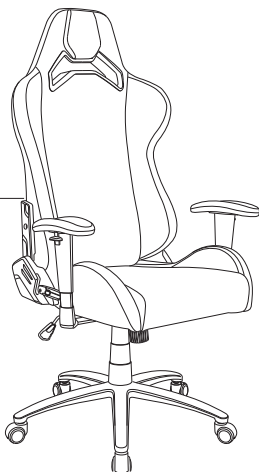
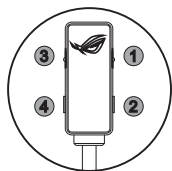

DO NOT remove the non-detachable controller as this will void the warranty.

1. Aura RGB Lighting: On / Effect / Off

Press repeatedly to power the Aura RGB LEDs on or off, or cycle through the current 7 effects: (1) rainbow (2) breathing (3) color cycle (4) wave (5) glowing Yo-Yo (6) strobing (7) static

Press the Aura RGB Lighting button for 3 seconds to terminate the lighting.

Press it to wake up again or reconnect your powerbank will keep its previous setting.

**NOTE:** Your powerbank may automatically adjust its output when the lighting is terminated. Disconnect and reconnect it if the Aura RGB Lighting cannot wake up after toggling it back on.

2. Aura RGB color

Press repeatedly to cycle through the following 8 striking colors: (1) red (2) orange (3) yellow (4) green (5) blue (6) indigo (7) purple (8) pink

**NOTE:** This feature is only available on the following Aura RGB effects: (2) breathing (6) strobing (7) static

3. Aura RGB speed: Slow / Medium / Fast

Press repeatedly to cycle through the following 3 color effect speeds: (1) Slow (2) Medium (3) Fast

**NOTE:** This feature is only available on the following Aura RGB effects: (1) rainbow (2) breathing (3) color cycle (4) wave (5) glowing Yo-Yo (6) strobing

4. Aura RGB brightness: 50% / 75% / 100%

Three brightness levels. The brightness can be switch by simple tap to fit the environment lighting and preference.

5. Reset to factory mode

Press the button (2) and button (4) simultaneously to reset your chair to its factory defaults.

## **E** Adjustable functions

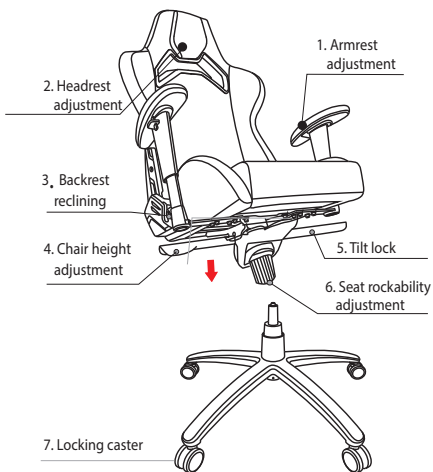

### **1. Armrest adjustment**



1 Height adjustment



2 Forward and backward

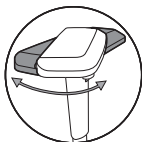

3 Rotation adjustment



4 Inward and outward

## 2. Headrest adjustment

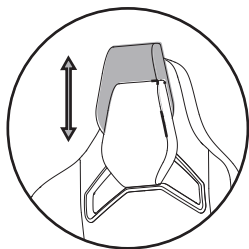

- Height adjustment (6cm)
- Please do not excessively raise your headrest.

## 3. Pull up the lever and slowly lean back.

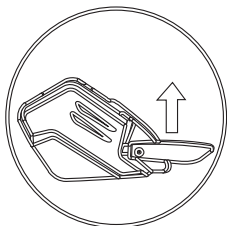

## 4. Chair height adjustment

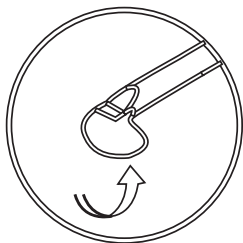

## 5. Lock/unlock the tilt mechanism

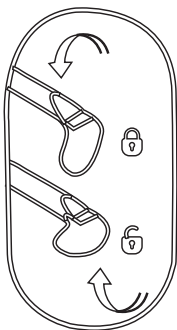

## 6. Seat rockability adjustment

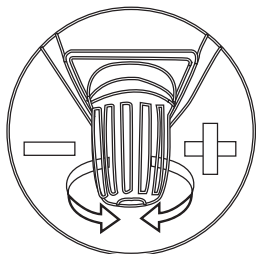

## 7. Locking caster

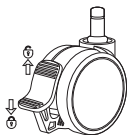



- 请坐在座椅中央，并将背部靠在椅背上。



- 请勿坐在座椅边缘。



- 请勿站在座椅上。



- 当他人坐在椅子上时，请勿调低椅背。



- 请勿将手和手指插入座椅调节配件中。

### 警告！

1. 请正常使用座椅。任何由错误安装或使用导致的损坏，本公司概不负责。
2. 建议最高重量为 120 公斤（264.5 磅）。
3. 请勿错误安装或拆解您的座椅。
4. 请避免阳光直射以保护座椅皮革。
5. 当椅背由躺卧角度恢复至原位时，请小心您的背部。
6. 为避免损坏您的座椅，请不要过度用力拉您的头枕。
7. 请勿尝试打开或触摸 LED 模块，这可能会令保修失效。
8. 本产品电源输入功率为 5V/1A。请勿使用输出功率超过 5V/3A 的电源适配器。



## A

## 包装内容物

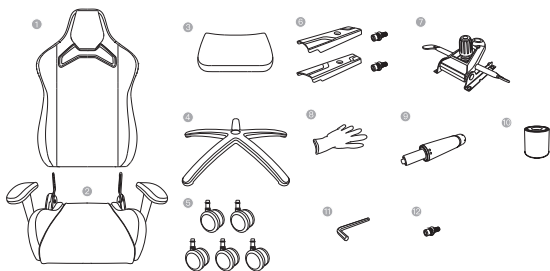

1.	椅背	5.	万向轮	9.	气杆
2.	坐垫	6.	椅背侧盖及螺丝	10.	气杆护套
3.	腰靠	7.	蝴蝶盘	11.	六角扳手
4.	五星脚	8.	安装手套	12.	备用螺丝

注意：此部分说明仅供参考，实物外观与特点或有所差别。

## B 座椅安装步骤

安装前请带上保护手套。

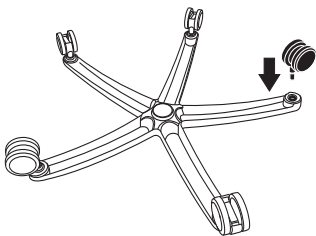

- 1 将 5 个轮子分别插入五星脚每个孔中。

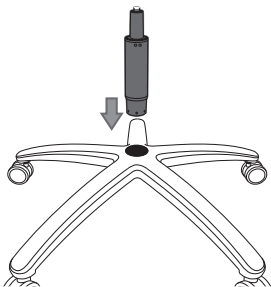

- 2 将气杆插入椅腿中心孔中。若顶部有红色防护帽，请先将其取下。

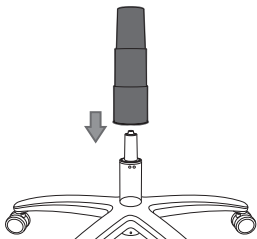

- 3 套上气杆护套。

通常情况下，除非另行说明，扶手不区分左右侧。

若您购买的 ROG 电竞椅已预装扶手，请跳过此步骤。

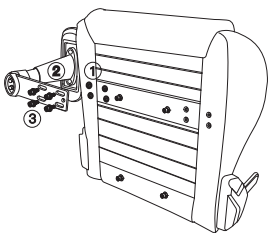

- 4 拆下预装的螺丝与垫片（① & ③）。在扶手固定杆（②）与坐垫之间放置 4 个大垫圈（①），并将扶手固定至合适位置。随后插入 4 个螺丝（③）并使用六角扳手将其锁紧，另一侧重复上述步骤。

- 5 使用六角扳手拆下椅背上预装的螺丝与垫片。

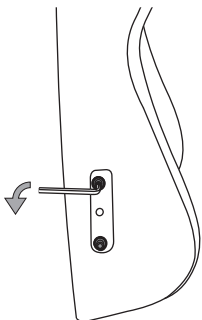

- 6 从坐垫椅背上拆下保护泡沫罩。将椅背放在坐垫支架之间，对准螺丝孔，插入并拧紧步骤 5 拆下的所有 4 个螺丝（每侧两个），并使用六角扳手将其锁紧。请先安装每侧顶部的 2 个螺丝，安装完成后，继续安装底部的 2 个。

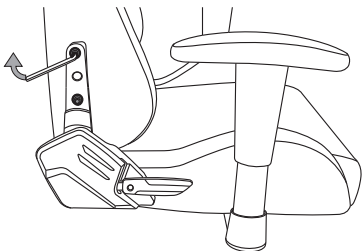

- 7 装上椅背侧盖（两侧），并拧紧螺丝（侧盖内侧注有 L：左侧，R：右侧）。

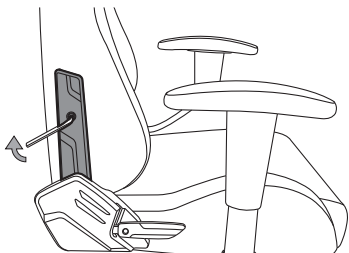

- 8 将整个椅子翻转过来，面朝下，然后从底部卸下 4 个预装螺丝以及垫圈。

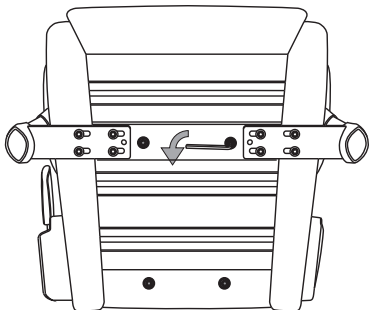

- 9 直接安装蝴蝶盘并锁紧螺丝。请确认“向前”箭头指向椅子的前部，并且座椅高度调节手柄与椅背调节手柄在同侧。

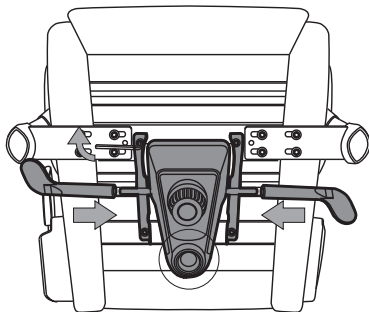

- 10 将座椅主体与腿部连接到位（因座椅用材厚实较重，此步骤建议两人协作完成）。

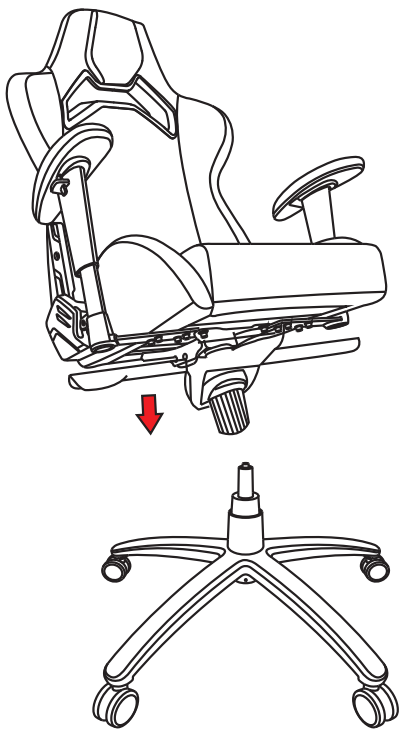

## C 点亮您的座椅

1. 将移动电源放在座椅后侧的便携包中。

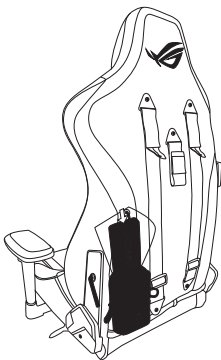

2. 将 USB Type-A 接头连接至移动电源。

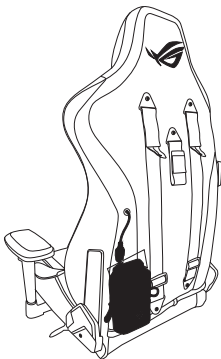

3. 便携包可用尼龙搭扣扣于座椅上，也可以轻松拆除并带走。

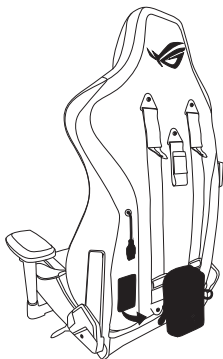

## D 其他功能

a

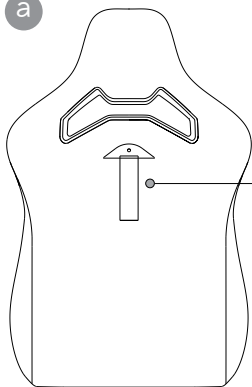

座椅背部配有挂钩，可悬挂背包、衣服、水杯等物品。  
最大负重：2 千克  
请不要悬挂重量超过 2 千克的物品。

## b 使用 RGB 控制器

额定电压电流：5V=1A

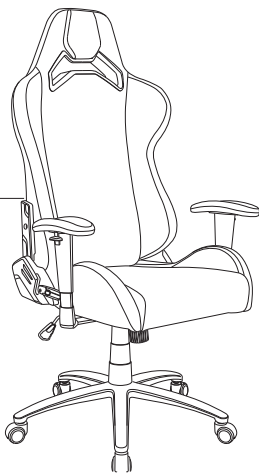
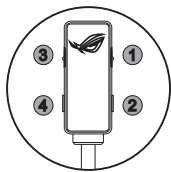

请勿移除非可拆式控制器，否则保修将无效。



### 1. Aura RGB 灯效：开启 / 灯效 / 关闭

重复按下此按钮以开启或关闭 Aura RGB LED，或在 7 种现有灯效间循环：

(1) 彩虹 (2) 呼吸 (3) 颜色循环 (4) 波纹 (5) 溜溜球 (6) 频闪 (7) 恒亮

按下 Aura RGB 灯效按钮 3 秒，关闭灯光。

再次按下按钮唤醒设备或重启移动电源将保持上一设置。

注意：关闭灯效后，移动电源将会自动调节电源输出功率。若 Aura RGB 灯效在按下按钮后没有反应，请拔掉 USB 线并重新连接。

### 2. Aura RGB 颜色

重复单击此按钮可于特定灯效中切换 8 种颜色：

(1) 红色 (2) 橘色 (3) 黄色 (4) 绿色 (5) 蓝色 (6) 靛蓝色 (7) 紫色 (8) 粉红色

注意：此功能仅在下列 Aura RGB 灯效下可用 - (2) 呼吸 (6) 频闪 (7) 恒亮。

### 3. Aura RGB 速度：慢/中/快

重复单击此按钮可在下列 3 种速度中切换：(1) 慢 (2) 中 (3) 快

注意：此功能仅在下列 Aura RGB 灯效下可用：(1) 彩虹 (2) 呼吸 (3) 颜色循环 (4) 波纹 (5) 溜溜球 (6) 频闪

### 4. Aura RGB 亮度：50% / 75% / 100%

亮度级别有 3 种，轻击即可切换亮度以适应环境光源及个人喜好。

### 5. 恢复至出厂默认模式

同时按下按钮 (2) 和 (4) 以将您的座椅恢复为出厂默认状态。

## E 调节功能

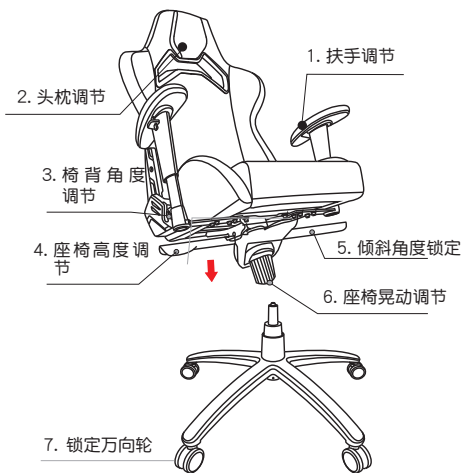

### 1. 扶手调节

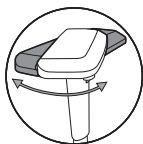

## 2. 头枕调节

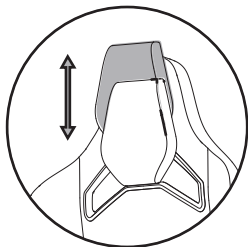

- 高度调节（6 厘米）
- 请不要过度抬高您的头枕。

## 3. 向上提动气杆并将身体慢慢向后倾斜。

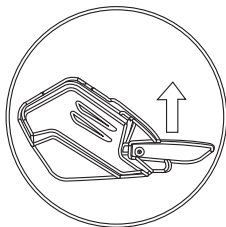

## 4. 座椅高度调节

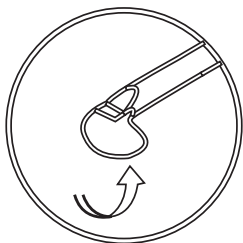

## 5. 固定倾斜角度

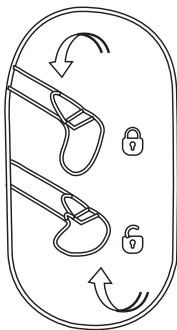

## 6. 座椅晃动调节

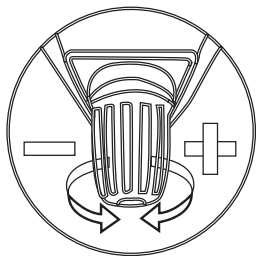

## 7. 锁定万向轮

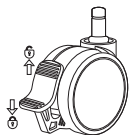

## 安全注意事項



- 請坐在座椅中央，並將背部靠在椅背上。



- 請勿坐在座椅邊緣。



- 請勿站在座椅上。



- 當他人坐在椅子上時，請勿調低椅背。



- 請勿將手和手指插入座椅調節配件中。

## 警示！

- 請正常使用座椅。任何由錯誤安裝或使用導致的損毀，本公司概不負責。
- 建議最高重量為 120kg ( 264.5 pounds ) 。
- 請勿錯誤安裝或拆解您的座椅。
- 請避免陽光直射以保護座椅皮革。
- 當椅背由躺臥角度恢復至原位時，請小心您的背部。
- 為避免損毀您的座椅，請不要過度用力拉您的頭枕。
- 請勿嘗試打開或觸摸 LED 模組，這可能會令保固失效。
- 本產品電源輸入功率為 5V/1A。請勿使用輸出功率超過 5V/3A 的電源變壓器。

## A

## 包裝內容物

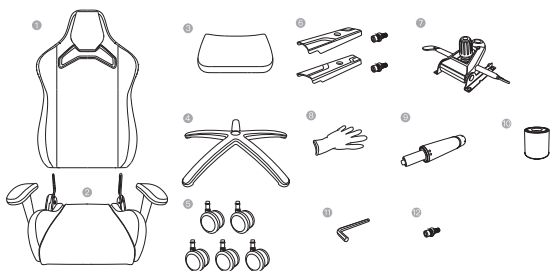

1.	椅背	5.	萬向輪	9.	氣桿
2.	坐墊	6.	椅背側蓋及螺絲	10.	氣桿護套
3.	腰靠	7.	蝴蝶盤	11.	六角扳手
4.	五星腳	8.	安裝手套	12.	備用螺絲

注意：此部分說明僅供參考，實物外觀與特點或有所差別。

## B 座椅安裝步驟

安裝前請帶上保護手套。

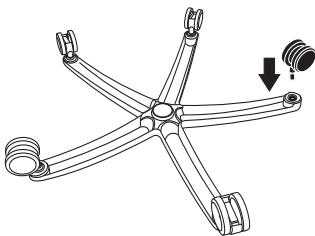

- 1 將 5 個輪子分別插入五星腳每個孔中。

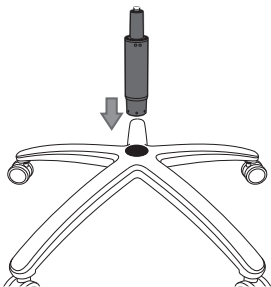

- 2 將氣桿插入椅腿中心孔中。若頂部有紅色防護帽，請先將其取下。

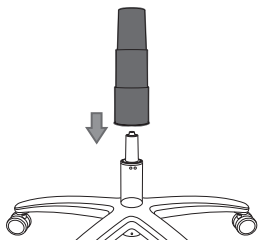

- 3 套上氣桿護套。

通常情況下，除非另行說明，扶手不區分左右側。

若您購買的 ROG 電競椅已預裝扶手，請跳過此步驟。

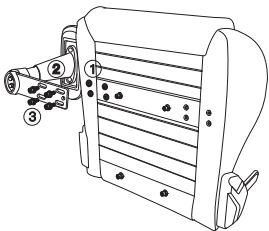

- 4 拆下預裝的螺絲與墊片（① & ③）。在扶手固定桿（②）與坐墊之間放置 4 個大墊圈（①），並將扶手固定至合適位置。隨後插入 4 個螺絲（③）並使用六角扳手將其鎖緊，另一側重複上述步驟。

- 5 使用六角扳手拆下椅背上預裝的螺絲與墊片。

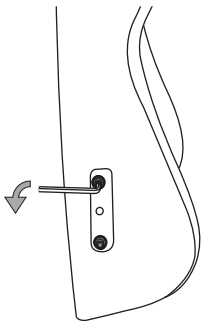

- 6 從坐墊椅背上拆下保護泡沫罩。將椅背放在坐墊支架之間，對準螺絲孔，插入並擰緊步驟 5 拆下的所有 4 個螺絲（每側兩個），並使用六角扳手將其鎖緊。請先安裝每側頂部的 2 個螺絲，安裝完成後，繼續安裝底部的 2 個。

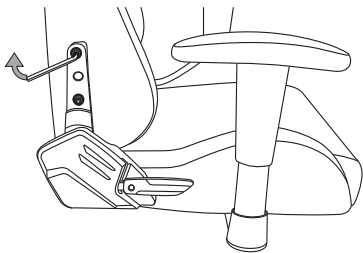



- 7 裝上椅背側蓋（兩側），並擰緊螺絲（側蓋內側注有 L：左側，R：右側）。

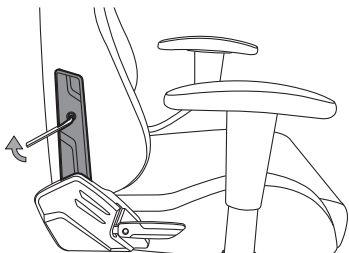

- 8 將整個椅子翻轉過來，面朝下，然後從底部卸下 4 個預裝螺絲以及墊圈。

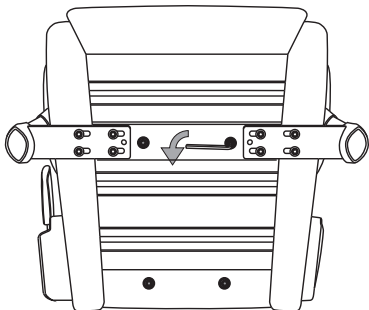

- 9 直接安裝蝴蝶盤并鎖緊螺絲。請確認「向前」箭頭指向椅子的前部，並且座椅高度調節手柄與椅背調節手柄在同側。

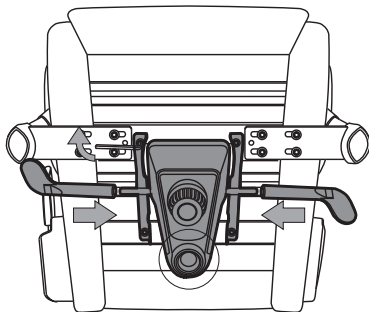

- 10 將座椅主體與腿部連接到位（因座椅用材厚實較重，此步驟建議兩人協作完成）。

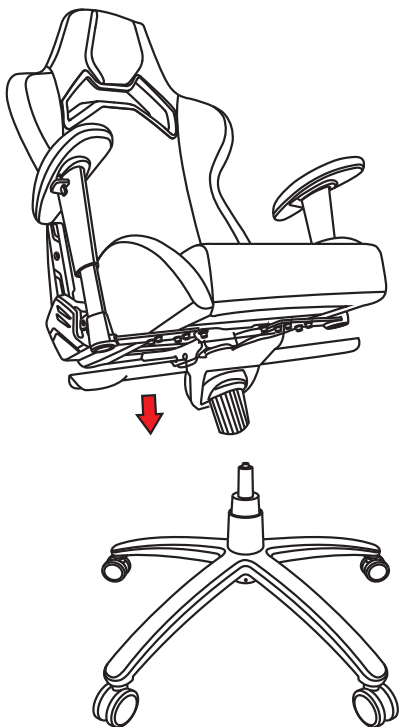



## 點亮您的座椅

1. 將行動電源放在座椅後側的便攜包中。

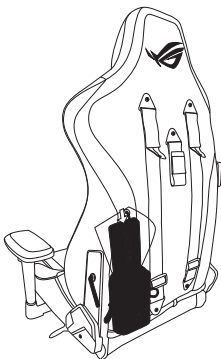

2. 將 USB Type-A 接頭連接至行動電源。

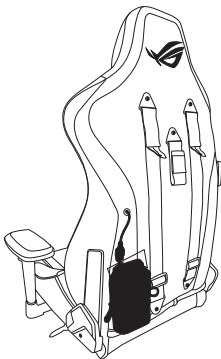

3. 便攜包可用尼龍搭扣扣於座椅上，也可以輕鬆拆除並帶走。

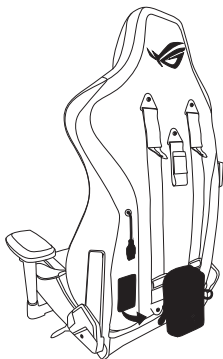

## D 其他功能

a

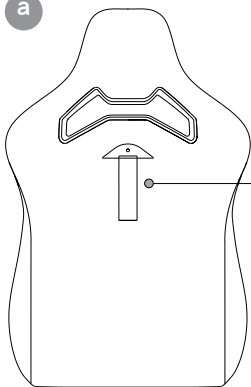

座椅背部配有掛鉤，可懸掛背包、衣服、水杯等物品。

最大負重：2 kg

請不要懸掛重量超過 2 kg 的物品。

## b 使用 RGB 控制器

額定電壓電流：5V=1A

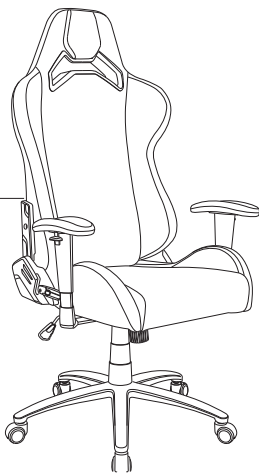
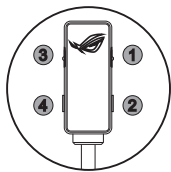

請勿移除非可拆式控制器，否則保固將無效。

### 1. Aura RGB 燈效：開啟 / 燈效 / 關閉

重複按下此按鈕以開啟或關閉 Aura RGB LED，或在 7 種現有燈效間循環：

(1) 彩虹 (2) 呼吸 (3) 顏色循環 (4) 波紋 (5) 溜溜球 (6) 頻閃 (7) 恆亮

按下 Aura RGB 燈效按鈕 3 秒，關閉燈光。

再次按下按鈕喚醒裝置或重啟行動電源將保持上一設定。

**注意：** 關閉燈效後，行動電源將會自動調節電源輸出功率。若 Aura RGB 燈效在按下按鈕後沒有反應，請拔掉 USB 線並重新連接。

### 2. Aura RGB 顏色

重複單擊此按鈕可於特定燈效中切換 8 種顏色：

(1) 紅色 (2) 橘色 (3) 黃色 (4) 綠色 (5) 藍色 (6) 靛藍色 (7) 紫色 (8) 粉紅色

**注意：** 此功能僅在下列 Aura RGB 燈效下可用 - (2) 呼吸 (6) 頻閃 (7) 恆亮。

### 3. Aura RGB 速度：慢/中/快

重複單擊此按鈕可在下列 3 種速度中切換：(1) 慢 (2) 中 (3) 快

**注意：** 此功能僅在下列 Aura RGB 燈效下可用：(1) 彩虹 (2) 呼吸 (3) 顏色循環 (4) 波紋 (5) 溜溜球 (6) 頻閃

### 4. Aura RGB 亮度：50% / 75% / 100%

亮度級別有 3 種，輕擊即可切換亮度以適應環境光源及個人喜好。

### 5. 回復至原廠預設模式

同時按下按鈕 (2) 和 (4) 以將您的座椅重置為原廠預設狀態。

## E 調節功能

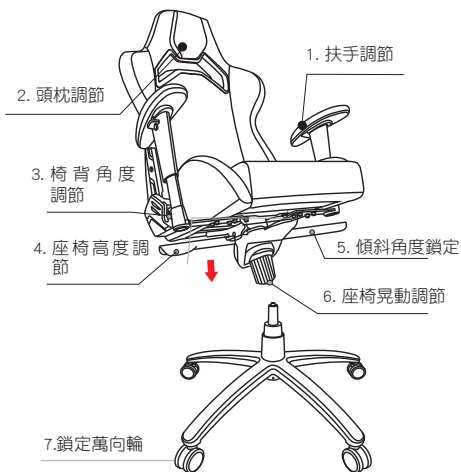

### 1. 扶手調節

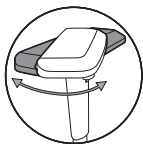

## 2. 頭枕調節

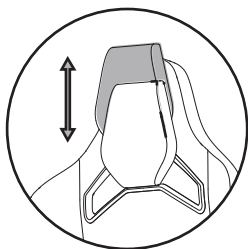

- 高度調節 (6cm)
- 請不要過度抬高您的頭枕。

## 3. 向上提動氣桿並將身體慢慢向後傾斜。

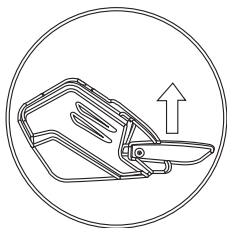

## 4. 座椅高度調節

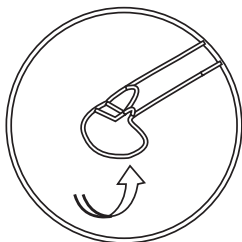

## 5. 固定傾斜角度

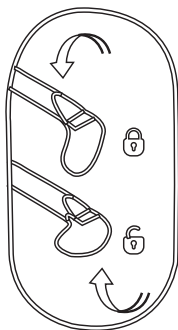



## 6. 座椅晃動調節

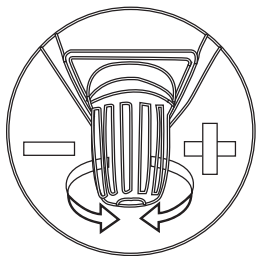

## 7. 鎖定萬向輪

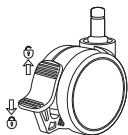

## Avertissements de sécurité



- Asseyez-vous au centre du fauteuil, votre dos collé au dossier.



- Ne vous asseyez pas sur le bord du fauteuil.



- Ne vous tenez pas debout sur le fauteuil.



- Ne vous appuyez pas sur le dossier incliné lorsqu'une personne s'y trouve.



- Tenez vos mains et vos doigts à l'écart du mécanisme d'inclinaison.

## AVERTISSEMENT !

1. Ce fauteuil est conçu pour un usage normal et non abusif. Nous ne pourrions être tenus responsables de tout dommage provoqué par un montage et/ou un usage inappropriés.
2. La charge maximale recommandée est de 120KG.
3. Ne jamais monter ou démonter votre fauteuil de manière inappropriée.
4. Veuillez garder votre fauteuil à l'abri du soleil afin de préserver son cuir.
5. Veuillez prendre des précautions lorsque le dossier revient dans sa position initiale depuis une position inclinée.
6. Afin d'éviter d'endommager votre fauteuil, veuillez ne pas appliquer une force trop grande en soulevant l'appuie-tête.
7. Ne tentez jamais d'ouvrir et de toucher au module LED, ce qui aurait pour effet d'annuler la garantie.
8. Le courant d'entrée nominal pour ce produit est de 5V/1A. N'utilisez pas un adaptateur secteur avec un courant de sortie excédant 5V/3A.

## A Contenu de la boîte

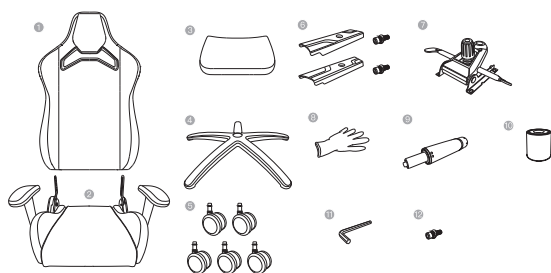

1.	Dossier	5.	Roues	9.	Vérin de levage hydraulique
2.	Assise	6.	Caches latéraux avec boulons	10.	Couverture télescopique
3.	Coussin lombaire	7.	Dispositif de contrôle	11.	Clé hexagonale
4.	Empattement	8.	Gants	12.	Boulon de rechange

**REMARQUE :** Les illustrations sont fournies à titre indicatif uniquement, l'apparence et les caractéristiques du fauteuil peuvent varier.

## B Assembler votre fauteuil

Mettez les gants avant de procéder à l'installation.

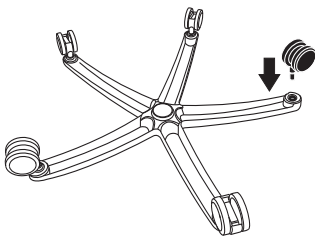

- 1 Insérez et poussez les roues l'une après l'autre dans la base.

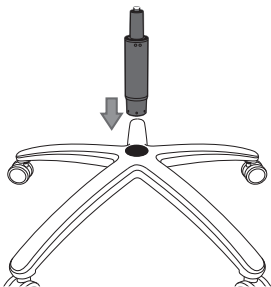

- 2 Insérez le vérin de levage hydraulique dans le trou central de la base. Retirez le couvercle de protection rouge, s'il y en a un.

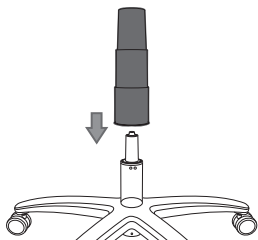

- 3 Placez le couvercle télescopique sur le dessus du vérin de levage hydraulique.

Les deux accoudoirs sont normalement identiques, sauf indication contraire.

Pour les modèles avec accoudoirs pré-assemblés, veuillez ignorer cette étape.

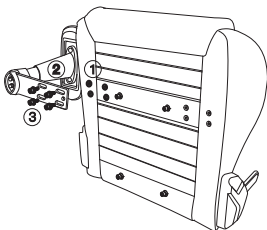

- 4 Retirez les boulons et les rondelles pré-assemblés (1 et 3). Placez les 4 grandes rondelles (1) entre la barre de montage de l'accoudoir (2) et l'assise. Tenez l'accoudoir en place, puis insérez et serrez tous les 4 boulons (3). Utilisez la clé hexagonale pour les serrer et répétez cette étape de l'autre côté.

- 5 Utilisez la clé hexagonale pour retirer les boulons et les rondelles pré-assemblés du dossier.

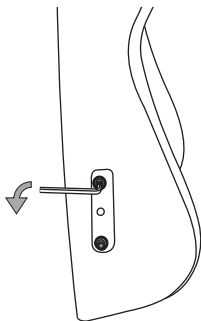

- 6 Retirez les protections en mousse des supports de l'assise. Positionnez ensuite délicatement le dossier entre les supports. Insérez et attachez premièrement à la main les 4 boulons (2 de chaque côté) précédemment retirés à l'étape 5. Puis, utilisez la clé hexagonale pour les serrer. Commencez avec les deux boulons sur le dessus de chaque côté, puis continuez avec les deux boulons du dessous.

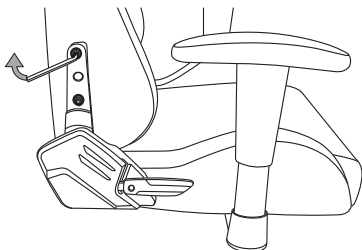

- 7 Installez les couvercles latéraux et serrez les boulons. (À l'intérieur des couvercles, l'inscription "L" désigne le côté gauche et l'inscription "R" désigne le côté droit.)

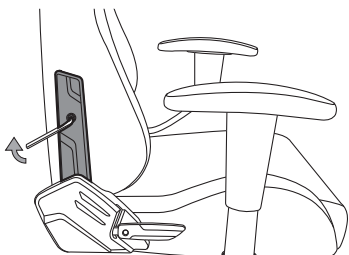

- 8 Maintenant, retournez le fauteuil vers le bas. Retirez ensuite les 4 boulons pré-montés du dessous avec des rondelles.

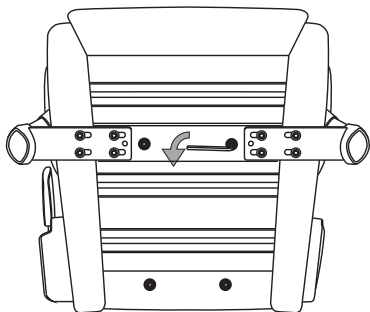

- 9 Répétez l'étape ci-dessus pour installer le boîtier de commande, puis placez l'écrou pour monter le vérin de levage hydraulique face à l'arrière du siège (où le dossier est installé).

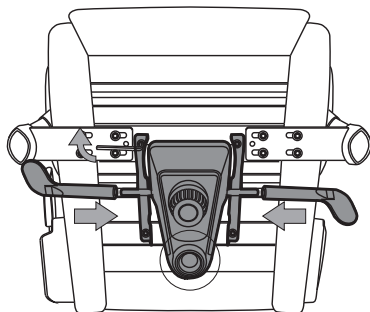

- 10 Insérez le haut du vérin de levage hydraulique dans le trou de montage du boîtier de commande, puis retournez le fauteuil en position verticale. (Pour votre sécurité, effectuez cette manipulation à deux personnes).

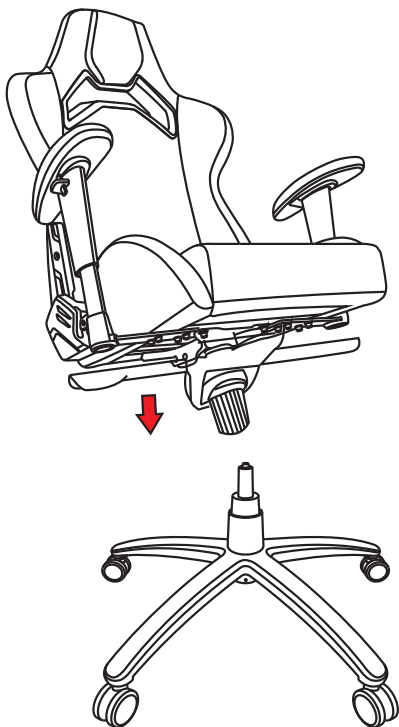

## C Illuminer votre fauteuil

1. Placez votre batterie externe dans la poche située au dos du fauteuil.

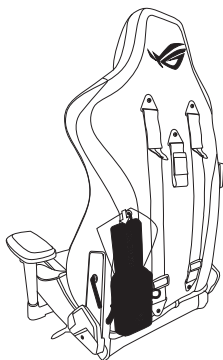

2. Branchez le connecteur USB Type-A à votre batterie externe.

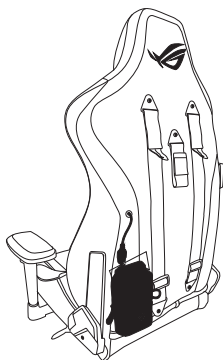



3. La poche est attachée à votre fauteuil avec du velcro. Vous pouvez la retirer et l'emporter facilement.

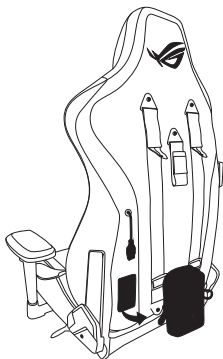

## D Autres fonctionnalités

a

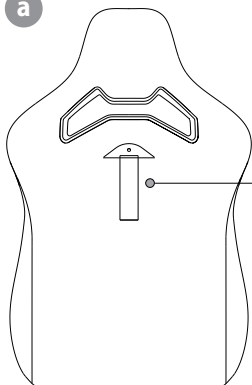

Crochet au dos du fauteuil pour suspendre vos sacs, vêtements, tasses et plus encore.

Charge maximale : 2kg

Veillez ne pas suspendre d'objets de plus de 2kg.

## b Utilisation de la manette de contrôle de RGB

Tension nominale : 5V=1A

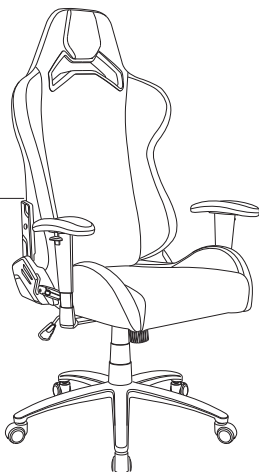
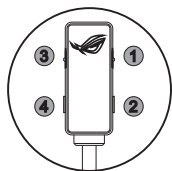

Ne tentez pas de retirer la manette non amovible, ce qui aurait pour effet d'annuler la garantie.

1. Éclairage Aura RGB : Activé/ Effet / Désactivé

Appuyez à plusieurs reprises pour activer/désactiver les LED Aura RGB ou pour alterner entre les 7 effets lumineux : (1) arc-en-ciel (2) pulsation (3) cycle de couleurs (4) vague (5) Yo-Yo lumineux (6) stroboscopique (7) statique

Appuyez sur le bouton d'éclairage Aura RGB pendant 3 secondes pour arrêter l'éclairage. Presser à nouveau le bouton pour activer l'éclairage ou reconnecter la batterie externe conservera les réglages précédents.

**REMARQUE :** Votre batterie amovible est susceptible d'ajuster automatiquement son courant de sortie lorsque l'éclairage est désactivé. Déconnectez et reconnectez votre batterie externe si l'éclairage Aura RGB ne s'allume pas lorsque vous l'activez à nouveau.

2. Couleur Aura RGB

Appuyez à plusieurs reprises pour alterner entre les 8 couleurs suivantes : (1) rouge (2) orange (3) jaune (4) vert (5) bleu (6) indigo (7) violet (8) rose

**REMARQUE :** Cette fonction est uniquement disponible avec les effets Aura RGB suivants : (2) pulsation (6) stroboscopique (7) statique

3. Vitesse Aura RGB : Lent / Moyen / Rapide

Appuyez à plusieurs reprises pour alterner entre les 3 vitesses d'effets lumineux : (1) Lent (2) Moyen (3) Rapide

**REMARQUE :** Cette fonction est uniquement disponible avec les effets Aura RGB suivants : (1) arc-en-ciel (2) pulsation (3) cycle de couleurs (4) vague (5) Yo-Yo lumineux (6) stroboscopique

4. Luminosité Aura RGB : 50% / 75% / 100%

Trois niveaux de luminosité. La luminosité peut être modifiée par une simple pression afin de s'adapter à la lumière ambiante et à vos préférences.

5. Restauration des paramètres par défaut

Appuyez sur les boutons (2) et (4) simultanément pour restaurer les paramètres par défaut du fauteuil.

## E Fonctions réglables

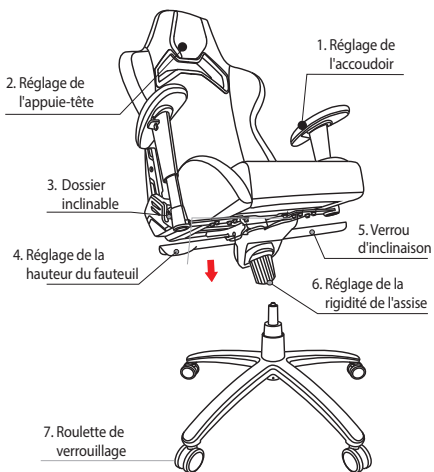

### 1. Réglage de l'accoudoir

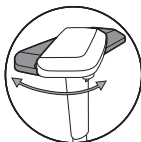

## 2. Réglage de l'appuie-tête

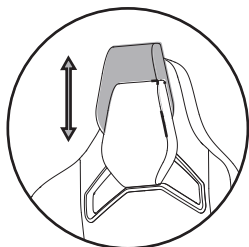

- Réglage de la hauteur (6cm)
- Veuillez ne pas élever votre appuie-tête de manière excessive.

## 3. Tirez sur le levier et penchez-vous doucement en arrière.

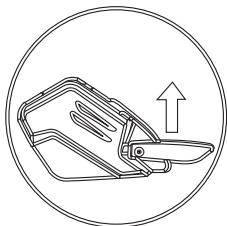

## 4. Réglage de la hauteur du fauteuil

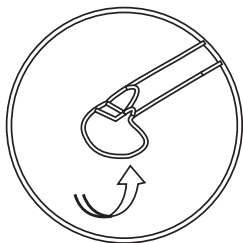

## 5. Verrouiller/déverrouiller le mécanisme d'inclinaison

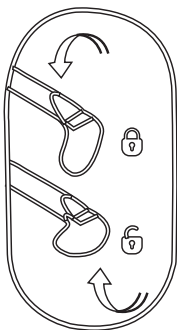

## 6. Réglage de la rigidité de l'assise

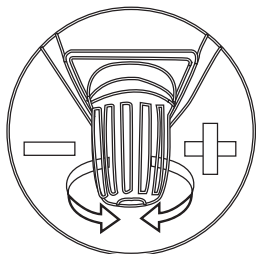

## 7. Roulette de verrouillage

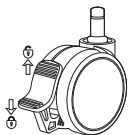

## Sicherheitshinweise



- Setzen Sie sich, mit Ihrem Rücken an der Rückenlehne, mittig in den Stuhl.



- Setzen Sie sich nicht auf die Stuhlkante.



- Stellen Sie sich nicht auf den Stuhl.



- Drücken Sie die Rückenlehne nicht nach unten, wenn sie sich in einer zurückgelehnten Position befindet und eine Person auf dem Stuhl sitzt.



- Halten Sie Ihre Finger von der Rückstellvorrichtung fern.

## WARNUNG!

1. Dieser Stuhl darf nur auf normale Weise und nicht missbräuchlich verwendet werden. Es besteht keine Haftung für Schäden, die aus unsachgemäßer Montage und/oder Verwendung entstehen.
2. Das empfohlene Maximalgewicht, mit dem der Stuhl belastet werden kann, beträgt 120 kg.
3. Bauen Sie Ihren Stuhl nie in unsachgemäßer Weise zusammen oder auseinander.
4. Bitte setzen Sie Ihren Stuhl keiner direkten Sonneneinstrahlung aus, um das Leder zu schonen.
5. Bitte geben Sie auf Ihren Rücken acht, wenn Sie die Rückenlehne aus einer zurückgelehnten Position wieder in die ursprüngliche Position stellen.
6. Wenden Sie bitte zur Vermeidung von Beschädigungen an Ihrem Stuhl keine übermäßige Kraft an, um Ihre Kopflehne hochzuziehen.
7. Versuchen Sie NIE, das LED-Modul zu öffnen und zu berühren, da dadurch die Garantie erlischt.
8. Die Stromeingangsleistung für dieses Produkt beträgt 5V/1A. Verwenden Sie kein Netzteil mit einer Stromausgangsleistung von mehr als 5V/3A.

## A Verpackungsinhalt

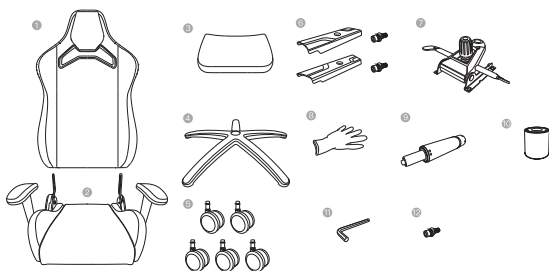

1.	Rückenlehne	5.	Rollen	9.	Hydraulischer Hubzylinder
2.	Sitzfläche	6.	Seitenabdeckungen mit Schrauben	10.	Teleskop-Abdeckung
3.	Lendenstützpolster	7.	Sitzhöhenregler	11.	Inbusschlüssel
4.	Rollenstandfuß	8.	Handschuhe	12.	Ersatzschraube

**HINWEIS:** Die Abbildungen dienen nur der Veranschaulichung, Ihr tatsächlicher Stuhl kann in Aussehen und Ausstattung abweichen.



## B Montage Ihres Stuhls

Ziehen Sie vor dem Aufbau die Handschuhe an.

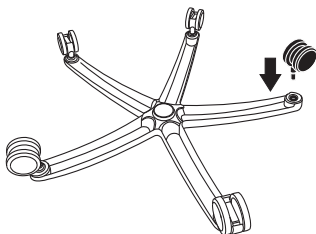

- 1 Stecken und drücken Sie die Rollen nacheinander in den Standfuß.

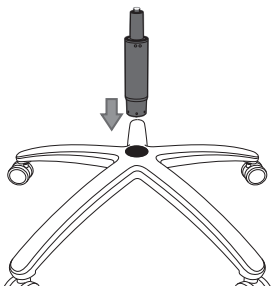

- 2 Stecken Sie den hydraulischen Hubzylinder in die Öffnung in der Mitte des Standfußes. Entfernen Sie, falls vorhanden, die rote Schutzkappe auf der Oberseite.

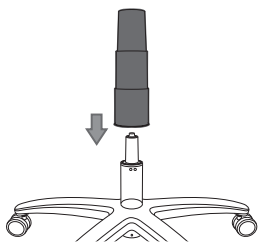

- 3 Bringen Sie die Teleskop-Abdeckung auf dem hydraulischen Hubzylinder an.

Die Armlehnen werden normalerweise nicht nach der Seite unterschieden, es sei denn, sie sind dementsprechend gekennzeichnet.

Bei Modellen mit vormontierten Armlehnen überspringen Sie bitte diesen Schritt.

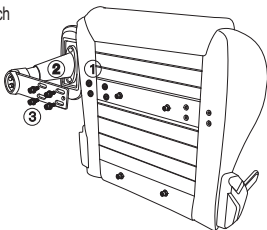

- 4 Entfernen Sie die schon eingesetzten Schrauben und Unterlegscheiben (1 & 3). Platzieren Sie die vier großen Unterlegscheiben (1) zwischen der Montageschiene der Armlehne (2) und der Sitzfläche. Halten Sie die Armlehne in Position, bringen Sie dann alle vier Schrauben an und ziehen Sie sie fest (3). Benutzen Sie den Inbusschlüssel zum Festziehen und wiederholen Sie die Prozedur auch auf der anderen Seite.

- 5 Benutzen Sie den Inbusschlüssel, um die schon eingesetzten Schrauben und Unterlegscheiben an der Rückenlehne zu entfernen.

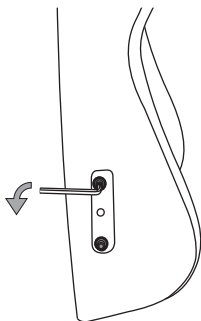

- 6 Entfernen Sie die Schaumstoffschutzabdeckungen von den Halterungen der Sitzfläche. Platzieren Sie dann die Rückenlehne vorsichtig zwischen den Halterungen. Setzen Sie die vier Schrauben ein, die Sie in Schritt 5 entfernt haben, und befestigen Sie sie (zwei auf jeder Seite) zunächst von Hand. Benutzen Sie dann den Inbusschlüssel zum Festziehen. Beginnen Sie mit den beiden oberen Schrauben auf jeder Seite, fahren Sie dann mit den beiden unteren fort.

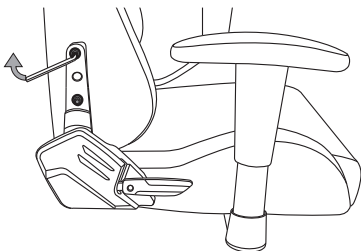

- 7 Montieren Sie die Seitenabdeckungen und ziehen Sie die Schrauben fest. (Die Abdeckungen sind auf der Innenseite mit "L" für die linke Seite und "R" für die rechte Seite gekennzeichnet.)

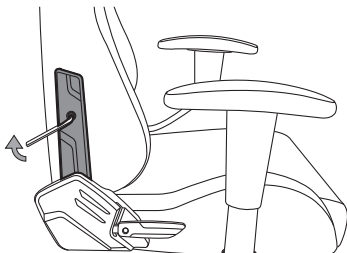

- 8 Drehen Sie den Stuhl nun um, so dass er nach unten gewandt ist. Entfernen Sie dann die vier schon eingesetzten Schrauben samt Unterlegscheiben von der Unterseite.

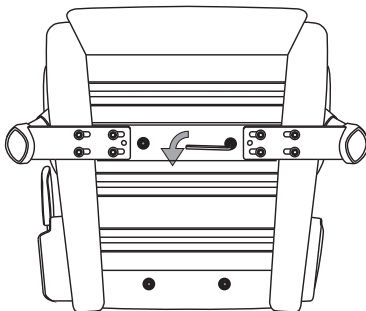

- 9 Wiederholen Sie zur Montage des Sitzhöhenreglers den obigen Schritt und platzieren Sie dann die Gewindemutter zum Befestigen des hydraulischen Hubzylinders an der hinteren Seite des Sitzes (dort wo die Rückenlehne angebracht ist).

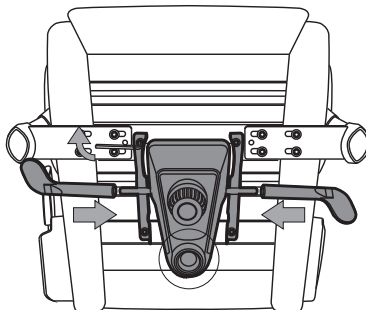

- 10 Stecken Sie die Oberseite des hydraulischen Hubzylinders in das Befestigungsloch am Sitzhöhenregler. Drehen Sie den Stuhl dann in die aufrechte Position um. (Zu Ihrer Sicherheit ist der Aufbau durch zwei Personen erforderlich).

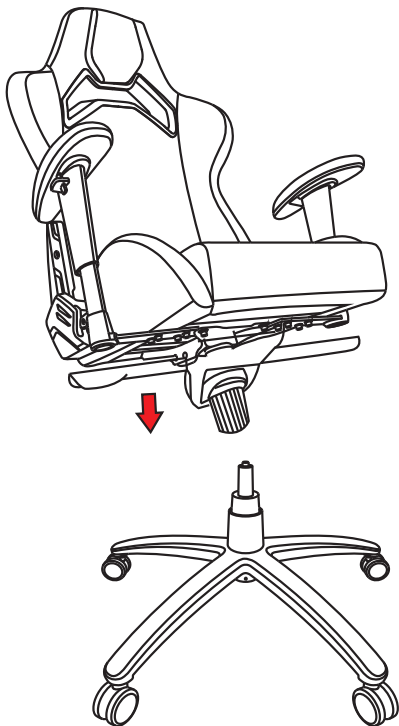

## C Beleuchtung Ihres Stuhls

1. Stecken Sie Ihre Powerbank in die Tasche an der Rückseite des Stuhls.

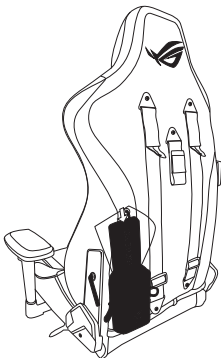

2. Verbinden Sie den USB Typ-A-Stecker mit Ihrer Powerbank.

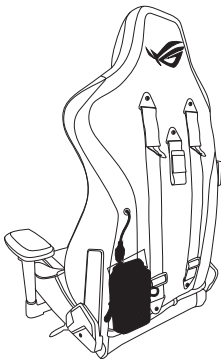

3. Die Tasche ist mit einem Klettverschluss an Ihren Stuhl befestigt. Sie können sie leicht abtrennen und mitnehmen.

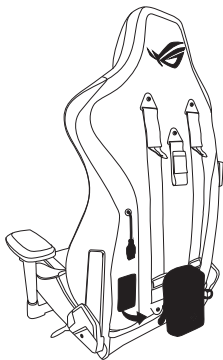

## D Weitere Besonderheiten

a

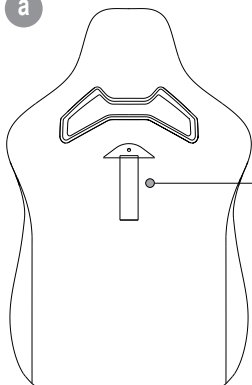

An der Rückseite des Stuhls befindet sich ein Aufhänger, damit Sie Ihre Tasche, Kleidung und vieles mehr daran hängen können.  
Maximale Belastung: 2 kg  
Bitte hängen Sie keine Gegenstände über 2 kg auf.

## b Verwendung des RGB-Controllers

Leistung: 5V=1A

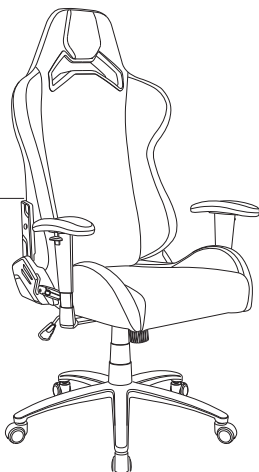
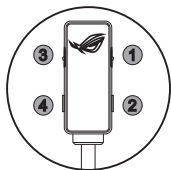

Entfernen Sie NICHT die fest verbaute Steuereinheit, da dadurch die Garantie erlischt.

1. Aura RGB-Beleuchtung: Ein / Effekt / Aus

Drücken Sie wiederholt, um die vorhandenen 7 Effekte zu durchlaufen oder die Aura RGB LEDs ein- oder auszuschalten: (1) Regenbogen (2) Pulsierend (3) Farbwechsel (4) Welle (5) Leuchtendes Jo-Jo (6) Stroboskop (7) Statisch

Drücken Sie die Aura RGB-Beleuchtungstaste 3 Sekunden lang, um die Beleuchtung auszuschalten.

Nach dem Aufwecken durch Drücken oder dem erneuten Verbinden Ihrer Powerbank werden die vorherigen Einstellungen beibehalten.

**HINWEIS:** Ihre Powerbank kann die Stromausgabe automatisch anpassen, wenn die Beleuchtung deaktiviert wird. Falls die Aura RGB-Beleuchtung nach dem erneuten Einschalten nicht zurück in den aktiven Zustand versetzt wird, trennen und verbinden Sie die Powerbank wieder.

2. Aura RGB-Farben

Drücken Sie wiederholt, um die folgenden 8 wirkungsvollen Farben zu durchlaufen:

(1) Rot (2) Orange (3) Gelb (4) Grün (5) Blau (6) Indigoblau (7) Lila (8) Rosa

**HINWEIS:** Diese Funktion ist nur für die folgenden Aura RGB Effekte verfügbar:

(2) Pulsierend (6) Stroboskop (7) Statisch

3. Aura RGB-Geschwindigkeit: Langsam / Mittel / Schnell

Drücken Sie wiederholt, um die folgenden 3 Farbeffektgeschwindigkeiten zu durchlaufen:

(1) Langsam (2) Mittel (3) Schnell

**HINWEIS:** Diese Funktion ist nur für die folgenden Aura RGB Effekte verfügbar: (1) Regenbogen (2) Pulsierend (3) Farbwechsel (4) Welle (5) Leuchtendes Jo-Jo (6) Stroboskop

4. Aura RGB-Helligkeit: 50% / 75% / 100%

Es sind drei Helligkeitsstufen verfügbar. Die Helligkeit kann durch einfaches Tippen umgeschaltet werden, um an das Umgebungslicht und die eigenen Präferenzen angepasst zu werden.

5. Setzen Sie Ihr System auf die Werkseinstellungen zurück

Drücken Sie die Tasten (2) und (4) gleichzeitig, um Ihren Stuhl auf seine Werkseinstellungen zurückzusetzen.



## E Verstellmöglichkeiten

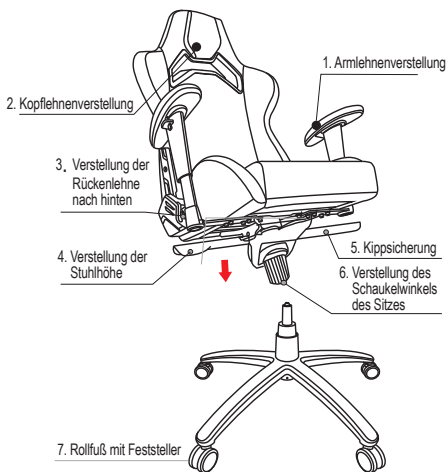

### 1. Armlehnenverstellung

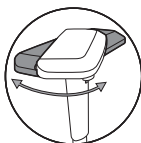

## 2. Kopflehnenverstellung

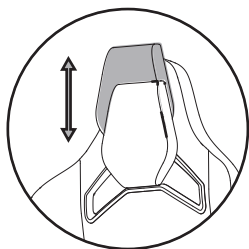

- Höhenverstellung (6 cm)
- Bitte stellen Sie Ihre Kopflehne nicht übermäßig hoch.

## 3. Ziehen Sie den Hebel nach oben und lehnen Sie sich langsam zurück.

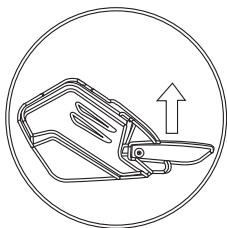

## 4. Verstellung der Stuhlhöhe

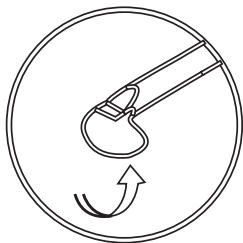

## 5. Sichern/Entsichern des Kippmechanismus

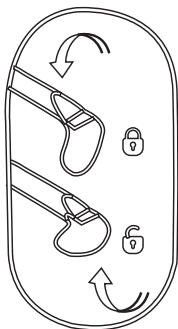

## 6. Verstellung des Schaukelwinkels des Sitzes

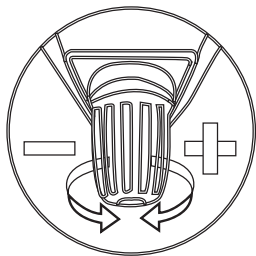

## 7. Rollfuß mit Feststeller

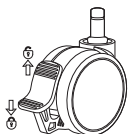

## Comunicazioni sulla sicurezza



- Siediti al centro della sedia, con la schiena appoggiata allo schienale.



- Non sederti sul bordo della sedia.



- Non salire in piedi sulla sedia.



- Non spingere lo schienale reclinato quando una persona si trova sulla sedia.



- Tieni le dita e le mani lontano dal meccanismo di reclinazione.

## AVVERTIMENTO!

1. Questa sedia deve essere usata con cura e cautela. Non siamo responsabili per eventuali danni derivanti da montaggio e/o utilizzo improprio.
2. Il peso massimo consentito è 120 Kg (264.5 libbre).
3. Non smontare o montare la sedia in modo improprio.
4. Al fine di proteggere le parti in pelle tieni la sedia lontano dalla luce solare diretta.
5. Fai attenzione alla schiena quando lo schienale torna alla sua posizione originale da una posizione reclinata.
6. Al fine di evitare danni alla sedia non applicare forza eccessiva quando muovi il poggiatesta.
7. NON provare ad aprire e toccare il modulo LED, se lo fai la garanzia non sarà più valida.
8. La potenza in ingresso per questo prodotto è 5V/1A. Non usare un adattatore di alimentazione con uscita superiore a 5V/3A.

## A Contenuto della confezione

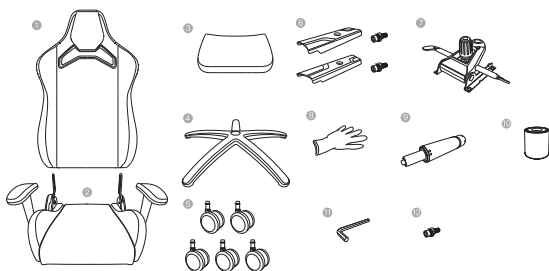

1.	Schienale	5.	Rotelle	9.	Cilindro a sollevamento idraulico
2.	Sedile	6.	Cover laterali con bulloni	10.	Copertura telescopica
3.	Supporto lombare	7.	Unità di controllo	11.	Chiave esagonale
4.	Base a stella	8.	Guanti	12.	Bullone di ricambio

**NOTA:** Le immagini hanno puro scopo illustrativo, le specifiche reali del prodotto potrebbero variare nell'aspetto e nella funzione.

## B Assemblaggio della sedia

Indossa i guanti prima di procedere all'installazione.

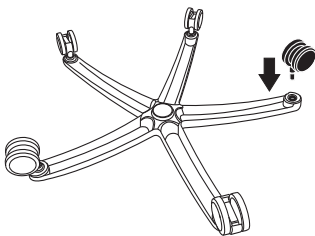

- 1 Inserisci le rotelle, una per una, nella base a stella.

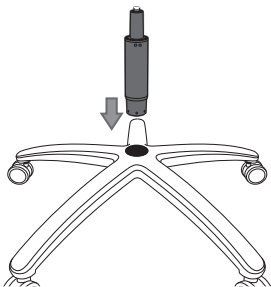

- 2 Inserisci il cilindro a sollevamento idraulico nel foro centrale della base a stella. Rimuovi il cappuccio rosso protettivo dalla parte superiore, se presente.

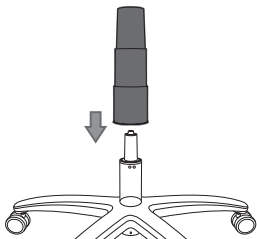

- 3 Installa la cover telescopica sul cilindro a sollevamento idraulico.

I braccioli possono essere installati su entrambi i lati, a meno che sia specificato diversamente.

Se la tua sedia è dotata di braccioli pre-assemblati puoi saltare questo passaggio.

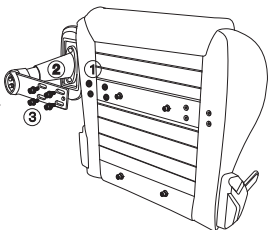

- 4 Rimuovi i bulloni e le rondelle pre-assemblati (1 & 3). Posiziona le 4 rondelle più grandi (1) tra la barra di montaggio dei bracciolo (2) e il sedile. Tieni fermo il bracciolo quindi inserisci e stringi i 4 bulloni (3). Per stringere i bulloni puoi usare la chiave esagonale, poi ripeti il processo sull'altro lato.

- 5 Usa la chiave esagonale per rimuovere i bulloni e le rondelle pre-assemblati dallo schienale.

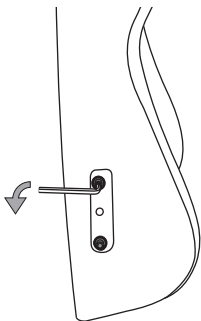

- 6 Rimuovi le cover laterali dalla parte inferiore dello schienale. Inserisci con cura lo schienale in corrispondenza delle staffe di montaggio. Usando solo le mani inserisci e stringi i 4 bulloni (2 per lato) che hai rimosso nel passaggio 5. In seguito usa la chiave esagonale per stringerli. Inizia dai 2 bulloni in alto, su ciascun lato, poi passa ai due bulloni in basso.

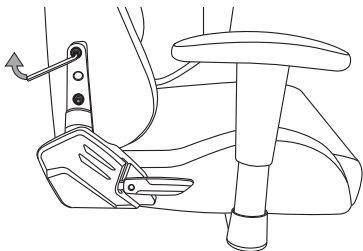

- 7 Installa le cover laterali e stringi i relativi bulloni. (All'interno di ciascuna cover è indicato il lato corretto: "L" per sinistra, "R" per destra.)

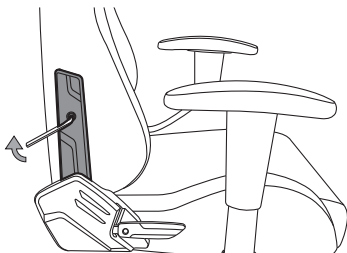

- 8 Ora capovolgi la sedia in modo che sia rivolta verso il basso. Rimuovi i 4 bulloni pre-assemblati e le relative rondelle dalla parte inferiore.

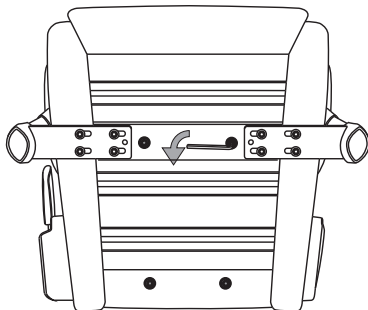

- 9 Ripeti il passaggio precedente per installare l'unità di controllo, quindi posiziona il dado per installare il cilindro a sollevamento idraulico in modo che sia rivolto verso il retro del sedile (dove è installato lo schienale).

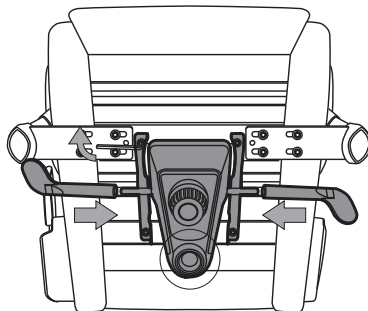



- 10 Ruotando la sedia in posizione verticale inserisci la parte superiore del cilindro a sollevamento idraulico nel foro di montaggio dell'unità di controllo. (Per sicurezza consigliamo l'intervento di due persone).

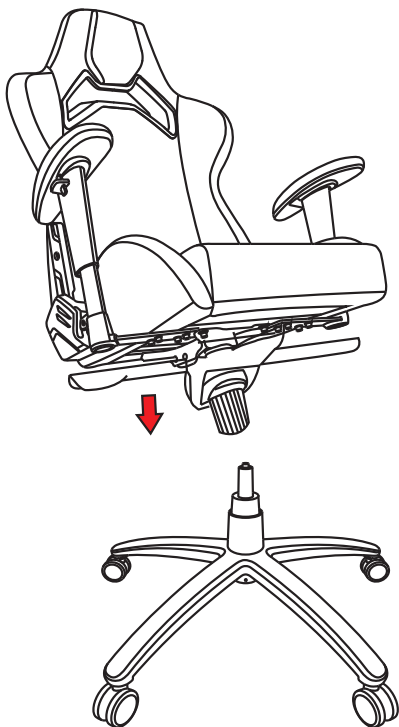

## C Installazione del supporto lombare

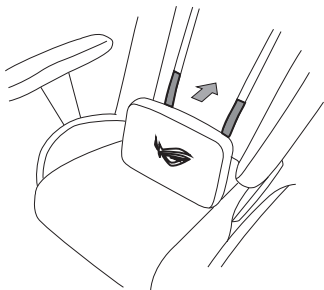
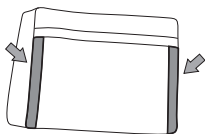

La sedia e il supporto lombare sono dotati di chiusure in velcro. Collega il supporto lombare alla sedia usando le chiusure in velcro.

## D Illuminazione della sedia

1. Inserisci il power bank nella tasca sul retro della sedia.

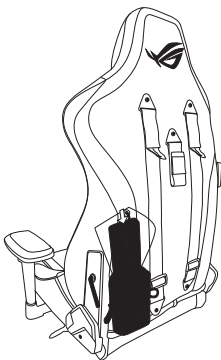

2. Collega il connettore USB di tipo A al power bank.

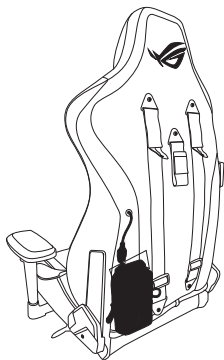

3. La tasca è installata alla sedia con una chiusura in velcro. Puoi rimuoverla facilmente.

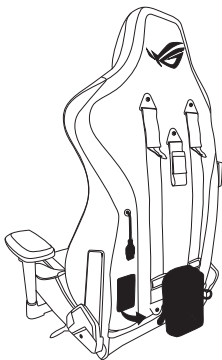

## E Altre funzionalità

a

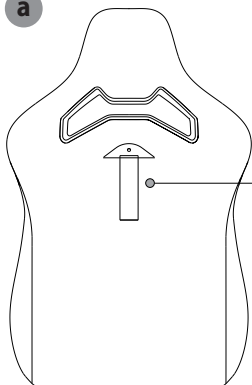

Appendiabiti nella parte posteriore della sedia per appendere borse, vestiti, tazze e altro.

Carico massimo: 2 Kg

Non appendere oggetti più pesanti di 2 Kg.

## b Utilizzo del controller RGB

Potenza: 5V=1A

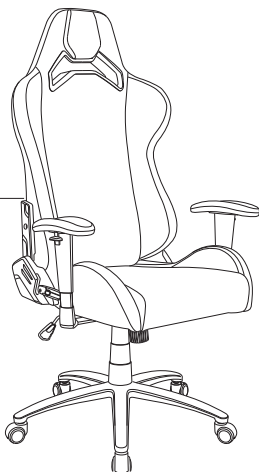
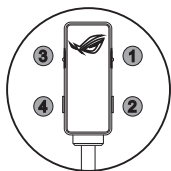

**NON** rimuovere il controller non rimovibile, se lo fai la garanzia non sarà più valida.

## 1. Illuminazione Aura RGB: Accesso / Effetto / Spento

Premi ripetutamente per accendere o spegnere i LED Aura RGB, o per selezionare tra i 7 effetti disponibili: (1) arcobaleno (2) respiro (3) ciclo colore (4) onda (5) Yo-yo luminoso (6) stroboscopico (7) statico.

Premi il pulsante Illuminazione Aura RGB per 3 secondi per spegnere l'illuminazione.

Premi nuovamente per riattivare l'illuminazione, o riconnetti il power bank per mantenere le impostazioni.

**NOTA:** Il power bank potrebbe regolare automaticamente l'uscita quando disattivi l'illuminazione. Scollegalo e ricollegalo se osservi che l'illuminazione esterna Aura RGB non riesce a riattivarsi.

## 2. Colore Aura RGB

Premi ripetutamente per passare tra gli 8 colori disponibili: (1) rosso (2) arancione (3) giallo (4) verde (5) blu (6) indaco (7) viola (8) rosa.

**NOTA:** Questa funzione è disponibile per i seguenti effetti Aura RGB: (2) respiro (6) stroboscopico (7) statico.

## 3. Velocità Aura RGB: Lenta / Normale / Veloce

Premi ripetutamente per passare tra le 3 velocità disponibili: (1) Lenta (2) Normale (3) Veloce.

**NOTA:** Questa funzione è disponibile per i seguenti effetti Aura RGB: (1) arcobaleno (2) respiro (3) ciclo colore (4) onda (5) Yo-yo luminoso (6) stroboscopico.

## 4. Luminosità Aura RGB: 50% / 75% / 100%

Tre livelli di luminosità. La luminosità può essere regolata con un tocco per adattarsi alle condizioni ambientali e alle preferenze dell'utente.

## 5. Ripristino delle impostazioni predefinite

Premi contemporaneamente i pulsanti (2) e (4) per ripristinare la sedia alle impostazioni predefinite.

## F Funzioni regolabili

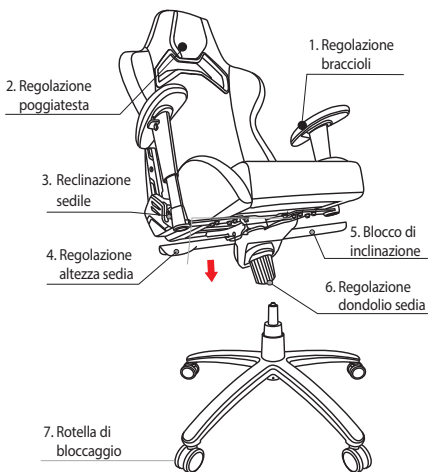

### 1. Regolazione braccioli

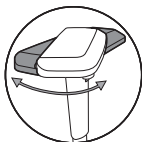

## 2. Regolazione poggiatesta

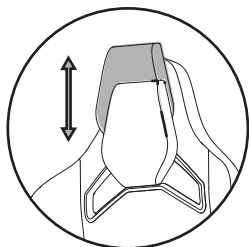

- Regolazione altezza (6 cm)
- Non sollevare il poggiatesta in modo eccessivo.

## 3. Solleva la leva e inclinati lentamente all'indietro.

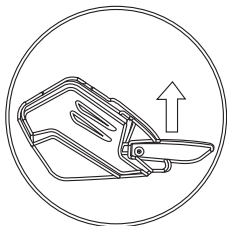

## 4. Regolazione altezza sedia

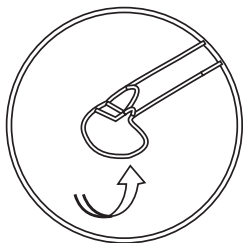

## 5. Blocco/sblocco del meccanismo di inclinazione

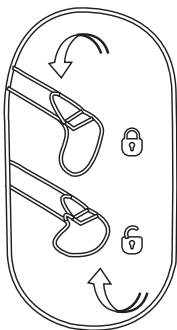

## 6. Regolazione dondolio sedia

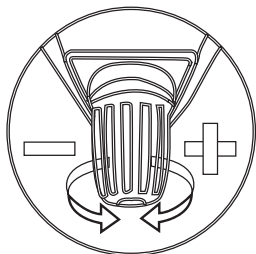

## 7. Rotella di bloccaggio

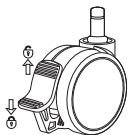



## Правила безопасности



- Сядьте в центр кресла спиной к спинке.



- Не садитесь на край кресла.



- Не вставайте на кресло.



- Не надавливайте откидывающуюся спинку, когда на ней находится человек.



- Остерегайтесь откидного механизма, которые может травмировать ваши руки и пальцы.

## ВНИМАНИЕ!

1. Это кресло должно использоваться только по прямому назначению и надлежащим образом. Мы не несем ответственности за любой ущерб, причиненный в результате неправильной сборки и/или использования.
2. Максимальная рекомендуемая нагрузка – 120 кг.
3. Собирайте и разбирайте кресло надлежащим образом.
4. В целях защиты кожного покрытия не подвергайте кресло воздействию прямых солнечных лучей.
5. Пожалуйста, будьте осторожны при возврате спинки кресла из наклонного положения в исходное состояние.
6. Во избежание повреждения кресла, не прилагайте чрезмерных усилий для поднятия подголовника.
7. Не пытайтесь открыть и трогать модуль индикаторов, поскольку это приведет к аннулированию гарантии.
8. Номинальная потребляемая мощность для этого продукта составляет 5 В / 1 А. Не используйте блок питания с выходной мощностью более 5 В / 3 А.

## A Комплект поставки

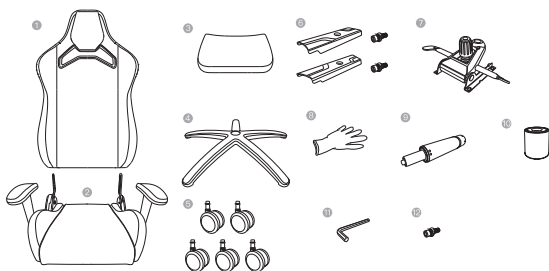

1.	Спинка кресла	5.	Колеса	9.	Газпатрон (газлифт)
2.	Основание сиденья	6.	Боковые крышки с болтами	10.	Кожух для газпатрона
3.	Поясничная подушка	7.	Механизм качания	11.	Шестигранный ключ
4.	Крестовина	8.	Перчатки	12.	Запасной болт

**ПРИМЕЧАНИЕ:** Иллюстрации в этом разделе приведены только для справки.

## **В** Сборка кресла

Пожалуйста, наденьте перчатки перед сборкой.

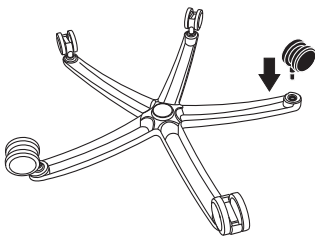

- 1 Вставьте одно за другим колеса в крестовину.

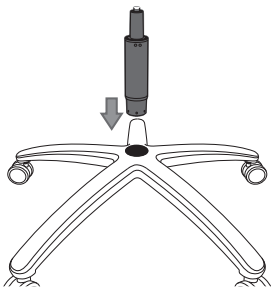

- 2 Вставьте газпатрон в центральное отверстие крестовины, предварительно сняв красный защитный колпачок.

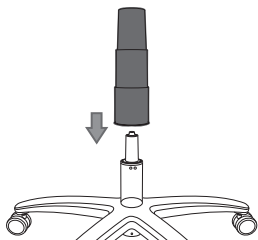

- 3 Поместите кожу на верхнюю часть газпатрона.

Подлокотники ставятся на любую сторону, если не указано иначе.

Пропустите этот шаг для моделей с предварительно собранным подлокотником.

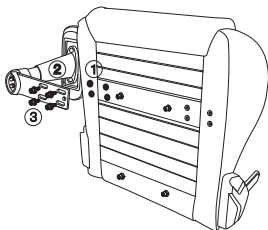

- 4 Снимите предварительно установленные болты и шайбы (1 & 3). Установите 4 больших шайбы (1) между монтажной планкой подлокотника (2) и основанием сиденья. Установите подлокотник на место, затем вставьте и затяните все 4 болта (3). Для затягивания болтов используйте шестигранный ключ. Повторите действия на другой стороне.

- 5 Используйте шестигранный ключ для извлечения из спинки предварительно установленных болтов и шайб.

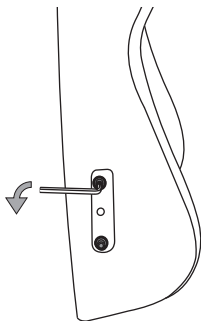

- 6 Снимите защитную упаковку из пенопласта с кронштейнов основания сиденья. Затем осторожно расположите спинку между кронштейнами. Вставьте 4 болта (по 2 с каждой стороны), извлеченных на шаге 5. Затяните их шестигранным ключом. Начните с двух верхних болтов на каждой стороне, затем затяните два нижних болта.

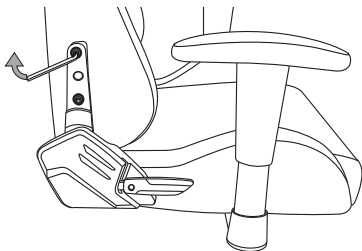

- 7 Установите боковые крышки и затяните болты. (Каждая крышка промаркирована L - для левой стороны и R - для правой.)

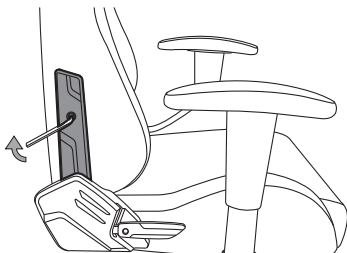

- 8 Переверните кресло сидением вниз. Затем снимите 4 болта с шайбами, установленными на нижней стороне кресла.

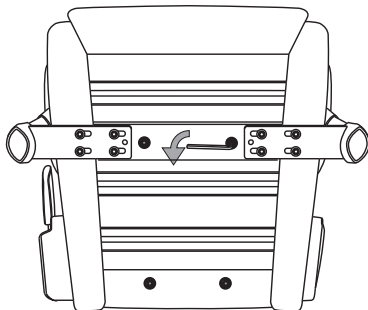

- 9 Повторите описанные выше инструкции для установки механизма качания, затем поместите гайку для установки газпатрона (газлифта), обращенную к спинке сиденья.

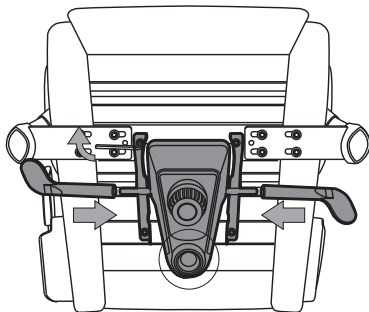

- 10 Вставьте верхнюю часть газпатрона в монтажное отверстие механизма качания, затем поверните кресло в вертикальной плоскости. (Требуется два человека в целях безопасности).

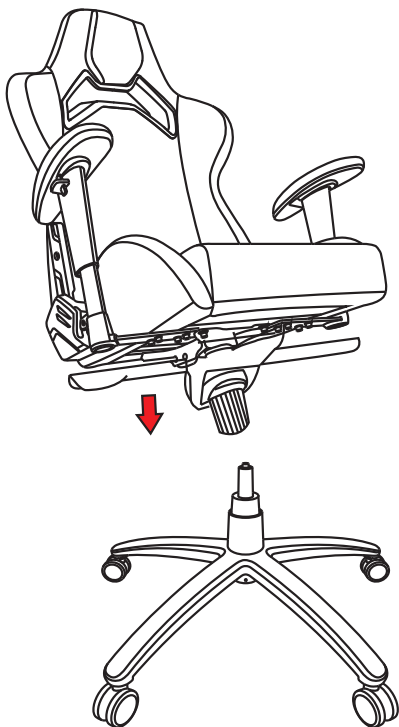

## **C** Подсветка кресла

1. Поместите внешний аккумулятор в карман на обратной стороне спинки кресла.

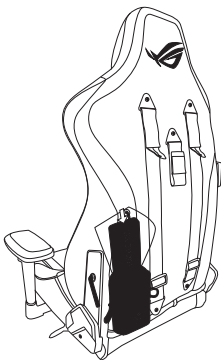

2. Подключите разъем USB Type-A к внешнему аккумулятору.

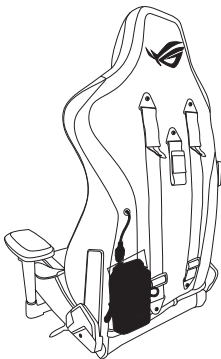

3. Карман крепится к креслу с помощью липучек. Его можно снять.

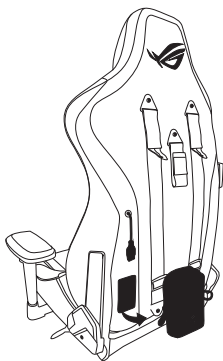



## D Другие функции

a

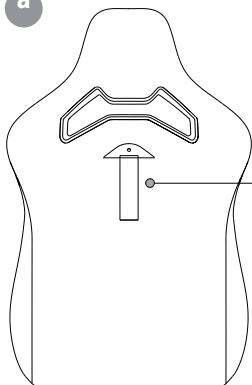

Вешалка на спинке кресла для сумок, одежды и прочего.

Максимальная нагрузка: 2 кг

Пожалуйста, не вешайте предметы весом более 2 кг.

## b Использование контроллера RGB

Напряжение: 5 В = 1 А

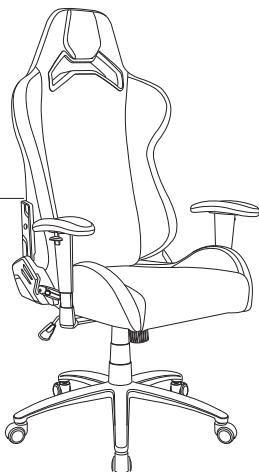
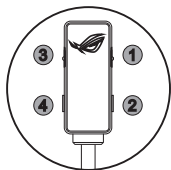

Не пытайтесь снять несъемный контроллер, поскольку это приведет к аннулированию гарантии.

- 1. Подсветка AURA RGB: Включение/отключение/эффект**

Нажмите для включения/отключения AURA RGB или переключения между имеющимися 7 эффектами: (1) радуга (2) дыхание (3) цветовой цикл (4) волна (5) светящийся йо-йо (6) стробирование (7) статический

Для отключения подсветки нажмите и удерживайте кнопку подсветки AURA RGB в течение 3 секунд.

Нажмите для включения или подключите внешний аккумулятор для сохранения прежних настроек.

**ПРИМЕЧАНИЕ:** Внешний аккумулятор может автоматически настроить свою мощность при выключении подсветки. Отключите и снова подключите его, если подсветка AURA RGB не загорелась после повторного включения.
- 2. Цвет AURA RGB**

Нажмите для выбора одного из следующих 8 цветов: (1) красный (2) оранжевый (3) желтый (4) зеленый (5) синий (6) индиго (7) фиолетовый (8) розовый

**ПРИМЕЧАНИЕ:** Эта функция доступна только для следующих эффектов AURA RGB: (2) дыхание (6) стробирование (7) статический
- 3. Скорость AURA RGB: медленная / средняя / быстрая**

Нажмите для выбора одной из следующих 3 скоростей: (1) Медленная (2) Средняя (3) Быстрая

**ПРИМЕЧАНИЕ:** Эта функция доступна только для следующих эффектов AURA RGB: (1) радуга (2) дыхание (3) цветовой цикл (4) волна (5) светящийся йо-йо (6) стробирование
- 4. Скорость AURA RGB: 50% / 75% / 100%**

Три уровня яркости. Яркость можно переключать простым нажатием для соответствия внешней освещенности и предпочтениям.
- 5. Сброс к заводским настройкам**

Для сброса стула к заводским настройкам одновременно нажмите кнопки (2) и (4).

## **E** Регулировка

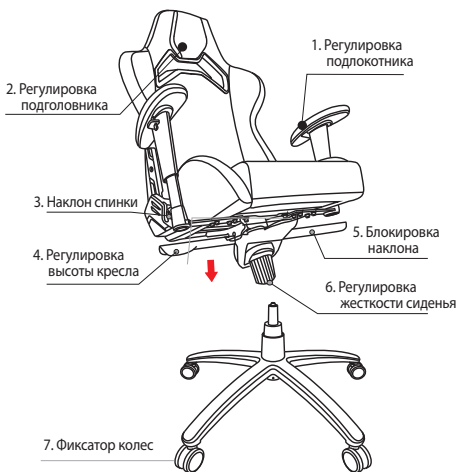

### **1. Регулировка подлокотника**

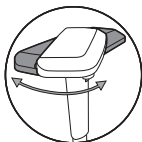

## 2. Регулировка подголовника

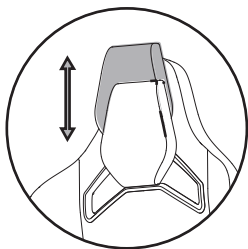

- Регулировка высоты (6 см)
- Пожалуйста не поднимайте высоко подголовник.

## 3. Потяните рычаг вверх и медленно откиньтесь назад.

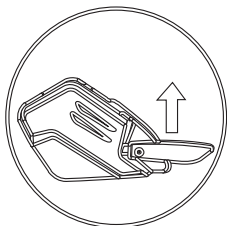

## 4. Регулировка высоты кресла

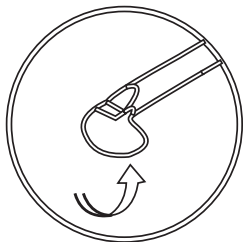

## 5. Блокировка / разблокировка механизма наклона

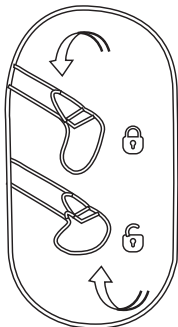

## 6. Регулировка жесткости сиденья

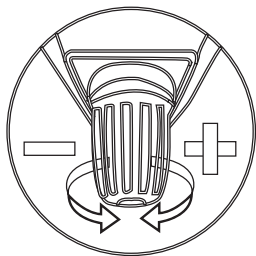

## 7. Фиксатор колес

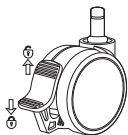

- اجلس وسط الكرسي مع سند الظهر على مسند الظهر.



- لا تجلس على حافة الكرسي.



- لا تقف على الكرسي.



- لا تضغط للأسفل على مسند الظهر المعد للاتكاء عندما يكون هناك شخص جالساً على الكرسي.



- ابقِ يديك وأصابعك بعيدةً عن آلية الاتكاء.



## حذير!

1. يجب استخدام هذا الكرسي بطريقة طبيعية غير تعسفية. نحن غير مسؤولين عن أي تلفيات تنتج من التركيب و/أو الاستخدام غير المناسب للمنتج.
2. الحد الأقصى الموصى به للوزن المحمول هو 120 كجم (264.0 باوند).
3. لا تركيب أو تفك الكرسي مطلقاً بطريقة غير صحيحة.
4. يرجى إبقاء الكرسي بعيداً عن أشعة الشمس المباشرة للحفاظ على جلده.
5. يرجى الانتباه لظهرك عندما يعود مسند الظهر من وضع الاتكاء لوضعه الطبيعي.
6. لتفادي تلف الكرسي؛ يرجى عدم رفع مسند الرأس لأعلى بعنف.
7. لا تحاول مطلقاً فتح وحدة LED ولمسها لأن ذلك سييطل الضمان.
8. جهد دخل الطاقة لهذا المنتج هو 5 فولت/1 أمبير. لا تستخدم مهايئ طاقة بخرج يفوق 5 فولت/3 أمبير.

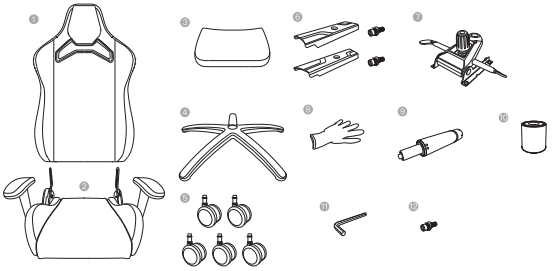

الإسطوانة الرافعة الهيدروليكية	9.	العجلات	5.	مسند الظهر	1.
الغطاء لامتداحل	10.	أغطية جانبية ببراغي	6.	قاعدة المقعد	2.
المفتاح السداسي	11.	وحدة التحكم	7.	وسادة أسفل الظهر	3.
البرغي الاحتياطي	12.	القفازات	8.	قاعدة العجلة	4.

ملاحظة: الصور التوضيحية معروضة كمرجع فقط وقد تختلف عن الكرسي الفعلي من حيث المظهر والخواص.

## B تركيب الكرسي

ضع القفازات قبل التركيب.

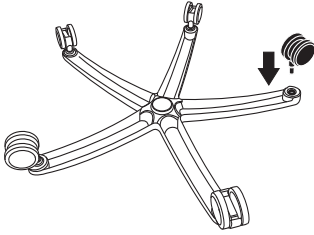

1 أدخل العجلات واحدة تلو الأخرى وادفعها بالقاعدة.

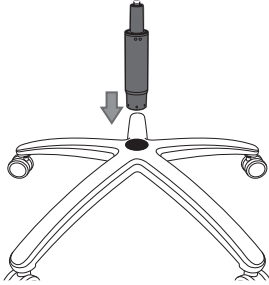

2 أدخل الإسطوانة الرافعة الهيدروليكية بالفتحة المركزية الموجودة بالقاعدة. أزل الغطاء الواقي الأحمر الموجود على القمة إذا كان موجوداً.

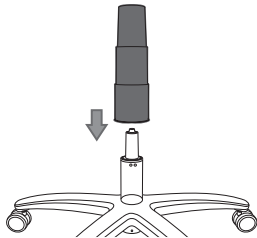

3 ضع الغطاء المتداخل أعلى الإسطوانة الرافعة الهيدروليكية.



مساند الأذرع لا ترتبط بجوانب معينة ما لم يُحدّد غير ذلك.

بالنسبة للطرز ذات مساند الأذرع المسبقة التركيب، يرجى تخطي هذه الخطوة.

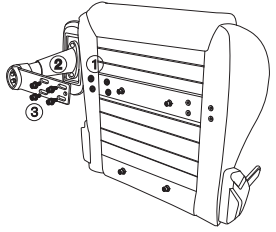

4 أزل البراغي والحلقات المركبة مسبقاً (1 & 3). ضع الحلقات الكبيرة الـ 4 (1) بين شريط تثبيت مسند الذراع (2) وقاعدة المقعد. ارفع مسند الذراع في مكانه، ثم أدخل البراغي الـ 4 كلها واربطها (3). استخدم المفتاح السداسي لربطهم جميعاً، وكرر نفس الخطوة على الجانب الآخر.

5 استخدم المفتاح السداسي لإزالة البراغي والحلقات المركبة مسبقاً من مسند الظهر.

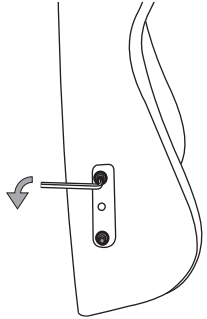

6 أزل الأغطية الرخوة الواقية من مساند الظهر الخاصة بقاعدة المقعد. ثم ضع مسند الظهر بحرص بين الدعامات. أدخل البراغي الـ 4 (2 على كل جانب) التي قمت بإزالتها في الخطوة رقم 5 واربطها باليد أولاً. ثم استخدم المفتاح السداسي لربطها. ابدأ بالبرغيين العلويين بكل جانب، ثم السفليين.

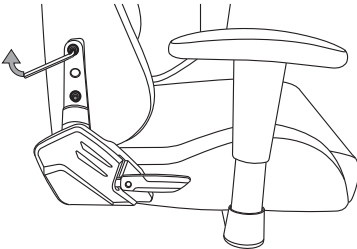

7 ركب الأغطية الجانبية واربط البراغي. (الأغطية معلمة بـ "L" للجانب الأيسر و"R" للأيمن من الداخل).

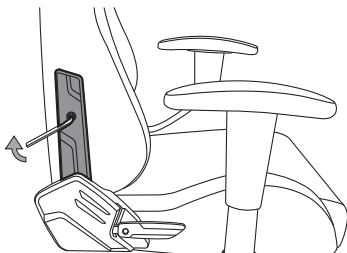

8 والأن اقلب الكرسي واجعله متجهًا للأسفل. ثم أزل البراغي الـ 4 المسبق تثبيتها من الجانب السفلي مع الحلقات.

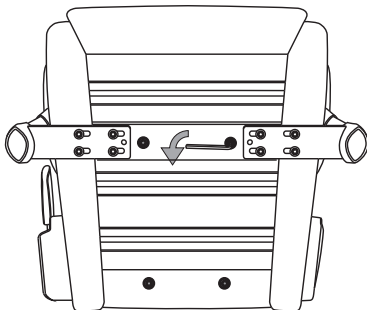

9 كرر الخطوة أعلاه لتركيب وحدة التحكم، ثم ضع الصامولة لتثبيت الإسطوانة الرافعة الهيدروليكية المواجهة لخلفية المقعد (حيث تم تثبيت مسند الظهر).

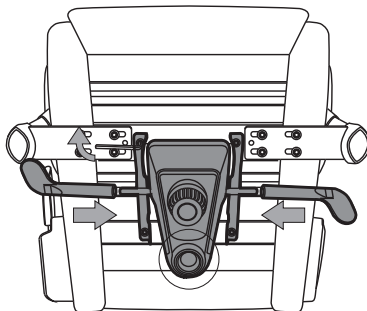

أدخل الجزء العلوي من الإسطوانة الرافعة الهيدروليكية بفتحة التثبيت الموجودة بوحدة التحكم، ثم اقلب الكرسي في وضع مستقيم. (مطلوب شخصين للتركيب من أجل سلامتك)

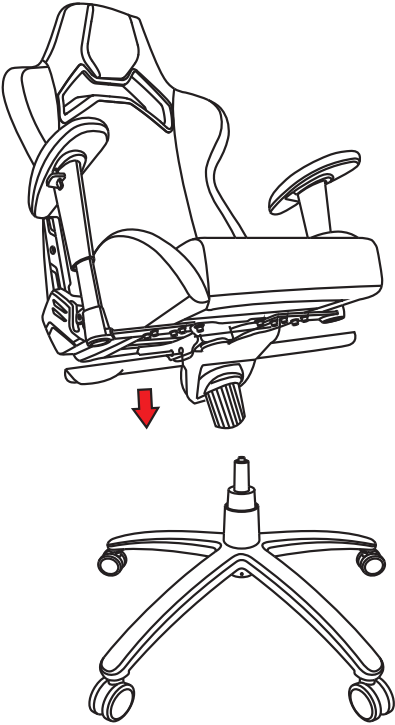

1. ضع بنك الطاقة بالجيب الموجود خلف الكرسي.

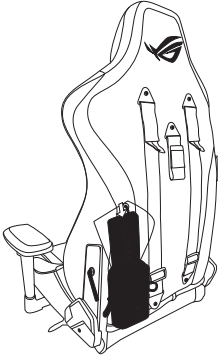

2. قم بتوصيل موصل USB من الفتحة A بنبك الطاقة.

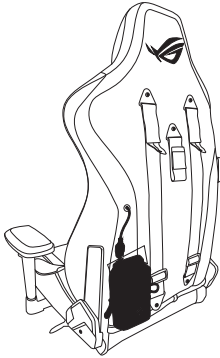

3. الجيب متصل بالكروسي بواسطة مشبك خطافي. يمكنك إزالة المشبك بسهولة ونزعه.

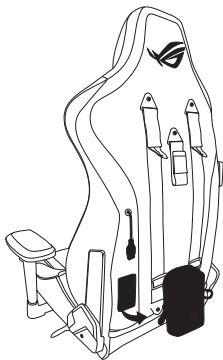

هناك حمالة بظهر الكرسي لتعليق حقائبك وملابسك والكؤوس وغيرها الكثير.  
الحد الأقصى للحمل: 2 كجم  
يرجى عدم تعليق أشياء يفوق وزنها 2 كجم.

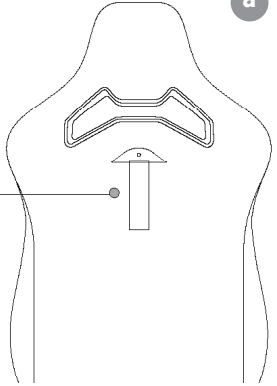

استخدام متحكم RGB

الجهد الكهربائي: 5 فولت 1 أمبير

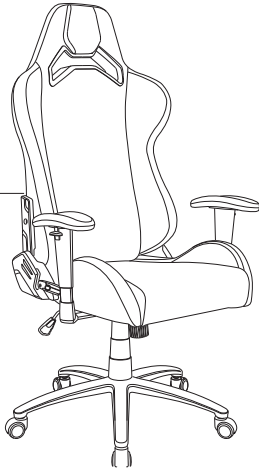
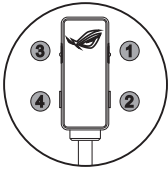

لا تزل المتحكم الغير قابل للفصل لأن ذلك سيطل الضمان.

1. إضاءة AURA RGB: تشغيل / تأخير / إيقاف

اضغط بشكل متكرر لتشغيل أو وقف تشغيل مؤشرات Aura RGB LED, أو للتنقل بين المؤثرات الـ 7 الحالية: (1) قوس قزح (2) الوامض (3) اللون الدائرة (4) متموج (5) Yo-Yo متوهج (6) وامض (7) ثابت  
اضغط على زر إضاءة Aura RGB لمدة 3 ثوانٍ بوقف الإضاءة.  
اضغط على الزر لتنشيطها مرة أخرى أو إعادة توصيل بنك الطاقة سيحفظ الإضاءة على الإعداد السابق.

**ملاحظات:** قد يضبط بنك الطاقة تلقائيًا الخرج الخاص به عندما تتوقف الإضاءة. افصل بنك الطاقة وأعد توصيله إذا تعذر تنشيط إضاءة Aura RGB بعد إعادة التشغيل.

2. لون AURA RGB

اضغط بشكل متكرر للتنقل بين الألوان الجذابة الـ 8 التالية: (1) أحمر (2) البرتقالي (3) أصفر (4) أخضر (5) أزرق (6) النيلي (7) بنفسجي (8) زهري

**ملاحظات:** هذه الميزة متاحة فقط في مؤثرات Aura RGB التالية - (2) الوامض (6) وامض (7) ثابت.

3. سرعة AURA RGB: بطيئة / متوسطة / سريعة

اضغط بشكل متكرر للتنقل بين سرعات تأثير الألوان الـ 3 التالية: (1) بطيئة (2) متوسطة (3) سريعة.

**ملاحظات:** هذه الميزة متاحة فقط في مؤثرات Aura RGB التالية - (1) قوس قزح (2) الوامض (3) اللون الدائرة (4) متموج (5) Yo-Yo متوهج (6) وامض.

4. سطوع AURA RGB: 50% / 75% / 100%

ثلاثة مستويات للسطوع. يمكن تبديل درجة السطوع من خلال نفرة بسيطة لتلائم إضاءة البيئة المحيطة وما تفضله.

5. إعادة الضبط على وضع المصنع

اضغط على زر (2) وزر (4) معًا لإعادة ضبط الكرسي على إعدادات المصنع الافتراضية.

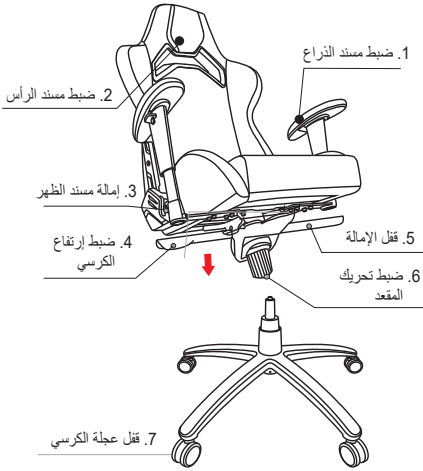

## 1. ضبط مسند الذراع

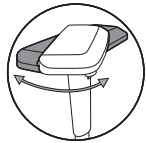



3. اسحب الذراع لأعلى أمله  
للخلف ببطء

2. ضبط مسند الرأس

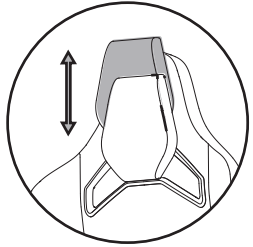
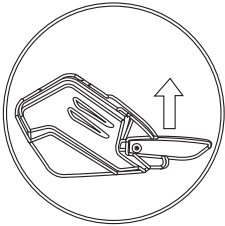

- ضبط الارتفاع (6 سم)
- يرجى عدم المبالغة في رفع مسند الرأس.

5. قفل/إلغاء قفل آلية الإمالة

4. ضبط ارتفاع الكرسي

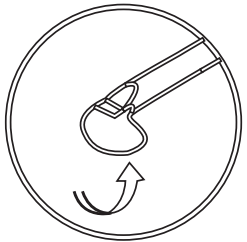
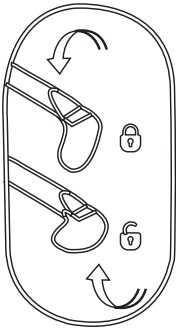

## 6. ضبط تحريك المقعد

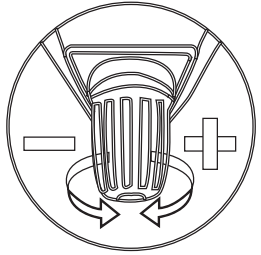

## 7. قفل عجلة الكرسي

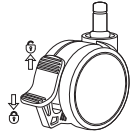

## Poznámky k bezpečnosti



- Posadte se doprostřed židle tak, aby vaše záda spočívala na opěráku.



- Nesedejte na okraj židle.



- Nestoupejte na židli.



- Netlačte na sklopený opěrák, když na židli někdo sedí.



- Udržujte své ruce a prsty v bezpečné vzdálenosti od mechanismu sklápění.

## VAROVÁNÍ!

1. Tuto židli je dovoleno používat normálním, nikoli hrubým způsobem. Neneseme odpovědnost za žádné škody způsobené nesprávným sestavením a/nebo používáním.
2. Maximální doporučené zatížení je 120 kg (264,5 liber).
3. V žádném případě nesestavujte ani nedemontujte tuto židli nesprávným způsobem.
4. Uchovávejte tuto židli mimo dosah přímého slunečního záření, aby byly chráněny kožené části.
5. Při vracení opěráku ze sklopené do normální polohy si hlídejte záda.
6. Aby se zabránilo poškození židle, při vysouvání opěrky hlavy nepoužívejte nadměrnou sílu.
7. V žádném případě nezkoušejte otevřít a dotýkat se LED modulu; v opačném případě dojde k propadnutí záruky.
8. Jmenovitý příkon tohoto výrobku je 5 V / 1 A. Nepoužívejte napájecí adaptér s výstupem překračujícím 5 V / 3 A.

## A Obsah krabice

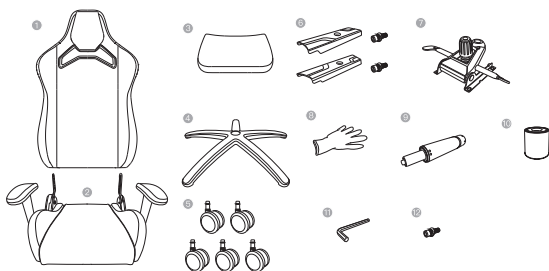

1.	Opěrák	5.	Kolečka	9.	Válec hydraulického zvedání
2.	Základna židle	6.	Boční kryty s šrouby	10.	Teleskopický kryt
3.	Bederní polstr	7.	Ovládací jednotka	11.	Šestihranný INBUS klíč
4.	Základna s kolečky	8.	Rukavice	12.	Náhradní šroub

**Poznámka:** Obrázky jsou pouze popisné. Skutečný vzhled a vlastnosti vaší židle se mohou lišit.

## B Sestavení židle

Před sestavením si nasadte rukavice.

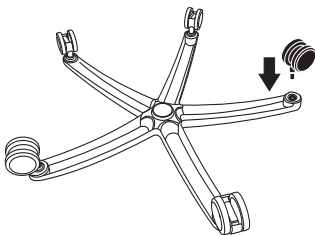

- 1 Postupně nasadte a zatlačte kolečka do základny.

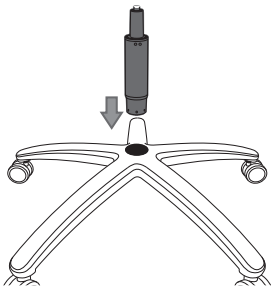

- 2 Zasuňte válec hydraulického zvedání do středového otvoru základny. Sejměte červenou ochrannou krytku z horní části (pokud je nasazená).

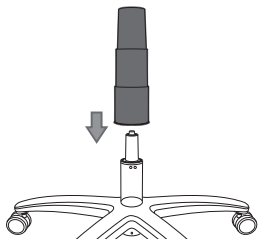

- 3 Nasadte teleskopický kryt na horní část válce hydraulického zvedání.

Není-li označeno jinak, područky jsou oboustranné.

U modelů, které jsou dodávány s předinstalovanými područkami, tento krok vynechte.

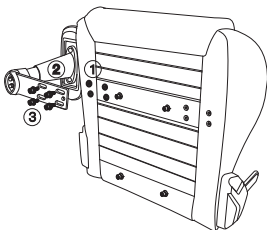

- 4 Odmontujte předinstalované šrouby a podložky (1) a (3). Umístěte 4 velké podložky (1) mezi montážní osu područky (2) a základnu židle. Přidržte područku na místě a potom zasuňte a utáhněte všechny 4 šrouby (3). Všechny šrouby utáhněte šestihřanným klíčem. Postup zopakujte na opačné straně.

- 5 S použitím šestihřanného klíče odmontujte předinstalované šrouby a podložky z opěráku.

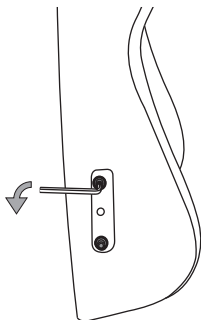

- 6 Odstraňte ochranné pěnové kryty z držáků základny židle. Potom umístěte opěrák opatrně mezi držáky. Vložte a rukou zašroubujte 4 šrouby (2 na každé straně), které jste demontovali v kroku 5. Potom je utáhněte šestihřanným klíčem. Začněte dvěma šrouby na každé straně nahoře a potom pokračujte dvěma dolními.

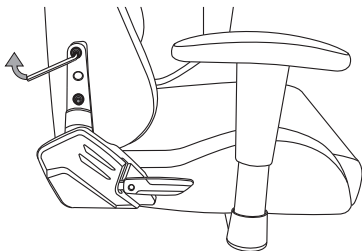

- 7 Nasadíte boční kryty a utáhnete šrouby. (Kryty jsou uvnitř označeny „L“ pro levou stranu a „R“ pro pravou stranu.)

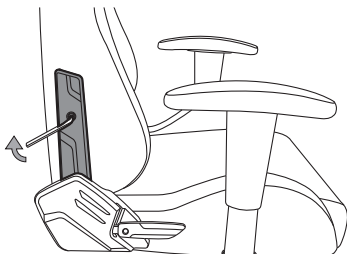

- 8 Nyní otočte židli vzhůru nohama. Potom odmontujte 4 předinstalované šrouby ze spodní strany s podložkami.

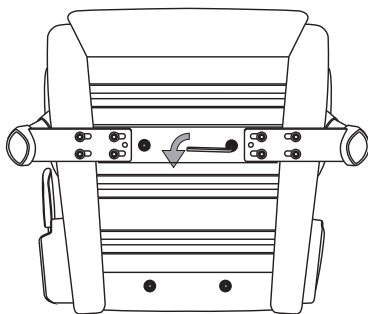

- 9 Zopakováním výše uvedeného kroku namontujte ovládací jednotku a potom umístěte matici pro upevnění válce hydraulického zvedání směrem k zadní straně židle (kde je nainstalován opěrák).

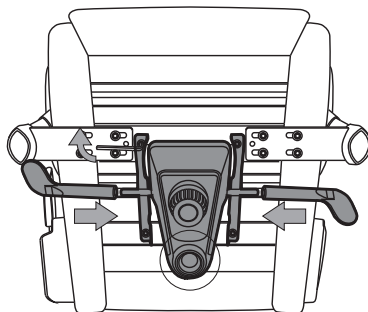

- 10 Zasuňte horní stranu válce hydraulického zvedání do montážního otvoru na ovládací jednotce a potom otočte židli do vzpřímené polohy. (Pro zajištění bezpečnosti je třeba, aby tuto operaci provedly dvě osoby)

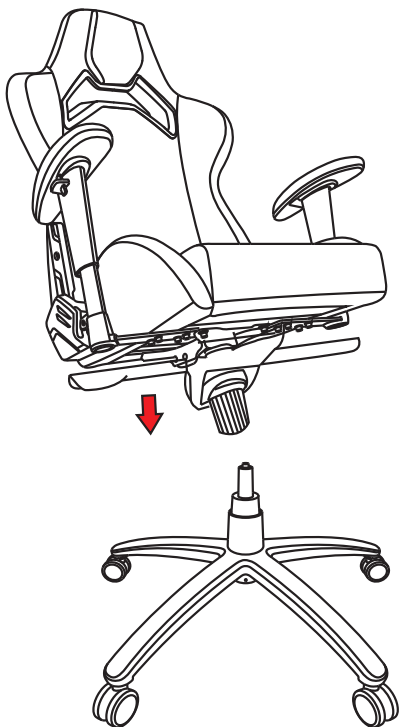



## Osvětlení židle

1. Vložte powerbanku do pouzdra na zadní straně židle.

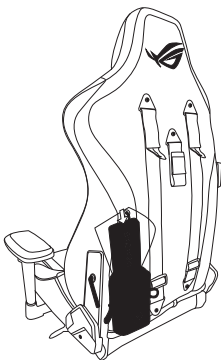

2. Připojte k powerbance konektor USB Type-A.

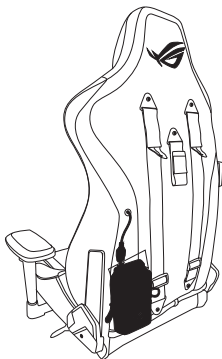

3. Pouzdro je upevněno k židli suchým zipem. Můžete jej jednoduše sundat a odnést.

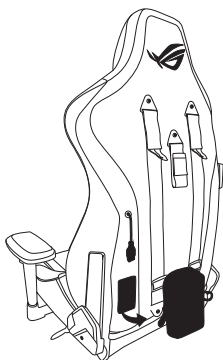

## D Další vlastnosti

a

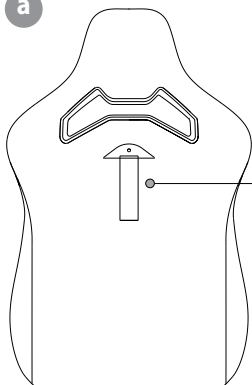

Věšák na zadní straně židle slouží k pověšení zavazadel, oděvů, šálek atd.  
Maximální nosnost: 2 kg  
Nezavěšujte předměty těžší než 2 kg.

## b Používání ovladače RGB

Charakteristika: 5V=1A

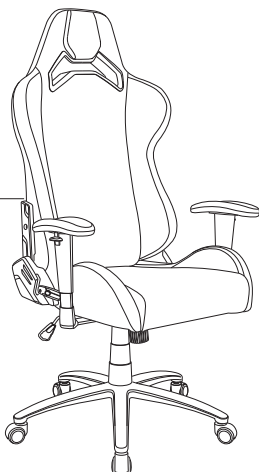
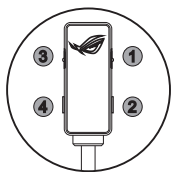

NEVYJÍMEJTE pevně zabudovaný ovladač; v opačném případě dojde k propadnutí záruky.

1. Osvětlení Aura RGB: zapnuto / efekt / vypnuto

Opakovaným stisknutím zapnete nebo vypnete LED osvětlení Aura RGB nebo přepnete mezi 7 různými efekty: (1) Duha (2) Impulzy (3) Cyklus barev (4) Vlna (5) Svítící jo-jo (6) Stroboskop (7) Statický

Stisknutím tlačítka osvětlení Aura RGB na 3 sekundy osvětlení vypnete.

Dalším stisknutím jej znovu zapnete. Při opakovaném připojení powerbanky bude uchováno předchozí nastavení.

**POZNÁMKA:** Po vypnutí osvětlení může vaše powerbanka automaticky přizpůsobit svůj výstup. Pokud osvětlení Aura RGB nelze po zapnutí znovu obnovit, odpojte a znovu připojte powerbanku.

2. Barva osvětlení Aura RGB

Opakovaným stisknutím procházejte následujícími 8 úžasnými barvami: ((1) červená (2) oranžový (3) žlutá (4) zelená (5) modrá (6) Indigo (7) fialová (8) růžová

**POZNÁMKA:** Tato funkce je k dispozici pouze pro následující efekty Aura RGB - (2) impulzy (6) stroboskop (7) statický

3. Rychlost osvětlení Aura RGB: pomalé / střední / rychlé

Opakovaným stisknutím přepnete mezi následujícími 3 rychlostmi barevných efektů: (1) pomalé (2) střední (3) rychlé

**POZNÁMKA:** Tato funkce je k dispozici pouze pro následující efekty Aura RGB - (1) Duha (2) Impulzy (3) Cyklus barev (4) Vlna (5) Svítící jo-jo (6) Stroboskop

4. Jas osvětlení Aura RGB: 50% / 75% / 100%

Tři úrovně jasu. Jas lze jednoduchým klepnutím přepnout tak, aby odpovídal prostředí a požadavkům.

5. Obnova továrního režimu

Současným stisknutím tlačítka (2) a tlačítka (4) obnovíte výchozí nastavení židle.

## E Nastavitelné funkce

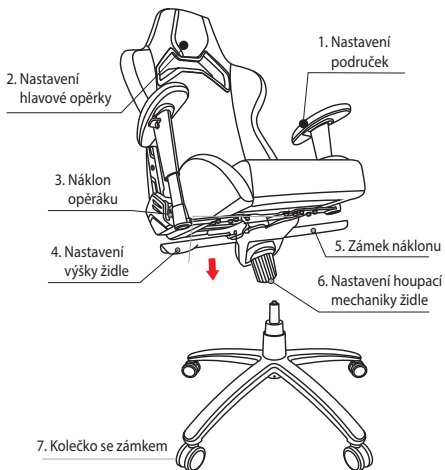

### 1. Nastavení područek

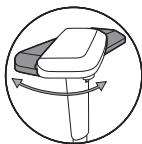

## 2. Nastavení hlavové opěrky

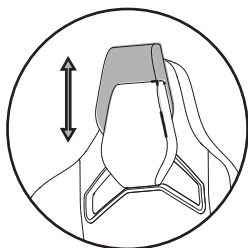

- Nastavení výšky (6 cm)
- Při vysouvání opěrky hlavy nepoužívejte nadměrnou sílu.

## 3. Zvedněte páčku a pomalu se zakloňte.

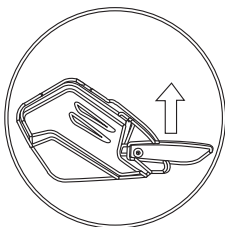

## 4. Nastavení výšky židle

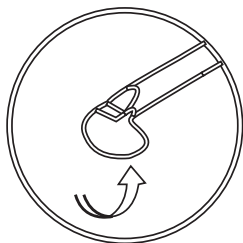

## 5. Zamknutí/odemknutí mechanismu náklonu

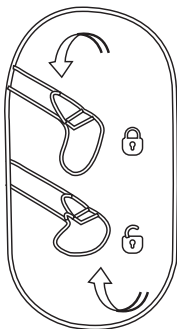

## 6. Nastavení houpací mechaniky židle

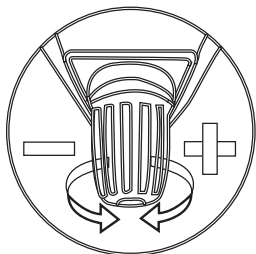

## 7. Kolečko se zámek

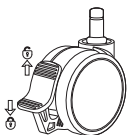

- שב במרכז הכיסא כאשר גבך נשען על משענת הגב.

- אל תשב בשולי הכיסא.

- אל תעמוד על הכיסא.

- אל תדחוף את משענת הגב מטה כשהיא במצב התחתון וכאשר מישהו יושב על הכיסא.



- הרחק את ידיך ואת אצבעותיך ממנגנון ההטיה.



## אזהרה!

1. יש להשתמש בכיסא זה אך ורק על פי אופן השימוש הרגיל שלו, וללא שימוש לרעה. החברה לא תישא באחריות לכל נזק הנובע מהרכבה ו/או משימוש שאינם תקינים.
2. המשקל המרבי המומלץ הוא 120 ק"ג (265.5 פאונד).
3. לעולם אל תרכיב ואל תפרק את הכיסא באופן שאינו הולם.
4. הרחק את הכיסא מאור שמש ישיר כדי לשמור על חלקי העור שלו.
5. היזהר כאשר משענת הגב חוזרת למצבה המקורי ממצב שוכב.
6. למניעת נזק לכיסא, אין להפעיל כוח רב כדי למשוך את משענת הראש.
7. לעולם אל תנסה לפתוח ולגעת במודול ה-LED, דבר זה יגרום לפקיעת האחריות.
8. דירוג הכניסה במוצר זה הוא 5V/1A. אין להשתמש בספק כוח עם מוצא שעולה על 5V/3A.

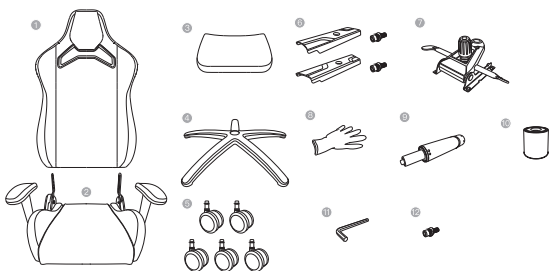



1.	משענת גב	5.	גלגלים	9.	בוכנה הידראולית
2.	בסיס המושב	6.	כיסויי צד עם ברגים	10.	כיסויי טלסקופי
3.	כרית מותניים	7.	יחידת בקרה	11.	מפתח משושה
4.	בסיס גלגלים	8.	כפפות	12.	בורג רזרבי

**הערה:** |תרשימים קיימים לצורך התייחסות בלבד והמראה והתכונות שבהם עשויים להיות שונים מהכיסא שברשותך.

## הרכבת הכיסא

B

לפני ההתקנה, הרכב כפפות.

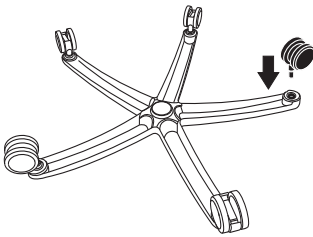

1 הכנס ודחף את הגלגלים אל תוך הבסיס, אחד אחרי השני.

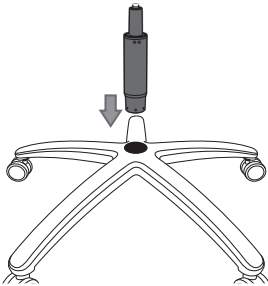

2 הכנס את הבוכנה ההידראולית לפתח המרכזי של הבסיס. שלוף את מכסה המגן האדום שבחלק העליון, אם ישנו.

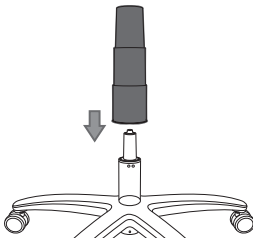

3 הנח את הכיסוי הטלסקופי על החלק העליון של הבוכנה ההידראולית.

לרוב, אין הבדל בין שתי משענות הזרוע  
וניתן להרכיב אותן בכל אחד משני הצדדים  
אלא אם ישנה תווית המורה אחרת.

בדגמים בהם משענת הזרוע מורכבת  
מראש, יש לדלג על שלב זה.

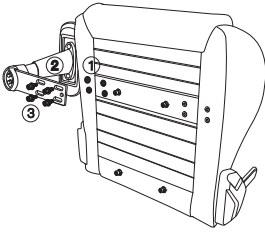

4 הסר את הברגים והדסקיות שהורכבו מראש (1 ו-3). הנח את 4 הדסקיות הגדולות (1) בין מוט ההרכבה של משענת הזרוע (2) לבסיס המושב. החזק את משענת הזרוע במקומה, ולאחר מכן הכנס והדק את כל ארבעת הברגים (3). השתמש במפתח המשושה כדי להדק את כל הברגים, וחזור על הפעולה בצד השני.

5 השתמש במפתח המשושה כדי לשלוף את הדסקיות והברגים המורכבים מראש ממשענת הגב.

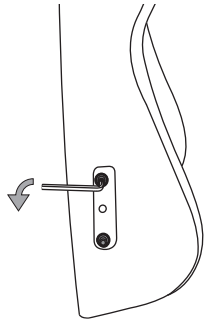

6 הסר את כיסויי המגן מהקצף ממשענת המושב ומבסיס המושב. לאחר מכן, מקם בזהירות את משענת הגב בין התושבות. הכנס וחבר את ארבעת הברגים (2 בכל צד) שהסרת בשלב 5, תחילה באופן ידני. לאחר מכן הדק אותם בעזרת המפתח המשושה. התחל עם שני הברגים בחלק העליון של כל צד, ולאחר מכן המשך עם שני הברגים התחתונים.

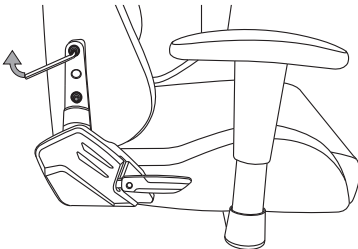

7 התקן את כיסויי הצד והדק את הברגים. (הכיסויים נושאים את הסימון "L" לצד שמאל ו"R" לצד ימין בחלק הפנימי).

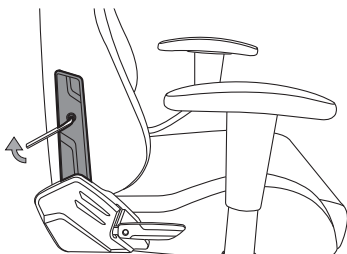

8 כעת הפוך את הכיסא כך שיפנה מטה. לאחר מכן שלוף את ארבעת הברגים המורכבים מראש מהחלק התחתון, יחד עם הדסקיות.

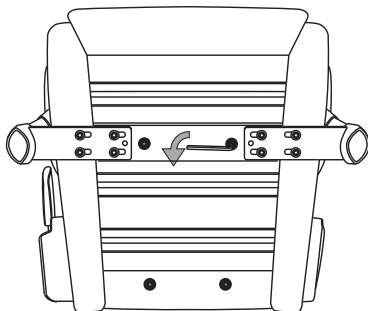

9 חזור על השלב הקודם והתקן את יחידת הבקרה, ולאחר מכן מקם את האום כך שיורכב על הבוכנה ההידראולית כשפניו אל גב הכיסא (המקום בו משענת הגב מותקנת).

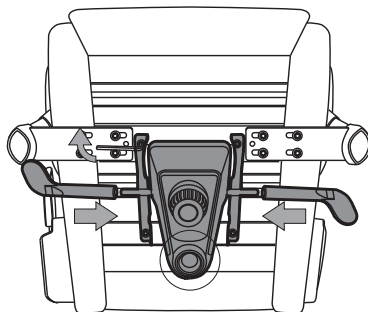

10 הכנס את החלק העליון של הבוכנה ההידראולית אל תוך פתח ההרכבה שביחידת הבקרה, ולאחר מכן הפוך את הכיסא כך שיהיה במצב הרגיל שלו. (למען השמירה על הבטיחות, על שני בני אדם לעשות זאת).

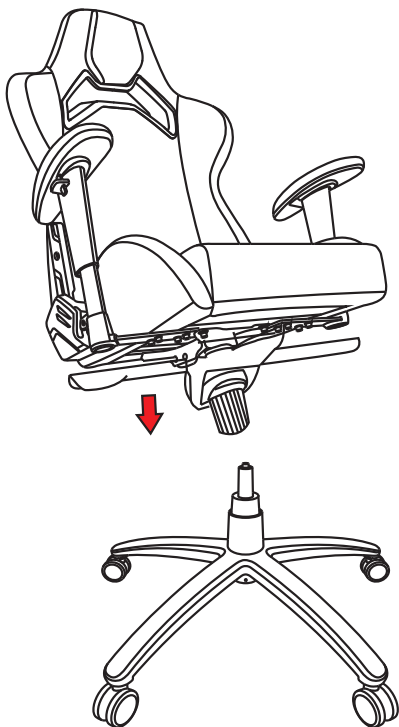

1. מקם את ערכת הסוללות בכיס שבגב הכיסא.

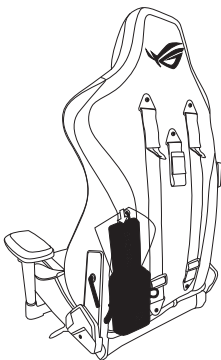

2. חבר את מחבר USB Type-A אל ערכת הסוללות.

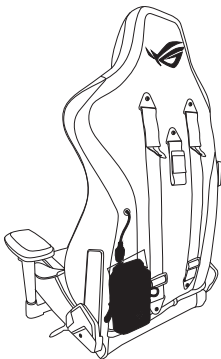

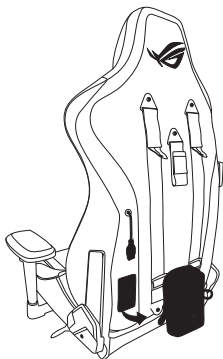

מתלה בחלק האחורי של הכיסא לתליית תיקים, בגדים, ספלים ועוד.  
 עומס מרבי: 2 ק"ג  
 אין לתלות פריטים שמשקלם עולה על 2 ק"ג.

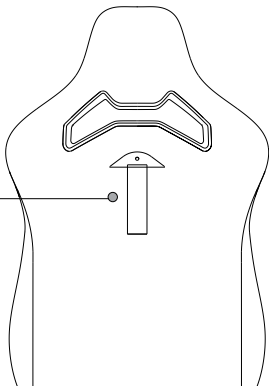

שימוש בבקר RGB

דירוג: 5V -1A

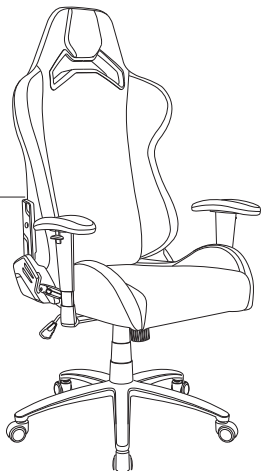
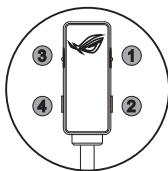

אין לשלוף את הבקר הבלתי נתיק, הדבר יגרום לפקיעת האחריות.



1. תאורת Aura RGB: דולקת / אפקט / כבוייה

לחץ מספר פעמים כדי להדליק ולכבות את נורות Aura RGB LED, או כדי לעבור בין 7 המצבים הבאים: (1) קשת בענן (2) נשימה (3) סבב צבעים (4) גל (5) יויו זוהר (6) משואה (7) דולק קבוע

לחץ על לחצן התאורה של Aura RGB למשך 3 שניות כדי לכבות את התאורה.

לחץ שנית כדי להדליק את התאורה או חבר בחזרה את ערכת הסוללות כדי לשמור על ההגדרה הקודמת.

**הערה:** ייתכן שערכת הסוללות תכוון אוטומטית את המוצא כאשר התאורה תכובה. נתק וחבר אותה מחדש אם לא ניתן להדליק את תאורת Aura RGB לאחר הדלקתה.

2. צבע Aura RGB

לחץ מספר פעמים כדי לעבור בין 8 הצבעים הבאים: (1) אדום (2) כתום (3) צהוב (4) ירוק (5) כחול (6) כחול כהה (אינדיגו) (7) סגול (8) ורוד

**הערה:** תכונה זו זמינה אך ורק במצבי Aura RGB הבאים: (2) נושם (6) משואה (7) דולק קבוע

3. מהירות Aura RGB: איטית / בינונית / מהירה

לחץ מספר פעמים כדי לעבור בין 3 מהירויות הצבעים: (1) איטית (2) בינונית (3) מהירה

**הערה:** תכונה זו זמינה אך ורק במצבי Aura RGB הבאים: (1) קשת בענן (2) נשימה (3) סבב צבעים (4) גל (5) יויו זוהר (6) משואה

4. בהירות תאורת Aura RGB: 50% / 75% / 100%

שלוש רמות בהירות. ניתן לשנות את רמת הבהירות על ידי הקשה פשוטה בהתאם לתאורת הסביבה ולהעדפה.

5. אפס להגדרות ברירת המחדל

לחץ על הלחצן (2) ועל (4) בו זמנית כדי לאפס את הכיסא להגדרות ברירת המחדל שלו.

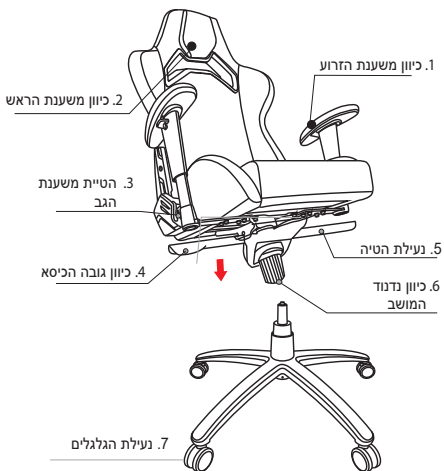

## 1. כיוון משענת הזרוע



2 קדימה ואחורה



1 כיוון גובה



4 פנימה והחוצה

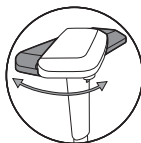

3 כיוון סיבוב

### 3. משוך את הידית והישען אחורה באיטיות.

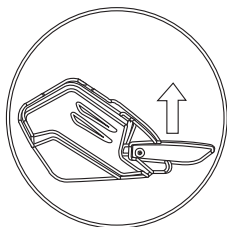

### 2. כיוון משענת הראש

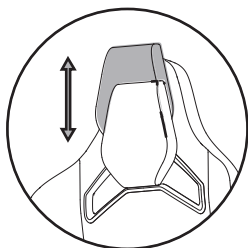

- כיוון גובה (6 ס"מ)
- אין להרים את משענת הראש יתר על המידה.

### 5. נעילה/שחרור של מנגנון ההטיה

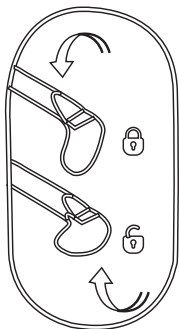

### 4. כיוון גובה הכיסא

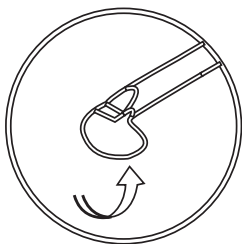

## 6. כיוון נדנוד המושב

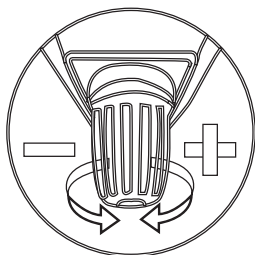

## 7. נעילת הגלגלים

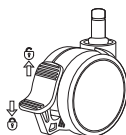

## Biztonsági felhívások



- Üljön a szék közepére, a hátának támaszkodva.



- Ne üljön a szék szélére.



- Ne álljon fel a székre.



- Ne nyomja le a megdöntött támaszt amikor valaki ül rajta.



- Tartsa kezét és ujjait távol a megdöntő mechanizmustól.

## FIGYELMEZTETÉS!

1. A széket csak normál és nem durva módon használja. Nem vagyunk felelősek a nem megfelelő összeszerelésből és/vagy használatból származó károkért.
2. A maximális ajánlott súlyterhelés 120 KG.
3. Soha nem rakja össze vagy ne szedje szét a széket nem megfelelő módon.
4. Kérjük tartsa a széket távol közvetlen napfénytől, hogy védje a bőrt.
5. Kérjük figyeljen a háttára amikor a támasz visszatér az eredeti helyzetbe a döntött helyzetből.
6. A szék károsodását elkerülendő, ne használjon túlzott erőt a fejtámasz felhúzására.
7. Soha ne próbálja meg kinyitni és megérinteni a LED modult, mert ezzel érvénytelenné válik a garancia.
8. A termék névleges tápfeszültség bemenete 5V/1A. Ne használjon olyan tápadaptert amelynek a kimenete meghaladja 5V/3A.

## A

## A csomag tartalma

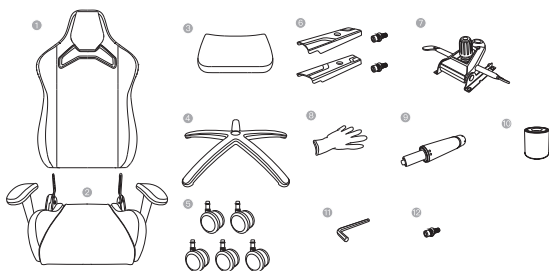

1.	Háttámla	5.	Kerekek	9.	Hidraulikus emelőhenger
2.	Ülésalap	6.	Oldalsó burkolatok csavarokkal	10.	Teleszkópos burkolat
3.	Gerincpárna	7.	Vezérlőegység	11.	Hatlapfejű csavarkulcs
4.	Kerékalap	8.	Kesztyűk	12.	Tartalék csavar

**Megjegyzés:** Az ábrák csak illusztrációs célt szolgálnak, és a szék tényleges megjelenése, illetve funkciói eltérőek lehetnek.

## B A szék összeszerelése

Összeszerelés előtt vegye fel a kesztyűt.

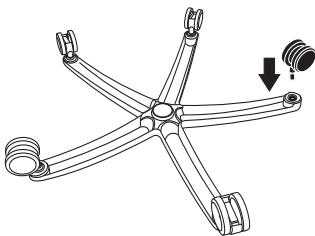

- 1 Illessze be egyenként a kerekeket az alapba.

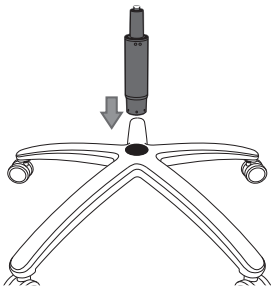

- 2 Helyezze be a hidraulikus emelőhengert az alap középső nyílásába. Távolítsa el a piros védősapkát felülről (ha van).

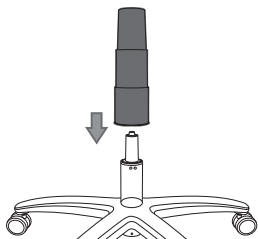

- 3 Helyezze a teleszkópos burkolatot a hidraulikus emelőhengert tetejére.

A kartámaszokon az oldalsó panelek általában egyformák, kivéve, ha másképp vannak felcímkézve.

Ha az adott székre már gyárilag fel vannak szerelve a kartámaszok, akkor hagyja ki ezt a lépést.

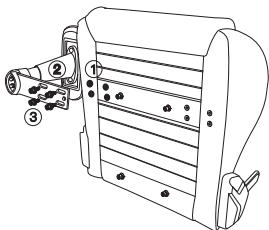

- 4 Távolítsa el a gyárilag behelyezett csavarokat és betéteket (1 és 3). Helyezze a négy nagy méretű betétet (1) a kartámasz rögzítősinjé (2) és az ülésalap közé. Tartsa egy helyben a kartámaszt, majd helyezze be és húzza meg a négy csavart (3). A csavarok meghúzásához használja a hatlapfejű csavarkulcsot, és ismételje meg a műveletet a másik oldalon is.

- 5 Távolítsa el a gyárilag elhelyezett csavarokat és betéteket a háttámláról a hatlapfejű csavarkulcs segítségével.

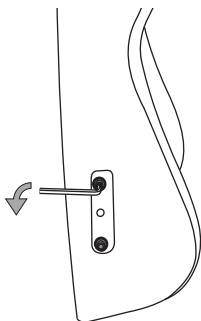

- 6 Távolítsa el a védőhabrétteget az ülésalap tartóelemeiről. Ezután helyezze el óvatosan a háttámlát a tartóelemek között. Helyezze be és húzza meg az 5. lépésben eltávolított négy csavart először a kezével (két-két csavart minden oldalon). Ezután húzza meg őket a hatlapfejű csavarkulccsal. Kezdje az egyes oldalak tetején lévő két csavarral, majd folytassa az alsó kettővel.

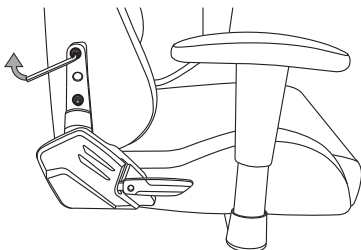



- 7 Helyezze fel az oldalsó burkolatokat, és húzza meg a csavarokat. (A burkolatok „L” jelöléssel vannak ellátva a bal oldalon és „R” jelöléssel belül a jobb oldalon.)

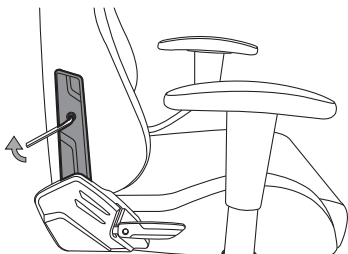

- 8 Fordítsa fejjel lefelé a széket. Ezután távolítsa el a gyárilag elhelyezett csavarokat alulról a betétekkel együtt.

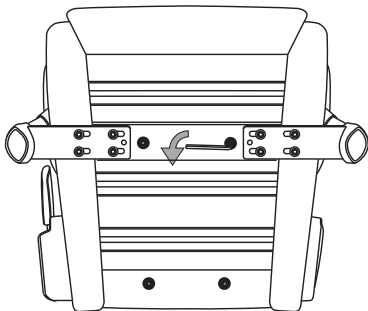

- 9 Ismétlje meg a fenti lépést a vezérlőegység felszereléséhez, majd helyezze el a csavaranyát, és rögzítse vele a hidraulikus emelőhengert oly módon, hogy az ülés hátoldala felé nézzen (ahová a háttámla lett felszerelve).

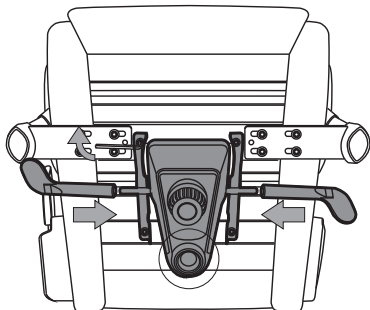

- 10 Illesse be a hidraulikus emelőhenger tetejét a vezérlőegységen lévő rögzítőnyílásba, majd fordítsa a széket függőleges pozícióba. (A biztonság érdekében fontos, hogy két ember végezze ezt a műveletet)

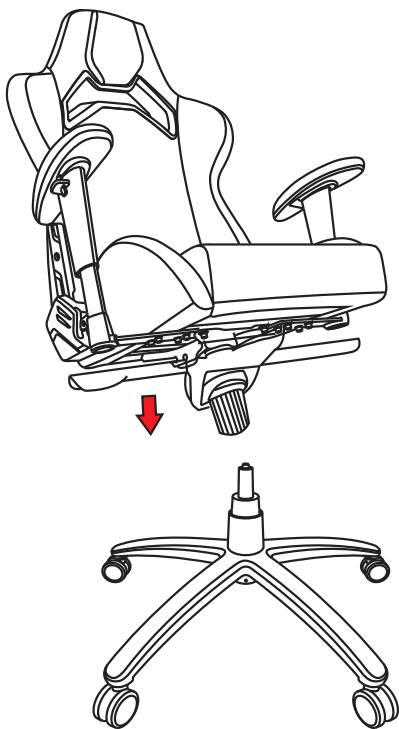

## A szék kivilágítása

1. Helyezze a hordozható akkumulátort a szék hátoldalán található zsebbe.

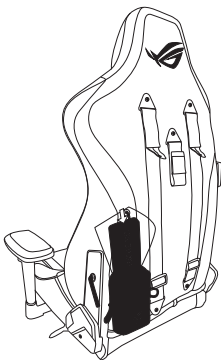

2. Csatlakoztassa az USB Type-A csatlakozót a hordozható akkumulátorhoz.

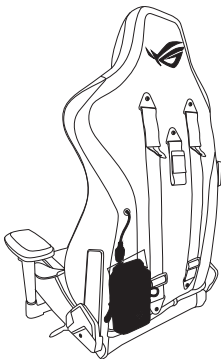

3. A zsebet tépőzárral illesztettük a székhez. Könnyedén leveheti és eltávolíthatja.

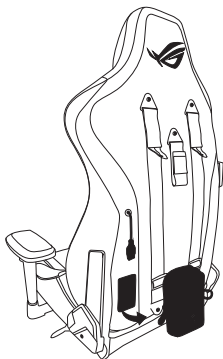

## D Más funkciók

a

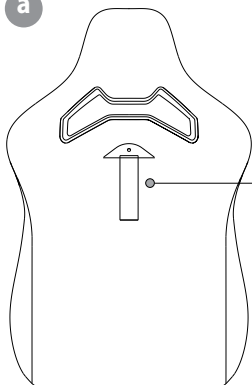

A szék hátoldalán levő akasztó a csomagok, ruhák, poharak, stb. számára.

Maximális terhelés: 2kg

Ne akasszon rá 2 kg-nál súlyosabb tárgyakat.

## b Az RGB kontroller használata

Névleges feszültség: 5V=1A

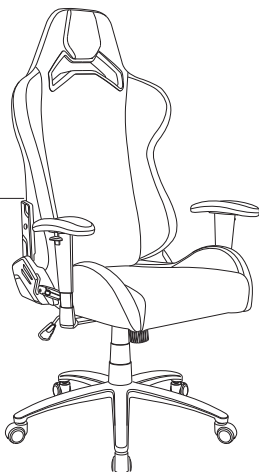
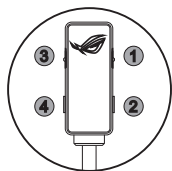

NE távolítsa el a nem leszerelhető vezérlőt, mert ezzel érvénytelenné válik a garancia.

1. Aura RGB világítás: Be / Effektus / Ki

Nyomja meg ismételten az Aura RGB LEDek táplálásának be vagy kikapcsolásához, vagy a 7 effektuson való körbemenéshez: (1) szivárvány (2) légzés (3) színciklus (4) hullám (5) világító jojo (6) villogó (7) statikus

Nyomja meg az Aura RGB világítás gombját 3 másodpercig, hogy kikapcsolja a világítást.

Nyomja meg, hogy újra felébressze vagy csatlakoztassa újra a hordozható akkumulátort, hogy visszaálljon az előző beállításhoz.

**MEGJEGYZÉS:** Az akkumulátor automatikusan állítja a kimenetét amikor a világítás ki van kapcsolva. Csatlakoztassa le és vissza ha az Aura RGB világítás nem ébred fel miután visszakapcsolta.

2. Aura RGB szín

Nyomja meg ismételten, hogy a 8 következő színben körbekapcsoljon: (1) piros (2) narancs (3) sárga (4) zöld (5) kék (6) Indigó (7) lila (8) rózsaszín

**MEGJEGYZÉS:** Ez a funkció csak a következő Aura RGB hatásoknál érvényes - (2) légzés (6) villogó (7) statikus.

3. Aura RGB sebesség: Lassú / Közepes / Gyors

Nyomja meg ismételten, hogy a következő 3 színes sebességeffektuson menjen körbe: (1) Lassú (2) Közepes (3) Gyors

**MEGJEGYZÉS:** Ez a funkció csak a következő Aura RGB hatásoknál érvényes - (1) szivárvány (2) légzés (3) színciklus (4) hullám (5) világító jojo (6) villogó.

4. Aura RGB fényerő: 50% / 75% / 100%

Három fényerőszint. A fényerő egyszerűen érintéssel váltható hogy megfeleljen a környezet világításának és preferenciájának.

5. Visszaállítás gyári alapértékre

Nyomja meg a (2) gombot és (4) gombot egyszerre, hogy visszaállítsa a széket a gyári alapbeállításra.

## E Állítható funkciók

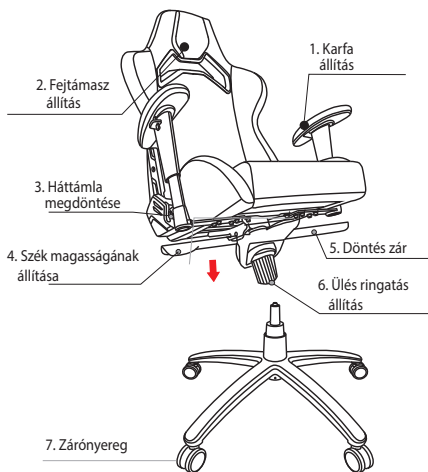

### 1. Karfa állítás



1 Magasság beállítása



2 Előre és hátra

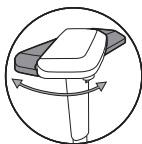

3 Forgás beállítása



4 Befelé és kifelé

## 2. Fejtámasz állítás

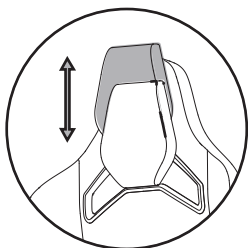

- Magasság állítás (6 cm)
- Kérjük ne emelje túl magasra a fejtámaszt.

## 3. Húzza felfele a kart és lassan dőljön hátra

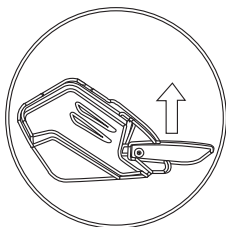

## 4. Szék magasságának állítása

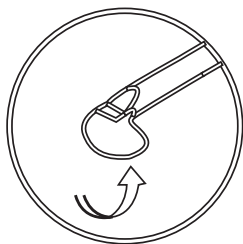

## 5. Zárja le/oldja fel a megdőntő mechanizmust

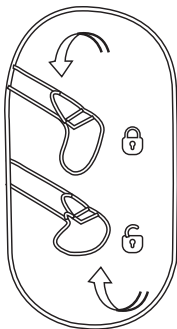



## 6. Ülés ringatás állítás

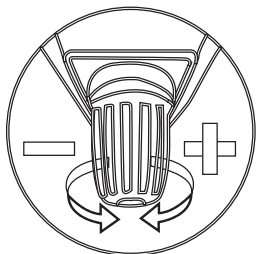

## 7. Zárónyereg

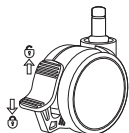

## 안전 고지



- 앉을 때는 등받이에 등을 기대고 의자 중앙에 앉으십시오.



- 의자 가장자리에 앉지 마십시오.



- 의자 위에 올라서지 마십시오.



- 사람이 앉아 있는 동안에는 뒤로 젖힌 등받이를 아래로 누르지 마십시오



- 손과 손가락을 리클라이닝 장치에서 멀리하십시오.

## 경고!

1. 이 의자는 정상적이고 과도하지 않은 방식으로 사용해야 합니다. 당사는 부적절한 조립 및/또는 사용으로 인해 발생한 어떠한 손해에 대해서도 책임지지 않습니다.
2. 최대 권장 하중 무게는 120 KG(264.5파운드)입니다.
3. 부적절한 방식으로 의자를 조립하거나 분해하지 마십시오.
4. 가족을 보호하려면 의자가 직사 광선에 노출되지 않도록 주의하십시오.
5. 등받이가 뒤로 젖힌 위치에서 원위치로 돌아올 때 등을 조심하십시오.
6. 머리 받침대를 위로 당길 때 의자가 손상되지 않도록 무리하게 힘을 가하지 마십시오.
7. LED 모듈을 열어 만지려고 시도하지 마십시오. 그럴 경우 보증이 무효화됩니다.
8. 이 제품의 정격 입력 전력은 5V/1A입니다. 출력이 5V/3A를 초과하는 전원 어댑터를 사용하지 마십시오.

## A 패키지 내용물

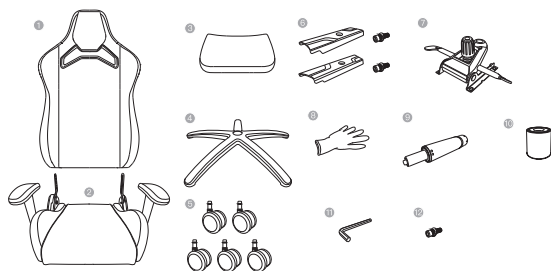

1.	등받이	5.	휠	9.	유압식 리프트 실린더
2.	시트 베이스	6.	볼트로 고정하는 측면 커버	10.	텔레스코핑 커버
3.	등받이 쿠션	7.	제어 장치	11.	육각 렌치
4.	휠 베이스	8.	장갑	12.	예비 볼트

참고: 그림은 참고용으로서, 외관 및 기능이 실제와 다를 수 있습니다.

## B 의자 조립하기

설치하기 전에 장갑을 착용합니다.

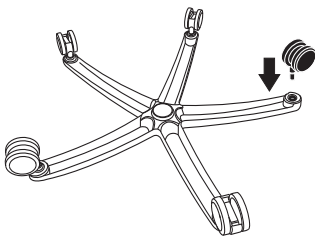

- 1 휠을 하나씩 베이스에 끼우고 누릅니다.

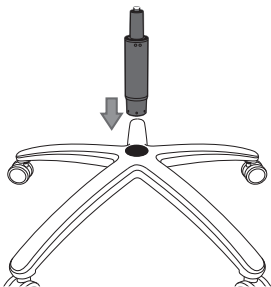

- 2 유압식 리프트 실린더를 베이스의 가운데 구멍에 끼웁니다. 상부에 빨간색 보호 캡이 있는 경우 이를 제거합니다.

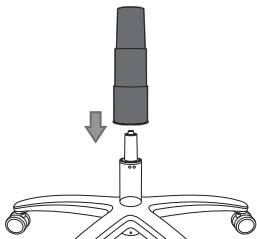

- 3 텔레스코핑 커버를 유압식 리프트 실린더 위에 올려놓습니다.

달리 라벨이 부착되어 있지 않은 경우 팔걸이는 일반적으로 좌우를 구별하여 사용하지 않습니다.

팔걸이가 사전에 조립된 모델의 경우 이 단계를 건너뛰십시오.

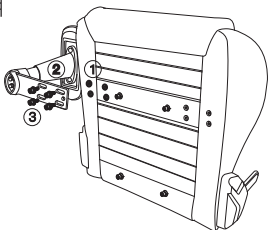

- 4 사전에 조립된 볼트와 와셔 (1) 과 (3) . 를 제거합니다. 4개의 대형 와셔 (1) ) 를 팔걸이 장착 바 (2) 와 시트 베이스 사이에 끼웁니다. 팔걸이를 제자리에 맞춰 끼운 후 4개의 볼트 (3) . 를 모두 조입니다. 육각 렌치를 사용하여 볼트를 모두 조인 후, 반대쪽에서도 동일하게 반복합니다.

- 5 육각 렌치를 사용하여 등받이에서 사전에 조립된 볼트와 와셔를 제거합니다.

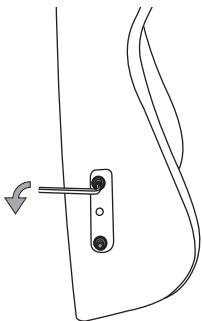

- 6 시트 베이스의 등받이에서 보호용 스티로폼 커버를 제거합니다. 그런 다음 주의해서 브래킷 사이에 등받이를 배치합니다. 앞서 5단계에서 손으로 제거했던 볼트 4개(좌우 측에 각각 2개씩)를 끼워 연결합니다. 그런 다음 육각 렌치를 사용하여 볼트를 조입니다. 먼저 각 측면의 상부에 있는 2개의 볼트부터 조인 후 나머지 하부의 볼트 2개를 조입니다.

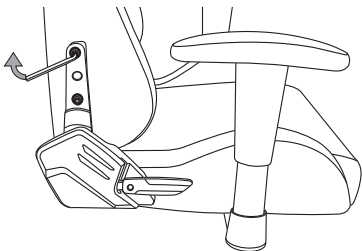

- 7 측면 커버를 설치하고 볼트를 조입니다. (왼쪽 커버의 경우 내부에 "L"이, 오른쪽 커버의 경우 내부에 "R"이 표시되어 있습니다.)

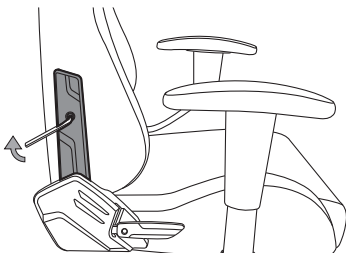

- 8 이제 의자를 거꾸로 뒤집습니다. 그런 다음 밑면에서 4개의 사전 장착된 볼트를 와셔와 함께 제거합니다.

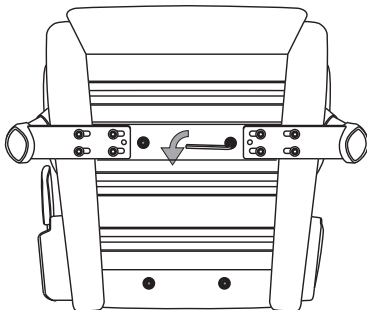

- 9 위의 단계를 반복하여 제어 장치를 설치한 후, 유압식 리프트 실린더가 시트의 뒷면을 향하도록 한 상태에서 너트를 사용하여 실린더를 장착합니다(등받이가 설치된 경우).

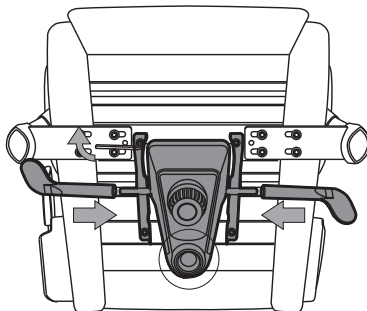

- 10 제어 장치의 장착 구멍에 유압식 리프트 실린더를 끼운 후 의자를 똑바로 세웁니다. (이 경우 안전을 위해 두 사람이 세워야 합니다.)

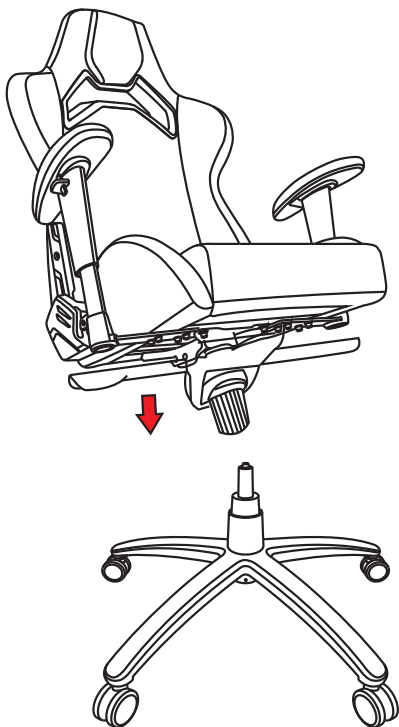

## C 의자 조명 켜기

1. 보조 배터리를 의자 뒷면에 있는 패킷에 넣으십시오.

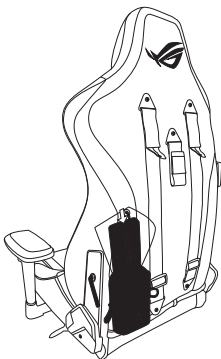

2. USB 타입 A 커넥터를 보조 배터리에 연결하십시오.

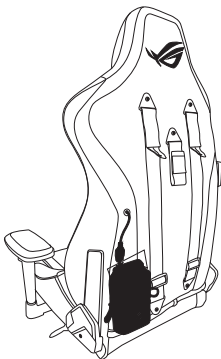



3. 패킷은 벨크로를 사용하여 의자에 부착되어 있습니다. 패킷을 쉽게 제거하여 치울 수 있습니다.

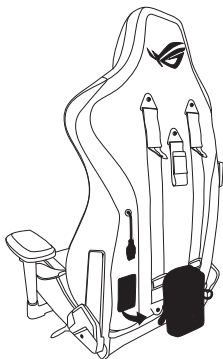

## D 기타 특징

a

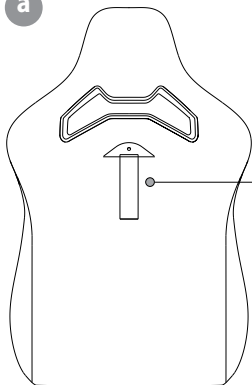

의자 뒷면에 가방, 옷, 컵 등을 걸 수 있는 행거가 달려 있습니다.

최대 하중: 2 kg

2 kg이 넘는 물건을 걸지 마십시오.

## b RGB 컨트롤러 사용법

정격: 5V=1A

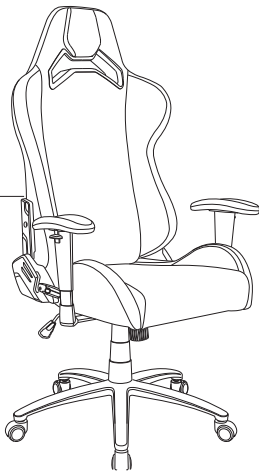
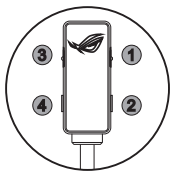

분리할 수 없는 컨트롤러는 분리하지 마십시오. 그럴 경우 보증이 무효화됩니다.

1. Aura RGB 조명: On(켜기)/Effect(효과)/Off(끄기)  
 P반복해서 누르면 Aura RGB LED를 켜고 끄거나, 현재의 7가지 효과 사이를 순환할 수 있습니다: (1) 무지개 (2) 브리딩 (3) 색 순환 (4) 물결 (5) glowing Yo-Yo (반짝이는 요요) (6) 섬광 (7) 정적  
 Aura RGB 조명 버튼을 3초 동안 누르면 조명을 종료할 수 있습니다.  
 버튼을 다시 눌러 절전 모드를 해제하거나 보조 배터리를 다시 연결하면 이전 설정이 유지됩니다.  
  
**참고:** 조명이 종료되면 보조 배터리가 출력을 자동으로 조정할 수 있습니다. 이 버튼을 토글하여 다시 켜도 Aura RGB 조명이 켜지지 않으면 이를 분리했다 다시 연결하십시오.
2. Aura RGB 색  
 반복해서 누르면 눈에 잘 띄는 8가지 색이 다음과 같이 순환됩니다: (1) 빨간색 (2) 주황색 (3) 노란색 (4) 녹색 (5) 파란색 (6) 남색 (7) 보라색 (8) 분홍색  
  
**참고:** 이 기능은 다음 Aura RGB 효과에서만 사용할 수 있습니다- (2) 브리딩(6) 섬광 (7) 정적.
3. Aura RGB 속도: Slow(느리게)/ Medium(보통)/Fast(빠르게)  
 반복해서 누르면 3가지 색 효과 속도가 다음과 같이 순환됩니다: (1) 느리게 (2) 보통 (3) 빠르게  
  
**참고:** 이 기능은 다음 Aura RGB 효과에서만 사용할 수 있습니다- (1) 무지개 (2) 브리딩 (3) 색 순환 (4) 물결 (5) glowing Yo-Yo (반짝이는 요요) (6) 섬광
4. Aura RGB 밝기: 50% / 75% / 100%  
 3가지 밝기 수준. 한 번 눌러 환경 조명과 기본 설정에 맞게 밝기를 전환할 수 있습니다.
5. 공장 모드로 초기화하기  
 버튼 (2)와 버튼 (4)를 동시에 누르면 의자를 공장 기본값으로 초기화할 수 있습니다.

## E 조정 가능한 기능

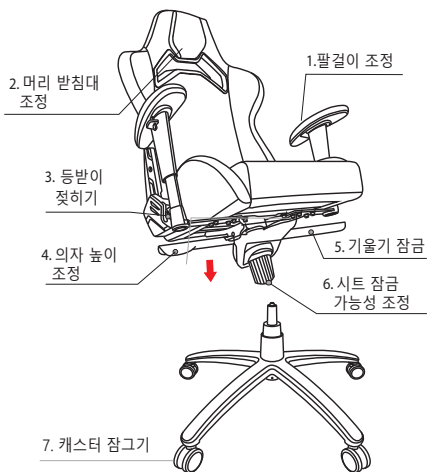

### 1. 팔걸이 조정



① 높이 조정



② 전진 및 후진

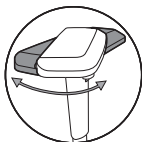

③ 회전 조정



④ 안쪽 또는 바깥쪽 이동

## 2. 머리 받침대 조정

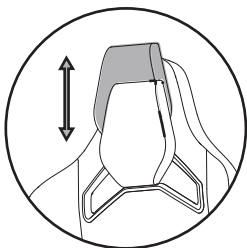

- 높이 조정(6 cm)
- 머리 받침대를 과도하게 올리지 마십시오.

## 3. 레버를 위로 당기면서 상체를 천천히 뒤로 젖히십시오.

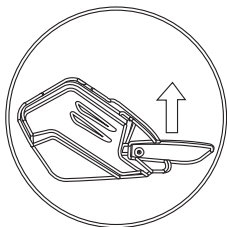

## 4. 의자 높이 조정

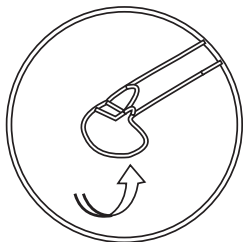

## 5. 기울기 장치의 잠금/잠금 해제

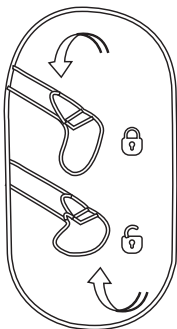

## 6. 시트 잠금 가능성 조정

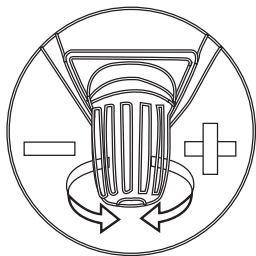

## 7. 캐스터 잠그기

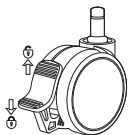

## Maklumat keselamatan



- Duduk di tengah kerusi dengan belakang anda menyandar di tempat sandar.



- Jangan duduk di tepi kerusi.



- Jangan berdiri di atas kerusi.



- Jangan tolak ke bawah pada tempat sandar yang rebah apabila seseorang sedang duduk di atasnya.



- Jauhkan tangan dan jari anda daripada mekanisme rebah.

## AMARAN!

1. Kerusi ini hendaklah digunakan hanya dalam keadaan biasa dan tidak kasar. Kami tidak bertanggungjawab atas sebarang akibat daripada pemasangan dan/atau penggunaan yang salah.
2. Muatan berat maksimum yang disyorkan ialah 120KG (264.5 paun).
3. Jangan sekali-kali pasang atau tanggalkan kerusi anda dengan cara yang salah.
4. Sila pastikan kerusi anda berada jauh daripada pancaran cahaya matahari untuk melindungi kulitnya.
5. Sila perhatikan belakang anda apabila tempat sandar kembali ke kedudukan asalnya dari kedudukan rebah.
6. Untuk mengelak kerosakan pada kerusi anda, jangan gunakan daya berlebihan untuk menarik tempat letak kepala anda ke atas.
7. Jangan sekali-kali cuba untuk membuka dan menyentuh modul LED kerana ia akan membatalkan waranti.
8. Perkadaran input kuasa untuk produk ini ialah 5V/1A. Jangan guna penyesuai kuasa dengan output yang melebihi 5V/3A.

## A Kandungan Bungkusan

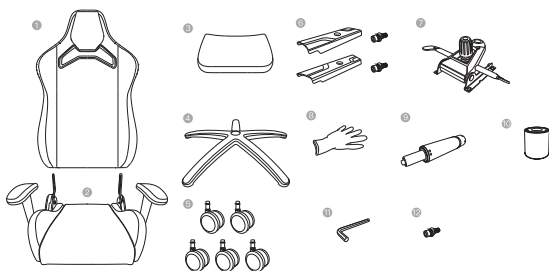

1.	Tempat sandar	5.	Roda	9.	Silinder pengangkut hidraulik
2.	Tapak tempat duduk	6.	Penutup tepi dengan bolt	10.	Penutup teleskop
3.	Kusyen lumbar	7.	Unit kawalan	11.	Kunci Alien
4.	Tapak roda	8.	Sarung tangan	12.	Bolt ganti

**Nota:** Ilustrasi adalah untuk rujukan sahaja dan mungkin berbeza daripada kerusi sebenar anda dari segi penampilan dan ciri-ciri.



## B Memasang kerusi anda

Pakai sarung tangan sebelum pemasangan.

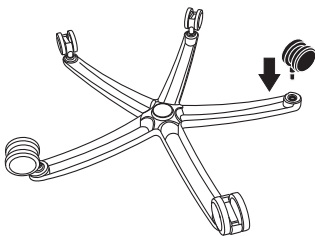

- 1 Masukkan dan tolak roda satu per satu ke dalam tapak.

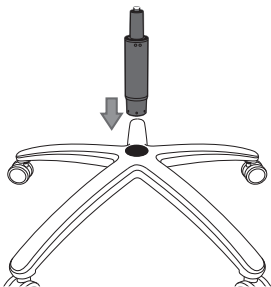

- 2 Masukkan silinder pengangkut hidraulik ke dalam lubang tengah tapak. Tanggalkan tudung pelindung merah di bahagian atas jika ada.

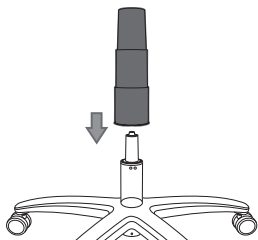

- 3 Letakkan penutup teleskop di bahagian atas silinder pengangkut hidraulik.

Tempat letak lengan biasanya tidak membezakan bahagian tepi kecuali dilabelkan sebaliknya.

Untuk model yang telah dipaparkan tempat letak lengan, sila langkai langkah ini.

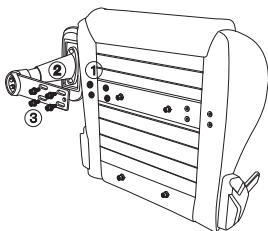

- 4 Tanggalkan bolt dan sesendal yang telah dipaparkan (1 & 3). Letakkan 4 sesendal besar (1) di antara bar pelekapan tempat letak lengan (2) dan tapak tempat duduk. Letakkan tempat letak lengan di tempatnya, kemudian masukkan dan ketatkan semua 4 bolt (3). Gunakan kunci alien untuk mengetatkan semuanya dan ulang pada bahagian satu lagi.

- 5 Gunakan kunci alien untuk menanggalkan bolt dan sesendal yang dipaparkan daripada tempat sandar.

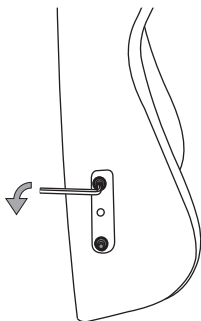

- 6 Tanggalkan penutup busa pelindung daripada braket tapak tempat duduk. Kemudian, ubah kedudukan tempat sandar dengan berhati-hati di antara braket. Masukkan dan pasang 4 bolt (2 pada setiap bahagian) yang anda tanggalkan dalam langkah 5 menggunakan tangan terlebih dahulu. Kemudian, gunakan kunci alien untuk mengetatkannya. Mulakan dengan dua bolt di bahagian atas setiap sisi, kemudian bahagian bawah dua.

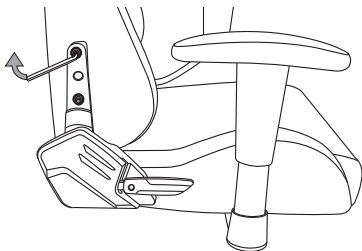

- 7 Pasang penutup tepi dan ketatkan bolt. (Penutup ditandai "L" untuk bahagian kiri dan "R" untuk bahagian kanan.)

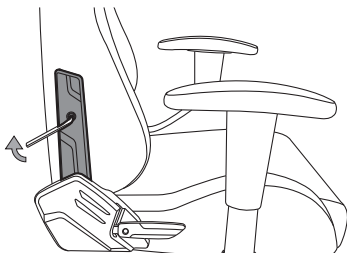

- 8 Sekarang lipat kerusi, menghadap ke bawah. Kemudian, tanggalkan 4 bolt yang diprapasang dari bahagian bawah dengan sesendal.

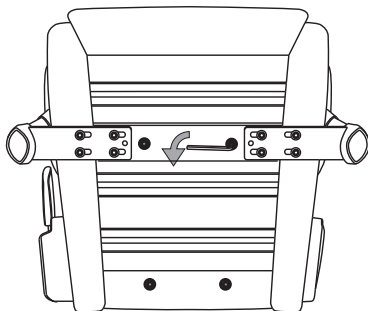

- 9 Ulang langkah di atas untuk memasang unit kawalan dan kemudian, letakkan nat untuk memasang silinder pengangkut hidraulik menghadap belakang tempat duduk (jika tempat sandar dipasang).

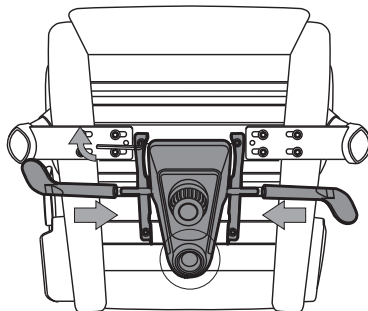

- 10 Masukkan bagian atas silinder pengangkut hidrolik ke dalam lubang pemasangan pada unit kawalan dan kemudian, pusingkan kerusi dalam kedudukan menegak. (Pengendalian dua orang diperlukan untuk keselamatan anda)

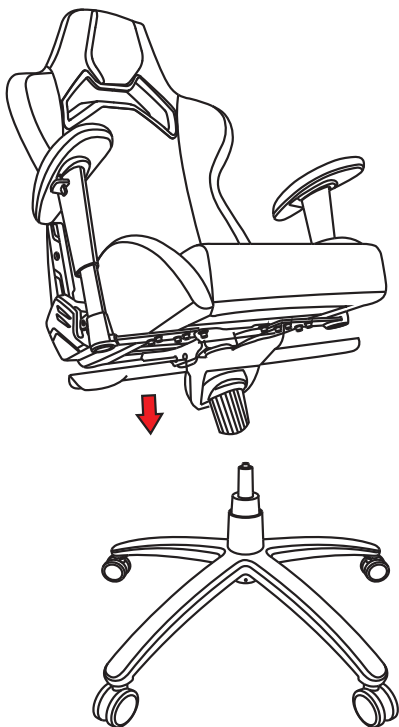

## **C** Menerangi kerusi anda

1. Letakkan bank kuasa anda ke dalam paket di belakang kerusi.

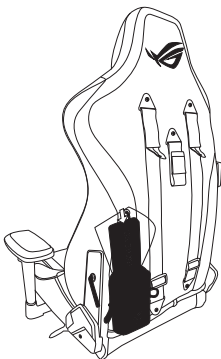

2. Sambungkan penyambung USB Jenis A ke bank kuasa anda.

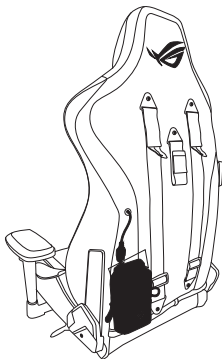

3. Paket dilekapkan ke kerusi anda dengan Velcro. Anda boleh menanggalkannya dengan mudah dan bawa ia pergi.

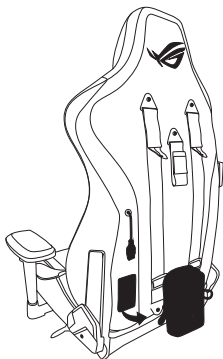

## D Ciri-ciri lain

a

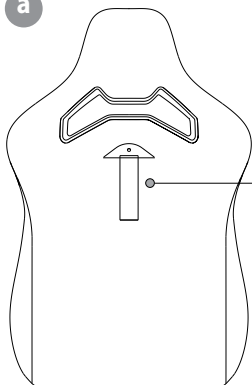

Penyangkut di bahagian belakang kerusi untuk menyangkut beg anda, pakaian, cawan dan banyak lagi. Muatan maksimum: 2kg. Jangan gantung item melebihi 2 kg.

## b Menggunakan pengawal RGB

Perkadaran: 5V=1A

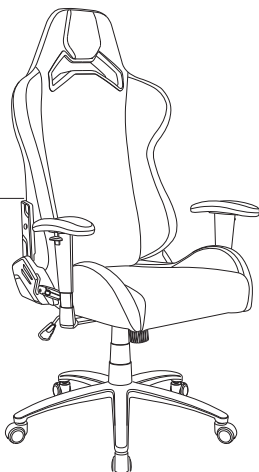
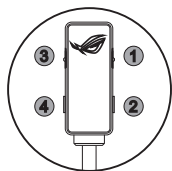

JANGAN tanggalkan pengawal tidak boleh lekap kerana ia akan membatalkan waranti.

1. Pencahayaan RGB Aura: Hidup / Kesan / Mati

Tekan berulang kali untuk menghidupkan atau mematikan kuasa LED RGB Aura, atau kitaran menerusi 7 kesan semasa: (1) pelangi (2) pernafasan (3) warna kitaran (4) gelombang (5) berkilauan Yo-Yo (6) strob (7) statik

Tekan butang Pencahayaan RGB Aura selama 3 saat untuk menamatkan pencahayaan.

Tekannya untuk membangkitkan ia sekali lagi atau menyambung semula bank kuasa anda akan mengekalkan tetapan sebelumnya.

**NOTA:** Bank kuasa anda mungkin melaraskan outputnya secara automatik apabila pencahayaan ditamatkan. Putuskan sambungan dan sambungkannya semula jika Pencahayaan RGB Aura tidak boleh bangkit selepas menogolnya kembali hidup.

2. Warna RGB Aura

Tekan berulang kali untuk mengitar menerusi 8 warna berikut yang menarik: (1) merah (2) oren (3) kuning (4) hijau (5) biru (6) Indigo (7) ungu (8) merah jambu

**NOTA:** Ciri ini hanya boleh didapati pada kesan RGB Aura berikut: (2) pernafasan (6) strob (7) statik

3. Kelajuan RGB Aura: Perlahan / Sederhana / Laju

Tekan berulang kali untuk mengitar menerusi 3 kelajuan kesan warna berikut: (1) Perlahan (2) Sederhana (3) Laju

**NOTA:** Ciri ini hanya boleh didapati pada kesan RGB Aura berikut: (1) pelangi (2) pernafasan (3) warna kitaran (4) gelombang (5) berkilauan Yo-Yo (6) strob

4. Kecerahan RGB Aura: 50% / 75% / 100%

Tiga tahap kecerahan. Kecerahan boleh ditukar dengan ketikan mudah untuk sesuai dengan pencahayaan persekitaran dan keutamaan.

5. Tetapkan semula kepada mod kilang

Tekan butang(2) dan butang(4) secara serentak untuk menetapkan semula kerusi anda kepada lalai kilangnya.



## E Fungsi boleh laras

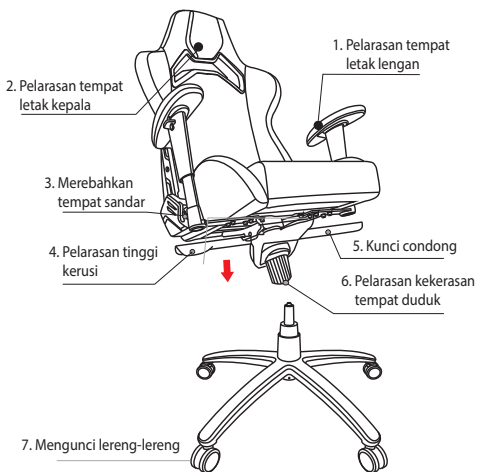

### 1. Pelarasan tempat letak lengan

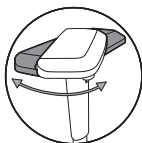

## 2. Pelarasan tempat letak kepala

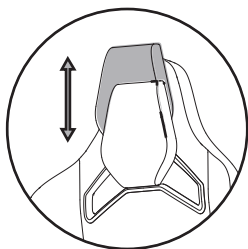

- Pelarasan tinggi (6cm)
- Jangan naikkan tempat letak kepala anda secara berlebihan.

## 3. Tarik tuil ke atas dan perlahan-lahan sandar ke belakang

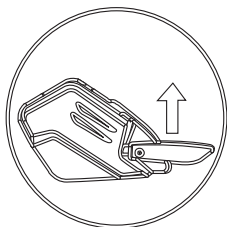

## 4. Pelarasan tinggi kerusi

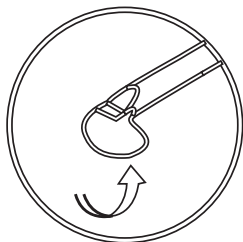

## 5. Mekanisme kunci/ buka kunci condong

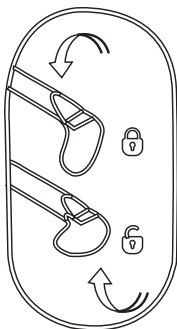

## 6. Pelarasan kekerasan tempat duduk

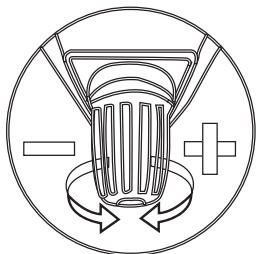

## 7. Mengunci lereng-lereng

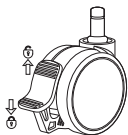

## Sikkerhetsmerknader



- Sitt i midten av stolen med ryggen mot ryggstøtten.



- Ikke sitt på kanten av stolen.



- Ikke stå på stolen.



- Ikke trykk ned på den bakoverlente ryggstøtten når noen person sitter.



- Hold hender og fingre vekk fra lenemekanismen.

## ADVARSEL!

1. Stolen skal kun brukes på normal måte og ikke misbrukes. Vi er ikke ansvarlige for eventuelle skader som følger av feil montering og/eller bruk.
2. Maksimale anbefalte vektbelastning er 120 kg (264,5 pund).
3. Stolen skal ikke monteres eller demonteres på feil måte.
4. Hold stolen ute av direkte sollys for å beskytte skinnet.
5. Pass på ryggen når du tar ryggstøtten tilbake startposisjon fra bakoverlent posisjon.
6. For å unngå skader på stolen må du ikke bruke for mye kraft til å trekke opp nakkestøtten.
7. Forsøk aldri å åpne og berøre LED-modulen, da dette gjør garantien ugyldig.
8. Strøminngangsklassifiseringen på dette produktet er 5 V / 1 A. Ikke bruk en strømadapter med en utgang over 5 V / 3 A.

## A Pakkens innhold

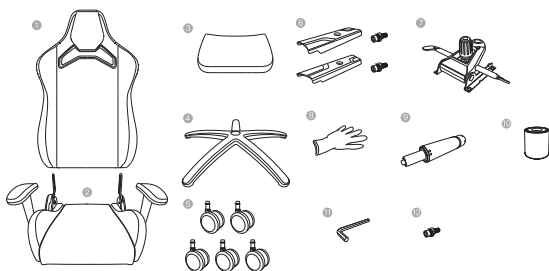

1.	Ryggstøtte	5.	Hjul	9.	Hydraulisk løftesyylinder
2.	Setebase	6.	Sidedeksler med bolter	10.	Teleskopdeksel
3.	Korsryggpute	7.	Kontrollenhet	11.	Unbrakonøkkel
4.	Hjulbase	8.	Hansker	12.	Reservebolt

**MERK:** Illustrasjonene er kun til referanse og kan avvike fra den faktiske stolen i utseende og funksjonalitet.

## B Montere stolen

Ta på hansker før installasjon.

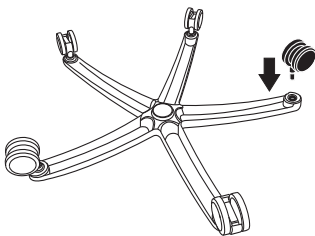

- 1 Sett inn og skyv hjulene i basen én og én.

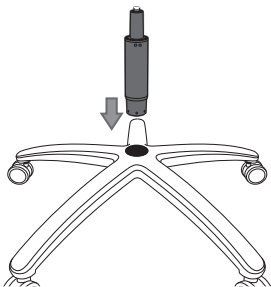

- 2 Sett den hydrauliske løftesynderen inn i midthullet på basen. Hvis det er en rød beskyttelseshette på toppen, tar du den av.

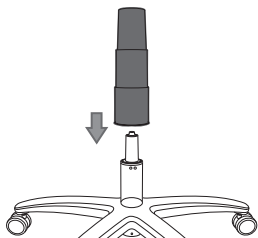

- 3 Plasser teleskopdekslet på toppen av den hydrauliske løftesynderen.

Det er ikke forskjell på høyre og venstre armlene med mindre dette står merket.

På modeller der armlenene er ferdigmontert hopper du over dette trinnet.

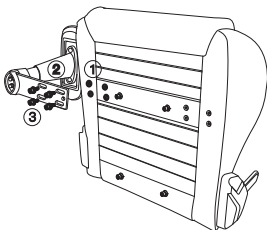

- 4 Fjern de forhåndsmonterte boltene og skivene (1) og (3). Legg de 4 store skivene (1) mellom armlenet (2) og setebasen. Hold armlenet på plass, og sett inn og stram til alle 4 bolter (3). Bruk unbrakonøkkelen til å stramme alle, og gjenta på den andre siden.
- 5 Bruk unbrakonøkkelen til å fjerne de ferdigmonterte boltene og skivene fra ryggstøtten.

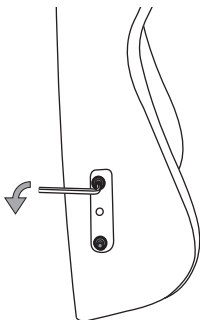

- 6 Fjern de beskyttende skumdekslene fra brakettene på setebasen. Plasser deretter ryggstøtten forsiktig mellom brakettene. Sett inn og fest de 4 boltene (2 på hver side) du tok av i trinn 5 først for hånd. Bruk deretter unbrakonøkkelen til å stramme dem. Begynn med de to boltene på toppen på hver side, og fortsett med de to på bunnen.

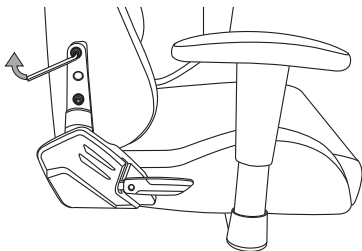

- 7 Monter sidedekslene, og stram boltene. (Dekslene er merket på innsiden med «L» for venstre og «R» for høyre.)

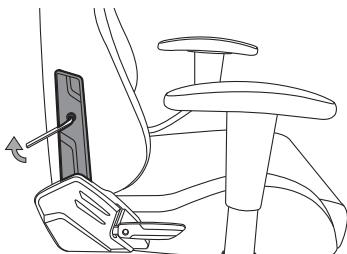

- 8 Snu nå stolen slik at den står vendt nedover. Fjern deretter de 4 forhåndsmonterte boltene fra undersiden med skivene.

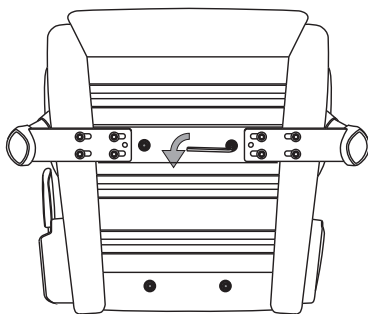

- 9 Gjenta trinnet over for å montere kontrollenheten, og plasser deretter mutteren for å montere den hydrauliske løftesylinderen på baksiden av setet (der ryggstøtten er installert).

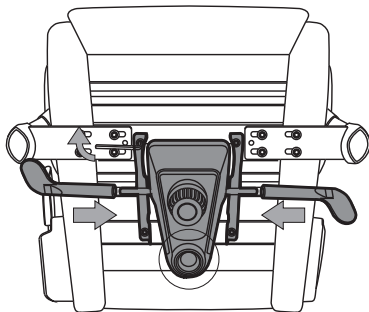



- 10 Sett toppen av den hydrauliske løftesynderen inn i monteringshullet på kontrollenheten, og vend stolen over i oppreist stilling. (Man må være to personer av sikkerhetsmessige hensyn)

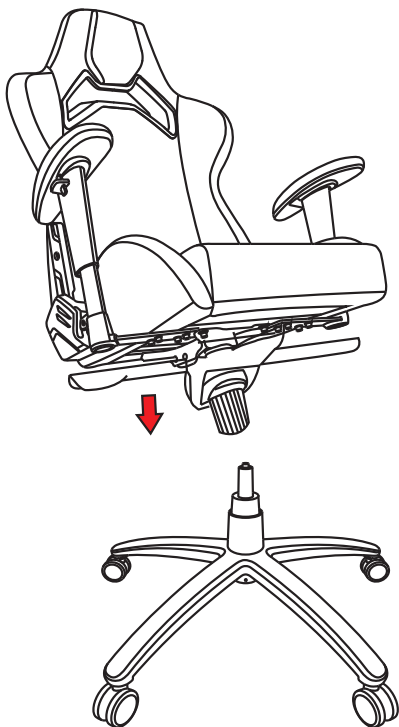

## Lyse opp stolen

1. Legg strømbanken i pakken på baksiden av stolen.

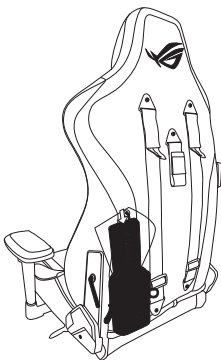

2. Koble USB Type-A-kontakten til strømbanken.

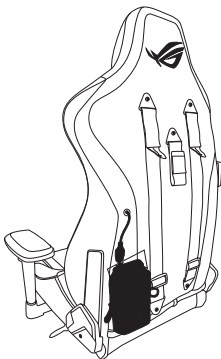

3. Pakken festes til stolen med borrelås. Den kan enkelt tas av og bort.

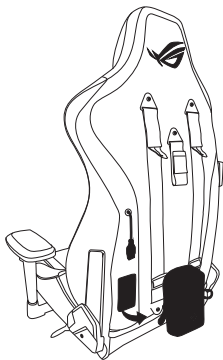

## D Andre funksjoner

a

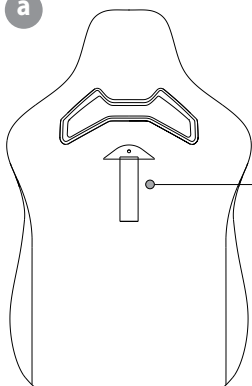

Hengeren på baksiden av stolen kan brukes til å henge poser, klær, kopper eller mer.

Maksimal belastning: 2 kg

Ikke heng noe over 2 kg.

## b Bruke RGB-kontrolleren

Klassifisering: 5V=1A

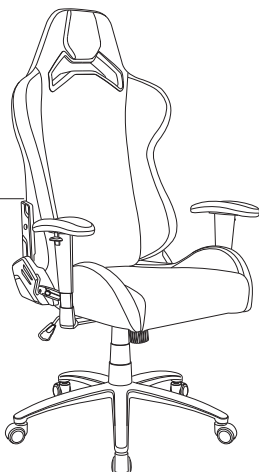
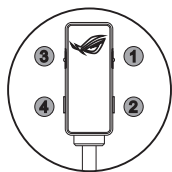

IKKE fjern den ikke-avtakbare kontrolleren, da dette vil gjøre garantien ugyldig.

1. Aura RGB-belysning: På/Effekt/Av

Trykk flere ganger for å slå Aura RGB-LED på eller av og for å bla gjennom de 7 effektene: (1) regnbue (2) pusting (3) farge syklus (4) bølge (5) glødende Yo-Yo (6) strobe (7) statisk

Hold inne Aura RGB-belysningsknappen i 3 sekunder for å slå av belysningen.

Trykk den for å vekke igjen, eller koble til strømbanken igjen, så beholdes forrige innstilling.

**MERK:** Strømbanken justerer automatisk effekten når belysningen slås av. Koble fra og koble til igjen hvis Aura RGB-belysningen ikke vekkes igjen etter at den slås på igjen.

2. Aura RGB-farge

Trykk gjentatte ganger for å bla gjennom følgende 8 flotte farger: (1) rød (2) orange (3) gul (4) grønn (5) blå (6) indigo (7) lilla (8) rosa

**MERK:** Denne funksjonen er kun tilgjengelig med følgende Aura RGB-effekter: (2) pusting (6) strobe (7) statisk

3. Aura RGB-hastighet: Sakte / Middels / Rask

Trykk gjentatte ganger for å bla gjennom følgende 3 fargeeffekthastigheter: (1) Sakte (2) Middels (3) Rask

**MERK:** Denne funksjonen er kun tilgjengelig med følgende Aura RGB-effekter: (1) regnbue (2) pusting (3) farge syklus (4) bølge (5) glødende Yo-Yo (6) strobe

4. Aura RGB-lysstyrke: 50% / 75% / 100%

Tre lysstyrkenivåer. Lysstyrken kan endres med ett enkelt trykk for å passe til omgivelsesbelysningen og dine preferanser.

5. Tilbakestill til fabrikkmodus

Trykk knappen (2) og knappen (4) samtidig for å tilbakestille stolen til fabrikkinnstillingene.

## E Justeringsfunksjoner

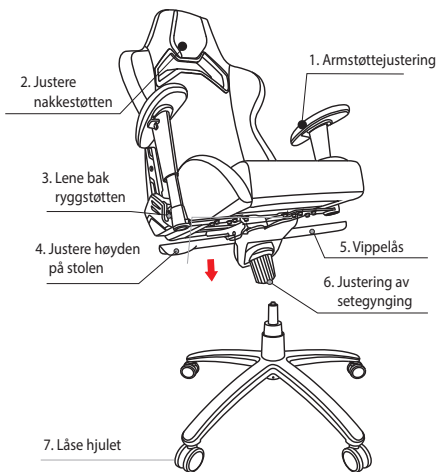

### 1. Armstøttejustering

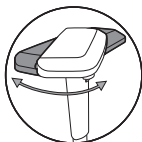

## 2. Justere nakkestøtten

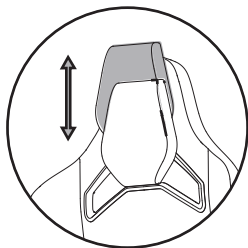

- Høydejustering (6 cm)
- Ikke løft nakkestøtten opp for høyt.

## 3. Trekk opp spaken, og len deg sakte tilbake.

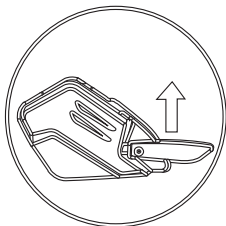

## 4. Justere høyden på stolen

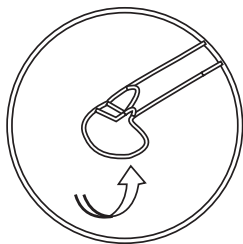

## 5. Låse / låse opp vippemekanismen

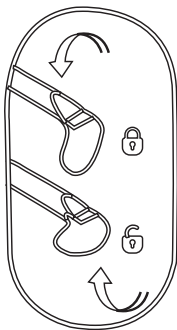

## 6. Justering av setegynging

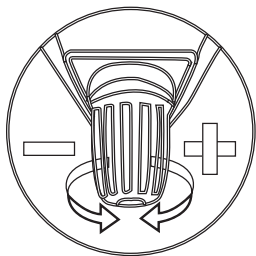

## 7. Låse hjulet

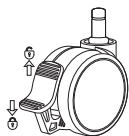



## Avisos de segurança



- Sente-se no centro da cadeira com as costas encostadas ao encosto.



- Não se sente na extremidade da cadeira.



- Não se coloque em pé em cima da cadeira.



- Não empurre o encosto reclinado para baixo quando uma pessoa estiver sentada.



- Mantenha as mãos e dedos afastados do mecanismo de reclinção.

## AVISO!

1. Esta cadeira deve ser utilizada apenas de forma normal e não abusiva. Não nos responsabilizamos por quaisquer danos resultantes de montagem e/ou uso incorretos.
2. O peso máximo recomendado é de 120 KG.
3. Nunca monte ou desmonte a cadeira de forma inadequada.
4. Mantenha a cadeira afastada de luz solar direta para proteger o couro.
5. Tenha em atenção às suas costas quando o encosto voltar à sua posição original a partir de uma posição reclinada.
6. Para evitar danificar a cadeira, não utilize força excessiva para puxar o apoio de cabeça.
7. Nunca tente abrir e tocar no módulo LED, pois invalidará a garantia.
8. A potência de entrada deste produto é de 5V/1A. Não utilize um transformador com uma potência que exceda 5V/3A.

## A Conteúdo da embalagem

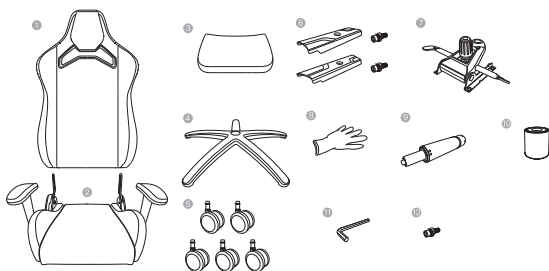

1.	Encosto	5.	Rodas	9.	Cilindro de elevação hidráulico
2.	Base do assento	6.	Tampas laterais com parafusos	10.	Tampa telescópica
3.	Almofada lombar	7.	Unidade de controlo	11.	Chave sextavada
4.	Base das rodas	8.	Luvas	12.	Parafuso sobresselente

**Nota:** As ilustrações servem apenas como referência e podem ser diferentes da sua cadeira em termos de aparência e características.

## B Montar a cadeira

Calce as luvas antes da instalação.

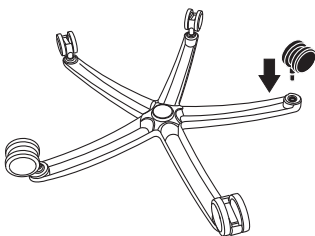

- 1 Introduza e empurre as rodas, uma a uma, até encaixarem na base.

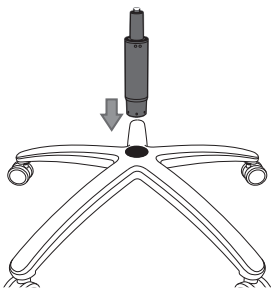

- 2 Introduza o cilindro de elevação hidráulico no orifício central da base. Remova a tampa de proteção vermelha no topo, se existir.

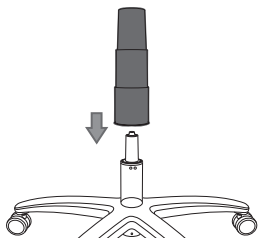

- 3 Coloque a tampa telescópica no topo do cilindro de elevação hidráulica.

Normalmente, não se distingue o apoio para braços esquerdo do direito, exceto se houver indicação em contrário.

No caso de modelos com apoio para braços previamente montado, ignore este passo

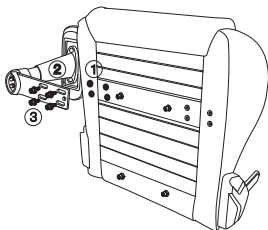

- 4 Remova os parafusos e as anilhas previamente montados (1 e 3). Coloque as 4 anilhas grandes (1) entre a barra de montagem do apoio para braços (2) e a base do assento. Mantenha o apoio para braços no sítio, depois introduza e aperte os 4 parafusos (3). Utilize a chave sextavada para apertá-los e repita no outro lado.

- 5 Utilize a chave sextavada para remover do encosto os parafusos e anilhas previamente montados.

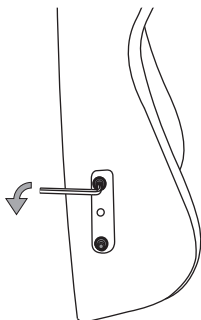

- 6 Remova os revestimentos protetores de espuma dos suportes da base do assento. Em seguida, coloque cuidadosamente o encosto entre os suportes. Introduza e fixe os 4 parafusos (2 de cada lado) que removeu primeiro à mão no passo 5. Em seguida, utilize a chave sextavada para os apertar. Comece com os dois parafusos no topo de cada lado, e depois os dois na parte inferior.

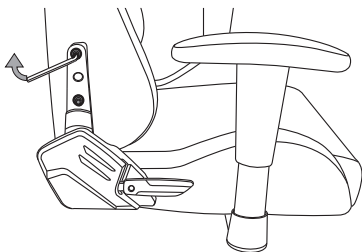

- 7 Instale as tampas laterais e aperte os parafusos. (As tampas estão marcadas com "L" para o lado esquerdo e "R" para o lado direito).

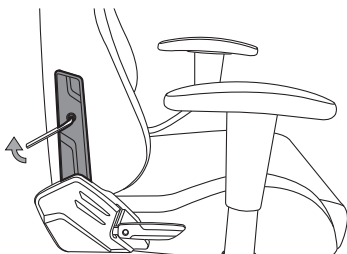

- 8 Agora vire a cadeira ao contrário, voltada para baixo. Em seguida, remova os 4 parafusos previamente montados na parte inferior com anilhas.

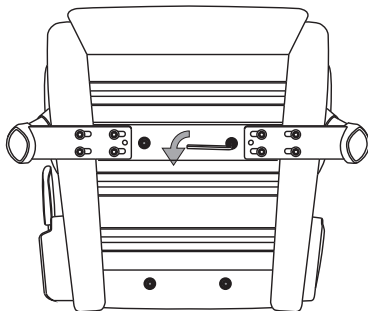

- 9 Repita o passo acima para instalar a unidade de controle, e, em seguida, coloque a porca para montar o cilindro de elevação hidráulico voltado para a traseira do assento (onde está instalado o encosto).

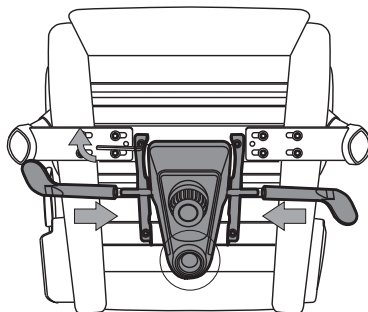

- 10 Introduza o topo do cilindro de elevação hidráulico no orifício de montagem na unidade de controlo, e, em seguida, vire a cadeira e coloque-a na posição vertical. (Para sua segurança, o manuseamento deve ser realizado por duas pessoas)

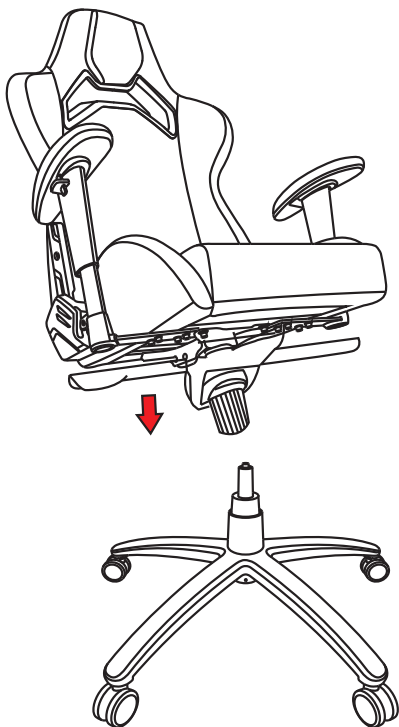

## **C** Iluminar a cadeira

1. Coloque o seu powerbank no bolso existente nas costas da cadeira.

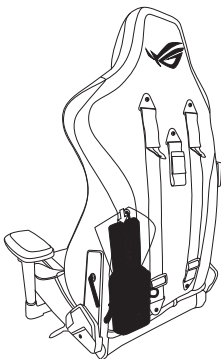

2. Ligue o conector USB Tipo A ao seu powerbank.

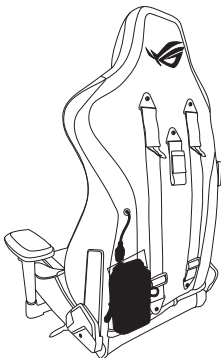

3. O bolso está fixado à cadeira com um velcro. Pode removê-lo com facilidade.

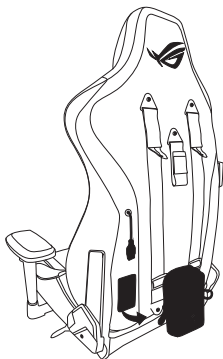



## D Outras características

a

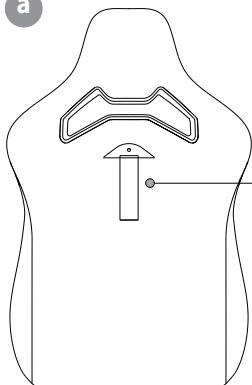

Gancho nas costas da cadeira para pendurar sacos, roupa, copos, etc.  
Carga máxima: 2 kg  
Não pendure objetos com um peso superior a 2 kg.

## b Utilizar o comando RGB

Potência: 5V=1A

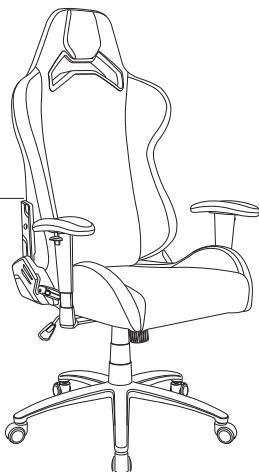
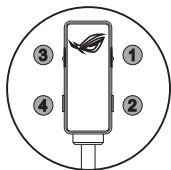

**NÃO** remova o controlador não amovível, pois invalidará a garantia.

1. Iluminação Aura RGB: Ligar / Efeito / Desligar

Pressione repetidamente para ligar ou desligar os LED Aura RGB, ou alternar entre os 7 efeitos de iluminação: (1) arco-íris (2) respiração (3) ciclo de cor (4) onda (5) Yo-Yo brilhante (6) estroboscópio (7) estático

Pressione o botão de iluminação Aura RGB durante 3 segundos para desligar a iluminação.

Pressione reativar ou ligue o seu powerbank para manter a definição anterior.

**NOTA:** O seu powerbank poderá ajustar automaticamente a potência de saída quando a iluminação estiver desligada. Desligue e volte a ligá-lo se a iluminação Aura RGB não for possível reativar a iluminação.

2. Cor Aura RGB

Pressione repetidamente para alternar entre as 8 cores vividas seguintes: (1) vermelho (2) laranja (3) amarelo (4) verde (5) azul (6) Índigo (7) roxo (8) rosa

**NOTA:** Esta funcionalidade está disponível apenas nos efeitos Aura RGB seguintes: - (2) respiração (6) estroboscópio (7) estático.

3. Velocidade Aura RGB: Lento / Médio / Rápido

Pressione repetidamente para alternar entre as 3 velocidades de efeitos de cor: (1) Lento (2) Médio (3) Rápido

**NOTA:** Esta funcionalidade está disponível apenas nos efeitos Aura RGB seguintes: (1) arco-íris (2) respiração (3) ciclo de cor (4) onda (5) Yo-Yo brilhante (6) estroboscópio

4. Brilho Aura RGB: 50% / 75% / 100%

Três níveis de brilho. O brilho pode ser alterado com apenas um toque para se adequar à iluminação ambiente.

5. Repor modo de fábrica

Pressione os botões (2) e (4) em simultâneo para repor as predefinições da cadeira.

## **E** Funções ajustáveis

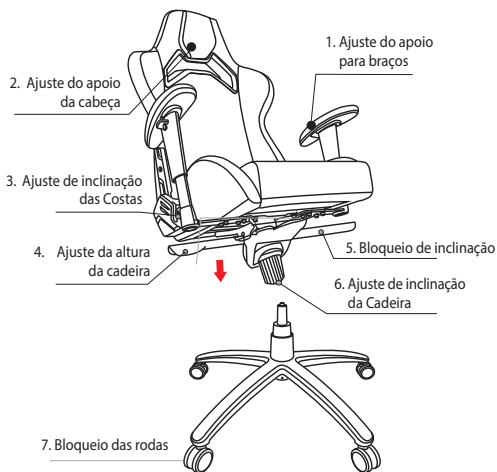

### **1. Ajuste do apoio para braços**



1 Ajuste da altura



2 Para a frente e para trás

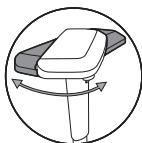

3 Ajuste da rotação



4 Para dentro e para fora

## 2. Ajuste do apoio da cabeça

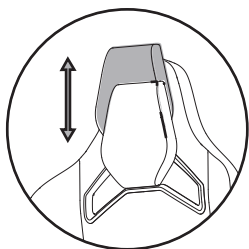

- Ajuste de altura (6 cm)
- Não eleve demasiado o apoio da cabeça.

## 3. Puxe a alavanca para cima e encoste-se lentamente para trás.

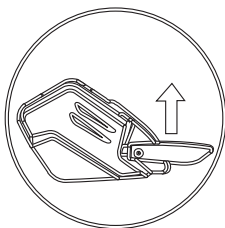

## 4. Ajuste da altura da cadeira

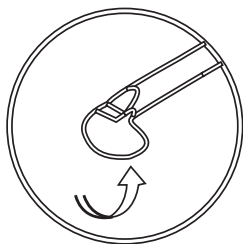

## 5. Bloquear/desbloquear o mecanismo de inclinação

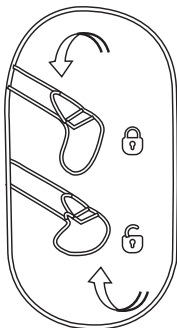

## 6. Ajuste de inclinação da Cadeira

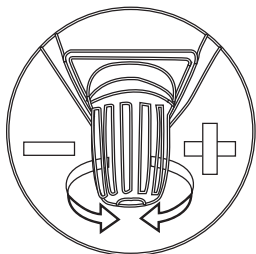

## 7. Bloqueio das rodas

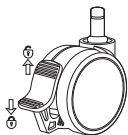

## Uwagi dotyczące bezpieczeństwa



- Należy usiąść na środku fotela z plecami na oparciu.



- Nie wolno siadać na krawędzi fotela.



- Nie wolno stawać na fotelu.



- Nie wolno przechylać w dół opuszczonego oparcia, gdy na fotelu ktoś siedzi.



- Nie wolno zbliżać rąk ani palców do mechanizmu opuszczania.

## OSTRZEŻENIE!

1. Z fotela można korzystać wyłącznie w normalny i niestwarzający zagrożenia sposób. Firma nie ponosi odpowiedzialności za jakiegokolwiek szkody wynikające z niewłaściwego montażu i/lub użytkowania.
2. Maksymalne zalecane obciążenie wynosi 120 kg (264,5 funta).
3. Nie należy nigdy montować ani demontować fotela w niewłaściwy sposób.
4. W celu ochrony skóry fotela należy stawiać go poza zasięgiem bezpośredniego światła słonecznego.
5. Podczas przywracania oryginalnego położenia oparcia z pozycji opuszczonej należy uważać na plecy.
6. Aby uniknąć uszkodzenia fotela, nie wolno wyciągać zagłówka z nadmierną siłą.
7. Nie należy nigdy otwierać ani dotykać modułu LED, ponieważ unieważniłoby to gwarancję.
8. Wartości znamionowe wejścia zasilania tego produktu to 5 V/1 A. Nie wolno korzystać z zasilacza o parametrach wyjściowych przekraczających 5 V/3 A.

## A Zawartość opakowania

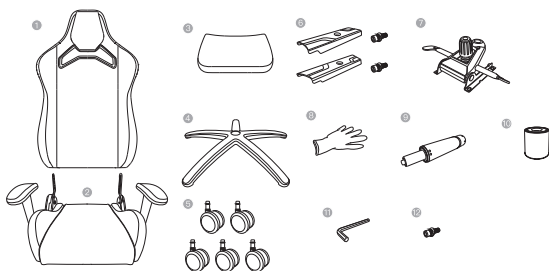

1.	Oparcie	5.	Kółka	9.	Siłownik hydrauliczny
2.	Siedzisko	6.	Oslony boczne ze śrubami	10.	Oslona teleskopowa
3.	Poduszka lędźwiowa	7.	Moduł sterowania	11.	Klucz imbusowy
4.	Podstawa na kółka	8.	Rękawice	12.	Zapassowa śruba

**Uwaga:** Rysunki mają charakter wyłącznie informacyjny i mogą różnić się od rzeczywistego wyglądu i funkcji fotela.

## B Montaż fotela

Przed montażem należy założyć rękawice.

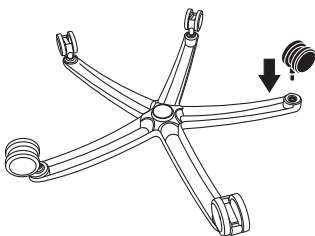

- 1 Włóż i dociśnij kolejno wszystkie kółka do podstawy.

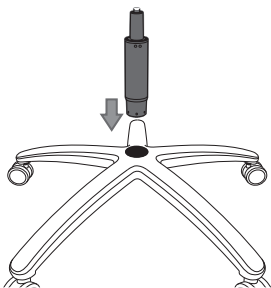

- 2 Włóż siłownik hydrauliczny do otworu na środku podstawy. Zdejmij z górnej części czerwoną nasadkę ochronną, jeśli była tam umieszczona.

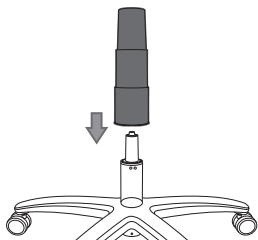

- 3 Załóż osłonę teleskopową na siłownik hydrauliczny.



Podłokietniki nie są zwykle ograniczone do jednej ze stron, chyba że jest to wyraźnie oznaczone.

W przypadku modeli ze wstępnie zamocowanymi podłokietnikami krok ten należy pominąć.

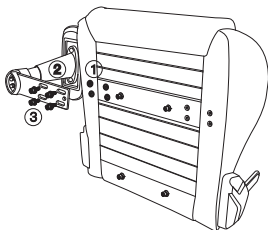

- 4 Wykręć wstępnie zamocowane śruby z podkładkami (1) i (3). Umieść 4 duże podkładki (1) między drążkiem montażowym podłokietników (2) a siedziskiem. Przytrzymaj podłokietnik, a następnie włóż i przykręć wszystkie 4 śruby (3). Dokręć je przy użyciu klucza imbusowego i powtórz czynność przy drugim podłokietniku.

- 5 Przy użyciu klucza imbusowego wykręć z oparcia wstępnie zamocowane śruby z podkładkami.

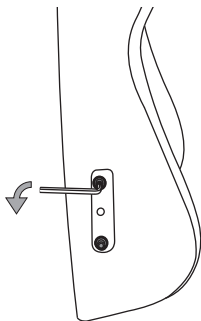

- 6 Zdejmij piankę ochronną ze wsporników siedziska. Następnie umieść ostrożnie oparcie między wspornikami. Włóż i przykręć ręcznie 4 śruby (po 2 z każdej strony) wykręcone w kroku 5. Następnie dokręć je przy użyciu klucza imbusowego. Rozpocznij od dwóch śrub na górze z obu stron, a następnie dokręć dwie dolne.

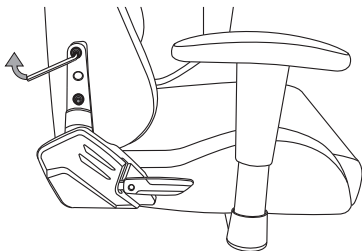

- 7 Zamocuj osłony boczne i przykręć je za pomocą śrub. (Osłony są oznaczone od wewnątrz „L” dla lewej strony i „R” dla prawej strony).

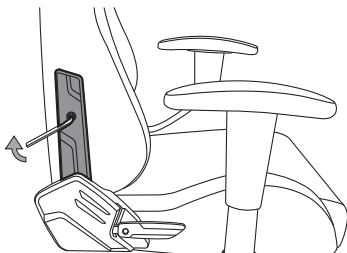

- 8 Następnie połóż fotel na oparciu. Wykręć ze spodu 4 wstępnie zamocowane śruby z podkładkami.

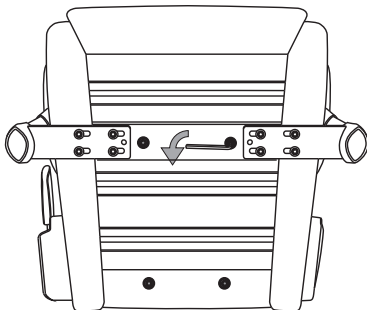

- 9 Powtórz powyższą czynność w celu instalacji modułu sterowania, a następnie umieść nakrętkę do montażu siłownika hydraulicznego w tylnej części siedziska (tam, gdzie zainstalowane jest oparcie).

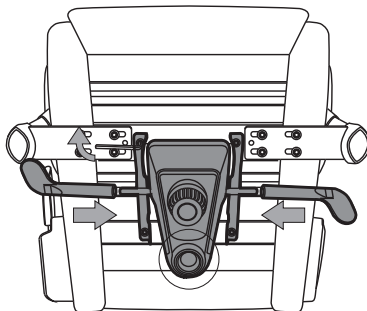

- 10 Włóż górną część siłownika hydraulicznego do otworu montażowego modułu sterowania, a następnie ustaw fotel w pozycji pionowej. (Ze względów bezpieczeństwa czynność ta musi zostać wykonana przez dwie osoby).

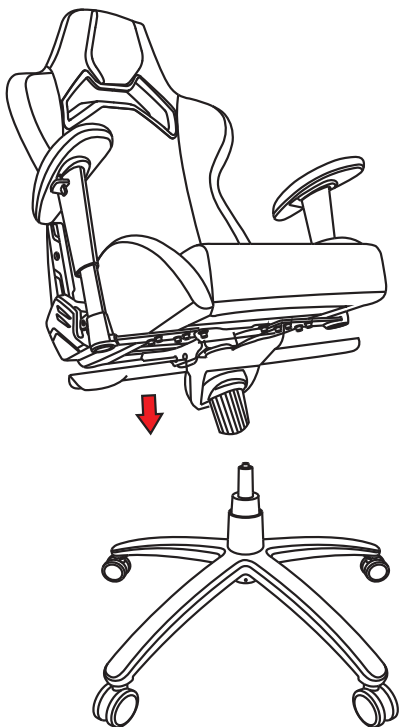

## Podświetlenie fotela

1. Włóż powerbanka do kieszeni z tyłu fotela.

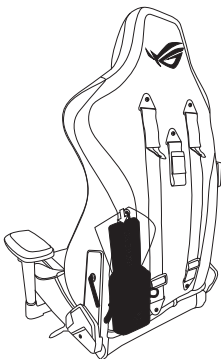

2. Podłącz złącze USB typu A do powerbanka.

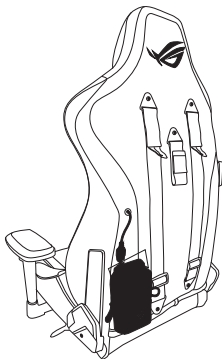

3. Kieszonka jest przymocowana do fotela na rzep. Można ją łatwo oderwać i zdjąć.

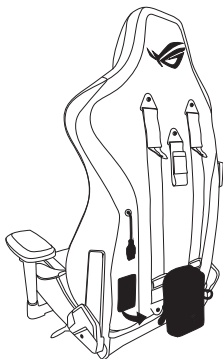

## D Inne właściwości

a

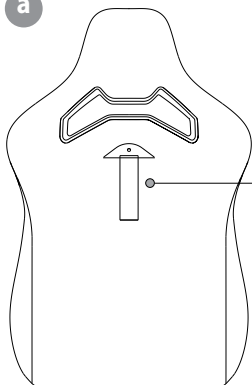

Wieszak z tyłu fotela do powieszenia torby, ubrania, kubka itp.  
Maksymalne obciążenie: 2 kg  
Nie wolno wieszać przedmiotów o wadze przekraczającej 2 kg.

## b Korzystanie z kontrolera RGB

Wartości znamionowe: 5V=1A

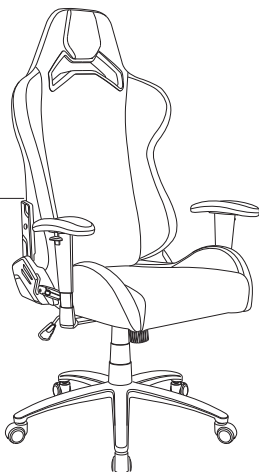
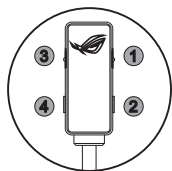

**NIE WOLNO** odłączać przymocowanego na stałe kontrolera, ponieważ unieważniłoby to gwarancję.

## 1. Podświetlenie Aura RGB: włączanie/efekt/wyłączenie

Naciśnij kilka razy w celu włączenia lub wyłączenia diod LED podświetlenia Aura RGB albo przełączenia między 7 dostępnymi efektami: (1) tęcza (2) oddychające (3) cykl kolorów (4) fala (5) świecące jojo (6) efekt stroboskopowy (7) światło statyczne

Naciśnij przycisk podświetlenia Aura RGB i przytrzymaj go przez 3 sekundy, aby wyłączyć podświetlenie.

Naciśnij ponownie, aby wznowić działanie lub podłącz ponownie powerbank, aby przywrócić ostatnie ustawienie.

**UWAGA:** Po wyłączeniu podświetlenia powerbank może automatycznie dostosować parametry wyjściowe. Należy odłączyć go i podłączyć ponownie, jeśli włączenie podświetlenia Aura RGB nie powoduje jego uaktywnienia.

## 2. Kolor podświetlenia Aura RGB

Naciśnij kilka razy w celu przełączenia następujących 8 imponujących kolorów: (1) czerwony (2) pomarańczowy (3) żółty (4) zielony (5) niebieski (6) Indygo (7) fioletowy (8) różowy

**UWAGA:** Funkcja ta jest dostępna tylko w przypadku poniższych efektów Aura RGB: (2) oddychające (6) efekt stroboskopowy (7) światło statyczne.

## 3. Szybkość podświetlenia Aura RGB: Wolno / Umiarkowanie / Szybko

Naciśnij kilka razy w celu przełączenia między 3 szybkościami kolorowych efektów: (1) Wolno (2) Umiarkowanie (3) Szybko

**UWAGA:** Funkcja ta jest dostępna tylko w przypadku poniższych efektów Aura RGB: (1) tęcza (2) oddychające (3) cykl kolorów (4) fala (5) świecące jojo (6) efekt stroboskopowy

## 4. Jasność podświetlenia Aura RGB: 50% / 75% / 100%

Dostępne są trzy poziomy jasności. Jasność można przełączyć za pomocą stuknięcia w celu dopasowania do oświetlenia otoczenia i własnych preferencji.

## 5. Przywracanie trybu fabrycznego

Naciśnij jednocześnie przyciski (2) i (4) w celu przywrócenia fabrycznych ustawień domyślnych fotela.

## E Funkcje regulacji

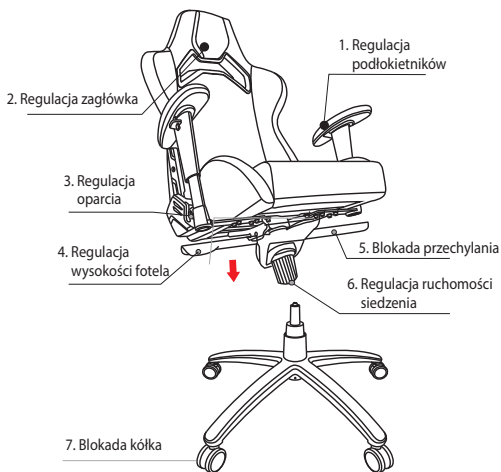

### 1. Regulacja podłokietników



1 Regulacja wysokości



2 Przesuwanie do przodu i do tyłu

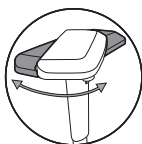

3 Regulacja obrotu



4 Przesuwanie do wewnątrz i na zewnątrz



## 2. Regulacja zagłówka

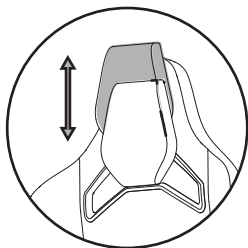

- Regulacja wysokości (6 cm)
- Nie wolno wyciągać zagłówka z nadmierną siłą.

## 3. Należy pociągnąć dźwignię w górę i powoli się oprzeć.

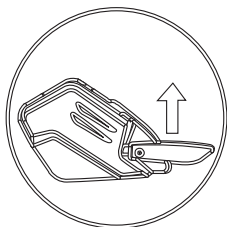

## 4. Regulacja wysokości fotela

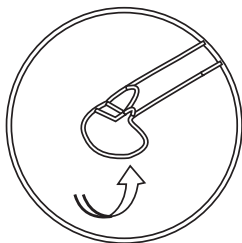

## 5. Blokada/odblokowanie mechanizmu przechylania

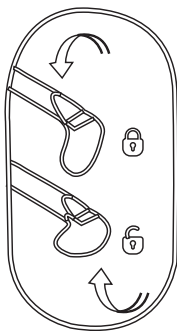

## 6. Regulacja ruchomości siedzenia

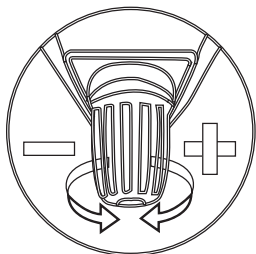

## 7. Blokada kółka

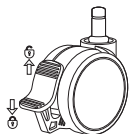

## Notificări de siguranță



- Stați în centrul scaunului, cu spatele lipit de spătar.



- Nu stați pe marginea scaunului.



- Nu stați în picioare pe scaun.



- Nu apăsați pe spătarul înclinat când o persoană se află pe el.



- Țineți mâinile și degetele la depărtare de mecanismul de înclinare.

## AVERTISMENT!

1. Acest scaun trebuie utilizat într-un mod normal și non-abuziv. Nu ne asumăm responsabilitatea pentru orice daune cauzate de asamblarea și/sau utilizarea necorespunzătoare.
2. Greutatea maximă recomandată este e 120 kg (264,5 lb).
3. Nu asamblați sau dezamblați niciodată scaunul într-un mod necorespunzător.
4. Vă rugăm să feriți scaunul de razele directe ale soarelui pentru a proteja pielea.
5. Vă rugăm să aveți grijă când spătarul revine în poziția originală din poziția înclinată.
6. Pentru a nu deteriora scaunul, nu utilizați forță excesivă pentru a ridica tetiera.
7. Nu încercați niciodată să deschideți și să atingeți modulul LED, întrucât veți anula astfel garanția.
8. Tensiunea de alimentare a acestui produs este de 5 V/1 A. Nu utilizați un adaptor de alimentare cu o tensiune mai mare de 5 V/3 A.

## A Conținutul ambalajului

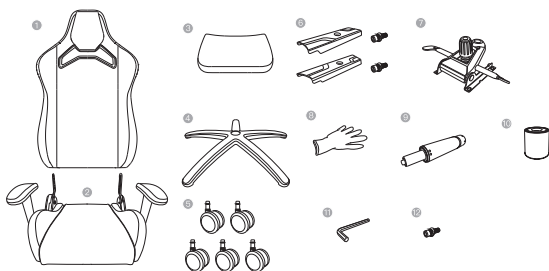

1.	Spătar	5.	Roți	9.	Cilindru hidraulic de ridicare
2.	Baza scaunului	6.	Capace laterale cu șuruburi	10.	Carcasă telescopică
3.	Pernă lombară	7.	Unitate de control	11.	Cheie hexagonală
4.	Baza roților	8.	Mănuși	12.	Șurub de schimb

**NOTĂ:** Ilustrațiile au doar rol exemplificativ și pot diferi de scaunul dvs. actual ca aspect și caracteristici.

## B Asamblarea scaunului

Puneți-vă mănușile înainte de instalare.

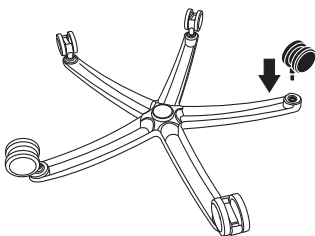

- 1 Pe rând, introduceți și împingeți roțile în bază.

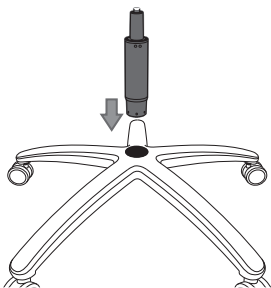

- 2 Introduceți cilindrul hidraulic de ridicare în orificiul din centrul bazei. Scoateți capacul roșu de protecție din vârf, dacă există.

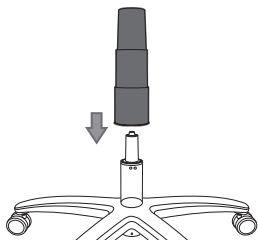

- 3 Puneți carcasa telescopică în vârful cilindrului hidraulic de ridicare

În mod normal, cotierele nu sunt diferite, cu excepția cazului în care se specifică altceva.

Pentru modelele cu cotiere pre-asamblare, vă rugăm să omiteți acest pas.

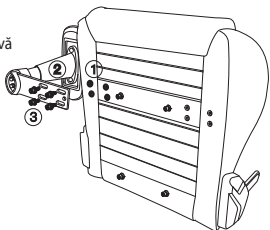

- 4 Scoateți șuruburile și șaibele pre-asamblate (1 & 3). Puneți cele 4 șaibe mari (1) între bara de montare a cotierelor (2) și baza scaunului. Țineți fixă cotiera, apoi introduceți și strângeți toate cele 4 șuruburi (3). Utilizați cheia hexagonală pentru a le strânge și repetați pe partea opusă.

- 5 Utilizați cheia hexagonală pentru a scoate toate șuruburile și șaibele pre-asamblate de pe spătar.

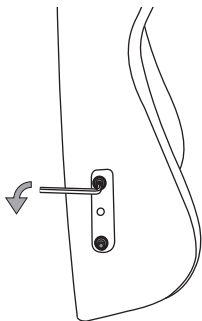

- 6 Scoateți ambalajele protectoare de spumă de pe suporturile bazei scaunului. Apoi, așezați spătarul cu grijă între suporturi. Introduceți și prindeți cele 4 șuruburi (câte 2 pe fiecare parte) pe care le-ați scos la pasul 5, mai întâi cu mâna. Apoi utilizați cheia hexagonală pentru a le strânge. Începeți cu cele două șuruburi din partea de sus pe fiecare parte, apoi continuați cu cele două din partea de jos.

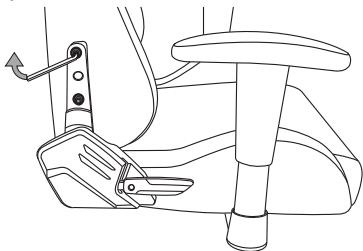

- 7 Instalați capacele laterale și strângeți șuruburile. (Capacele sunt marcate pe interior cu „L” pentru partea stângă și cu „R” pentru partea dreaptă.)

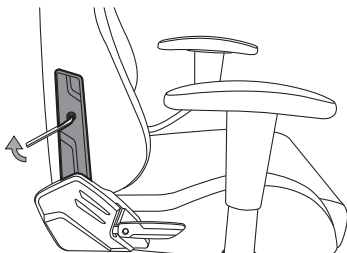

- 8 Acum întoarceți scaunul cu fața în jos. Apoi, scoateți cele 4 șuruburi și șaibele montate în prealabil de pe partea inferioară.

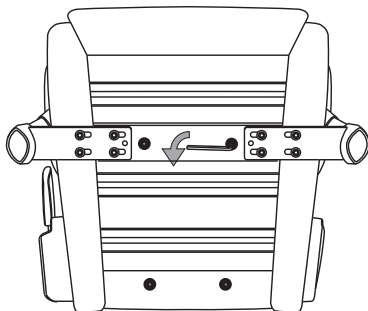

- 9 Repetați pasul de mai sus pentru a instala unitatea de control, apoi puneți piulița pentru a monta cilindrul hidraulic de ridicare cu fața spre spatele scaunului (unde este instalat spătarul).

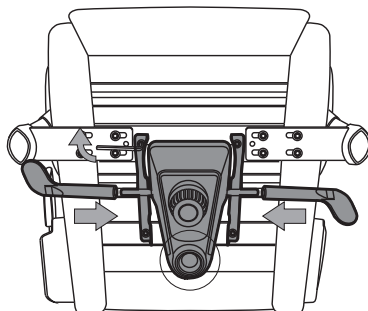

- 10 Introduceți vârful cilindrului hidraulic de ridicare în orificiul de montare de pe unitatea de control, apoi întoarceți scaunul în poziție verticală. (Pentru siguranța dvs. este necesar ca două persoane să manipuleze scaunul.)

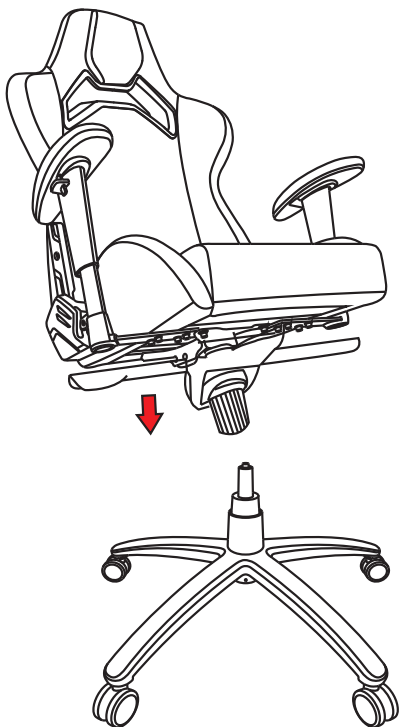



## **C** Iluminarea scaunului

1. Așezați bateria externă în pachetul din spatele scaunului

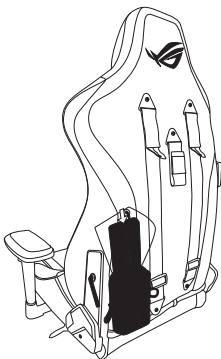

2. Conectați conectorul USB Type-A la bateria externă.

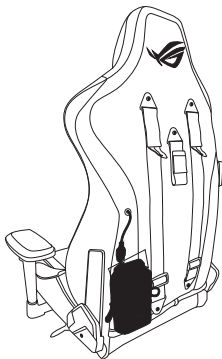

3. Pachetul este atașat pe scaun cu Velcro. Îl puteți îndepărta cu ușurință.

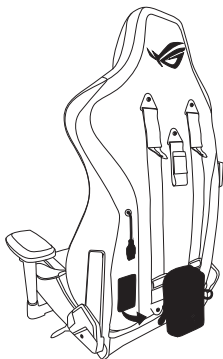

## D Alte caracteristici

a

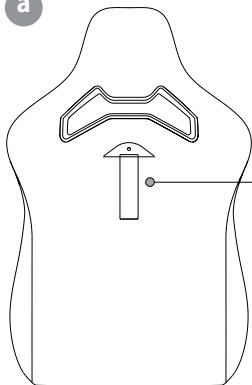

Cârlig în spatele scaunului pentru agățarea genților, hainelor, cănilor și multe altele.

Încărcătură maximă: 2 kg

Vă rugăm nu agățați obiecte cu greutate mai mare de 2 kg.

## b Utilizarea controlerului RGB

Tensiune: 5V=1A

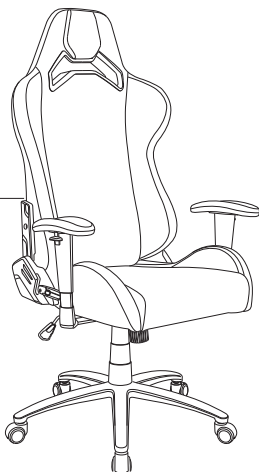
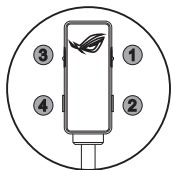

NU scoateți controlerul nedetașabil, întrucât veți anula astfel garanția.

1. Iluminare RGB Aura: Pornit/Efect/Oprit

Apăsați repetat pentru a porni sau a opri indicatoarele LED RGB Aura sau pentru a parcurge cele 7 efecte: (1) curcubeu (2) respirație (3) culoare ciclu (4) Val (5) Yo-Yo strălucitor (6) stroboscop (7) statică

Apăsați butonul de iluminare RGB Aura timp de 3 secunde pentru a opri iluminarea.

Apăsarea butonului pentru a porni din nou sau reconectarea bateriei va păstra setarea anterioară.

**NOTĂ:** Este posibil ca bateria externă să își ajusteze automat tensiunea când iluminarea este oprită. Deconectați și reconectați dacă Iluminarea RGB Aura nu se poate porni după ce ați comutat la pornire.

2. Culoare RGB Aura

Apăsați în mod repetat pentru a parcurge următoarele 8 culori surprinzătoare: (1) roșu (2) portocaliu (3) galben (4) verde (5) albastru (6) indigo (7) violet (8) roz

**NOTĂ:** Această funcție este disponibilă doar pentru următoarele efecte Aura RGB: (2) respirație (6) stroboscop (7) statică

3. Viteza RGB Aura: Încet/Mediu/Rapid

Apăsați în mod repetat pentru a parcurge următoarele 3 viteze ale efectelor de culoare:: (1) Încet (2) Mediu (3) Rapid

**NOTĂ:** Această funcție este disponibilă doar pentru următoarele efecte Aura RGB: (1) curcubeu (2) respirație (3) culoare ciclu (4) Val (5) Yo-Yo strălucitor (6) stroboscop

4. Luminositate RGB Aura: 50% / 75% / 100%

Trei niveluri de luminositate. Luminositatea poate fi comutată printr-o singură atingere pentru a se adapta la lumina mediului și la preferințe.

5. Reinițializare la setările implicite din fabrică

Apăsați simultan butonul (2) și butonul (4) pentru a reinițializa scaunul la setările implicite din fabrică.

## E Funcții reglabile

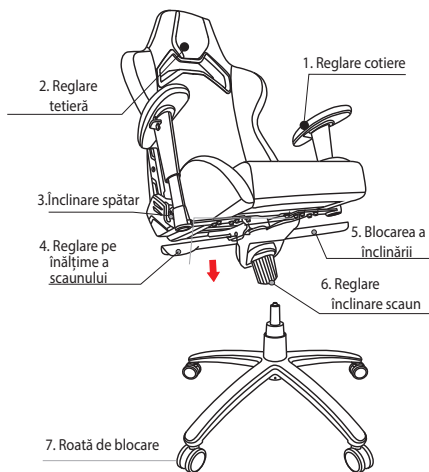

### 1. Reglare cotiere



## 2. Reglare tetieră

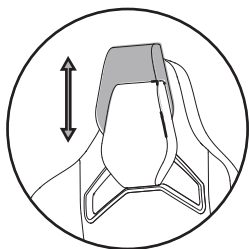

- Reglare pe înălțime (6 cm)
- Vă rugăm nu ridicați excesiv tetiera.

## 3. Trageți de mâner și lăsați-vă ușor pe spate

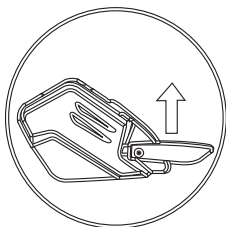

## 4. Reglare pe înălțime a scaunului

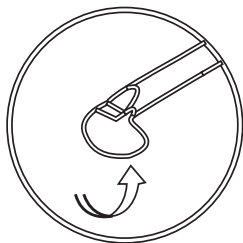

## 5. Blocați/deblocați mecanismul de înclinare

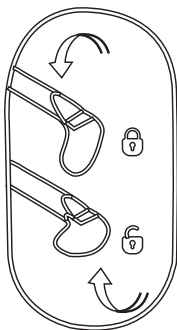

## 6. Reglare înclinare scaun

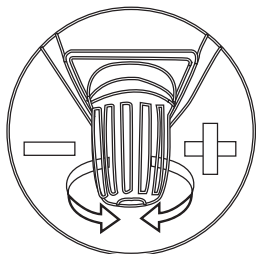

## 7. Roată de blocare

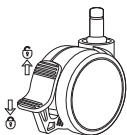

## Avisos de seguridad



- Siéntese en el centro de la silla con su espalda apoyada en el respaldo.



- No se siente en el borde de la silla.



- No se ponga de pie sobre la silla.



- No empuje el respaldo reclinado cuando haya una persona apoyada sobre este.



- Mantenga sus manos alejadas del mecanismo del respaldo.

## ADVERTENCIA!

1. Esta silla debe utilizarse de manera habitual y no abusiva. No asumimos la responsabilidad de cualquier daño derivado de un montaje o uso indebidos.
2. La carga de peso máxima recomendada es de 120 kg (264.5 libras).
3. Nunca realice el montaje o desmontaje de su silla de forma inadecuada.
4. Mantenga la silla lejos del contacto directo con la luz solar para proteger su material de piel.
5. Tenga cuidado con su espalda cuando el respaldo vuelva a su posición original después de haber estado reclinado.
6. Para evitar daños a su silla, no ejerza una fuerza excesiva para levantar el reposacabezas.
7. Nunca abra y toque el módulo de LED, ya que esto anulará la garantía.
8. El valor nominal de entrada de alimentación de este producto es de 5 V/1 A. No utilice un adaptador de alimentación con una salida superior a 5 V/3 A.



## A Contenido del paquete

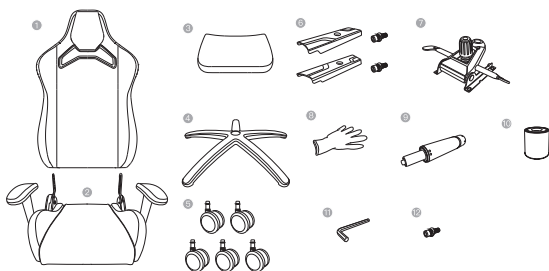

1.	Respaldo	5.	Ruedas	9.	Cilindro de elevación hidráulica
2.	Base del asiento	6.	Cubiertas laterales con tornillos	10.	Tapa telescópica
3.	Cojín lumbar	7.	Unidad de control	11.	Llave Allen
4.	Base de la rueda	8.	Guantes	12.	Tornillo de repuesto

**Nota:** Las ilustraciones son solo de referencia y pueden variar de la silla real en cuanto a apariencia y características.

## B Ensamblaje de la silla

Póngase los guantes antes de realizar la instalación.

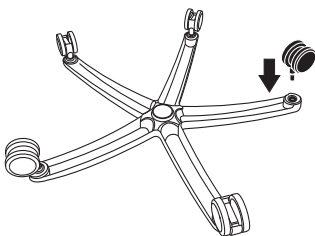

- 1 Inserte y empuje la ruedas en la base una a una.

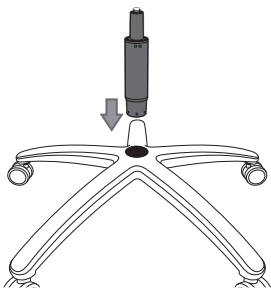

- 2 Inserte el cilindro de elevación hidráulica en el orificio central de la base. Quite la cubierta protectora roja de la parte superior si había alguna.

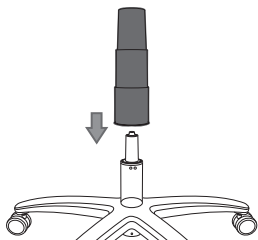

- 3 Coloque la cubierta telescópica en la parte superior del cilindro de elevación hidráulica.

A menos que se indique lo contrario mediante alguna etiqueta, los apoyabrazos valen para cualquiera de los lados.

Para modelos con apoyabrazos preinstalado, omita este paso.

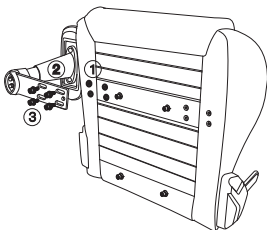

- 4 Quite los tornillos y las arandelas previamente ensamblados (1 y 3). Coloque las 4 arandelas grandes (1) entre la barra de montaje del apoyabrazos (2) y la base del asiento. Mantenga el apoyabrazos en su lugar y, a continuación, inserte y apriete los 4 tornillos (3). Utilice la llave Allen para apretarlos todos y repita estos pasos en el otro lado.

- 5 Utilice la llave Allen para quitar los tornillos y las arandelas previamente ensamblados del apoyabrazos.

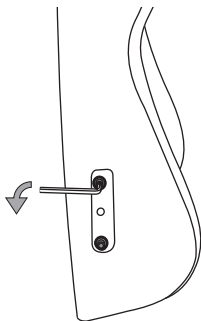

- 6 Quite las cubiertas de espuma de protección de los soportes de la base del asiento. A continuación, coloque el apoyabrazos con cuidado entre los soportes. En primer lugar, inserte y acople los 4 tornillos (2 en cada lado) que quitó en el paso 5 a mano. A continuación, utilice la llave Allen para apretarlos. Comience con los dos tornillos de la parte superior de cada lado y, a continuación, con los dos inferiores.

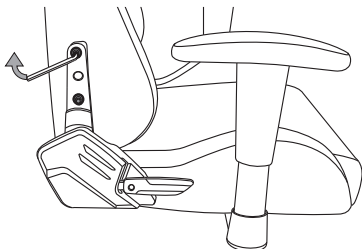

- 7 Instale las cubiertas laterales y apriete los tornillos. (Las cubiertas están marcadas con "L" para el lado izquierdo y "R" para el lado derecho).

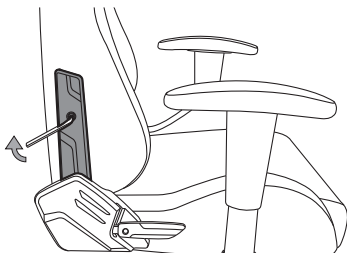

- 8 Ahora voltee la silla, y póngala boca abajo. Después, quite los 4 tornillos previamente instalados de la parte inferior con las arandelas.

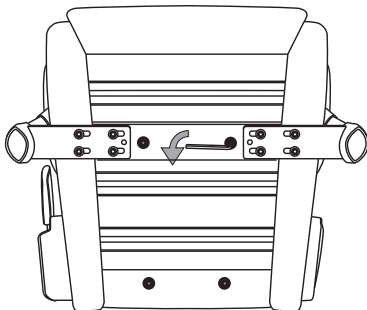

- 9 Repita el paso anterior para instalar la unidad de control y, a continuación, coloque la tuerca para montar el cilindro de elevación hidráulica orientado hacia la parte trasera del asiento (donde se instala el respaldo).

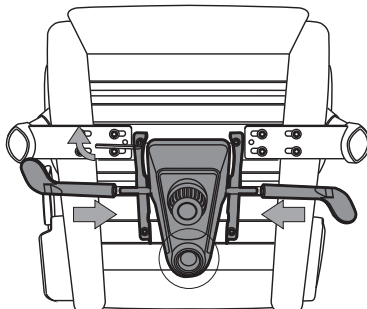

- 10 Inserte la parte superior del cilindro de elevación hidráulica en el orificio de instalación de la unidad de control y, a continuación, gire la silla en posición vertical. (Por su seguridad, se necesitan dos personas para manipular el producto)

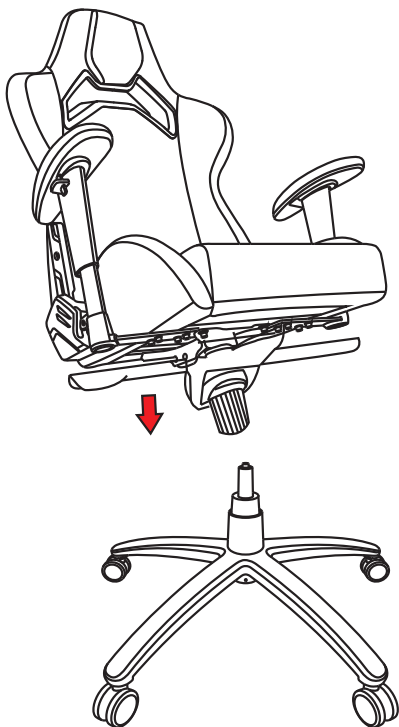

## **C** Iluminar la silla

1. Coloque la batería externa en un bolsillo en la parte posterior de la silla.

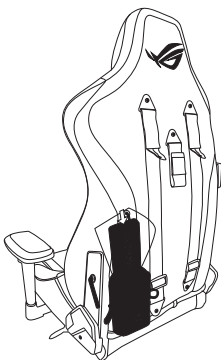

2. Enchufe el conector USB Tipo-A a la batería externa.

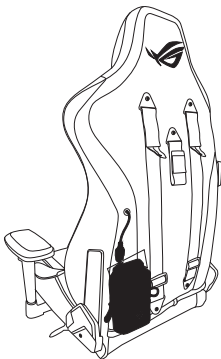

3. El bolsillo está acoplado a la silla con Velcro. Puede quitarlo y retirarlo fácilmente.

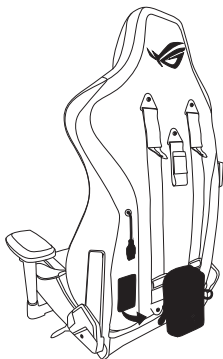

## D Otras características

a

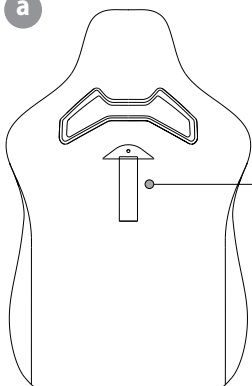

Gancho en la parte posterior de la silla para colgar sus bolsas, ropas, tazas y mucho más.

Carga máxima: 2 kg

No cuelgue objetos que excedan los 2 kg.

## b Utilizar el controlador RGB

Valores nominales: 5V=1A

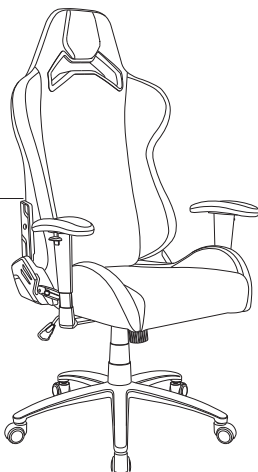
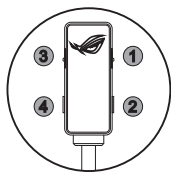

NO quite el controlador no desmontable ya que, si lo hace, anulará la garantía.



## 1. Iluminación Aura RGB: Activa/Efecto/Desactivada

Presione repetidamente para encender o apagar los LED Aura RGB, o recorrer cíclicamente los 7 efectos actuales: (1) arco iris (2) respiración (3) ciclo de colores (4) onda (5) yoyó resplandeciente (6) estroboscópico (7) estático

Presione el botón Iluminación Aura RGB durante 3 segundos para dar fin a la iluminación.

Presiónelo para volver a reactivarlo o vuelva a conectar la batería externa para mantener su configuración anterior.

**NOTA:** La batería externa puede ajustar automáticamente la salida cuando se termina la iluminación. Desconéctela y vuelva a conectarla si la iluminación Aura RGB no se puede reactivar después de volverla a activar.

## 2. Color Aura RGB

Presione repetidamente para recorrer los siguientes ocho colores llamativos: (1) rojo (2) naranja (3) amarillo (4) verde (5) azul (6) Añil (7) púrpura (8) rosa

**NOTA:** Esta función solo está disponible en los siguientes efectos de Aura RGB - (2) respiración (6) estroboscópico (7) estático.

## 3. Velocidad Aura RGB: Lenta/Media/Rápida

Presione repetidamente para recorrer las siguientes 3 velocidades de efecto de color: (1) Lenta (2) Media (3) Rápida

**NOTA:** Esta función solo está disponible en los siguientes efectos de Aura RGB - (1) arco iris (2) respiración (3) ciclo de colores (4) onda (5) yoyó resplandeciente (6) estroboscópico

## 4. Brillo Aura RGB: 50% / 75% / 100%

Tres niveles de brillo. El brillo se puede cambiar simplemente pulsando para ajustar la luz de fondo y las preferencias.

## 5. Restablecer el modo de fábrica

Presione el botón (2) y el botón (4) simultáneamente para restablecer los valores predeterminados de fábrica de la silla.

## **E** Funciones ajustables

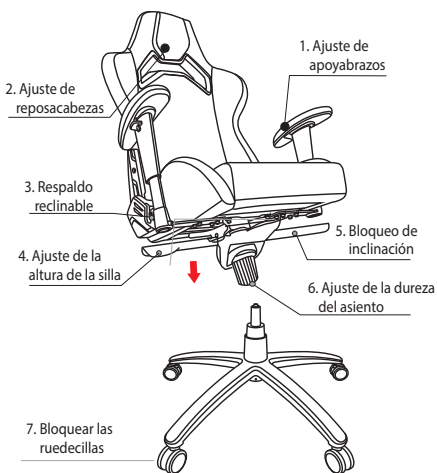

### **1. Ajuste de apoyabrazos**

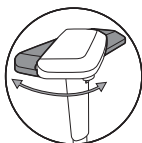

## 2. Ajuste de reposacabezas

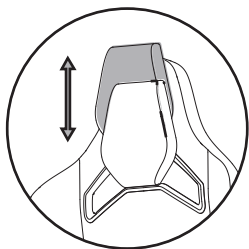

- Ajuste de altura (6 cm)
- No eleve demasiado su reposacabezas.

## 3. Levante la palanca e inclínese poco a poco hacia atrás.

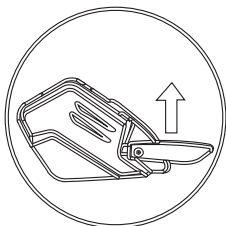

## 4. Ajuste de la altura de la silla

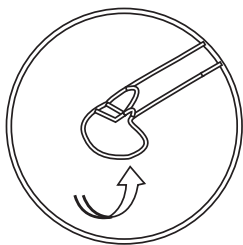

## 5. Bloquee/desbloquee el mecanismo de inclinación

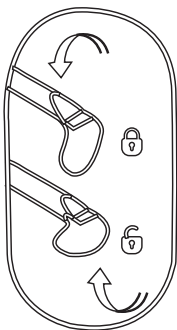

## 6. Ajuste de la dureza del asiento

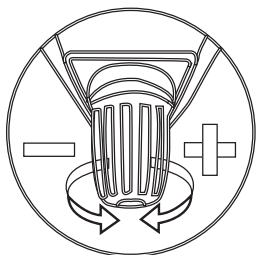

## 7. Bloquear las ruedecillas

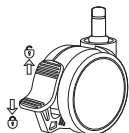

## Bezpečnostné informácie



- Sedte v strede stoličky s chrbtom opretými o operadlo.



- Neseďte na okraji stoličky.



- Nestojte na stoličke.



- Netlačte na operadlo, keď je oň opretá osoba.



- Ruky a prsty si nekladajte do sklápacieho mechanizmu.

## VÝSTRAHA!

1. Táto stolička sa musí používať len normálnym a šetrným spôsobom. Nezodpovedáme za žiadne škody vyplývajúce z nesprávneho zmontovania a/alebo používania.
2. Maximálne odporúčanie zaťaženie je 120 kg (264,5 libier).
3. Stoličku nikdy nemontujte ani nerozoberajte nesprávnym spôsobom.
4. Stoličku uchovávajte na mieste mimo priameho slnečného svetla, aby bol chránený jej kožený poťah.
5. Pri návrate operadla do svojej pôvodnej polohy zo sklopenej polohy dávajte pozor na svoj chrbát.
6. Opierku hlavy nevyťahujte nadmernou silou, aby ste nepoškodili stoličku.
7. Nikdy sa nepokúšajte otvárať modul LED, pretože tým dôjde k skončeniu platnosti záruky.
8. Pre tento výrobok je menovitý vstupný výkon 5 V/1 A. Nepoužívajte sieťový adaptér s výkonom vyšším ako 5 V/3 A.

## A Obsah balenia

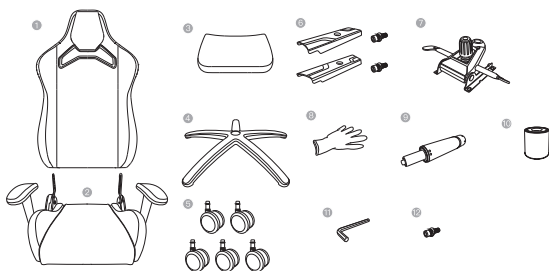

1.	Operadlo	5.	Kolieska	9.	Hydraulický zdvíhací valec
2.	Základňa sedadla	6.	Bočné kryty so skrutkami	10.	Teleskopický kryt
3.	Bederná opierka chrbta	7.	Regulátor	11.	Imbusový kľúč
4.	Základňa na kolieskach	8.	Rukavice	12.	Náhradná skrutka

**Poznámka :** Obrázky sú len ilustračné a môžu sa líšiť od vzhľadu a funkcií vašej skutočnej sloičky.

## B Zmontovanie stoličky

Pred inštaláciou si nasadte rukavice.

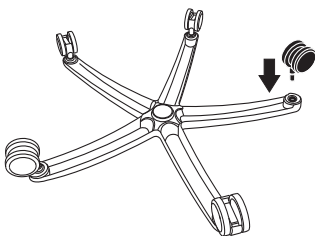

- 1 Koleska postupne zatlačajte do základne.

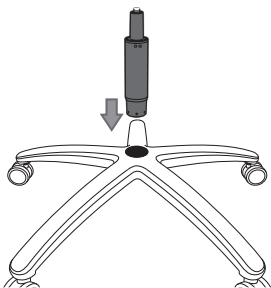

- 2 Hydraulický zdvíhací valec vložte do stredného otvoru v základni. Z hornej časti odstráňte červené ochranné viečko, ak sa používa.

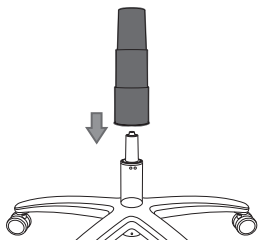

- 3 Teleskopické krytky založte na hornú časť hydraulického zdvíhacieho valca.

Strany laktových opierok sa zvyčajne nerozlišujú, pokiaľ nie je označené ináč.

Tento krok vynechajte v prípade modelov s vopred namontovanými laktovými opierkami.

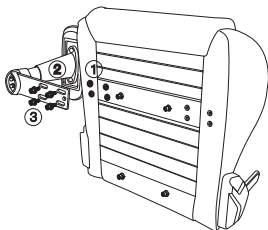

- 4 Odstráňte vopred naskrutkované skrutky a podložky (1) a (3). Medzi montážnu lištu (2) a základňu sedadla vložte 4 veľké podložky (1). Laktovú opierku podržte na mieste a vložte a utiahnite všetky 4 skrutky (3). Všetky utiahnite pomocou imbusového kľúča a tento postup zopakujte na druhej strane.

- 5 Z operadla odskrutkujte pomocou imbusového kľúča vopred naskrutkované skrutky s podložkami.

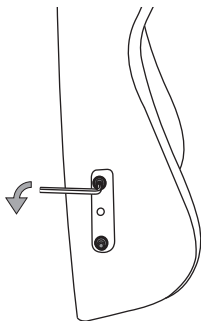

- 6 Z konzol základne sedadla odstráňte ochranné penové kryty. Potom operadlo opatrne umiestnite medzi konzoly. Vložte a najskôr rukou utiahnite 4 skrutky (2 na každej strane), ktoré ste v 5. kroku vyskrutkovali. Potom ich utiahnite pomocou imbusového kľúča. Začnite s dvoma skrutkami na vrchu každej strany a potom utiahnite dve spodné skrutky.

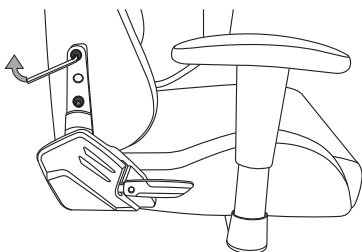



- 7 Namontujte bočné kryty a utiahnite skrutky. (Kryty sú označené písmenom „L“ pre ľavú stranu a písmenom „R“ pre pravú stranu.)

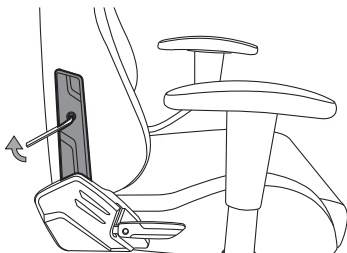

- 8 Teraz sedadlo preklopte hornou stranou nadol. Zo spodnej strany odskrutkujte 4 vopred naskrutkované skrutky spolu s podložkami.

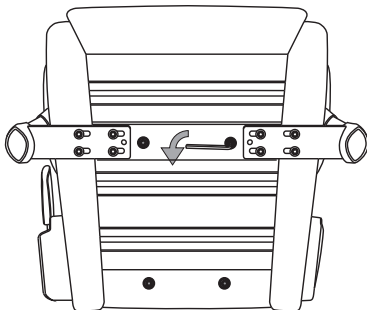

- 9 Regulátor namontujte zopakovaním vyššie uvedeného kroku a maticou upevnite hydraulický zdvihací valec smerom k zadnej časti sedadla (miesto, kde je namontované operadlo).

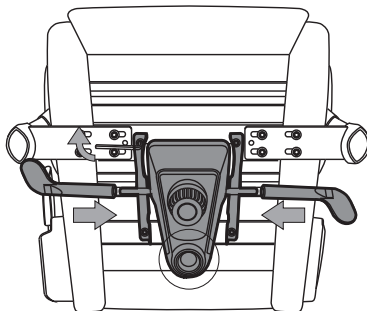

- 10 Hornú časť hydraulického zdvihadieho valca vložte do montážneho otvoru v regulátore a potom sedadlo otočte do vzpriamenej polohy. (Z bezpečnostných dôvodov sú pri manipulácii potrebné dve osoby)

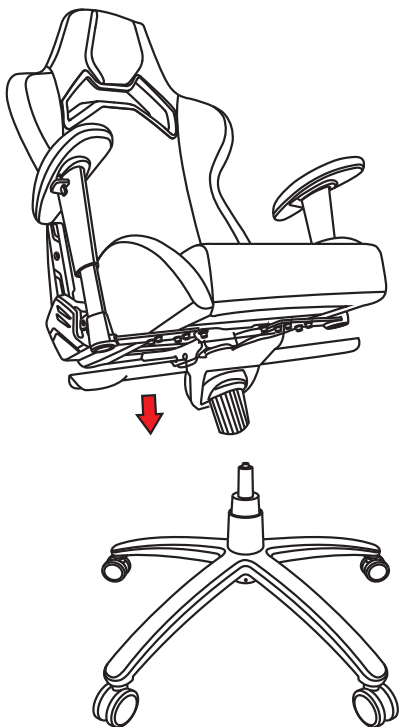

## Osvetlenie stoličky

1. Napájací zdroj Power Bank vložte do priehradky na zadnej strane stoličky.

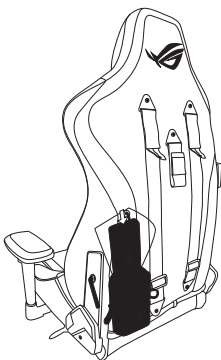

2. Konektor USB Type-A pripojte do zdroja Power Bank.

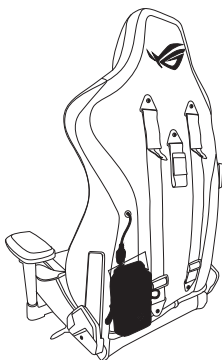

3. Priehradka je upevnená k stoličke pomocou suchého zipsu. Môžete ju ľahko odpojiť a odobrať.

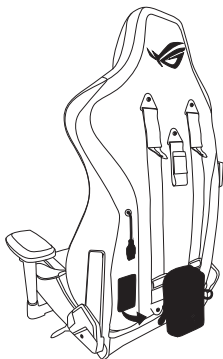

## D Ďalšie funkcie

a

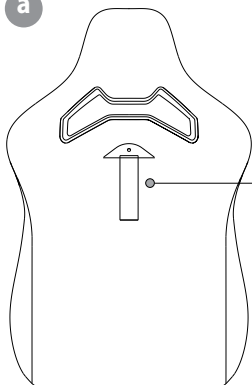

Háčik na zadnej strane stoličky, na ktorý si môžete zavesiť tašky, oblečenie, šálky a viac.

Maximálne zaťaženie: 2 kg

Nevešajte predmety s hmotnosťou viac ako 2 kg.

## b Používanie riadiacej jednotky RGB

Menovitý výkon: 5V=1A

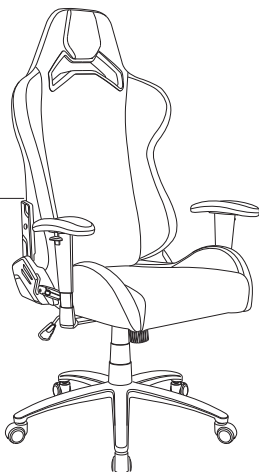
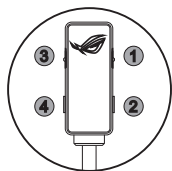

Neodpojteľnú riadiacu jednotku NEVYBERAJTE, pretože tým dôjde k skončeniu platnosti záruky.

- Osvetlenie Aura RGB: Zapnúť/ Efekt/Vypnúť**

Ak chcete kontrolky LED Aura RGB zapnúť alebo vypnúť, opakovane stlačte toto tlačidlo alebo prepínajte medzi 7 efektmi prúdu: (1) dúha (2) vetranie (3) farba cyklus (4) vlna (5) striedavé svietenie (Yo-Yo) (6) rozjasňovač (7) statický

Ak chcete osvetlenie vypnúť, stlačte tlačidlo Aura RGB a podržte ho stlačené na 3 sekundy.

Stlačením tohto tlačidla ho prebudíte alebo opätovným pripojením zdroja napájania Power Bank si zachová predchádzajúce nastavenie.

**POZNÁMKA:** Zdroj napájania Power Bank môže po vypnutí osvetlenia automaticky nastaviť svoj výstup. Ak sa osvetlenie Aura RGB nedá zobudiť po opätovnom zapnutí, odpojte ho a znova pripojte.
- Farby Aura RGB**

Opakovaným stláčaním môžete prepínať medzi 8 pozoruhodnými farbami: (1) červený (2) oranžový (3) žltý (4) zelený (5) modrý (6) Indigová (7) fialový (8) ružový

**POZNÁMKA:** Táto funkcia je k dispozícii len pri týchto efektoch Aura RGB: (2) vetranie (6) rozjasňovač (7) statický
- Rýchlosť Aura RGB: Pomalá/Stredná/Vysoká**

Opakovaným stláčaním môžete prepínať medzi týmito 3 rýchlosťami farebných efektov: (1) Pomalá (2) Stredná (3) Vysoká

**POZNÁMKA:** Táto funkcia je k dispozícii len pri týchto efektoch Aura RGB: (1) dúha (2) vetranie (3) farba cyklus (4) vlna (5) striedavé svietenie (Yo-Yo) (6) rozjasňovač
- Jas Aura RGB: 50% / 75% / 100%**

Tri úrovne jasu. Jas môžete zapnúť jednoduchým ťuknutím tak, aby vyhovoval osvetleniu prostredia a výkonu.
- Obnoviť nastavenia z výroby**

Súčasným stlačením tlačidla (2) a tlačidla (4) obnovíte predvolené výrobné nastavenia stoličky.

## E Nastavitelné funkcie

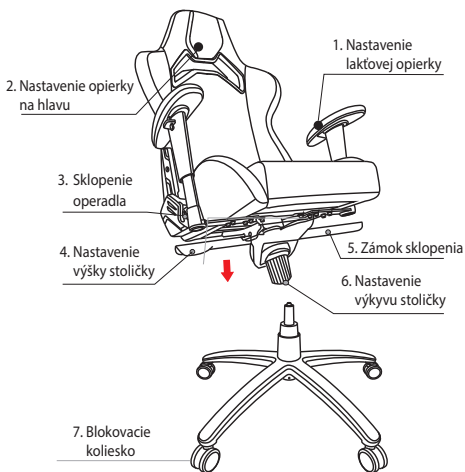

### 1. Nastavenie laktovej opierky

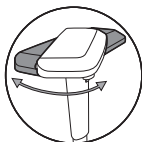

## 2. Nastavenie opierky na hlavu

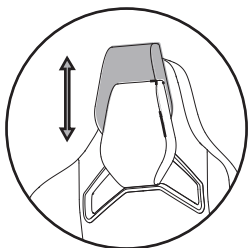

- Nastavenie výšky (6 cm)
- Opierku nezdvíhajte nadmerne vysoko.

## 3. Potiahnite páčku a pomaly sa nakláňajte dozadu

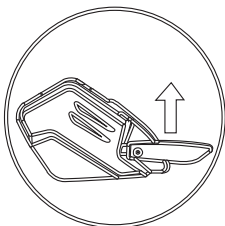

## 4. Nastavenie výšky stoličky

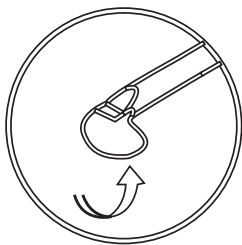

## 5. Zaistiť/odistiť sklápací mechanizmus

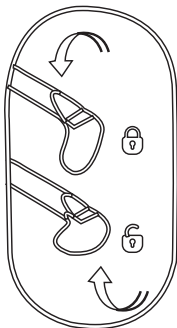



## 6. Nastavenie výkyvu stoličky

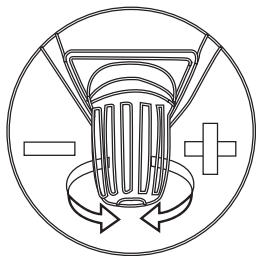

## 7. Blokovacie koliesko

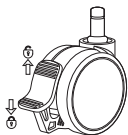

## Güvenlik Bildirimleri



- Sırtınız arkalığa dayanacak şekilde sandalyenin merkezinde oturun.



- Sandalyenin kenarına oturmayın.



- Sandalyenin üzerinde ayakta durmayın.



- Sandalyeye biri yaslanmışken, arkalığı aşağı doğru bastırmayın.



- Ellerinizi ve parmaklarınızı yaslama mekanizmasından uzak tutun.

## UYARI!

1. Bu sandalye normal bir şekilde kullanılmalı, hor kullanılmamalıdır. Hatalı montaj ve/veya kullanımdan kaynaklanan hiçbir hasardan sorumlu değiliz.
2. Tavsiye edilen maksimum ağırlık yükü 120 KG'dır.
3. Sandalyenizi asla hatalı şekilde monte etmeyin veya sökmeyin.
4. Derisini korumak için lütfen sandalyenizi direkt güneş ışığından uzak tutun.
5. Arkalık tekrar normal pozisyonuna dönerken lütfen sırtınıza dikkat edin.
6. Sandalyeye zarar gelmemesi için, lütfen baş desteğinizi yukarı çekmek için aşırı güç kullanmayın.
7. Garantiyi geçersiz kılacağından, LED modülünü asla açmaya ve modüle dokunmaya çalışmayın.
8. Bu ürün için güç girişi kademesi 5V/1A'dır. Çıkış değeri 5V/3A'dan yüksek bir güç adaptörü kullanmayın.

## A

## Paket içeriđi

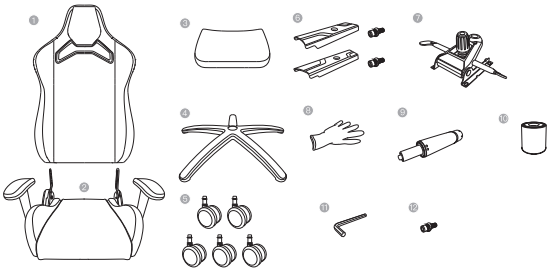

1.	Arkalık	5.	Tekerlekler	9.	Hidrolik kaldırma silindiri
2.	Sandalye tabanı	6.	Cıvatalı yan kapaklar	10.	Teleskop kapađı
3.	Bel minderi	7.	Kontrol ünitesi	11.	Altıgen Anahtar
4.	Tekerlek tabanı	8.	Eldivenler	12.	Yedek cıvata

**Not:** Resimler yalnızca referans içindir ve görünüm ve özellikler bakımından gerçek sandalyenizden farklı olabilir.

## B Sandalyenizin montajı

Kurulumdan önce eldivenleri takın.

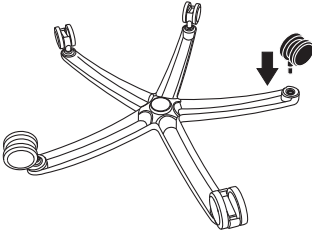

- 1 Teker teker, tekerlekleri tabana yerleştirin ve itin.

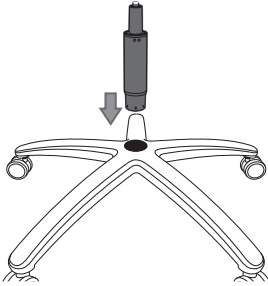

- 2 Hidrolik kaldırma silindirini tabanın ortasındaki deliğe yerleştirin. Varsa üstteki kırmızı koruyucu kapağı çıkarın.

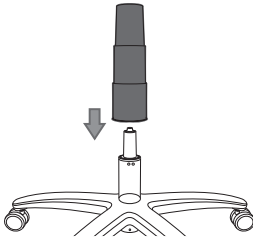

- 3 Teleskop kapağını hidrolik kaldırma silindirinin üstüne yerleştirin.

Aksi belirtilmediği sürece, kolçakların sağ ve sol tarafı fark etmez.

Kolçağı önceden monte edilmiş modeller için, lütfen bu adımı atlayın.

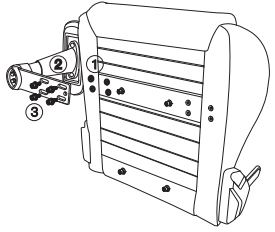

- 4 Önceden monte edilmiş cıvataları ve rondelaları (1) ve (3). sökün. 4 büyük rondelayı (1) kolçak montaj çubuğu (2) ile koltuk tabanı arasına yerleştirin. Kol dayanağını yerinde sabit tutun, ardından 4 cıvatayı (3) takın ve sıkın. Altıgen anahtarı kullanarak hepsini sıkın ve diğer tarafta işlemi tekrar edin.

- 5 Altıgen anahtarı kullanarak önceden monte edilmiş cıvataları ve rondelaları sandalyenin arkalığında çıkarın.

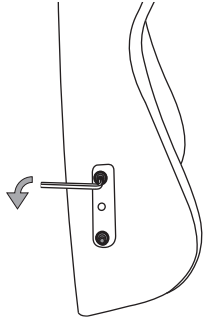

- 6 Koruyucu köpük kapaklarını sandalye tabanı braketlerinden çıkarın. Ardından arkalıği dikkatlice braketlerin arasına yerleştirin. Önce 5. adımda çıkardığınız 4 cıvatayı (her iki tarafta 2 adet) elinizle takın ve sabitleyin. Sonra altıgen anahtarı kullanarak bunları sıkın. Her iki tarafın üst kısmındaki iki cıvata ile başlayın, ardından alttaki ikisine geçin.

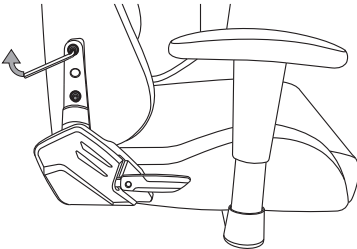

- 7 Yan kapakları takın ve cıvataları sıkın. (Kapaklar içerde sol taraf için "L" ve sağ taraf için "R" ile işaretlenmiştir.)

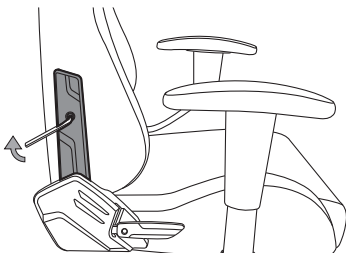

- 8 Şimdi sandalyeyi aşağıya bakacak şekilde ters çevirin. Ardından, önceden monte edilmiş 4 cıvatayı pullarla birlikte alttan çıkarın.

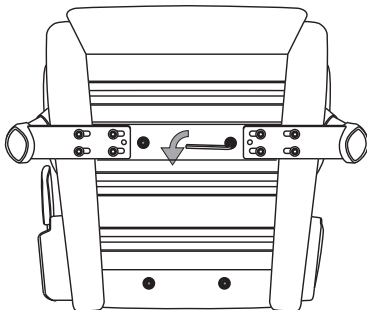

- 9 Kontrol ünitesini takmak için yukarıdaki adımı tekrarlayın ve ardından hidrolik kaldırma silindirini sandalyenin arkasına bakacak şekilde (arkalığın takılı olduğu yere) monte etmek için somunu yerleştirin.

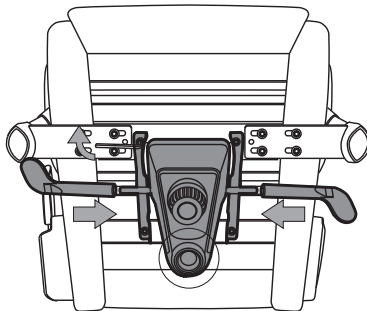

- 10 Hidrolik kaldırma silindirin üst kısmını kontrol ünitesindeki montaj deliğine yerleştirin ve ardından sandalyeyi dik konuma çevirin. (Güvenliğiniz için iki kişi tutmalıdır)

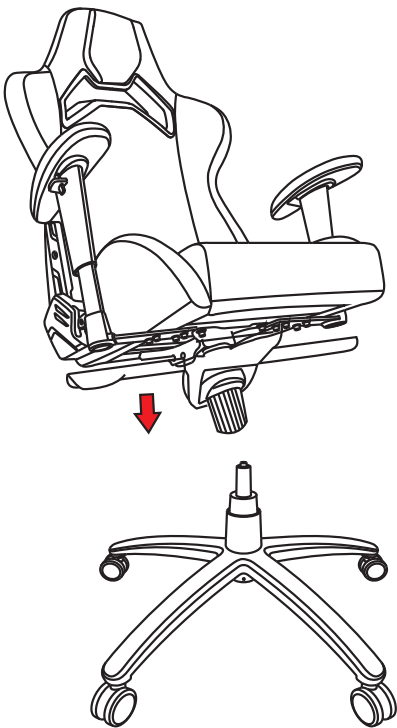

## Sandalyenizi aydınlatın

1. Güç bankanızı sandalyenin arkasındaki cebe yerleştirin.

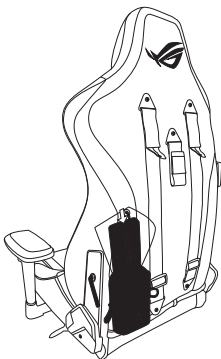

2. USB Tip-A konektörü güç bankınıza takın.

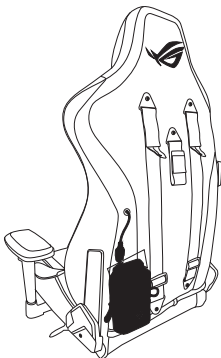



3. Cep sandalyenize Velcro ile tutturulmuştur Kolayca çıkarıp götürebilirsiniz.

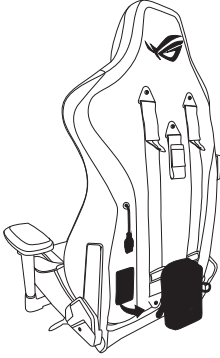

## D Diğer özellikler

a

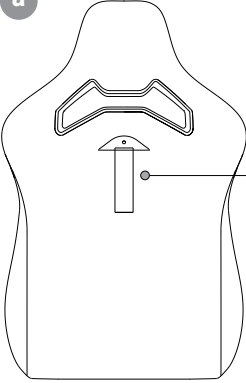

Sandalyenin arkasındaki askı çantalarınızı, kıyafetlerinizi, bardaklarınızı ve daha fazlasını asmak içindir.  
Maksimum yük: 2kg  
Lütfen 2kg'dan fazla eşya asmayın.

## b RGB denetleyiciyi kullanma

Kademe: 5V=1A

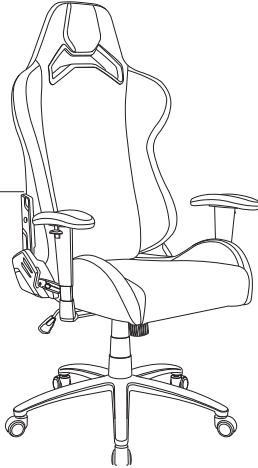
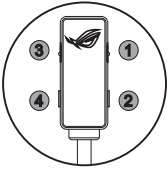

Garantiyi geçersiz kılacağından, sökülemez kumandayı ÇIKARMAYIN.

1. Aura RGB Aydınlatma: Açık / Efekt / Kapalı  
Aura RGB LED'leri açmak veya kapatmak ya da mevcut 7 efekt arasında geçiş yapmak için arka arkaya basın: (1) gökkuşağı (2) nefes alma (3) renk döngüsü (4) dalga (5) Yanan Yo-Yo (6) yanıp sönme (7) statik  
Aydınlatmayı sonlandırmak için Aura RGB Aydınlatma düğmesine 3 saniye basın.  
Tekrar uyandırmak için basın veya güç bankanızı yeniden taktığınızda önceki ayarlar korunacaktır.  
**NOT:** Aydınlatma sonlandırıldığında powerbank'ınız çıkışını otomatik olarak ayarlayabilir. Aura RGB Aydınlatması siz tekrar açtıktan sonra uyanamazsa, bağlantısını kesip tekrar takın.
2. Aura RGB rengi  
Aşağıdaki 8 çarpıcı renk arasında geçiş yapmak için art arda basın: (1) kırmızı (2) turuncu (3) sarı (4) yeşil (5) mavi (6) Indigo (7) mor (8) pembe  
**NOT:** Bu özellik yalnızca aşağıdaki Aura RGB efektlerinde kullanılabilir - (2) nefes alma (6) yanıp sönme (7) statik.
3. Aura RGB hızı: Yavaş / Orta / Hızlı  
Aşağıdaki 3 renk efekti hızları arasında geçiş yapmak için art arda basın: (1) Yavaş (2) Orta (3) Hızlı  
**NOT:** Bu özellik yalnızca aşağıdaki Aura RGB efektlerinde kullanılabilir - (1) gökkuşağı (2) nefes alma (3) renk döngüsü (4) dalga (5) Yanan Yo-Yo (6) yanıp sönme.
4. Aura RGB parlaklığı: 50% / 75% / 100%  
Üç parlaklık seviyesi. Parlaklık, basit bir dokunuşla ortam aydınlatmasına ve tercihine uyacak şekilde değiştirilebilir.
5. Fabrika moduna sıfırlama  
Sandalyenizi fabrika ayarlarına döndürmek için aynı anda (2) ve (4) nolu düğmelere basın.

## E Ayarlanabilir işlevler

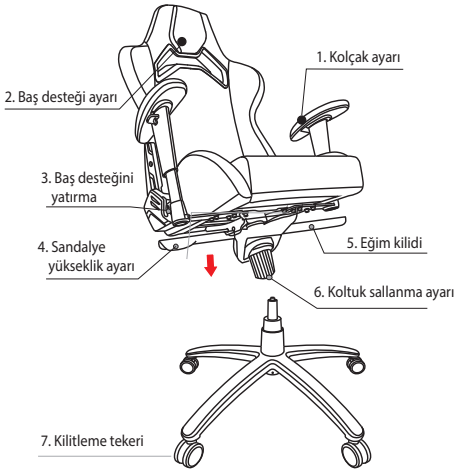

### 1. Kolçak ayarı

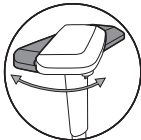

## 2. Bař desteęi ayarı

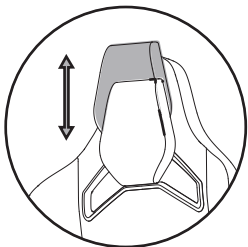

- Ykseklik ayarı (6cm)
- Ltfen bař desteęinizi ok fazla ykseltmeyin.

## 3. Kolu ekin ve yavařa arkaya yaslanın.

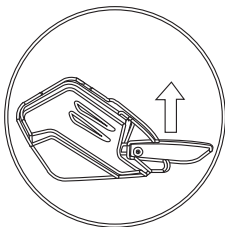

## 4. Sandalye ykseklik ayarı

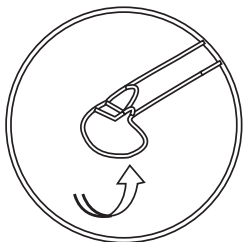

## 5. Eęme mekanizması kilitleme/ama

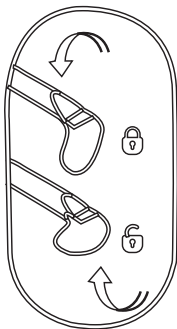

## 6. Koltuk sallanma ayarı

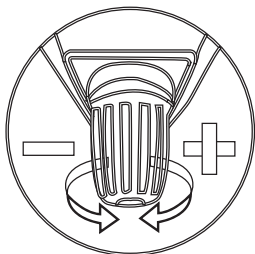

## 7. Kilitleme tekeri

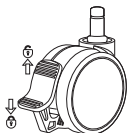

## ประกาศความปลอดภัย



- นั่งตรงกลางเก้าอี้โดยให้หลังพิงพนัก



- อย่านั่งบนขอบเก้าอี้



- อย่ายืนบนเก้าอี้



- อย่าดันพนักพิงหลังเอนลง เมื่อมีคนนั่งอยู่



- วางมือและเท้าของคุณให้ห่างจากกลไกการปรับเอน

## คำเตือน!

1. ควรใช้งานเก้าอี้ในลักษณะปกติและไม่เป็นอันตรายเท่านั้น เราจะไม่รับผิดชอบต่อความเสียหายใด ๆ อันเป็นผลมาจากการประกอบและ/หรือการใช้งานที่ไม่เหมาะสม
2. น้ำหนักสูงสุดที่รับได้คือ 120 กิโลกรัม (264.5 ปอนด์)
3. อย่าประกอบหรือถอดประกอบเก้าอี้ในลักษณะที่ไม่เหมาะสม
4. โปรดวางเก้าอี้ให้พ้นจากแสงแดดโดยตรงเพื่อป้องกันหนัง
5. โปรดมองดูด้านหลังของคุณเมื่อพนักพิงหลังกลับสู่ตำแหน่งเดิมจากตำแหน่งที่ปรับเอน
6. เพื่อหลีกเลี่ยงความเสียหายกับเก้าอี้ อย่าใช้แรงมากเกินไปในการดึงพนักพิงศีรษะ
7. อย่าพยายามเปิดและสัมผัสที่โคม LED เนื่องจากการทำเช่นนั้นจะทำให้การรับประกันเป็นโมฆะ
8. อัตราค่าลงไฟฟ้าของผลิตภัณฑ์นี้คือ 5V/1A อย่าใช้อะแดปเตอร์ไฟฟ้าที่มีเอาต์พุตเกิน 5V/3A

## A สิ่งที่บรรจุอยู่ในกล่องบรรจุภัณฑ์

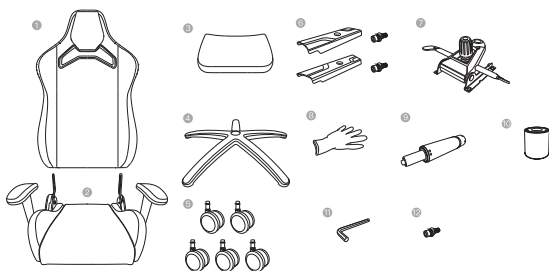

1.	พนักพิงหลัง	5.	ล้อ	9.	กระบอกสเปรย์ไฮดรอลิก
2.	ฐานที่นั่ง	6.	แผ่นปิดด้านข้าง พร้อมสลักเกลียว	10.	ฝาครอบแบบสามก้น
3.	เบาะรองเอา	7.	ชุดควบคุม	11.	กุญแจหกเหลี่ยม
4.	ฐานล้อ	8.	ถุงมือ	12.	สลักเกลียวอะไหล่

**หมายเหตุ:** ภาพประกอบนี้ใช้สำหรับการอ้างอิงเท่านั้นและอาจแตกต่างจากเก้าอี้จริงในลักษณะและคุณสมบัติ



## B การประกอบเก้าอี้

สวมถุงมือก่อนการติดตั้ง

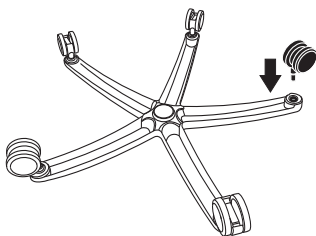

- 1 ใส่และขันล้อเข้าในฐาน ที่ละล้อ

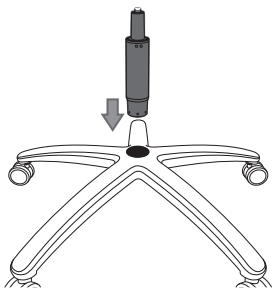

- 2 ใส่กระบอกลูกสูบยกไฮดรอลิกเข้าไปที่รูตรงกลางของฐาน ถอดฝาปิดสีแดงด้านนอกถ้ามี

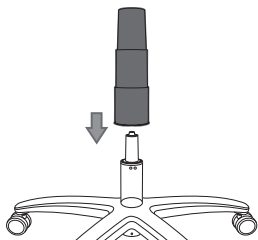

- 3 วางฝาครอบแบบสามก้นที่ด้านบนของกระบอกลูกสูบยกไฮดรอลิก

โดยปกติที่วางแขนจะไม่แยกด้านข้างเว้นแต่จะ  
ติดตั้งฉากเป็นอย่างอื่น

สำหรับรุ่นที่มีที่เท้าแขนประกอบไว้ล่วงหน้า  
โปรดข้ามขั้นตอน

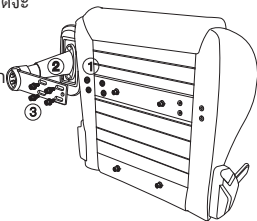

- 4 กอดสลักเกลียวและแหวนรองที่ประกอบไว้ล่วงหน้า (1 & 3).  
วางแหวนรองขนาดใหญ่ 4 ตัว (1) ระหว่างแถบยึดที่วางแขน (2) และฐานที่นั่ง  
จัดที่วางแขนให้เข้าที่ จากนั้นใส่และขันสลักเกลียวทั้ง 4 ตัว (3).  
ให้แน่น ใช้กุญแจหกเหลี่ยมเพื่อขันสลักเกลียวทั้งหมด และทำซ้ำในอีกข้าง

- 5 ใช้กุญแจหกเหลี่ยมเพื่อถอดสลักเกลียว  
และแหวนรองที่ประกอบไว้ล่วงหน้าออกจากที่วางแขน

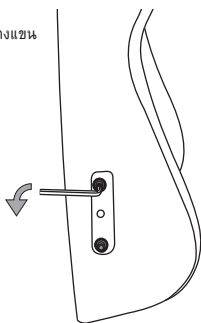

- 6 กอดแผ่นครอบฟิม์ป้องกันออกจากที่เท้าแขนบนฐานที่นั่ง  
จากนั้นปรับตำแหน่งพนักพิงหลังอย่างระมัดระวังระหว่างที่เท้าแขน  
ใส่และยึดสลักเกลียว 4 ตัว (2 ตัวในแต่ละด้าน) ที่คุณถอดออกด้วยมือในขั้นตอนที่ 5  
จากนั้นใช้กุญแจหกเหลี่ยมขันสลักเกลียวทั้งหมด เริ่มคุณด้วยสลักเกลียวสองตัวที่ด้านบน  
ของแต่ละด้านจากนั้นจึงทำการขันสลักเกลียวสองตัวด้านล่าง

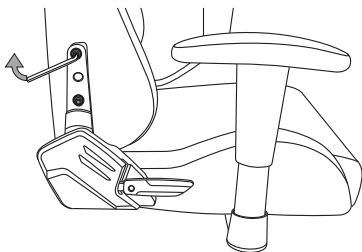

- 7 ดัดตั้งแผ่นปิดด้านข้างและชั้นสลักเกลียว (แผ่นปิดที่มีทำเครื่องหมาย "L" สำหรับด้านซ้ายและ "R" สำหรับด้านขวาตามใน)

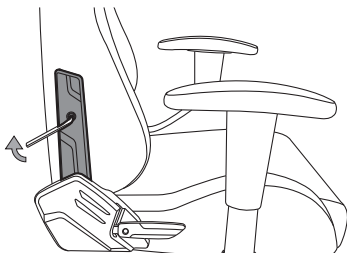

- 8 ดอนนัฟล็อกเกี้ยวอู่คว่ำลง จากน้กอดคอสลักเกลียวที่ติดตั้งไว้ล่วงหน้า 4 ตัวออกจากด้านล่างพร้อมกัับแหวนรอง

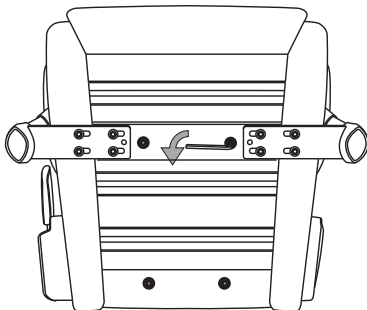

- 9 ทำซ้ำขั้นตอนข้างต้นเพื่อติดตั้งชุดควบคุม จากนั้นใส่ล้อเพื่อยึดกระบอกสูบยกไฮดรอลิกโดยหันหน้าไปทางด้านหลังของที่นั่ง (ตำแหน่งที่ติดตั้งหนักทั้งหลัง)

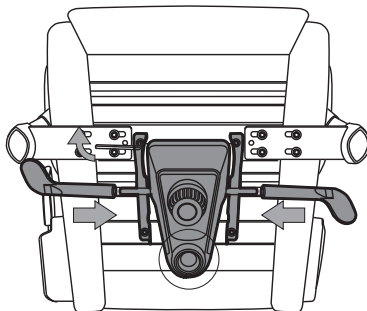

- 10 ใส่ด้านบนของกระบอกลูกสูบยกไฮดรอลิกเข้าไปในรูสำหรับติดตั้งบนชุดความคุม จากนั้น หมุนเกาอีในตำแหน่งตั้งตรง (ใช้แรงงานสองคนในการดำเนินการเพื่อความปลอดภัย)

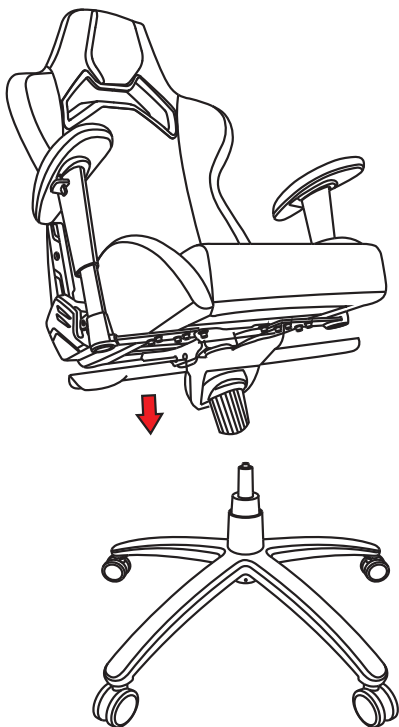

## C การเปิดไฟเก้าอี้

1. ใส่พาวเวอร์แบงก์เข้าไปที่แพ็คเกจด้านหลังเก้าอี้

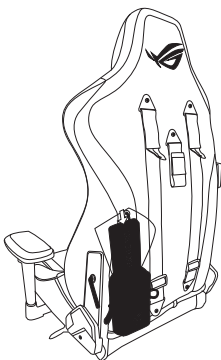

2. เชื่อมต่อตัวเชื่อมต่อ USB Type-A เข้ากับพาวเวอร์แบงก์ของคุณ

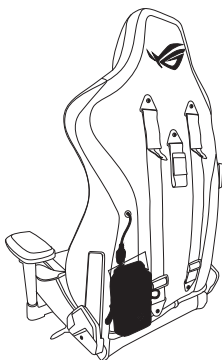

3. ฝักแพดเกิดเข้ากับเก้าอี้ด้วย Velcro  
คุณสามารถเอาออกหรือแยกออกได้อย่างง่ายดาย

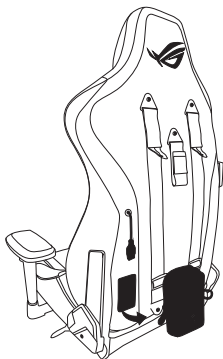

## D คุณสมบัติอื่นๆ

a

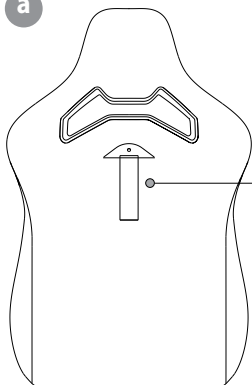

ที่แขนที่ด้านหลังของเก้าอี้สำหรับแขนกระเป๋าสีเสื้อ ผา ถาย และอื่น ๆ

น้ำหนักสูงสุดที่รับได้: 2 กก

โปรดอย่าแขวนสิ่งของที่น้ำหนักเกิน 2 กก

## b การใช้ตัวควบคุม RGB

กำลังไฟ: 5V=1A

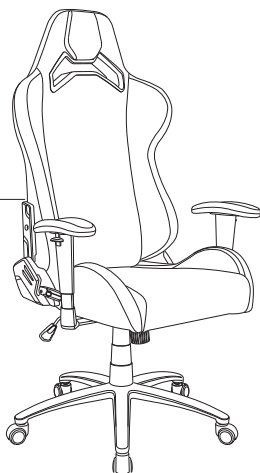
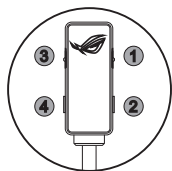

อย่าแกะตัวควบคุมที่ไม่สามารถแกะได้ออก เนื่องจากการทำเช่นนั้นจะทำให้การรับประกันเป็นโมฆะ

1. ระบบไฟ Aura RGB: On (เปิด) / Effect (เอฟเฟกต์) / Off (ปิด)  
กดซ้ำ ๆ เพื่อเปิดหรือปิดไฟ LED ของ Aura RGB หรือหมุนเวียนไปตามเอฟเฟกต์ 7 รายการในปัจจุบัน: (1) สี่จิ้ง (2) กะพริบ (3) วงจรสี (4) คลื่น (5) Yo-Yo เรืองแสง (6) แสงแฟลช (7) แบบคงที่  
กดปุ่มระบบไฟ Aura RGB เป็นเวลา 3 วินาทีเพื่อปิดแสง  
กดเพื่อปลุกอีกครั้งหรือเชื่อมต่อพาวเวอร์แบงค์ใหม่จะคงการตั้งค่าก่อนหน้าไว้  
**หมายเหตุ:** พาวเวอร์แบงค์อาจปรับเอาต์พุตของตนเองโดยอัตโนมัติเมื่อหยุดการทำงานของระบบไฟ ตัดการเชื่อมต่อและเชื่อมต่ออีกครั้งหากไม่สามารถเรียกคืนการทำงานของระบบไฟ Aura RGB หลังจากสลับกลับเป็นเปิด
2. สี Aura RGB  
กดซ้ำ ๆ เพื่อหมุนเวียนไปตามสีที่จัดเต็ม 8 สีต่อไปนี้: (1) สีแดง (2) สีส้ม (3) สีเหลือง (4) สีเขียว (5) สีน้ำเงิน (6) สีคราม (7) สีม่วง (8) สีชมพู  
**หมายเหตุ:** คุณสมบัตินี้มีเฉพาะในเอฟเฟกต์ Aura RGB ต่อไปนี้: (2) กะพริบ (6) แสงแฟลช (7) แบบคงที่
3. ความเร็วของ Aura RGB: Slow (ช้า) / Medium (กลาง) / Fast (เร็ว)  
กดซ้ำ ๆ เพื่อหมุนเวียนไปตามความเร็วของเอฟเฟกต์สี 3 สีต่อไปนี้: (1) Slow (ช้า) (2) Medium (กลาง) (3) Fast (เร็ว)  
**หมายเหตุ:** คุณสมบัตินี้มีเฉพาะในเอฟเฟกต์ Aura RGB ต่อไปนี้: (1) สี่จิ้ง (2) กะพริบ (3) วงจรสี (4) คลื่น (5) Yo-Yo เรืองแสง (6) แสงแฟลช
4. ความสว่างของ Aura RGB: 50% / 75% / 100%  
ความสว่าง 3 ระดับ ความสว่างสามารถเปลี่ยนได้โดยการแตะเพียงครั้งเดียวเพื่อให้เหมาะสมกับสภาพแวดล้อมและความชอบ
5. การรีเซ็ตกลับไปยังโหมดการตั้งค่าเริ่มต้นจากโรงงาน  
กดปุ่ม (2) และปุ่ม (4) พร้อมกันเพื่อรีเซ็ตแก้วของคุณเป็นค่าเริ่มต้นจากโรงงาน



## E ฟังก์ชันที่ปรับได้

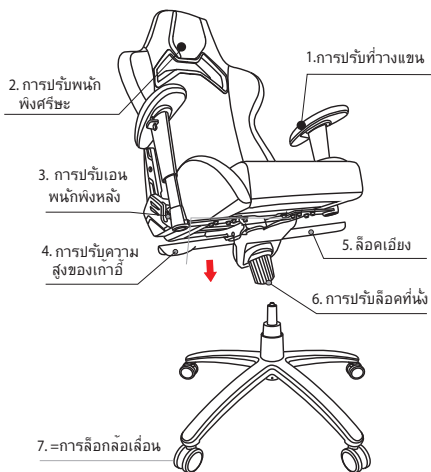

### 1. การปรับที่วางแขน

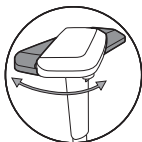

## 2. การปรับพนักพิงศีรษะ

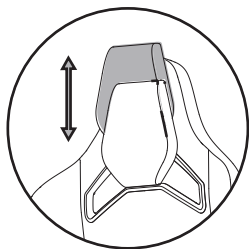

- การปรับความสูง (6 ซม.)
- โปรดอย่ายกพนักพิงศีรษะมากเกินไป

## 3. ดึงคันโยกขึ้นแล้วเอน หลังอย่างช้า ๆ

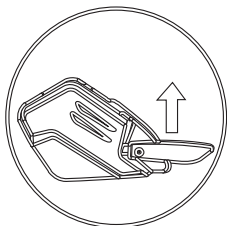

## 4. การปรับความสูงของเก้าอ

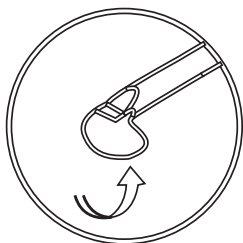

## 5. ล็อค/ ปลดล็อคกลไกการเอียง

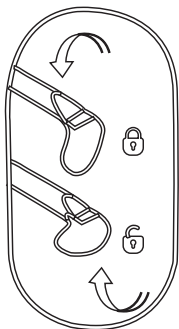

## 6. การปรับลวดที่นั่ง

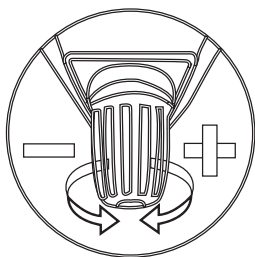

## 7. การล๊อคล้อเลื่อน

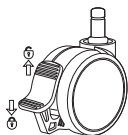

## Federal Communications Commission Statement

This device has been tested and found to comply with the limits for a Class B device, pursuant to Part 15 of the FCC Rules.

These limits are designed to provide reasonable protection against harmful interference in a residential installation. This equipment generates, uses and can radiate radio frequency energy and, if not installed and used in accordance with manufacturer's instructions, may cause harmful interference to radio communications.

However, there is no guarantee that interference will not occur in a particular installation. If this equipment does cause harmful interference to radio or television reception, which can be determined by turning the equipment off and on, the user is encouraged to try to correct the interference by one or more of the following measures:

- Reorient or relocate the receiving antenna.
- Increase the separation between the equipment and receiver.
- Connect the equipment to an outlet on a circuit different from that to which the receiver is connected.
- Consult the dealer or an experienced radio/TV technician for help.

This device complies with Part 15 of the FCC Rules. Operation is subject to the following two conditions:

- This device may not cause harmful interference; and
- This device must accept any interference received including interference that may cause undesired operation.

**CAUTION!** Any changes or modifications not expressly approved by the grantee of this device could void the user's authority to operate the equipment.

## 電波障害自主規制について

この装置は、情報処理装置等電波障害自主規制協議会 (VCCI) の基準に基づく クラス B 情報技術装置です。この装置は、家庭環境で使用することを目的としていますが、この装置がラジオやテレビジョン受信機に近接して使用されると、受信障害を引き起こすことがあります。 取り扱い説明書に従って正しい取り扱いをしてください。



### WARNING

Cancer and Reproductive Harm-  
[www.P65Warnings.ca.gov](http://www.P65Warnings.ca.gov)



电子电气产品有害物质限制使用标识: 图中之数字为产品之环保使用期限。仅指电子电气产品中含有的有害物质不致发生外泄或突变, 从而对环境造成污染或对人身、财产造成严重损害的期限。

## 产品中有害物质的名称及含量

部件名称	有害物质					
	铅 (Pb)	汞 (Hg)	镉 (Cd)	六价铬 (Cr(VI))	多溴联苯 (PBB)	多溴二苯醚 (PBDE)
印刷电路板及其电子组件	○	○	○	○	○	○
外壳	○	○	○	○	○	○
信号连接头及线材	○	○	○	○	○	○
LED 灯	○	○	○	○	○	○

本表格依据 SJ/T 11364 的规定编制。

○：表示该有害物质在该部件所有均质材料中的含量均在 GB/T 26572 规定的限量要求以下。

×：表示该有害物质至少在该部件的某一均质材料中的含量超出 GB/T 26572 规定的限量要求，然该部件仍符合欧盟指令 2011/65/EU 的规范。

备注：此产品所标示之环保使用期限，系指在一般正常使用状况下。

## ASUS Recycling/Takeback Services

ASUS recycling and takeback programs come from our commitment to the highest standards for protecting our environment. We believe in providing solutions for you to be able to responsibly recycle our products, batteries, other components, as well as the packaging materials. Please go to <http://csr.asus.com/english/Takeback.htm> for the detailed recycling information in different regions.



**CAUTION!** DO NOT throw the product in municipal waste. This product has been designed to enable proper reuse of parts and recycling. This symbol of the crossed out wheeled bin indicates that the product (electrical and electronic equipment) should not be placed in municipal waste. Check local regulations for disposal of electronic products.

이 기기는 가정용(B 급)으로 전자파적합등록을 한 기기로서 주로 가정에서 사용하는 것을 목적으로하며, 모든 지역에서 사용할 수 있습니다.

## Українська Спрощена декларація про відповідність нормам ЄС

ASUSTeK Computer Inc. заявляє, що цей пристрій відповідає основним вимогам та іншим відповідним положенням відповідних Директив. Повний текст декларації відповідності стандартам ЄС доступний на: [www.asus.com/support](http://www.asus.com/support).

## Официальное представительство в России

Горячая линия Службы технической поддержки в России:

Бесплатный федеральный номер для звонков по России: 8-800-100-2787

Номер для пользователей в Москве: +7(495)231-1999

Время работы: Пн-Пт, 09:00 - 21:00 (по московскому времени)

Официальные сайты ASUS в России:

[www.asus.ru](http://www.asus.ru)

[www.asus.com/ru/support](http://www.asus.com/ru/support)

## Authorised distributors in Turkey

### PENTA TEKNOLOJI URUNLERI DAGITIM TICARET A.S.

**Address, City:** DUDULLU ORGANIZE SANAYI BOLGESI NATO YOLU 4.CAD. NO:1  
DUDULLU UMRANIYE 34775 ISTANBUL TURKEY

**Distributor Tel:** 0216 645 82 00

**Country:** TURKEY

### Bilkom Bilişim Hizmetleri A.Ş.

**Address:** Mahir İz Cad. No:26 K:2 Altınzade Üsküdar İstanbul - Türkiye

**Distributor Tel:** +90 216 554 9000

**Country:** TURKEY

### C5 Elektronik Sanayi Ve Ticaret A.Ş.

**Address:** Sahrayıcedit Mah. Omca Sok. Golden Plaza No:33 E Blok Kat: 2 Kadıköy/İSTANBUL

**Distributor Tel:** +90 (216) 411 44 00

**Country:** TURKEY

### Manufacturer: ASUSTeK COMPUTER INC.

**Address:** 4F No.150, LI-TE RD., PEITOU, TAIPEI 112, TAIWAN

**Location:** TAIWAN

**Manufacturer Tel:** 886-2-2894-3447

### ASUS COMPUTER GmbH

**Address:** HARKORT STR. 21-23, 40880 RATINGEN, GERMANY

**Tel:** +49-2102-5789555

AEEE Yönetmeliğine Uygundur.



## CE Mark Warning

This is a Class B product, in a domestic environment, this product may cause radio interference, in which case the user may be required to take adequate measures.

### English Simplified EU Declaration of Conformity

ASUSTeK Computer Inc. hereby declares that this device is in compliance with the essential requirements and other relevant provisions of related Directives. Full text of EU declaration of conformity is available at: [www.asus.com/support](http://www.asus.com/support)

### Français Déclaration simplifiée de conformité de l'UE

AsusTek Computer Inc. déclare par la présente que cet appareil est conforme aux critères essentiels et autres clauses pertinentes des directives concernées. La déclaration de conformité de l'UE peut être téléchargée à partir du site Internet suivant : [www.asus.com/support](http://www.asus.com/support).

### Deutsch Vereinfachte EU-Konformitätserklärung

ASUSTeK Computer Inc. erklärt hiermit, dass dieses Gerät mit den wesentlichen Anforderungen und anderen relevanten Bestimmungen der zugehörigen Richtlinien übereinstimmt. Der gesamte Text der EU-Konformitätserklärung ist verfügbar unter: [www.asus.com/support](http://www.asus.com/support).

### Italiano Dichiarazione di conformità UE semplificata

ASUSTeK Computer Inc. con la presente dichiara che questo dispositivo è conforme ai requisiti essenziali e alle altre disposizioni pertinenti con le direttive correlate. Il testo completo della dichiarazione di conformità UE è disponibile all'indirizzo:

[www.asus.com/support](http://www.asus.com/support).

### Русский Упрощенное заявление о соответствии европейской директиве

Компания ASUS заявляет, что это устройство соответствует основным требованиям и другим соответствующим условиям соответствующих директив. Подробную информацию, пожалуйста, смотрите на [www.asus.com/support](http://www.asus.com/support).

### Čeština Zjednodušené prohlášení o shodě EU

Společnost ASUSTeK Computer Inc. tímto prohlašuje, že toto zařízení splňuje základní požadavky a další příslušná ustanovení souvisejících směrnic. Plné znění prohlášení o shodě EU je k dispozici na adrese: [www.asus.com/support](http://www.asus.com/support).

## **Magyar** Egyszerűsített EU megfelelőségi nyilatkozat

Az ASUSTeK Computer Inc. ezennel kijelenti, hogy ez az eszköz megfelel a kapcsolódó Irányelvek lényeges követelményeinek és egyéb vonatkozó rendelkezéseinek. Az EU megfelelőségi nyilatkozat teljes szövege innen letölthető: [www.asus.com/support](http://www.asus.com/support).

## **Polski** Uproszczona deklaracja zgodności UE

Firma ASUSTeK Computer Inc. niniejszym oświadcza, że urządzenie to jest zgodne z zasadniczymi wymogami i innymi właściwymi postanowieniami powiązanych dyrektyw. Pełny tekst deklaracji zgodności UE jest dostępny pod adresem: [www.asus.com/support](http://www.asus.com/support).

## **Português** Declaração de Conformidade Simplificada da UE

A ASUSTeK Computer Inc. declara que este dispositivo está em conformidade com os requisitos essenciais e outras disposições relevantes das Diretivas relacionadas. Texto integral da declaração da UE disponível em: [www.asus.com/support](http://www.asus.com/support).

## **Română** Declarație de conformitate UE, versiune simplificată

ASUSTeK Computer Inc. declară că acest dispozitiv se conformează cerințelor esențiale și altor prevederi relevante ale directivelor conexe. Textul complet al declarației de conformitate a Uniunii Europene se găsește la: [www.asus.com/support](http://www.asus.com/support).

## **Slovensky** Zjednodušené vyhlásenie o zhode platné pre EÚ

Spoločnosť ASUSTeK Computer Inc. týmto vyhlasuje, že toto zariadenie vyhovuje základným požiadavkám a ostatným príslušným ustanoveniam príslušných smerníc. Celý text vyhlásenia o zhode pre štáty EÚ je dostupný na adrese: [www.asus.com/support](http://www.asus.com/support)

## **Slovenščina** Poenostavljena izjava EU o skladnosti

ASUSTeK Computer Inc. izjavlja, da je ta naprava skladna z bistvenimi zahtevami in drugimi ustreznimi določbami povezanih direktiv. Celotno besedilo EU-izjave o skladnosti je na voljo na spletnem mestu: [www.asus.com/support](http://www.asus.com/support).

## **Español** Declaración de conformidad simplificada para la UE

Por la presente, ASUSTeK Computer Inc. declara que este dispositivo cumple los requisitos básicos y otras disposiciones pertinentes de las directivas relacionadas. El texto completo de la declaración de la UE de conformidad está disponible en: [www.asus.com/support](http://www.asus.com/support).

## **Türkçe** Basitleştirilmiş AB Uyumluluk Bildirimi

AsusTek Computer Inc., bu aygıtın temel gereksinimlerle ve ilişkili Yönergelerin diğer ilgili koşullarıyla uyumlu olduğunu beyan eder. AB uygunluk bildiriminin tam metni şu adreste bulunabilir: [www.asus.com/support](http://www.asus.com/support).

## **Copyright Information**

You acknowledge that all rights of this Manual remain with ASUS. Any and all rights, including without limitation, in the Manual or website, are and shall remain the exclusive property of ASUS and/or its licensors. Nothing in this Manual intends to transfer any such rights, or to vest any such rights to you.

ASUS PROVIDES THIS MANUAL "AS IS" WITHOUT WARRANTY OF ANY KIND. SPECIFICATIONS AND INFORMATION CONTAINED IN THIS MANUAL ARE FURNISHED FOR INFORMATIONAL USE ONLY, AND ARE SUBJECT TO CHANGE AT ANY TIME WITHOUT NOTICE, AND SHOULD NOT BE CONSTRUED AS A COMMITMENT BY ASUS.

## **Limitation of Liability**

Circumstances may arise where because of a default on ASUS' part or other liability, you are entitled to recover damages from ASUS. In each such instance, regardless of the basis on which you are entitled to claim damages from ASUS, ASUS is liable for no more than damages for bodily injury (including death) and damage to real property and tangible personal property; or any other actual and direct damages resulted from omission or failure of performing legal duties under this Warranty Statement, up to the listed contract price of each product.

ASUS will only be responsible for or indemnify you for loss, damages or claims based in contract, tort or infringement under this Warranty Statement.

This limit also applies to ASUS' suppliers and its reseller. It is the maximum for which ASUS, its suppliers, and your reseller are collectively responsible.

UNDER NO CIRCUMSTANCES IS ASUS LIABLE FOR ANY OF THE FOLLOWING: (1) THIRD-PARTY CLAIMS AGAINST YOU FOR DAMAGES; (2) LOSS OF, OR DAMAGE TO, YOUR RECORDS OR DATA; OR (3) SPECIAL, INCIDENTAL, OR INDIRECT DAMAGES OR FOR ANY ECONOMIC CONSEQUENTIAL DAMAGES (INCLUDING LOST PROFITS OR SAVINGS), EVEN IF ASUS, ITS SUPPLIERS OR YOUR RESELLER IS INFORMED OF THEIR POSSIBILITY.

## **Service and Support**

For multi-language manuals, please refer to ASUS web site: <http://www.asus.com/support/>



REPUBLIC OF  
GAMERS