

**BMW
MOTORRAD**



Booklet available in English on
Livret disponible en français sur
Folleto disponible en español en







Shell
MOTUL
MAGNERA
PAGON
GILLES

BMW Motorrad

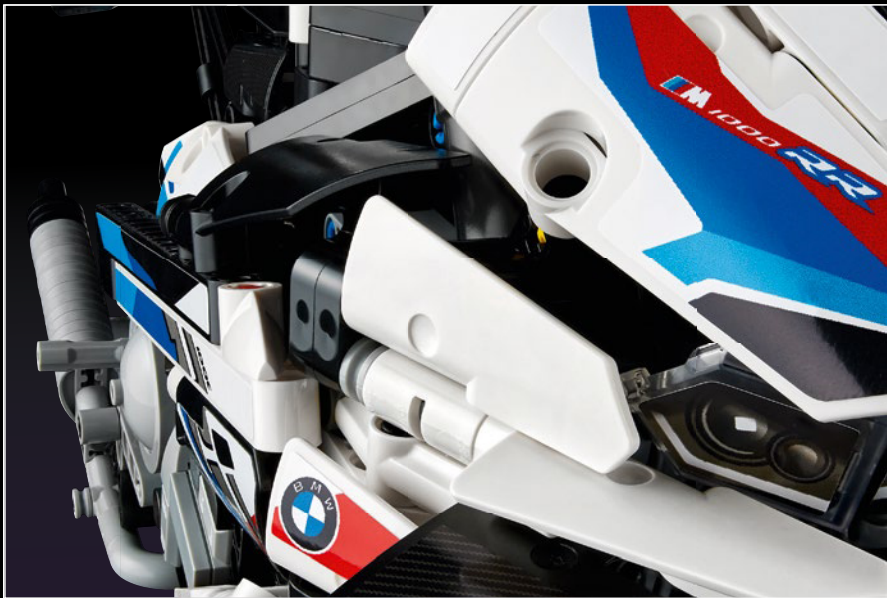
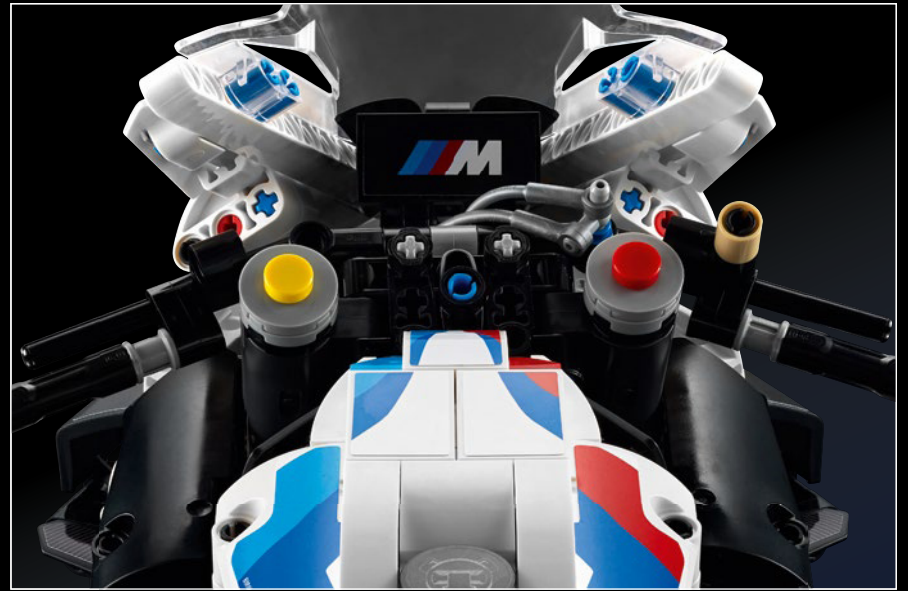

BMW M 1000 RR

When BMW Motorrad's in-house performance experts announced the first-ever M-developed motorcycle, the BMW M RR, everyone knew that the result was going to be something special. In the same way, the LEGO® Technic™ team realized it would take something never seen before to pay true tribute to the M RR. The result is both a motorcycle and a Technic model that are state-of-the-art within their respective fields.

Lorsque les experts en performance de BMW Motorrad ont annoncé la toute première moto développée par Motoradd, la BMW M RR, il était évident que le résultat serait vraiment spécial. Ainsi, l'équipe LEGO® Technic™ a réalisé qu'il faudrait quelque chose d'unique en son genre pour rendre hommage à la M RR. Le résultat est une moto et un modèle Technic qui sont à la fine pointe de la technologie dans leurs domaines respectifs.

Cuando los expertos en desempeño de BMW Motorrad anunciaron la primera moto de la serie M, la BMW M RR, todo el mundo supo que el resultado sería algo especial. De igual manera, el equipo de LEGO® Technic™ se dio cuenta de que haría falta algo nunca antes visto para rendir un verdadero homenaje a la M RR. El resultado es una motocicleta y un modelo Technic a la vanguardia en sus respectivos campos.



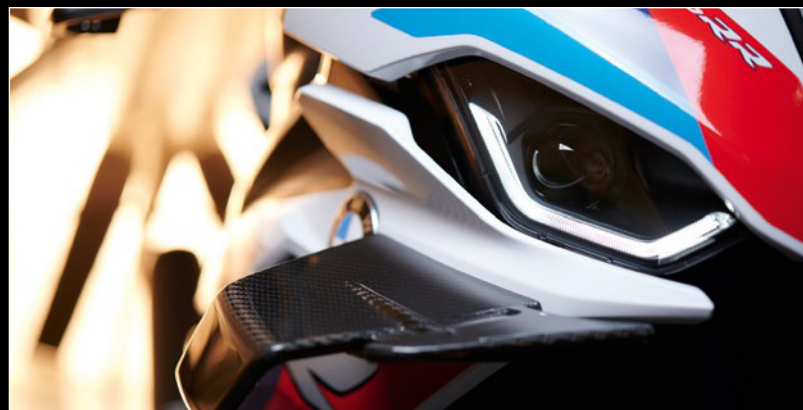

THE PINNACLE OF PERFORMANCE **LE SUMMUM DE LA PERFORMANCE** **LA CÚSPIDE DEL DESEMPEÑO**

The quest for enhanced performance on both racetrack and road is what defines this M version of a high-performance motorcycle. With the original RR superbike as the perfect foundation, the BMW Motorrad team set about coaxing more power out of the water-cooled 999-cc inline four-cylinder engine, while also introducing design upgrades like carbon fiber wheels and a titanium exhaust system to reduce overall weight.

La quête de performance accrue sur piste comme sur route est ce qui définit cette version M d'une moto haute performance. Avec la super moto RR originale comme base parfaite, l'équipe de BMW Motorrad a entrepris de tirer plus de puissance du moteur quatre cylindres en ligne refroidi par eau d'une cylindrée de 999 cm³, tout en ajoutant des améliorations de conception comme des roues en fibre de carbone et un système d'échappement en titane pour réduire le poids total.

La búsqueda del máximo desempeño tanto en la pista de carreras como en la carretera constituye la auténtica esencia de esta versión M de una motocicleta de altas prestaciones. Con la supermoto RR original como base perfecta, el equipo de BMW Motorrad se propuso sacar más potencia del motor de cuatro cilindros en línea de 999 cc refrigerado por agua, introduciendo al mismo tiempo mejoras de diseño (como ruedas de fibra de carbono y un sistema de escape de titanio para reducir el peso total).





A MATTER OF SCALE **UN DÉFI DE TAILLE** **UNA CUESTIÓN DE ESCALA**

The first challenge the LEGO® Technic™ designers faced was to set the scale of the model. Too small and it would be difficult to replicate the many features and functions of the real M RR. Too big and it would challenge the Technic building system. With a 1:5 scale, it became the largest Technic motorcycle model ever created. The Technic team worked closely with the designers and engineers at BMW Motorrad to ensure the LEGO Technic version was as close to the real M RR as possible.

Le premier défi que les concepteurs LEGO® Technic™ ont rencontré a été de définir l'échelle du modèle. Trop petite, les nombreuses caractéristiques et fonctions de la vraie M RR seraient difficiles à reproduire. Trop grande, le système de construction Technic serait mis à l'épreuve. Avec une échelle de 1:5, c'est le plus grand modèle de moto Technic jamais créé. L'équipe de conception de LEGO Technic a travaillé en étroite collaboration avec les concepteurs et les ingénieurs de BMW Motorrad pour assurer que la version LEGO Technic de la M RR imite le plus fidèlement possible la vraie moto.

El primer desafío que enfrentaron los diseñadores de LEGO® Technic™ fue establecer la escala del modelo. De ser demasiado pequeña, reproducir las numerosas características y funciones de la verdadera M RR resultaría muy complicado. De ser demasiado grande, el sistema de construcción Technic se vería en problemas. Con una escala 1:5, este modelo de motocicleta Technic se convirtió en el más grande que se haya creado. El equipo de Technic trabajó hombro a hombro con los diseñadores e ingenieros de BMW Motorrad para asegurarse de que la versión LEGO Technic fuera lo más parecida posible a la M RR de verdad.

SAMUEL TACCHI
Designer/ Concepteur/
Diseñador
LEGO® Technic™





“

IT TOOK ME BACK TO WHEN I WAS DESIGNING MOTORCYCLES.”
« CELA M'A RAMENÉ À L'ÉPOQUE OÙ JE CONCEVAIS DES MOTOS. »
“ME HIZO RECORDAR CUANDO DISEÑABA MOTOS”.

Samuel Tacchi



With a background in motorcycle design and a huge passion for riding them as well, LEGO® Technic™ designer Samuel Tacchi was the natural choice to lead this project.

Vu son expérience dans la conception de motos et son énorme passion pour leur conduite, le concepteur LEGO® Technic™ Samuel Tacchi était tout désigné pour diriger ce projet.

Por su experiencia en el diseño de motocicletas y enorme pasión por conducir las, el diseñador de LEGO® Technic™ Samuel Tacchi era la mejor opción para dirigir el proyecto.

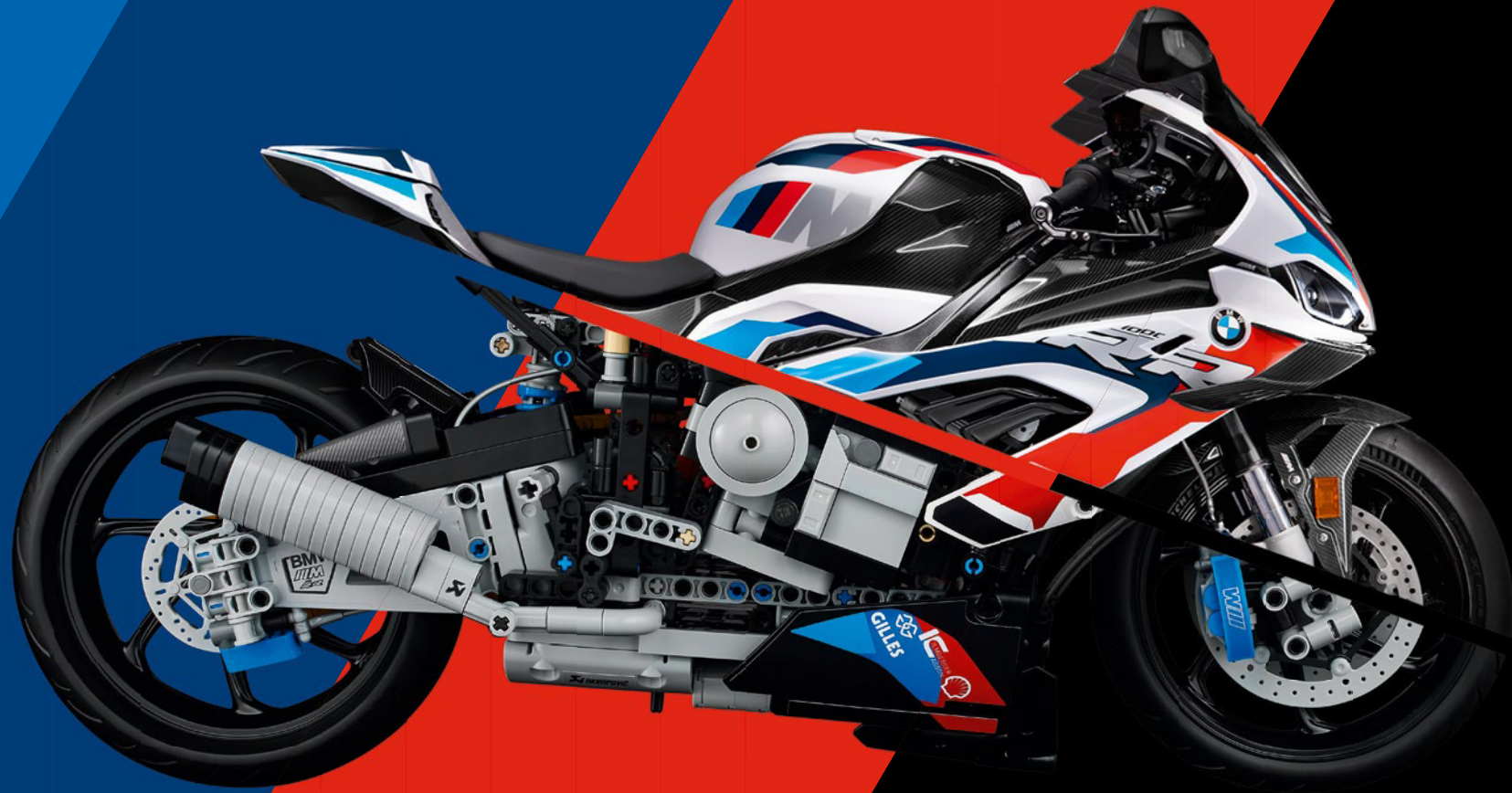

**PUSHING THE TECHNIC™ BUILDING SYSTEM
REPOUSSER LES LIMITES DU SYSTÈME DE
CONSTRUCTION TECHNIC™
UN DESAFÍO PARA EL SISTEMA DE CONSTRUCCIÓN TECHNIC™**

The Technic™ version of the M RR needed the design of eight new pieces and Senior Designer Daniel Sri Sudarsono oversaw this process. It started with the new front and rear suspension setup needed to support the 3 lbs. (1.4 kg) weight of the model. New rims, disc brakes and a transparent windshield quickly followed, all of which had to be tried and tested before being approved for use in the final model.

La version Technic™ de la M RR a nécessité la conception de huit nouvelles pièces. Le concepteur principal Daniel Sri Sudarsono a supervisé ce processus. Il a d'abord fallu reconfigurer la suspension avant et arrière pour supporter le poids de 1,4 kg du modèle. Ensuite, de nouvelles jantes, des freins à disque et un pare-brise transparent ont été ajoutés, puis essayés et testés avant d'être approuvés pour l'utilisation dans le modèle final.

La versión Technic™ de la M RR requirió el diseño de ocho nuevas piezas, un proceso que fue supervisado por el diseñador sénior Daniel Sri Sudarsono. Comenzó con la estructura para la nueva suspensión delantera y trasera, necesaria para soportar los 1,4 kg de peso del modelo. Le siguieron rápidamente nuevos rines, frenos de disco y un parabrisas transparente, todo lo cual tuvo que superar numerosas pruebas antes de recibir la aprobación necesaria para formar parte del modelo final.



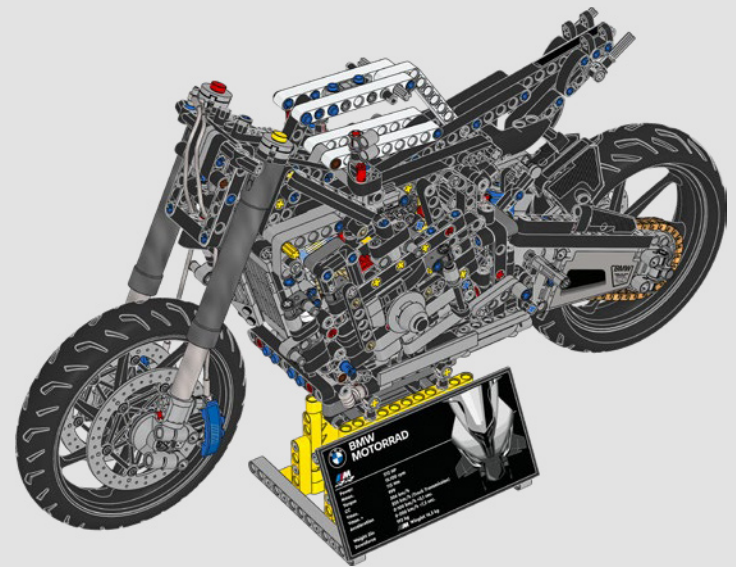
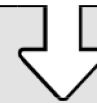
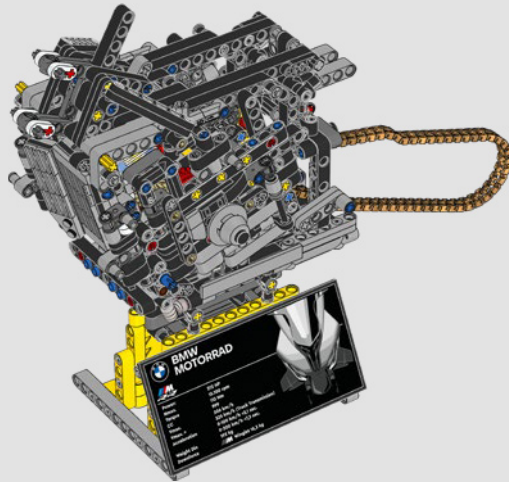
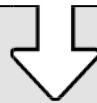
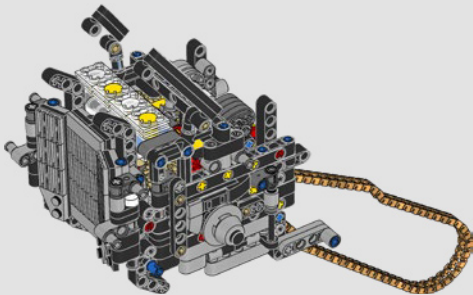
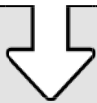

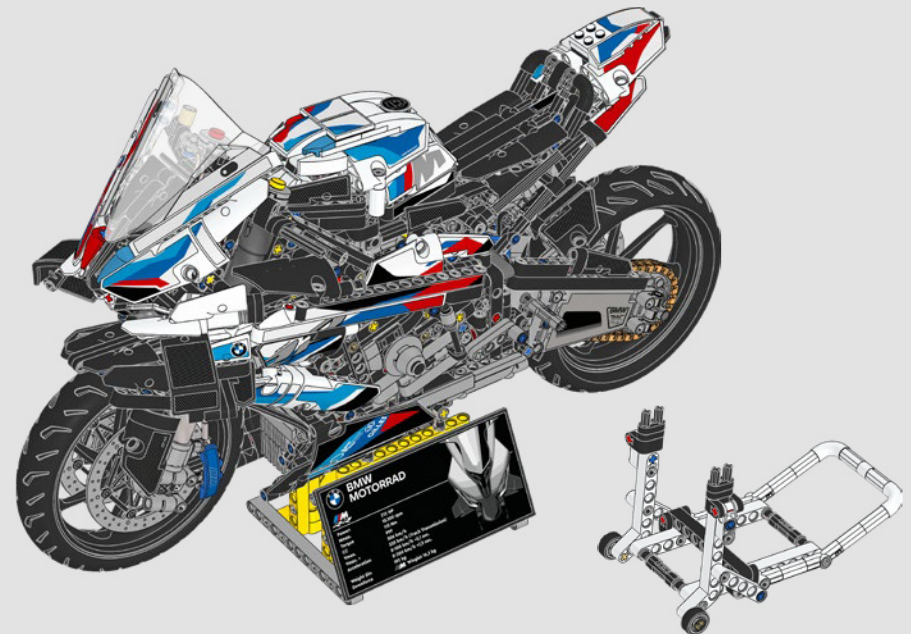
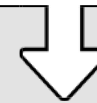
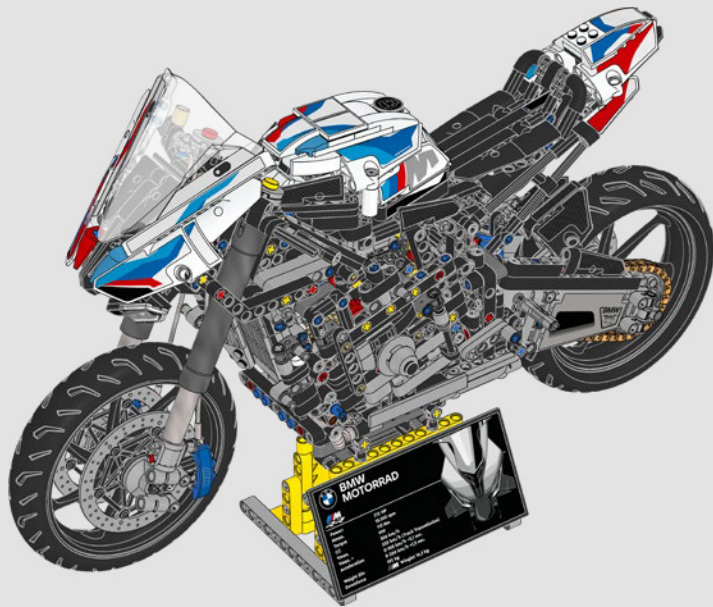
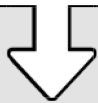

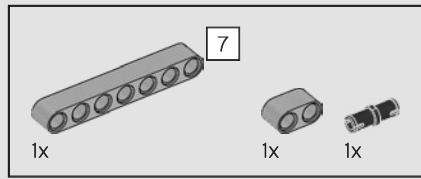
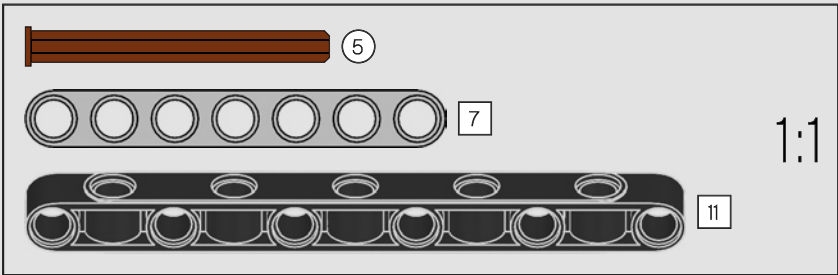
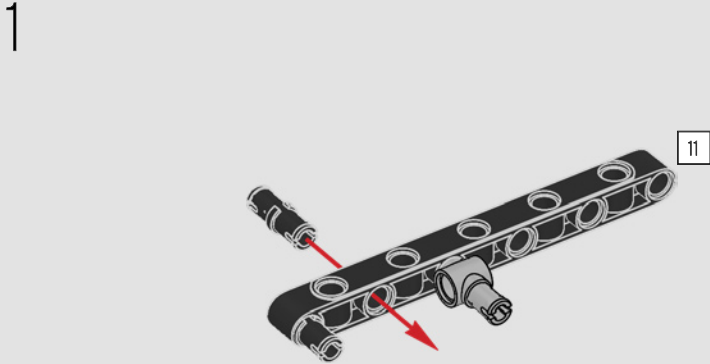
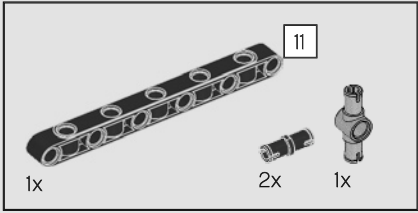
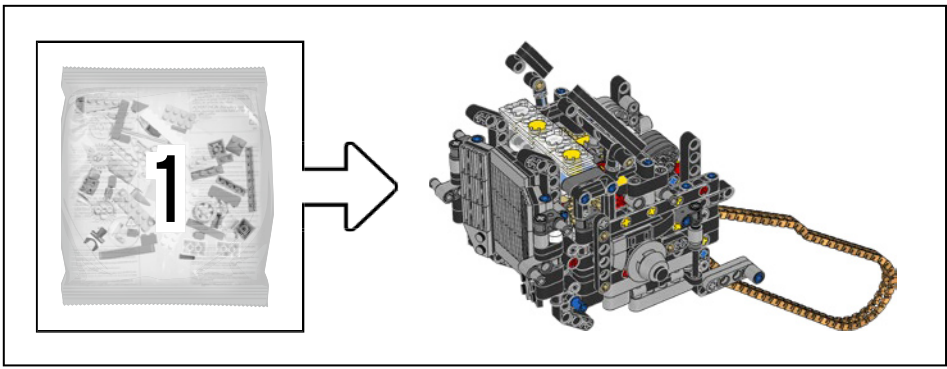

2

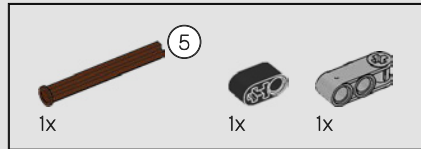
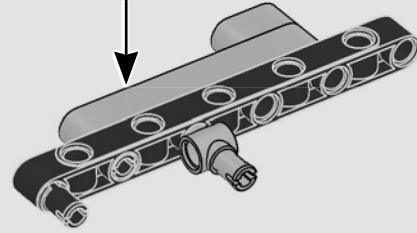
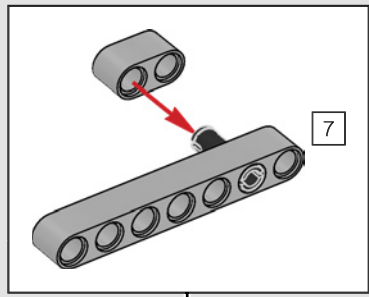

3

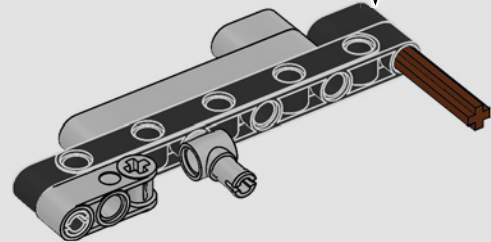
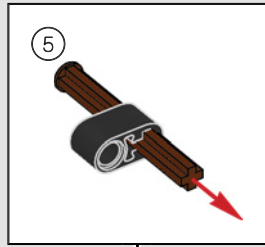



4

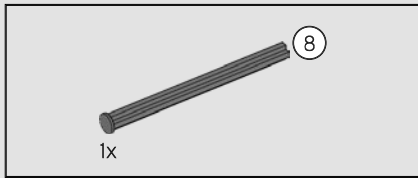
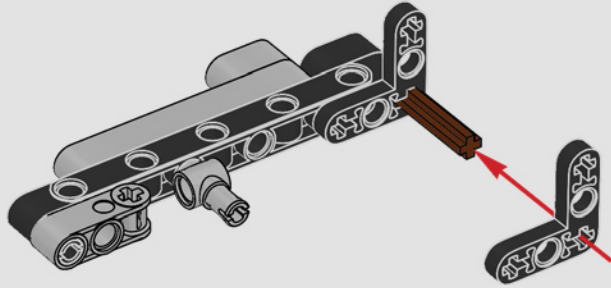

5

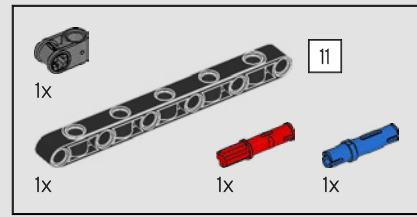
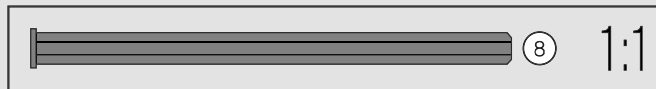
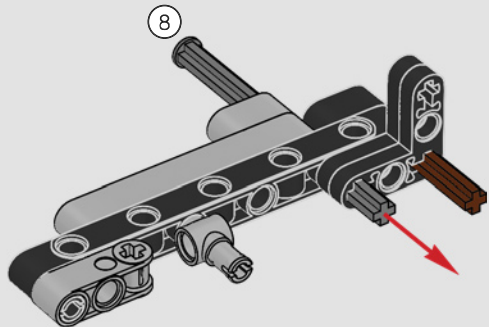

6

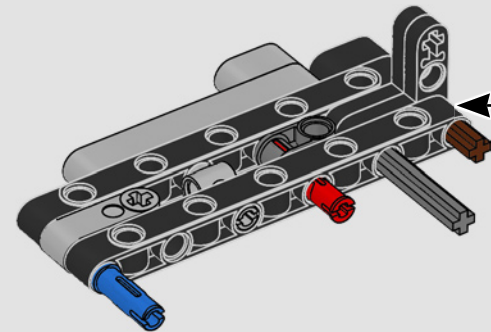
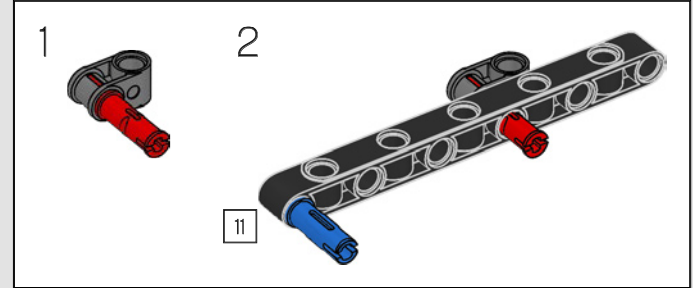

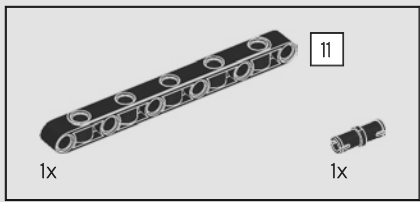

7

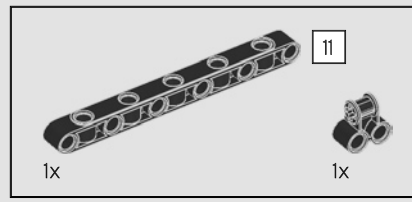
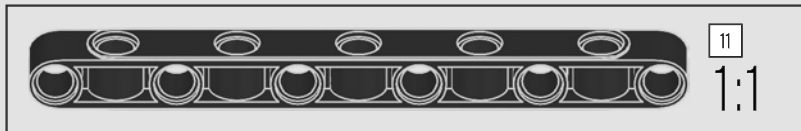
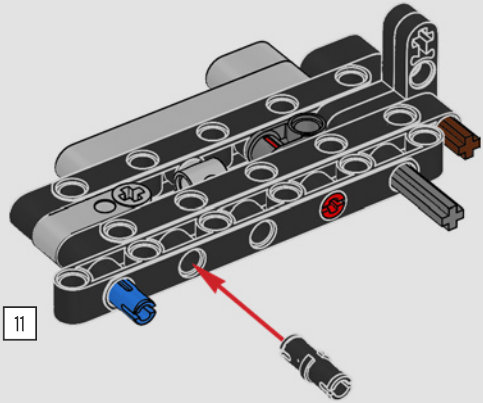

8

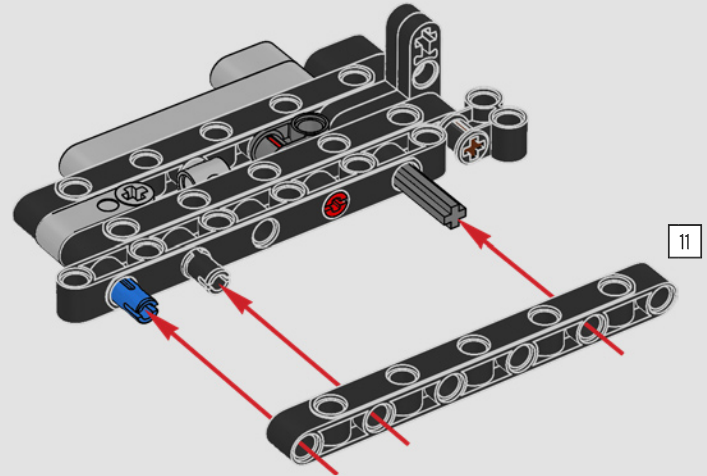

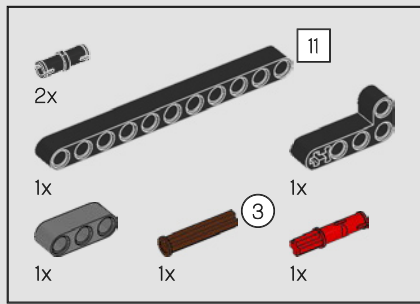

9

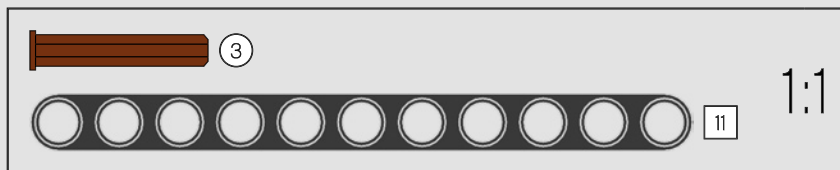
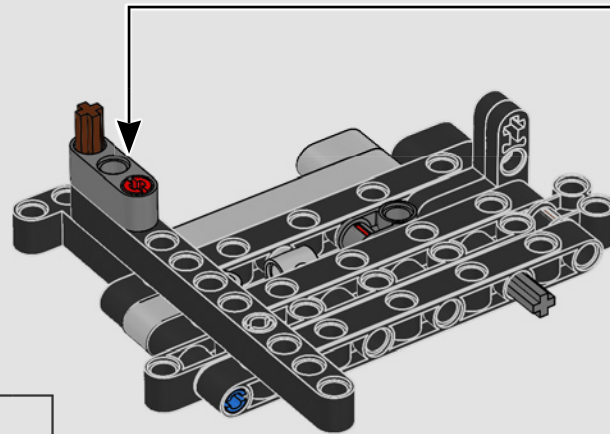
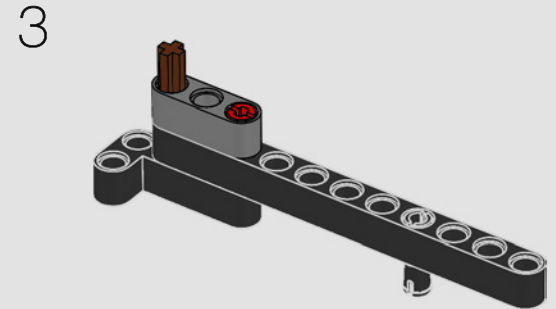
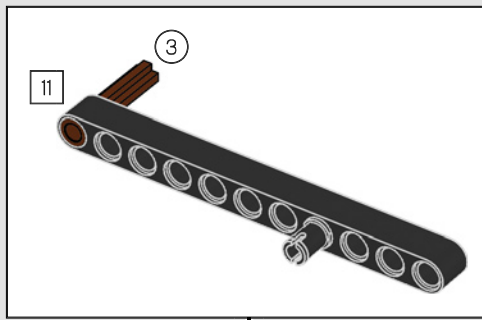
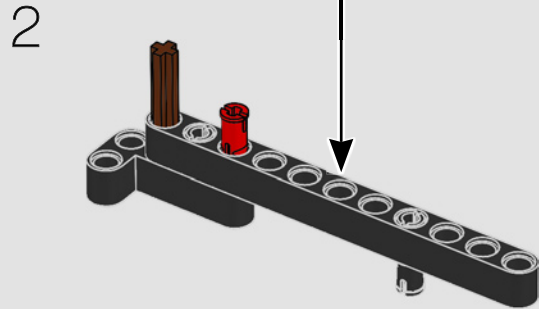
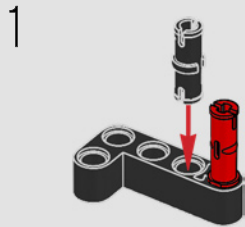

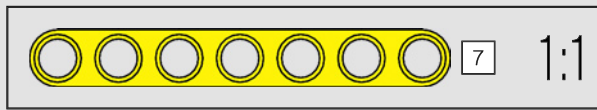
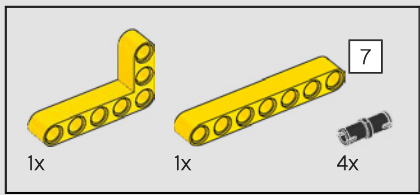

10

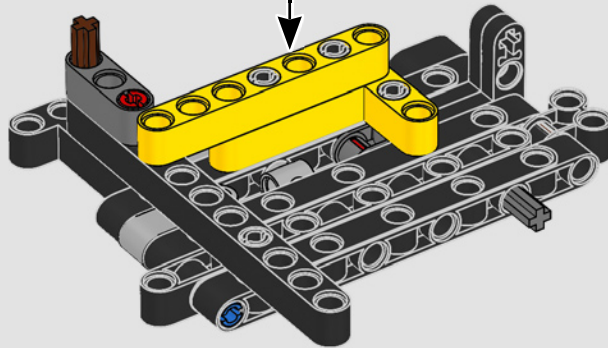
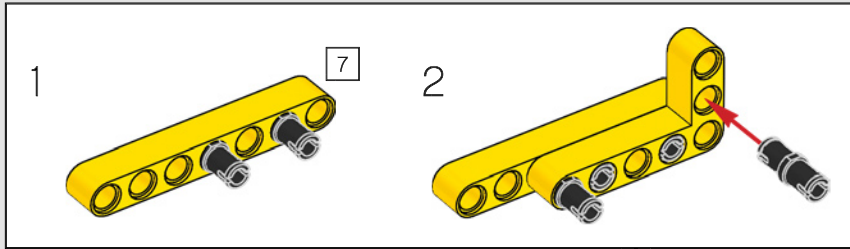

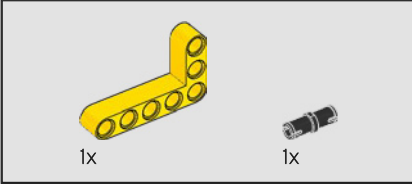
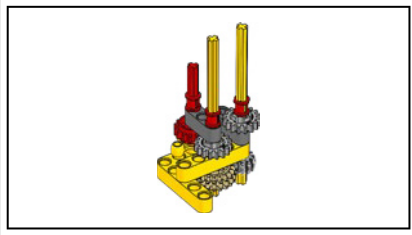

11

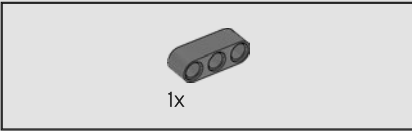
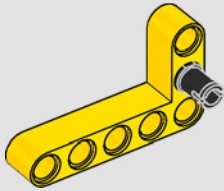

12

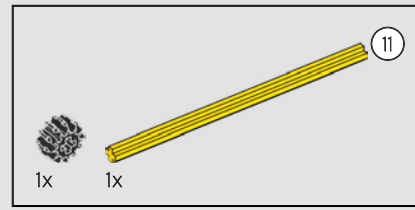
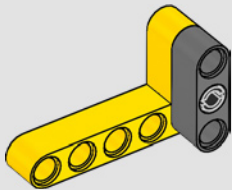

13

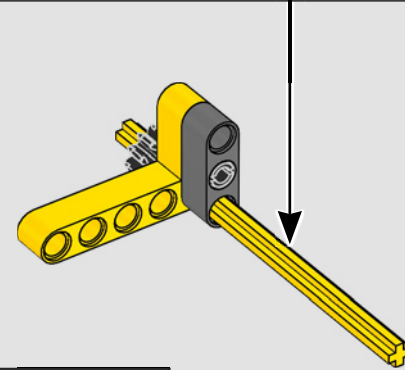
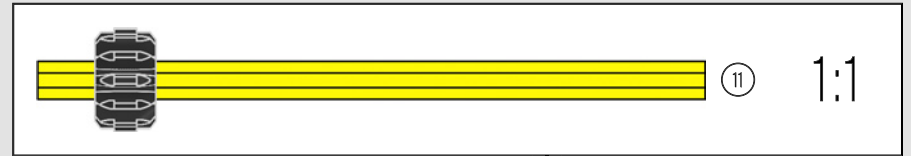

14

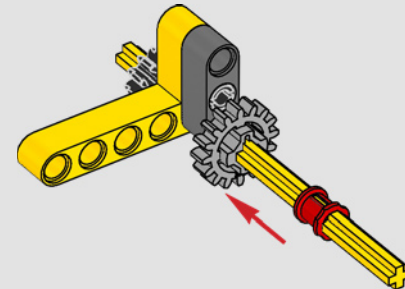

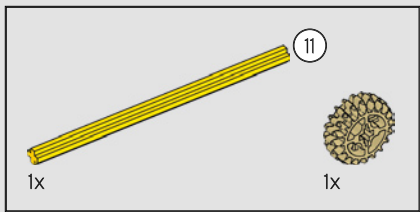

15

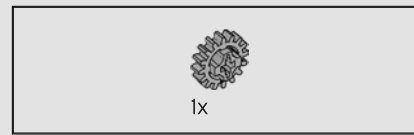
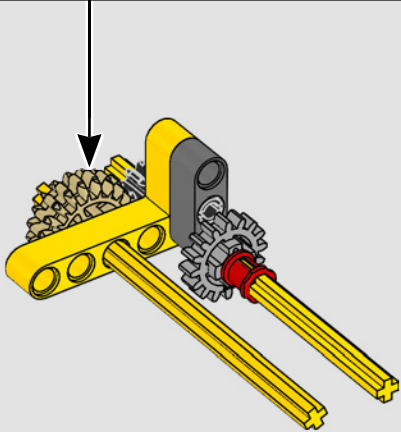
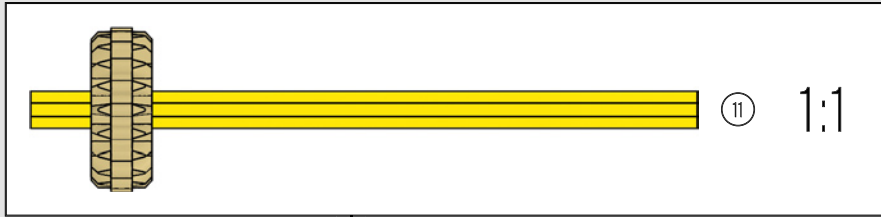

16

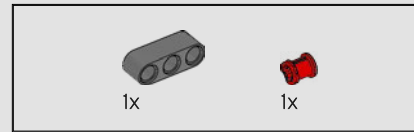
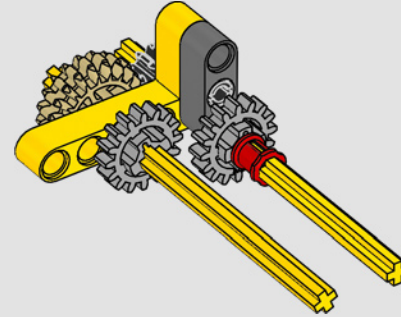

17

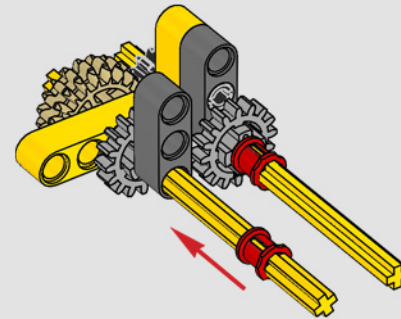

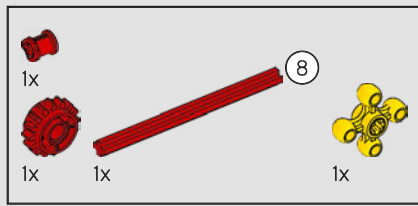

18

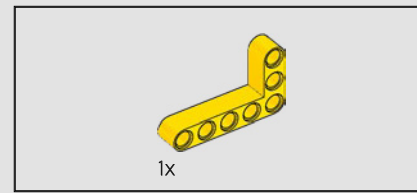
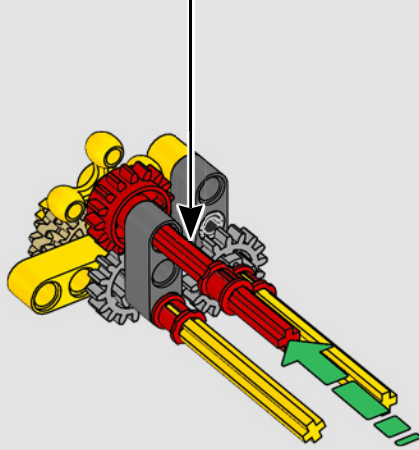
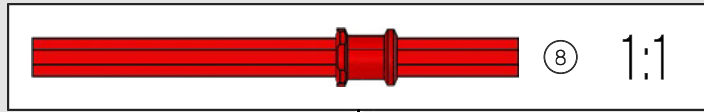

19

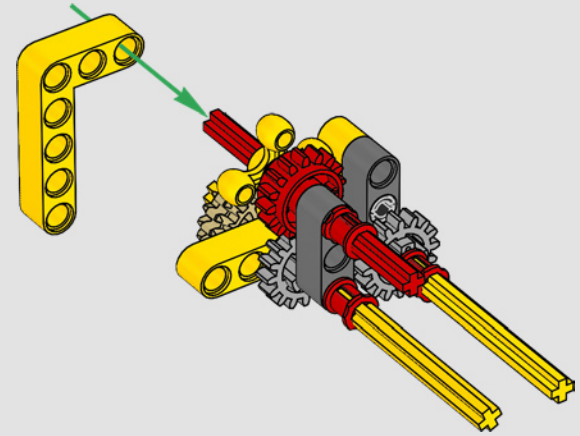

20

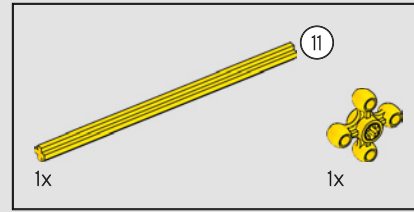
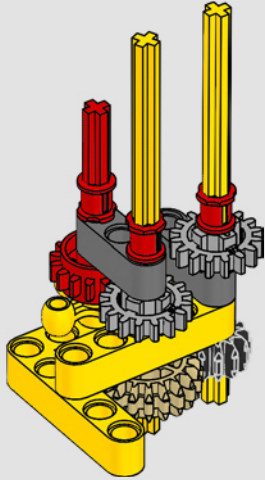

22

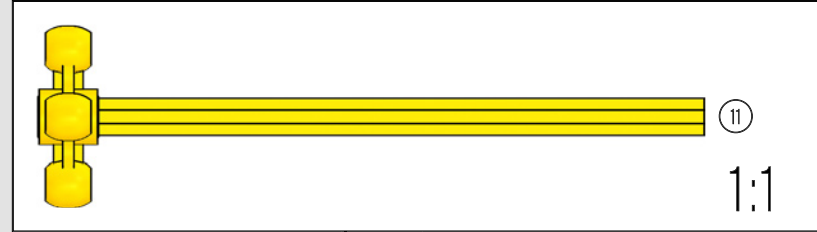

21

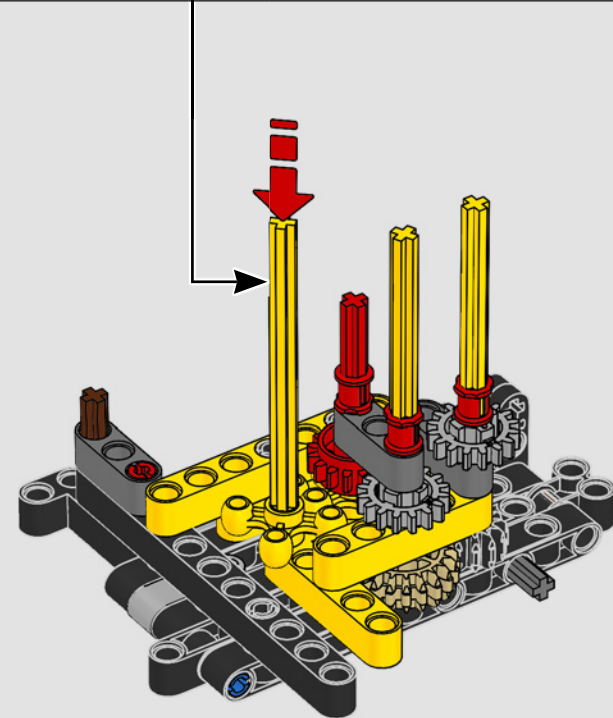
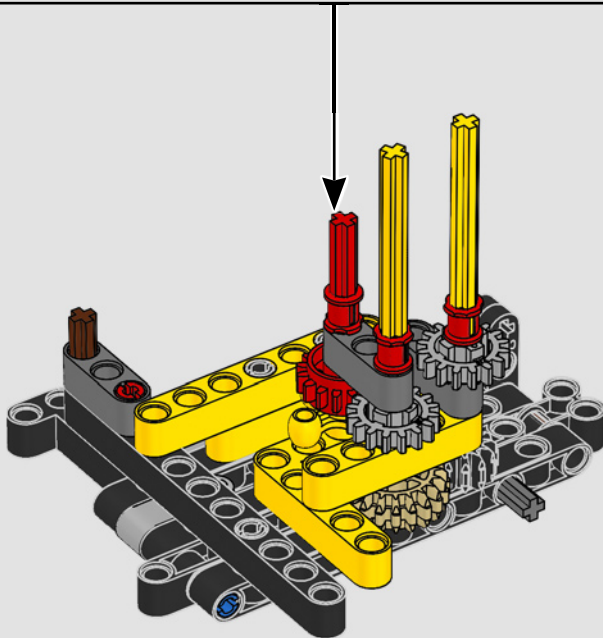

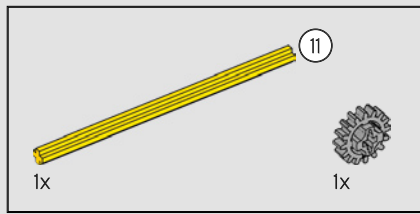

23

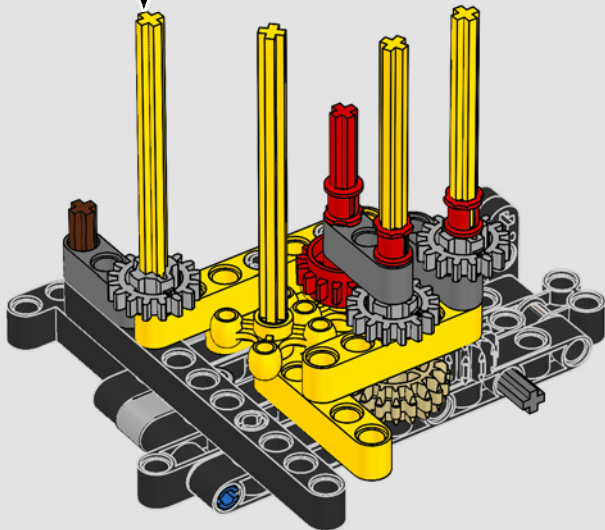
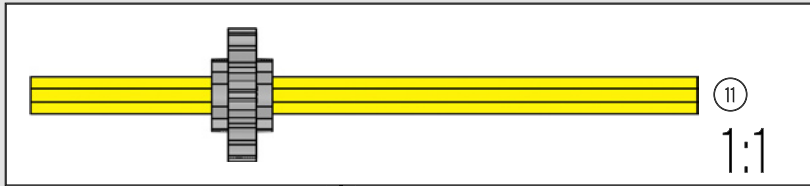

24

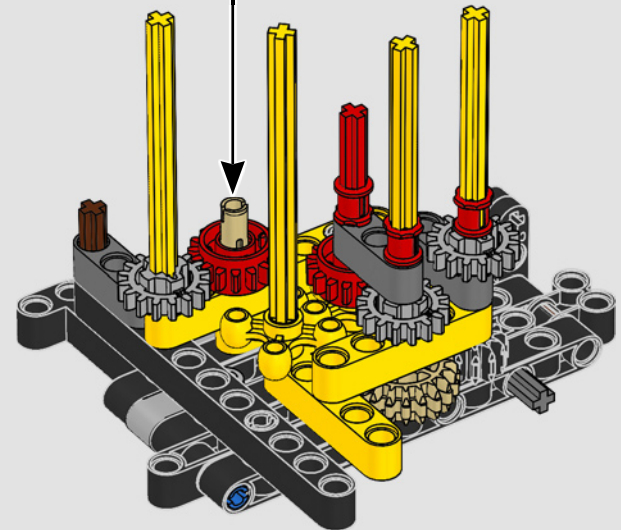
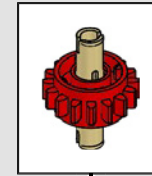

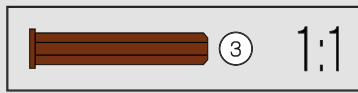
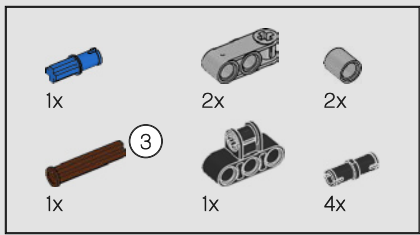

25

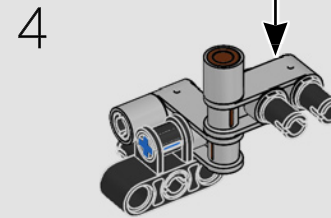
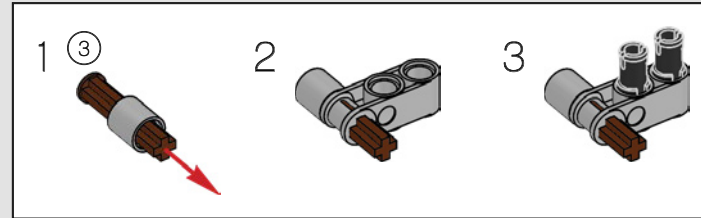
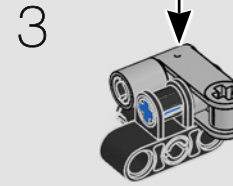
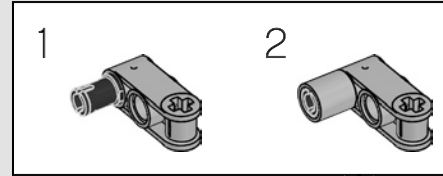
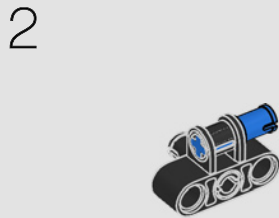
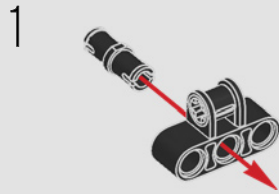

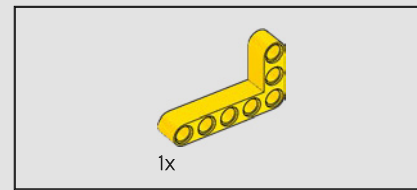
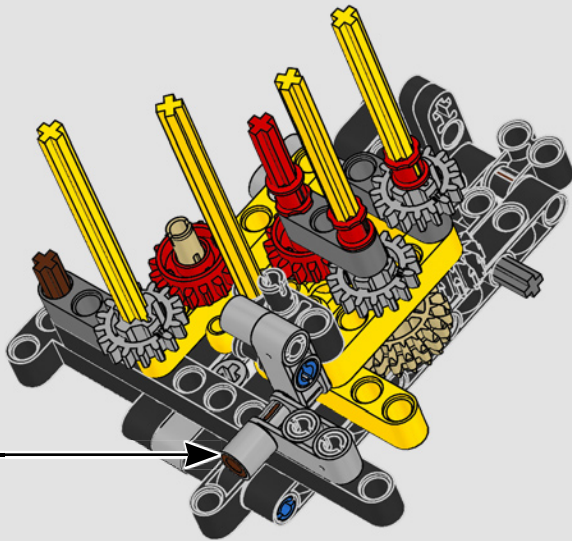

26

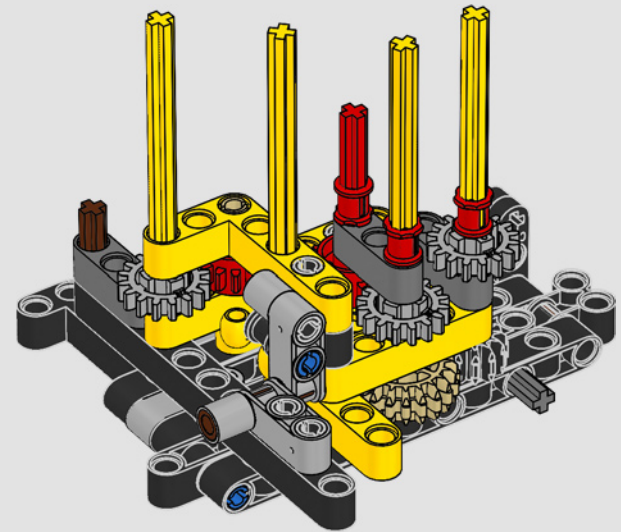

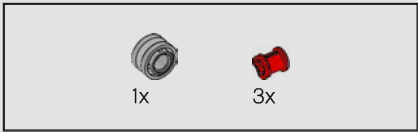

27

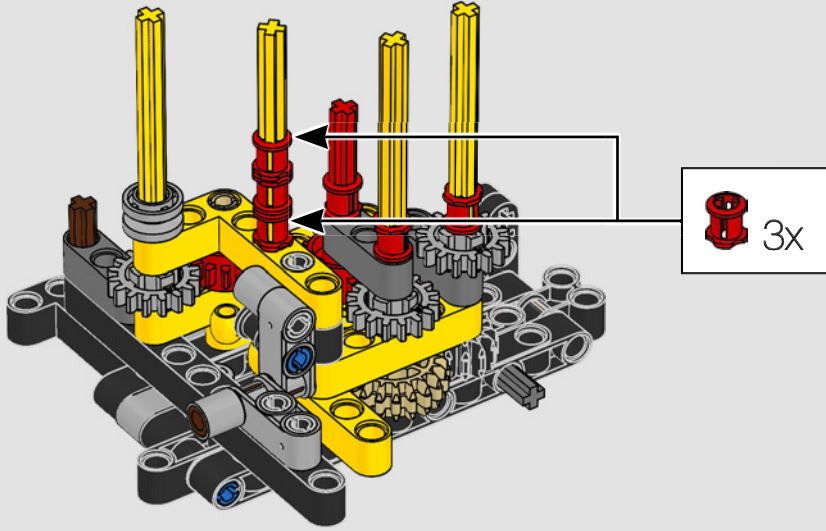

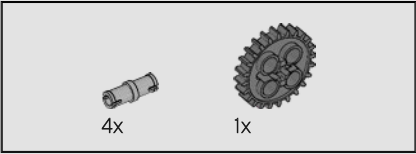
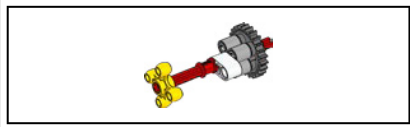

28

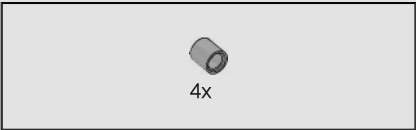
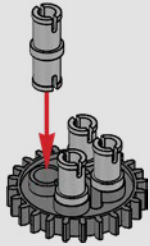

29

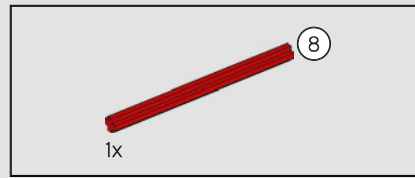
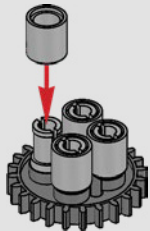

30

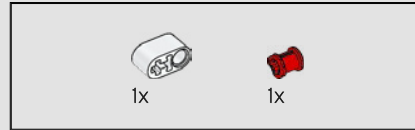
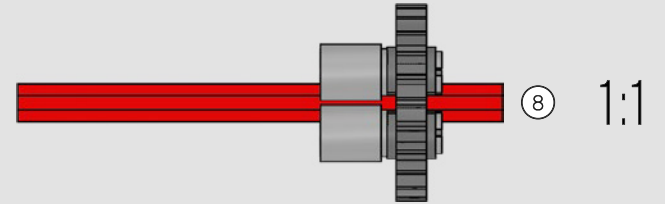

31

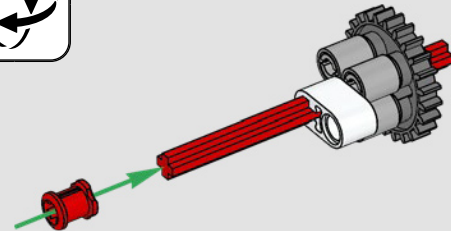
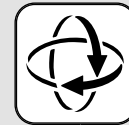



1x

32

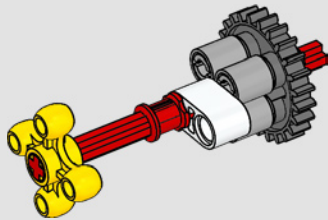

33

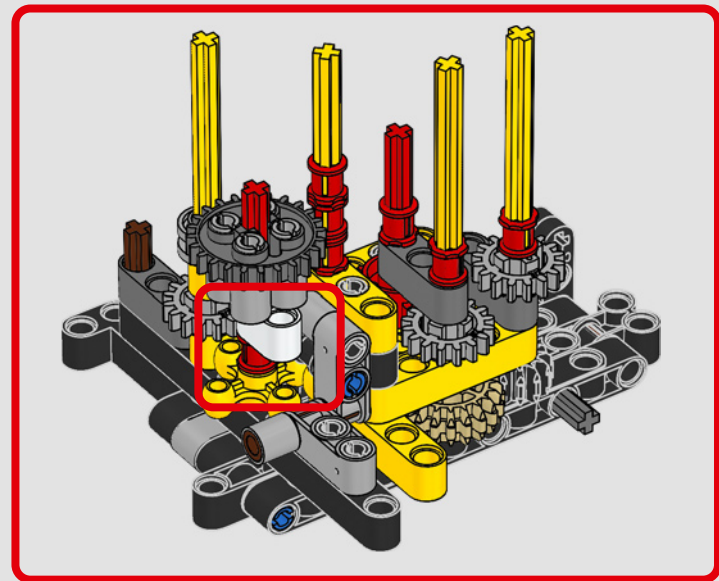
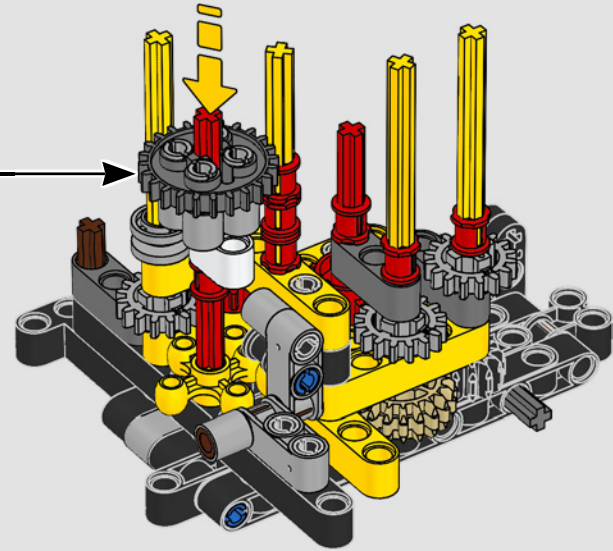

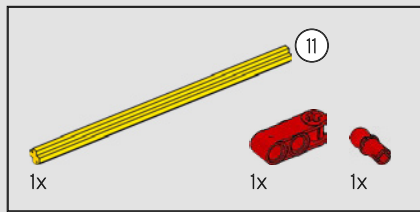

34

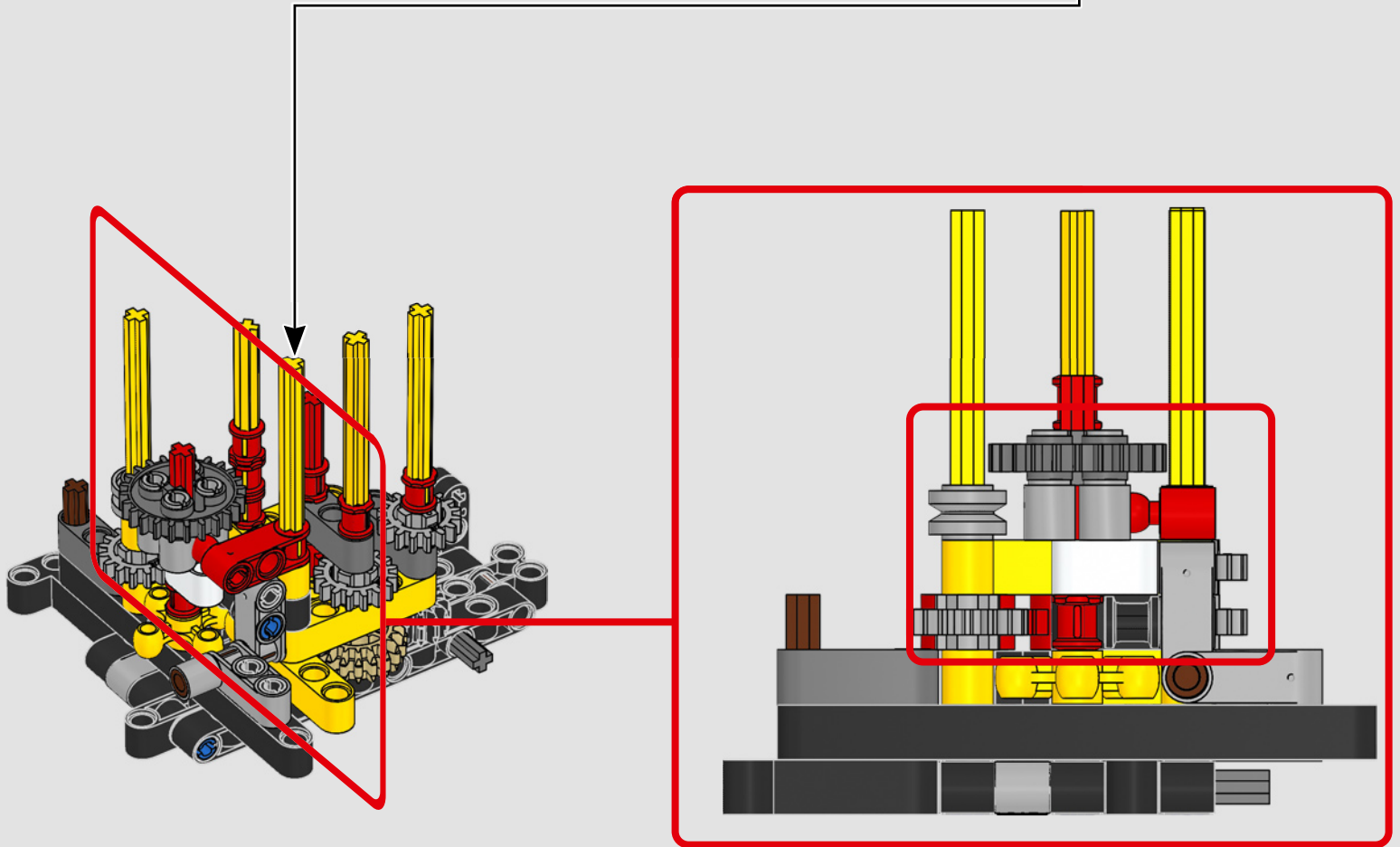
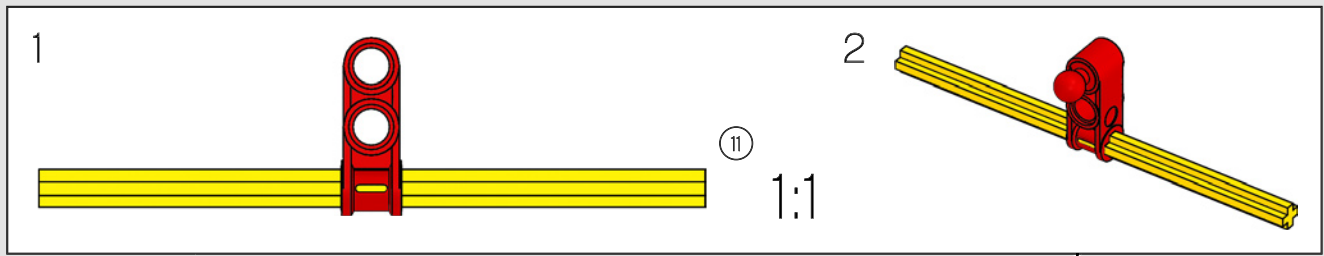

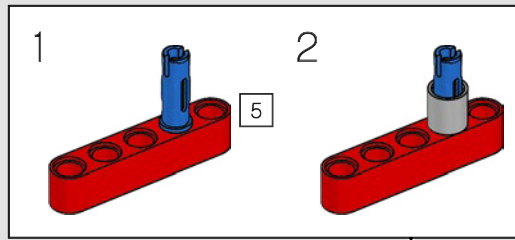
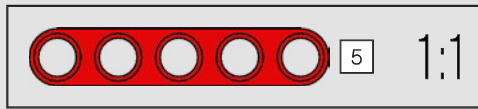
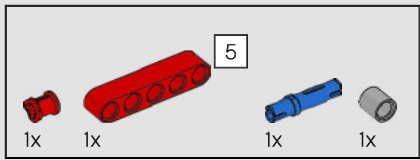

35

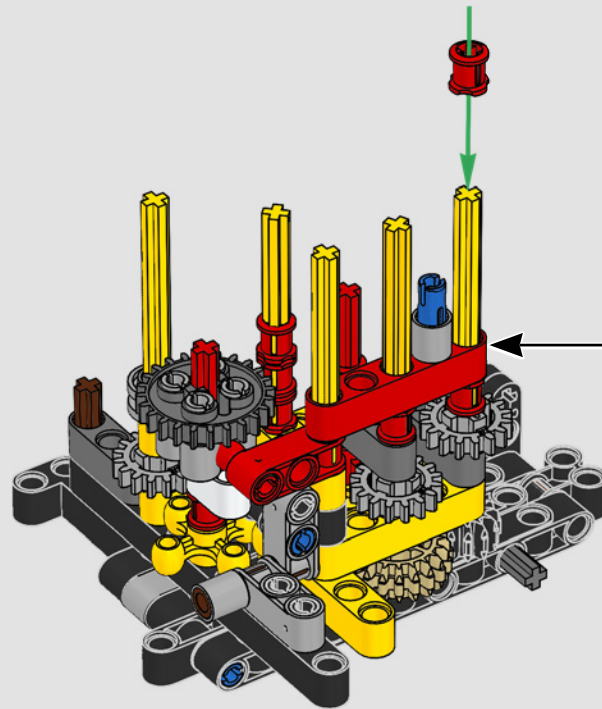

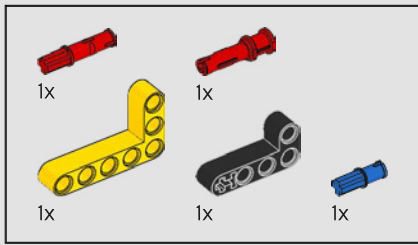

36

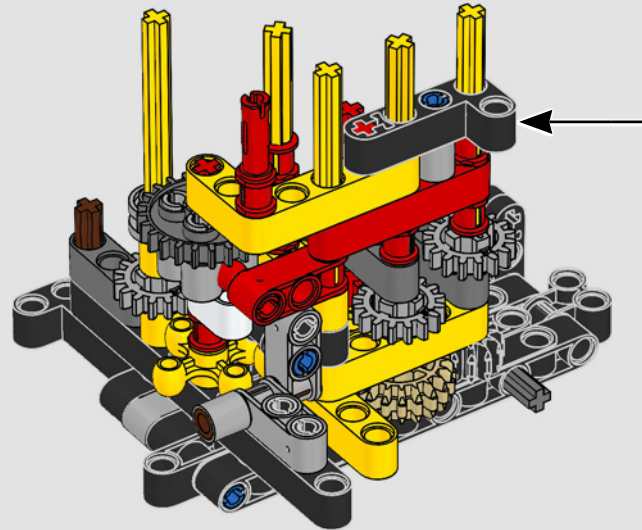
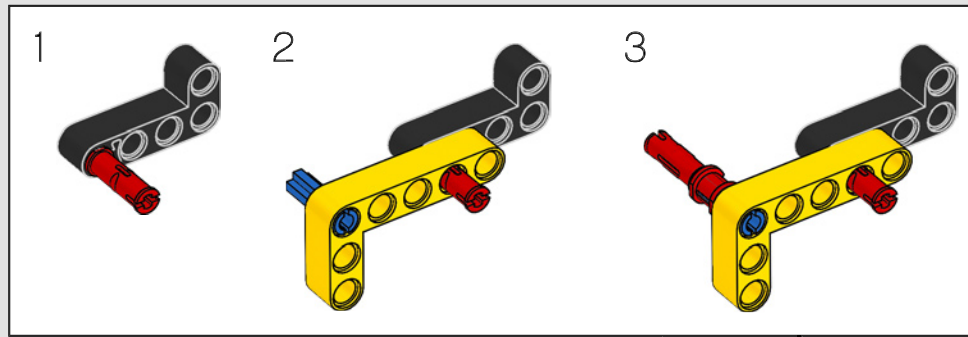

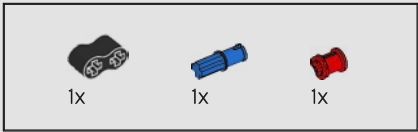

37

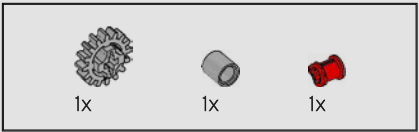
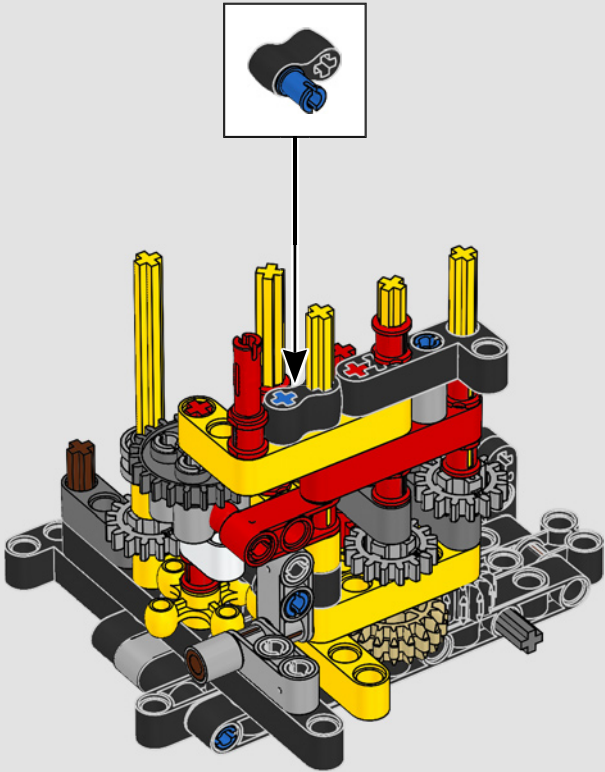

38

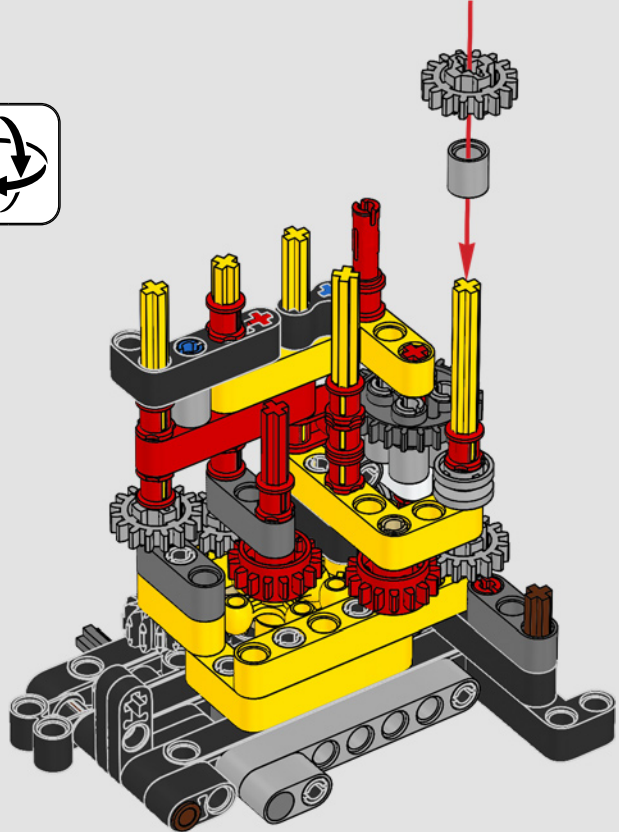

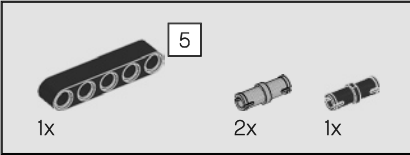
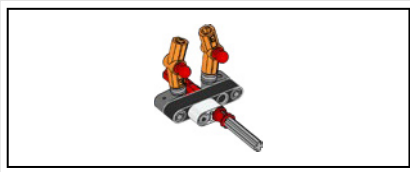

39

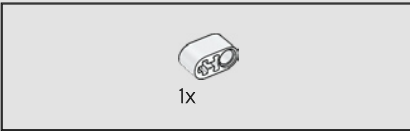
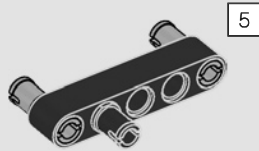

40

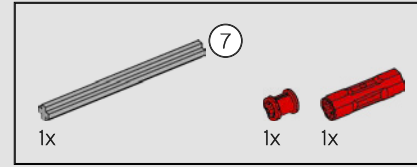
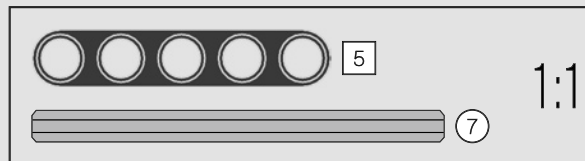

41

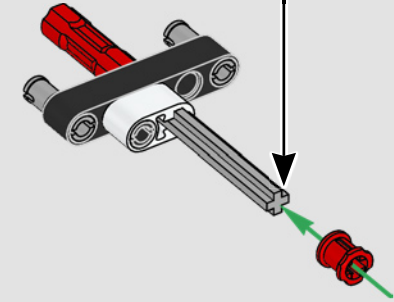
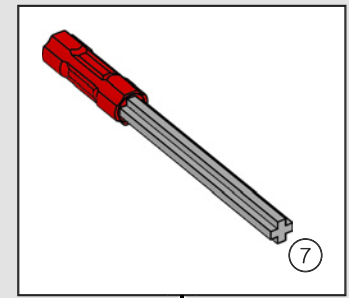

42

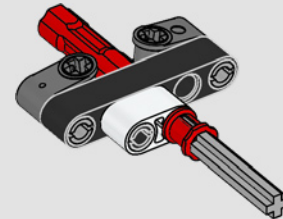

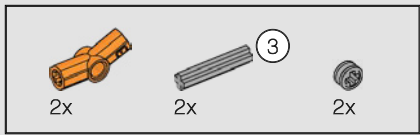

43

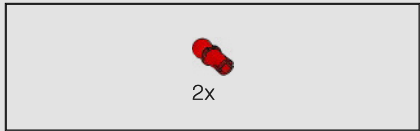
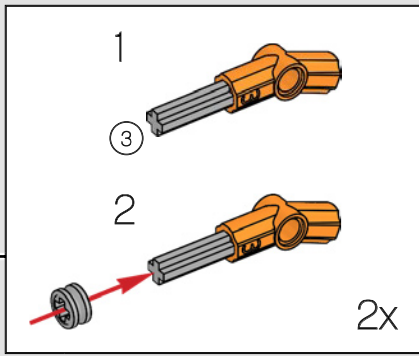
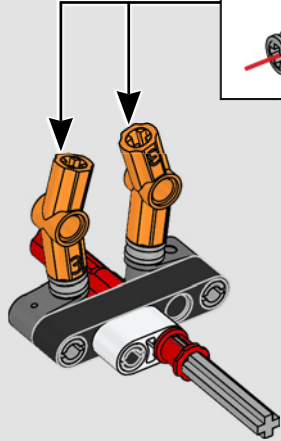

44

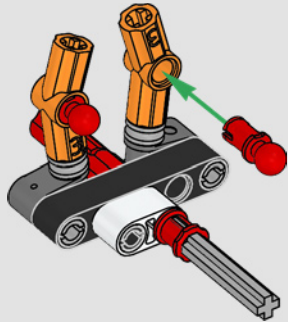

45

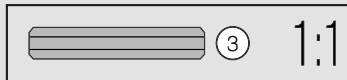
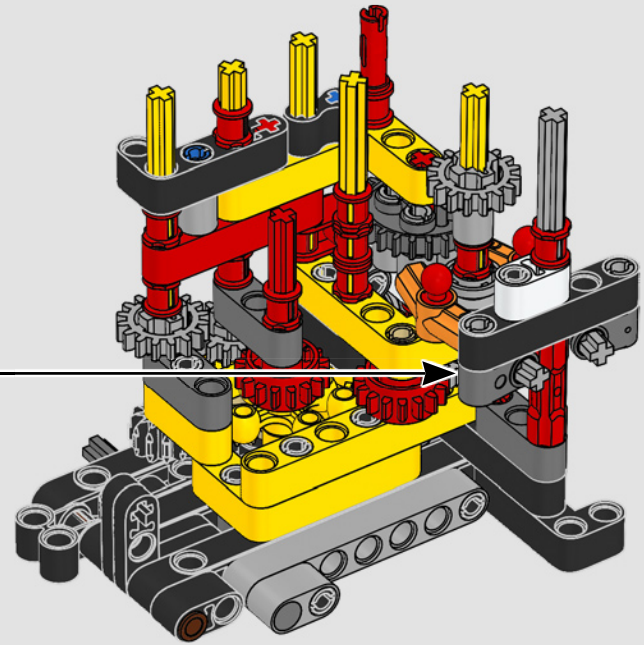



46

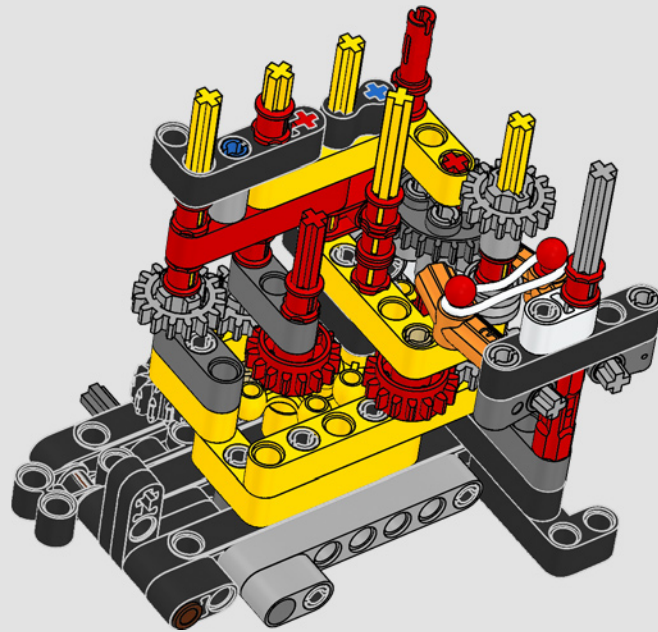

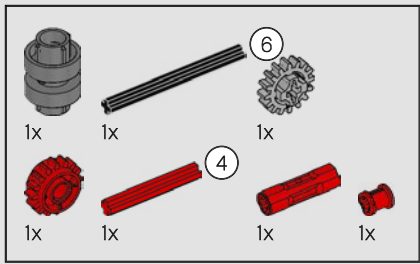

47

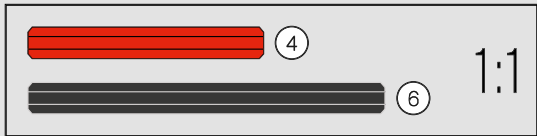
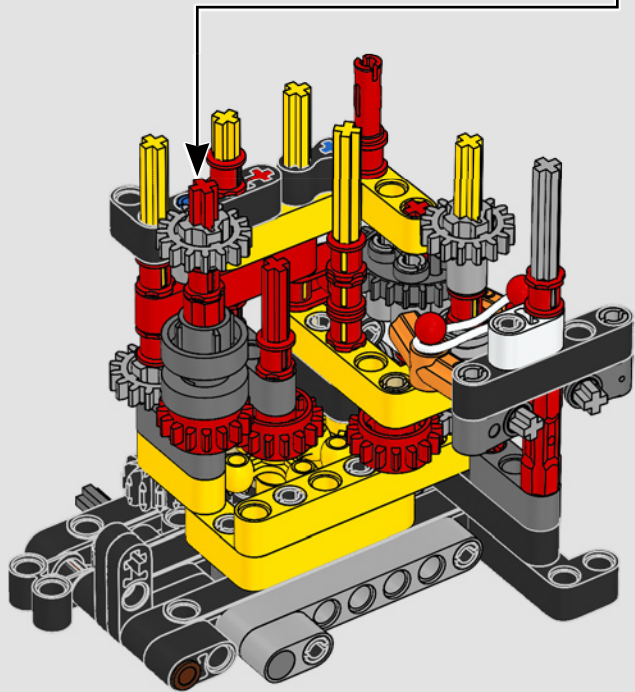
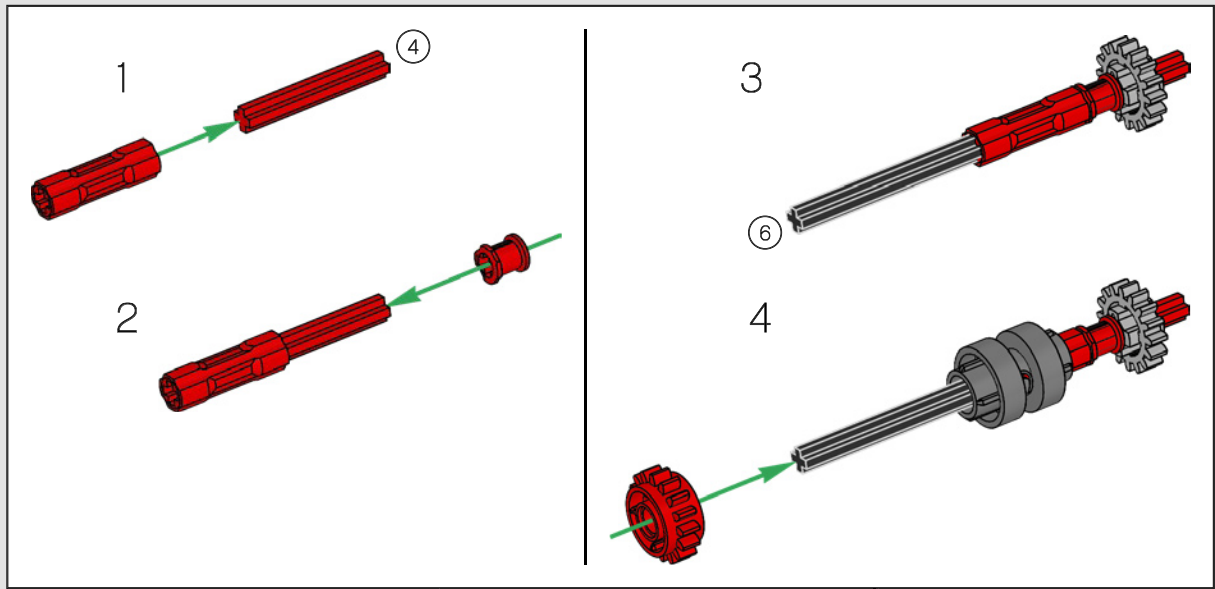



48

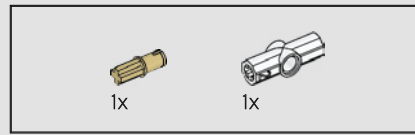
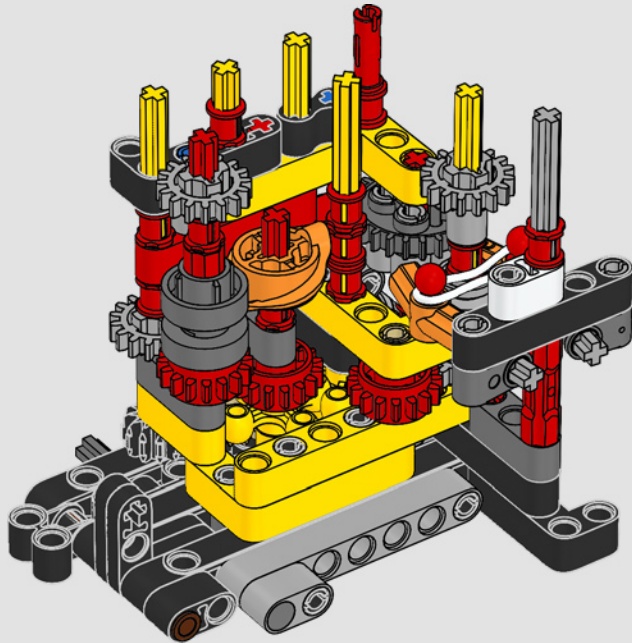
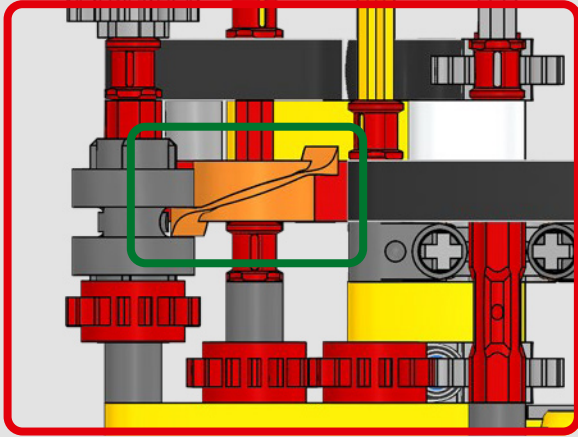

49

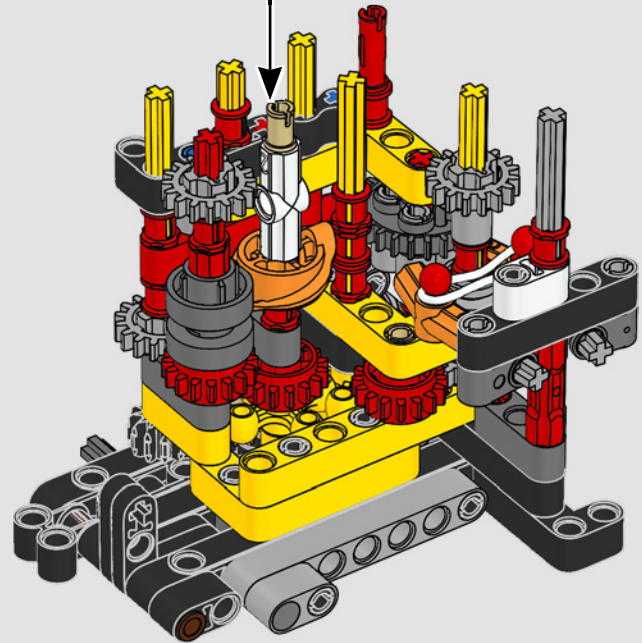
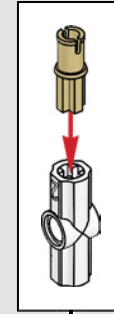



50

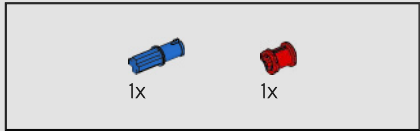
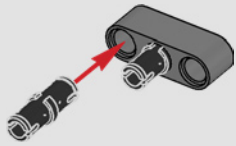

51

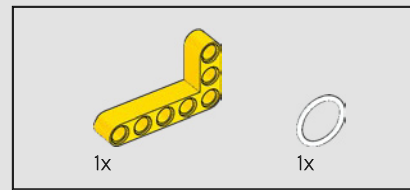
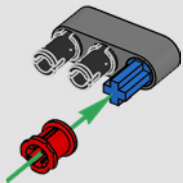

52

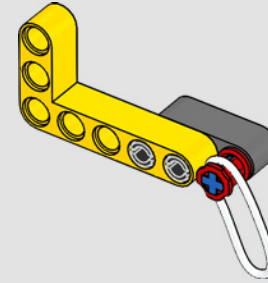

53

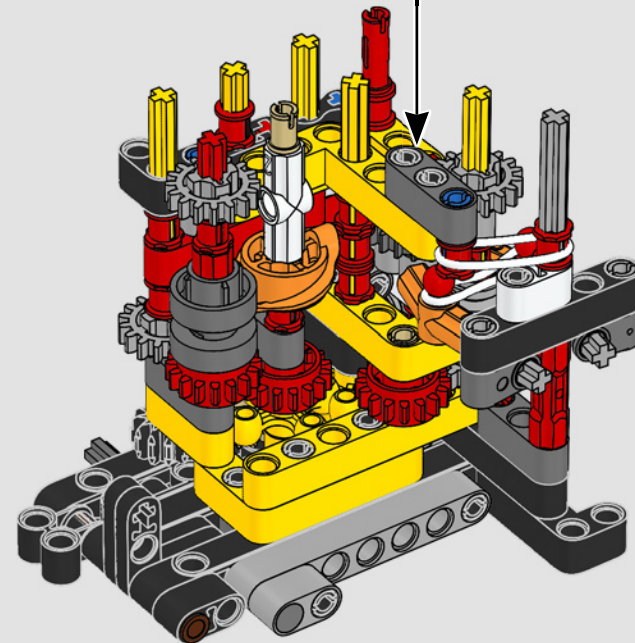

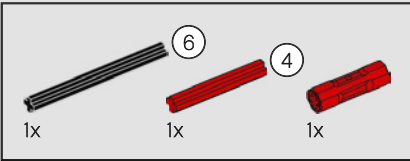
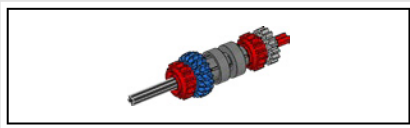

54

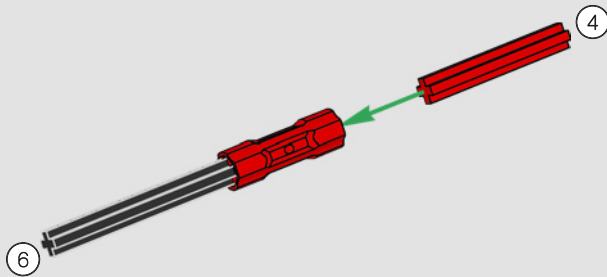

55

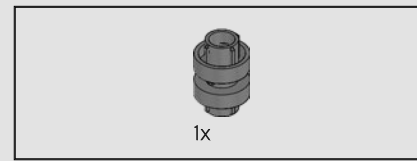
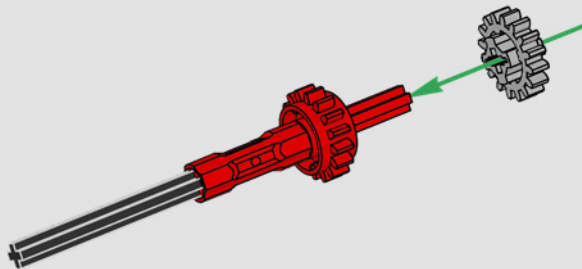

56

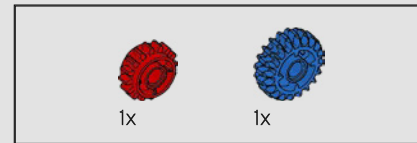
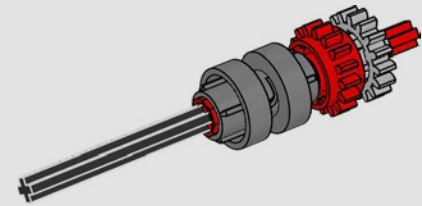

57

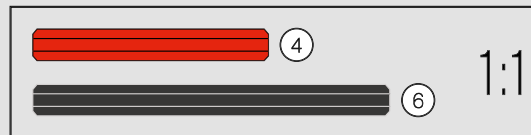
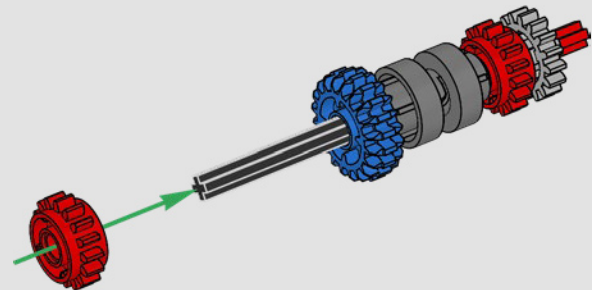

58

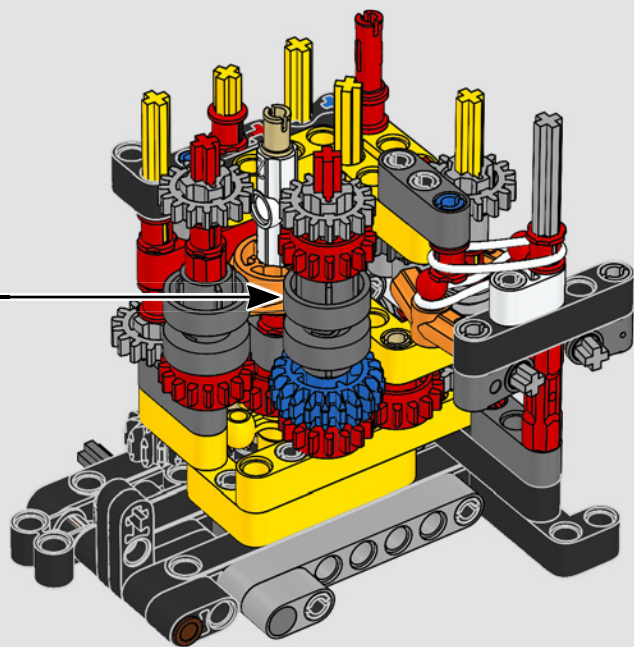

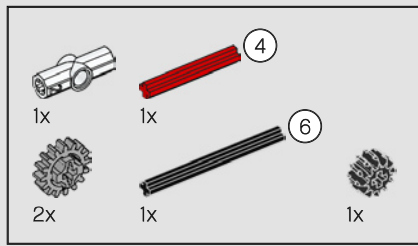

59

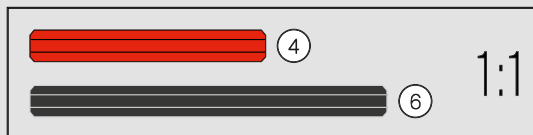
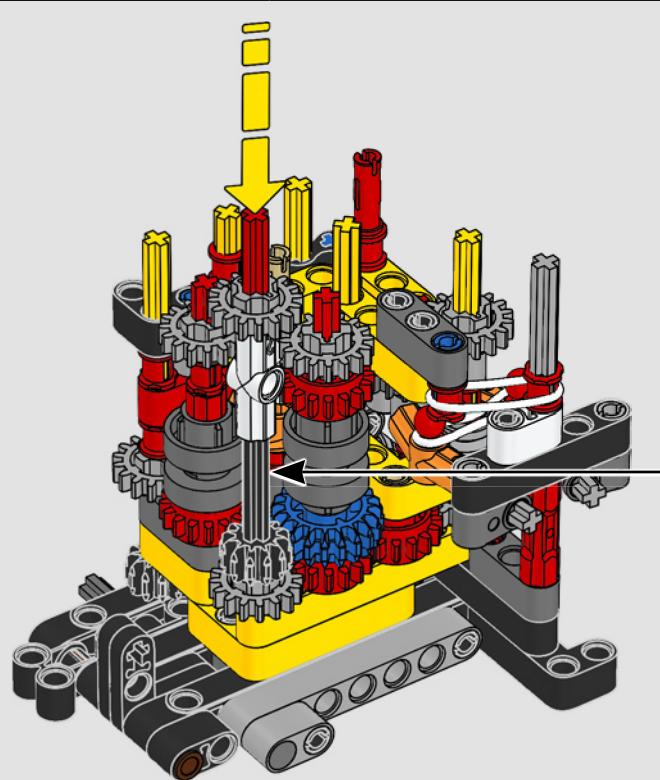
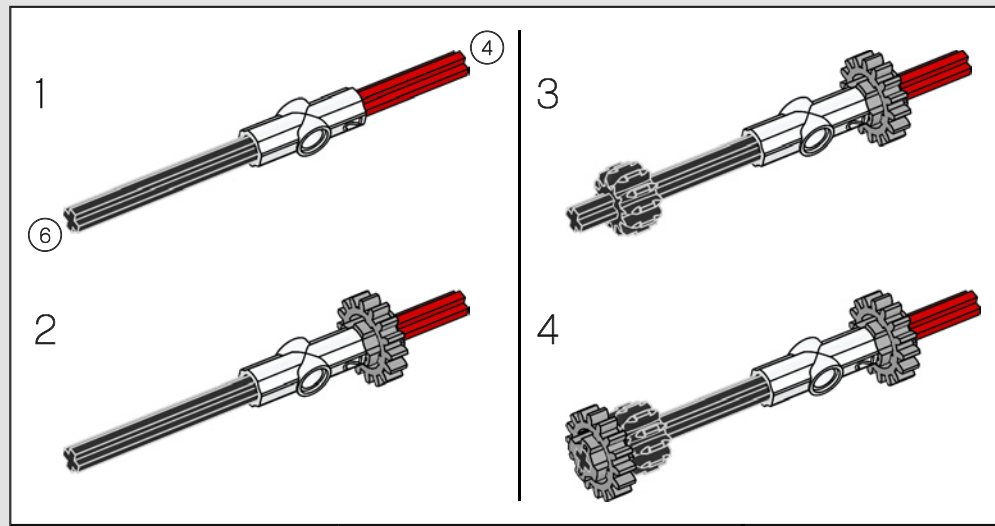

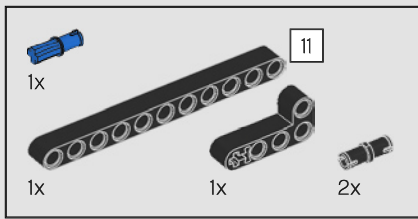

60

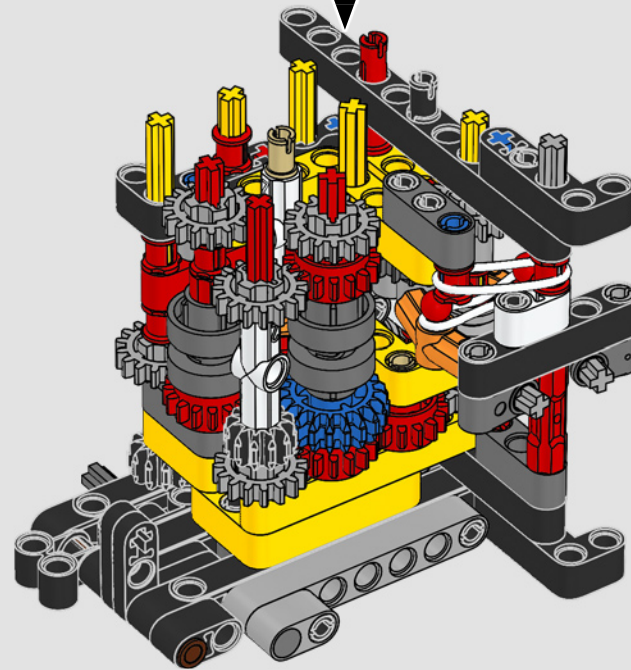
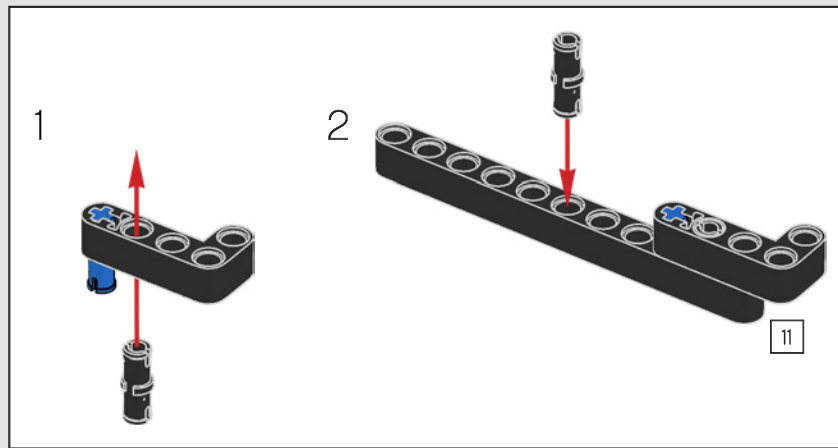

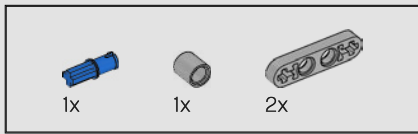

61

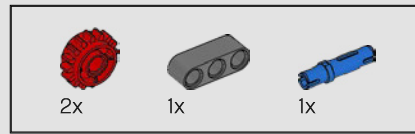
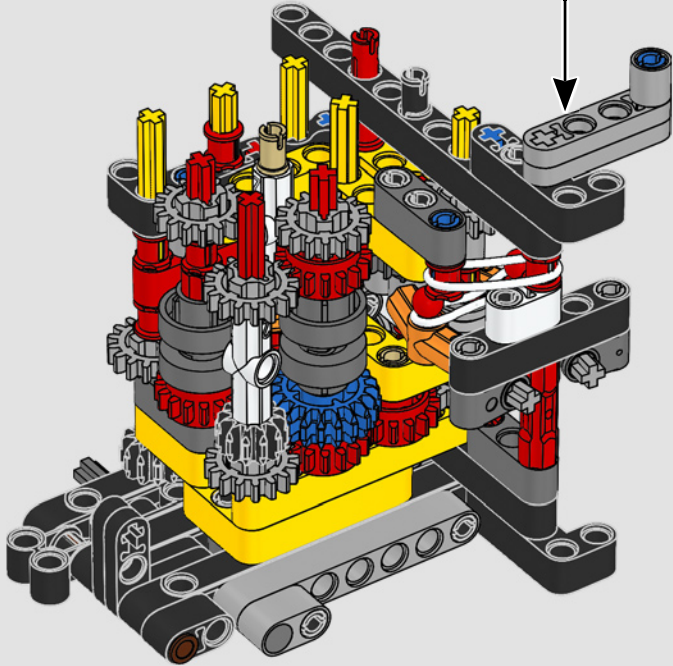
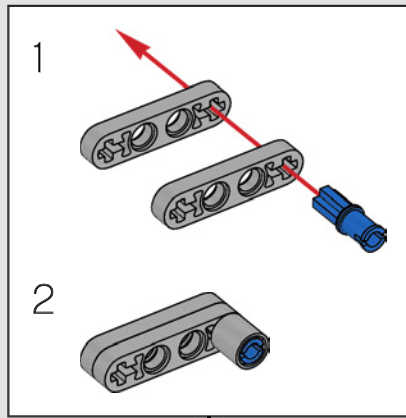

62

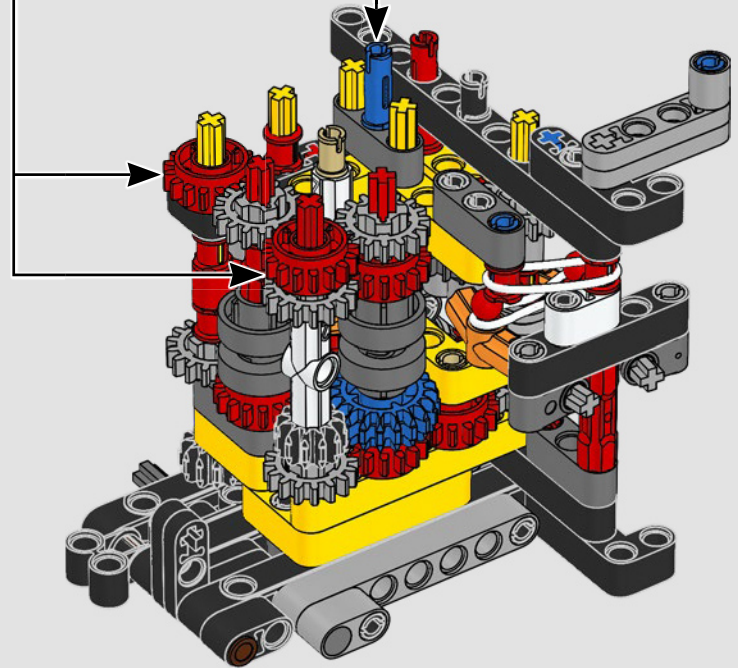
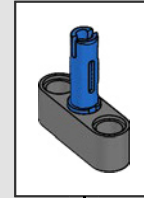
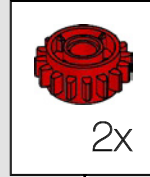

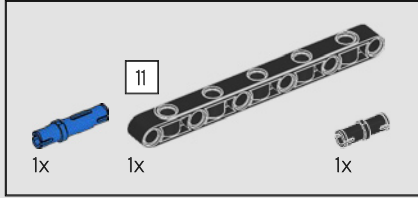
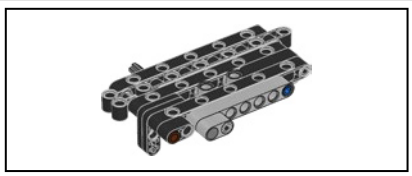

63

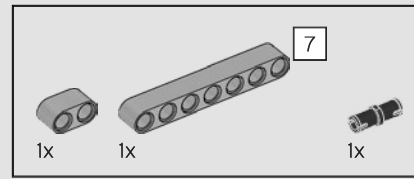
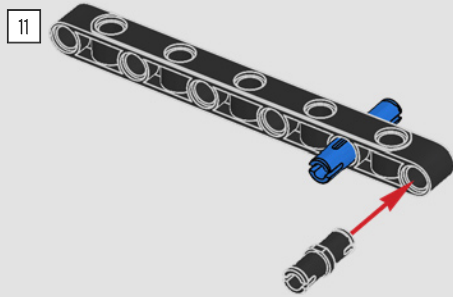

64

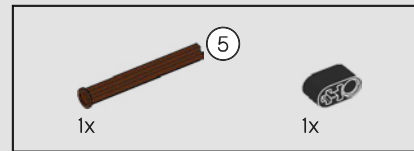
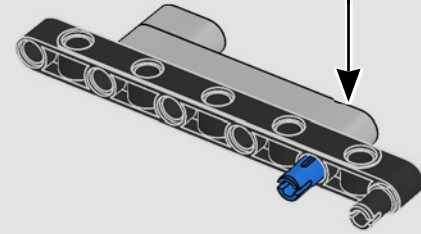
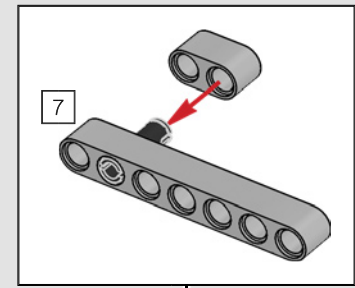

65

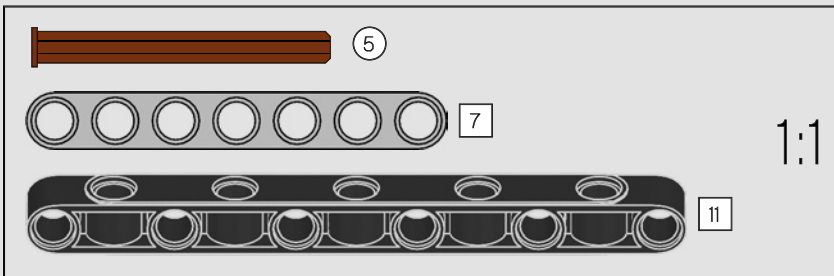
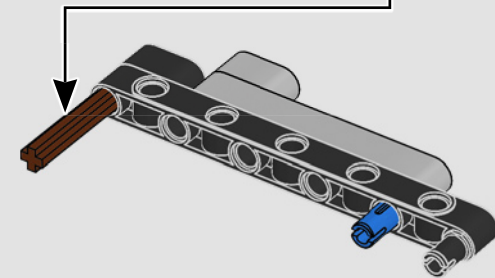
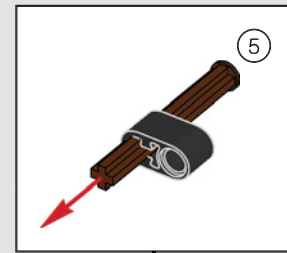



66

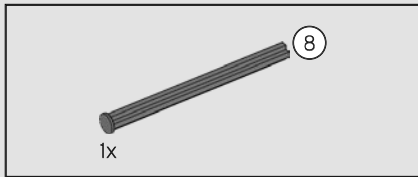
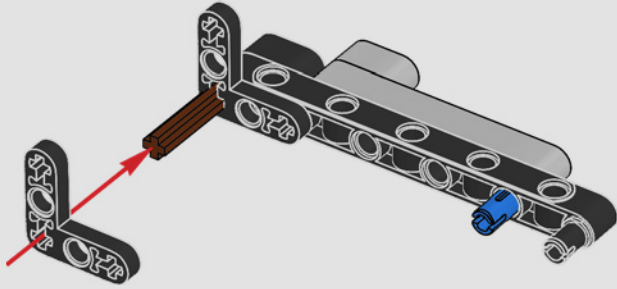

67

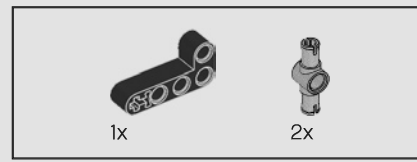
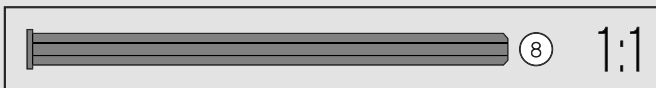
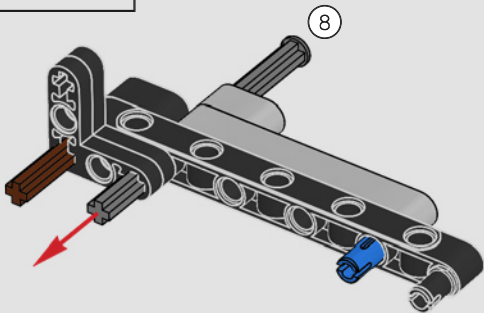

68

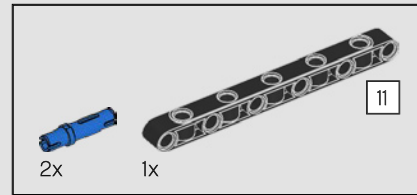
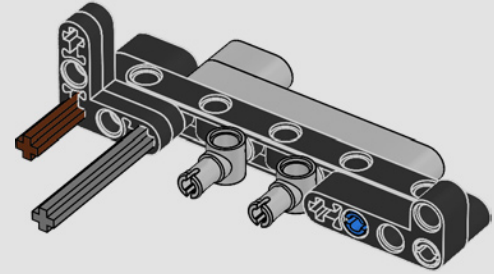

69

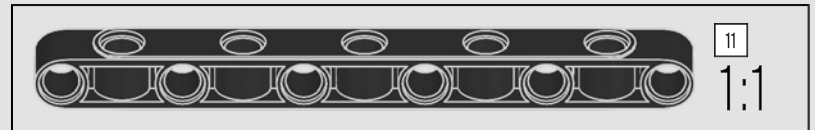
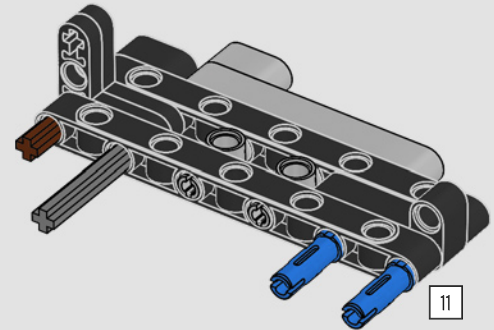

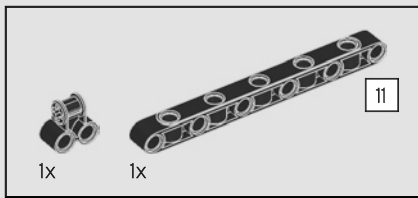

70

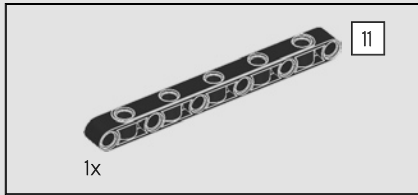
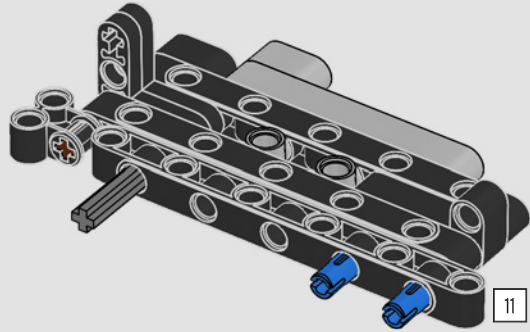

71

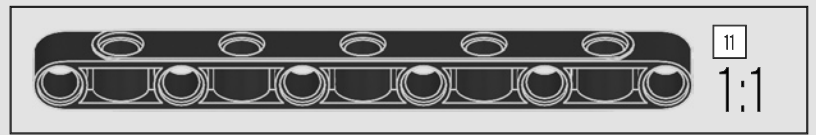
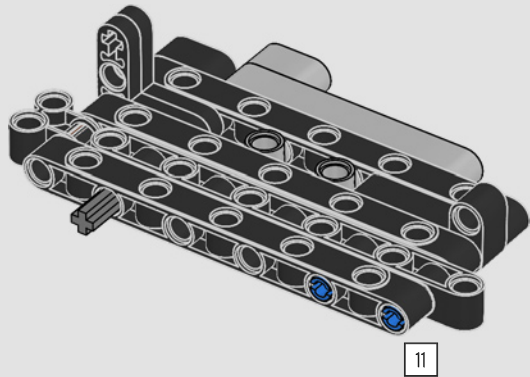

72

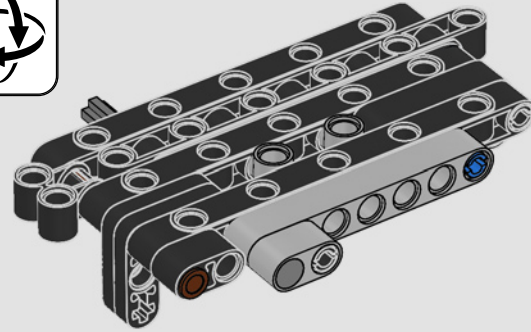
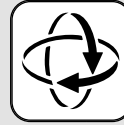

73

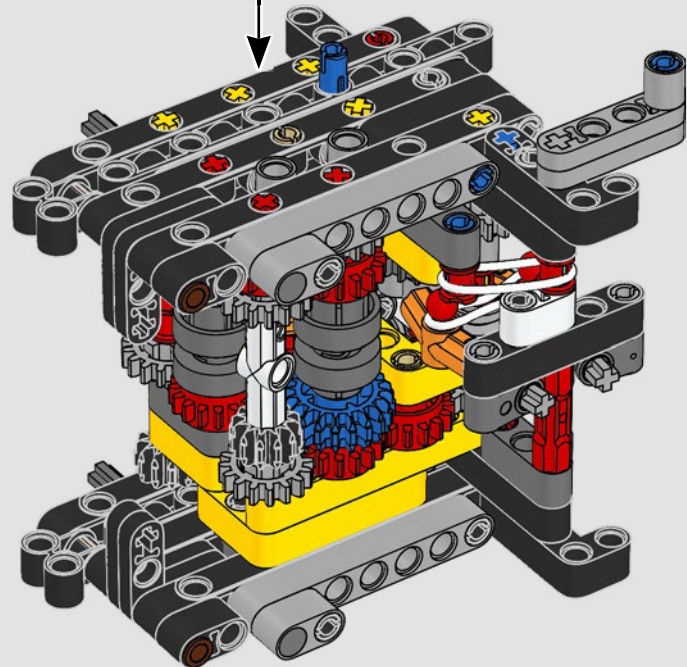

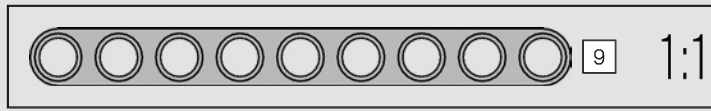
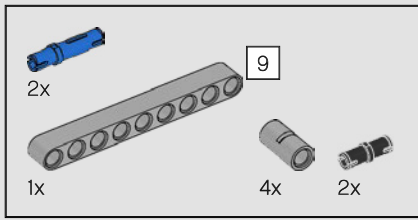

74

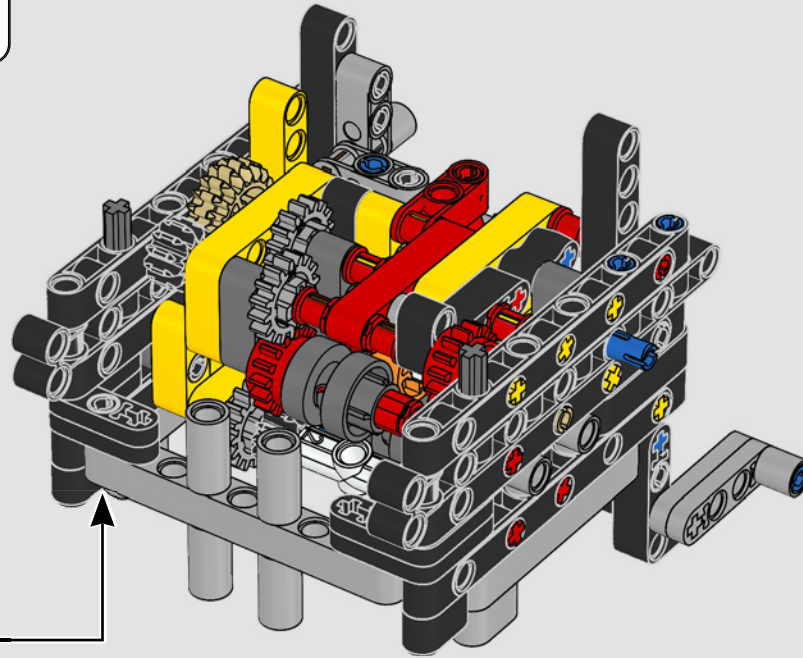
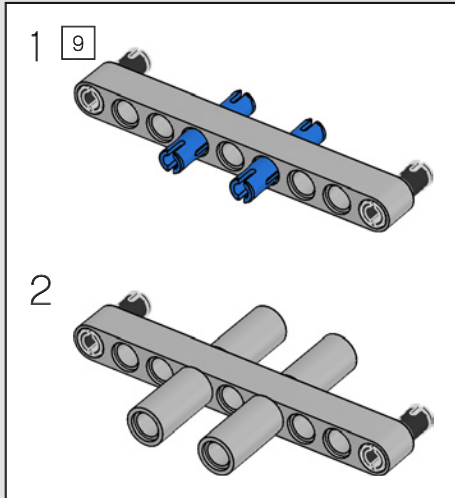

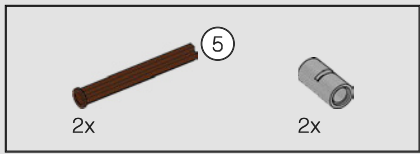

75

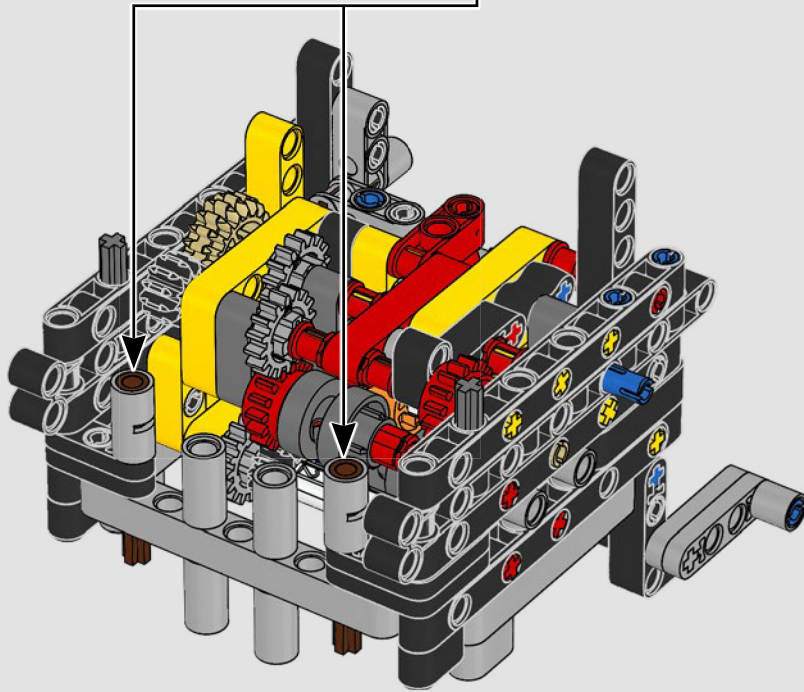
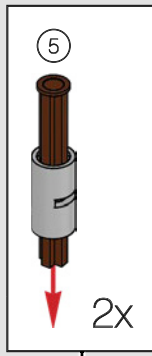

76

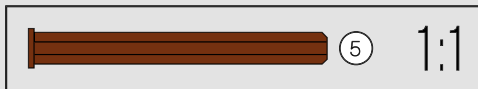
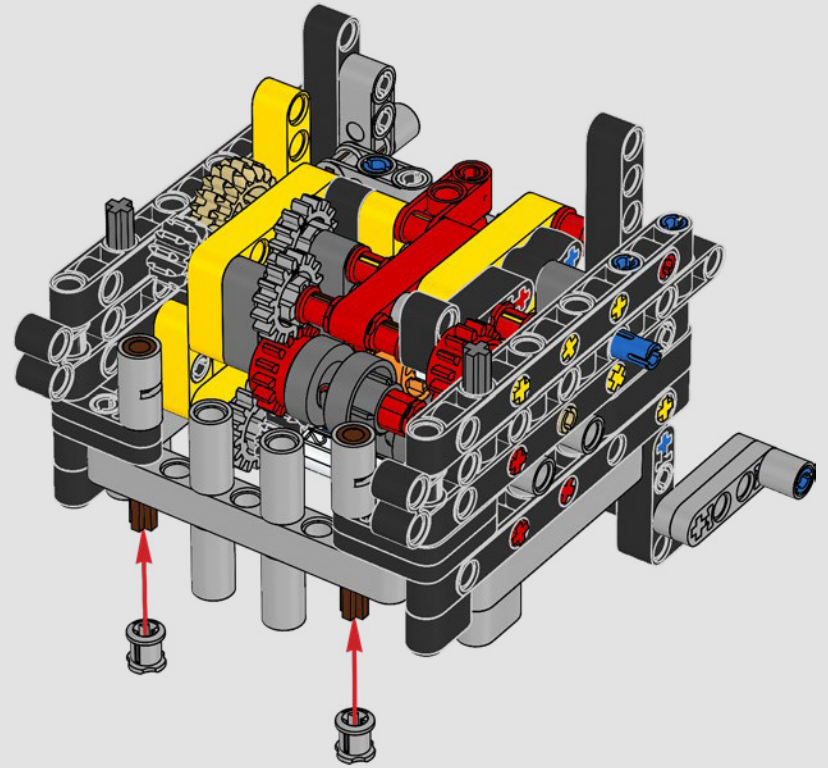

62x

77

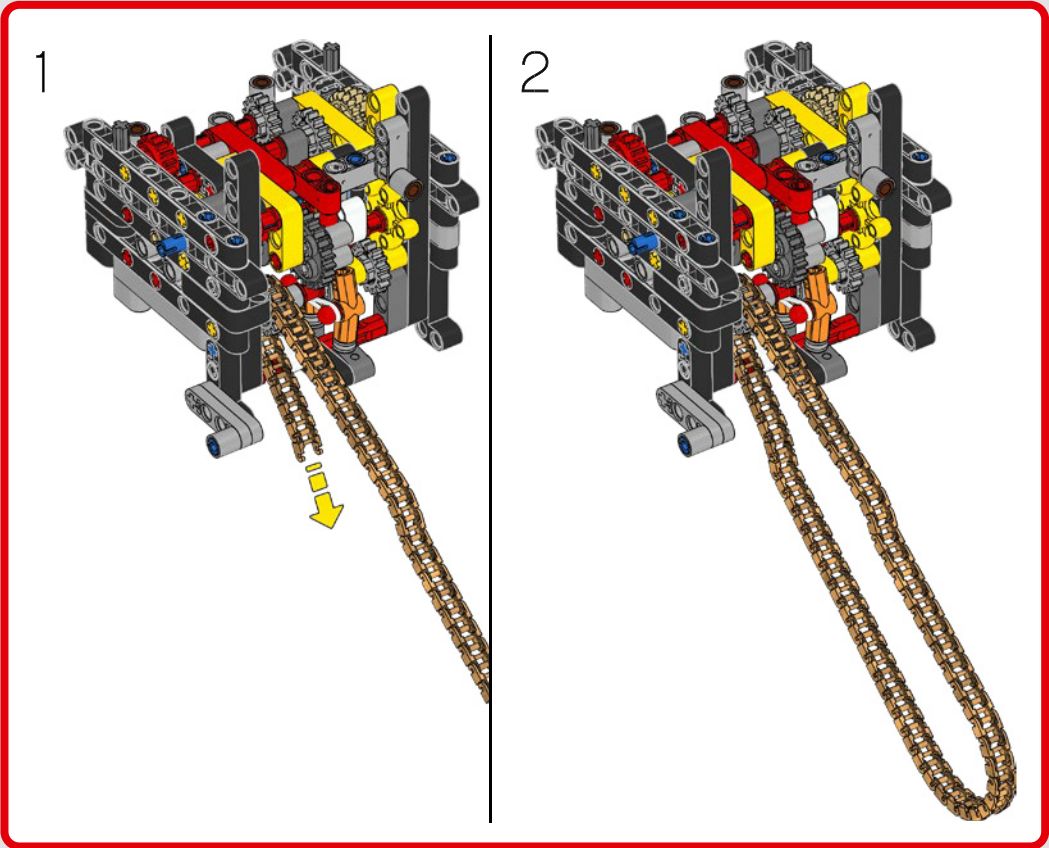
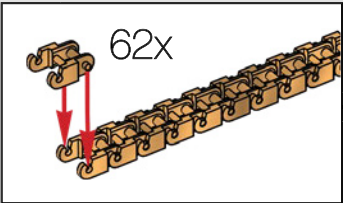
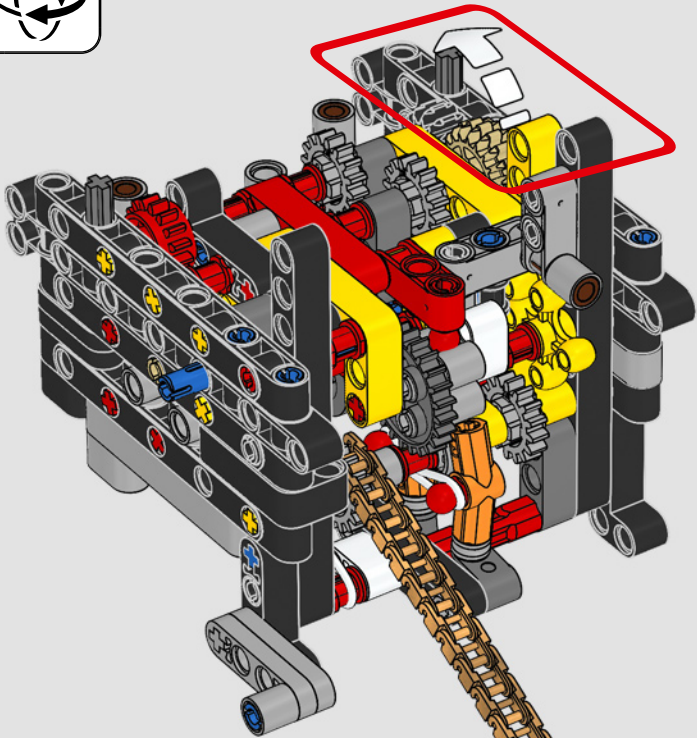

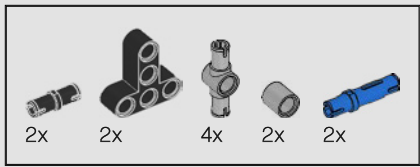

78

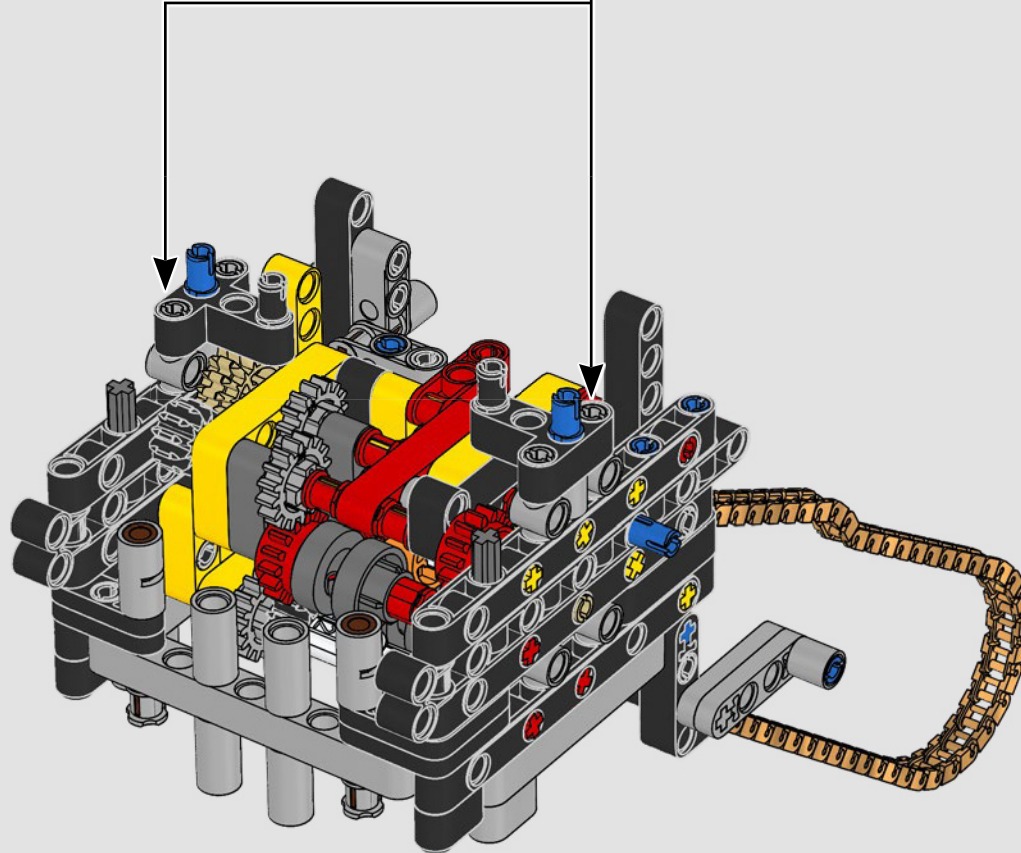
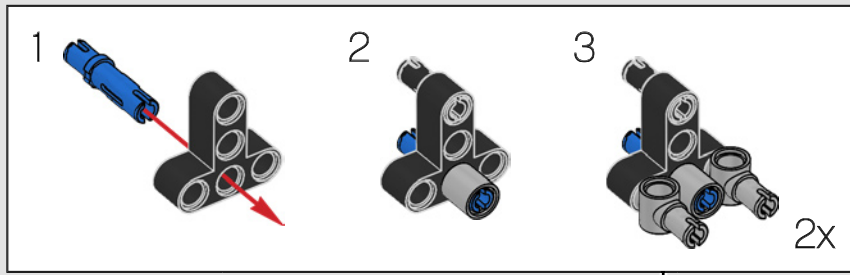

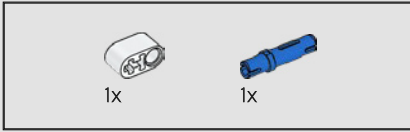
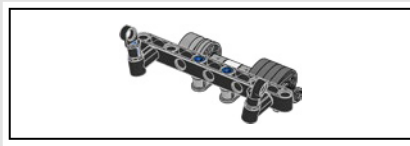

79

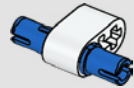

80

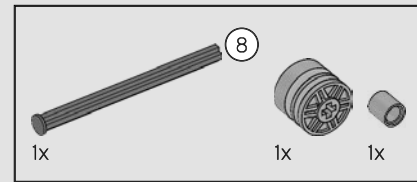
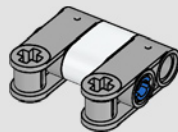

81

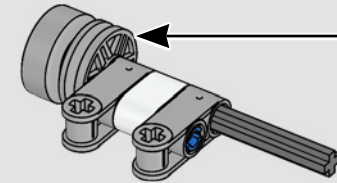
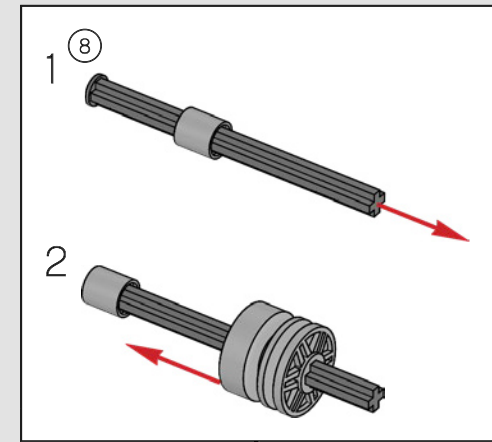

82

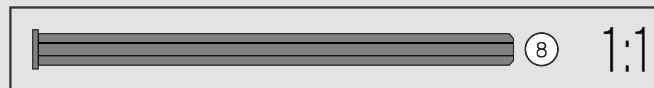
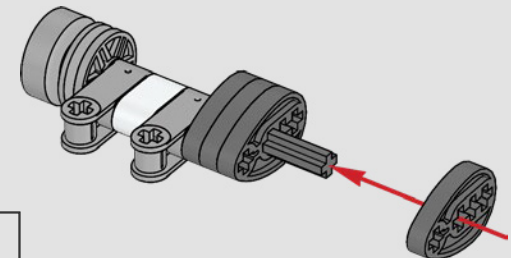

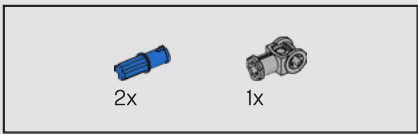

83

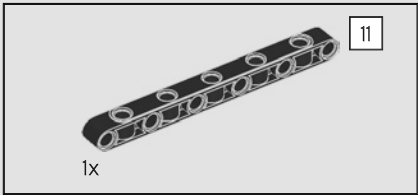
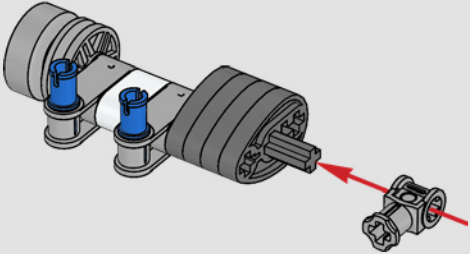

84

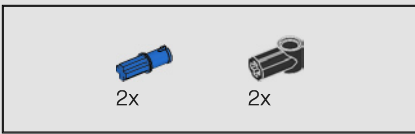
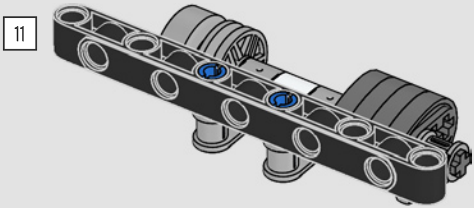

85

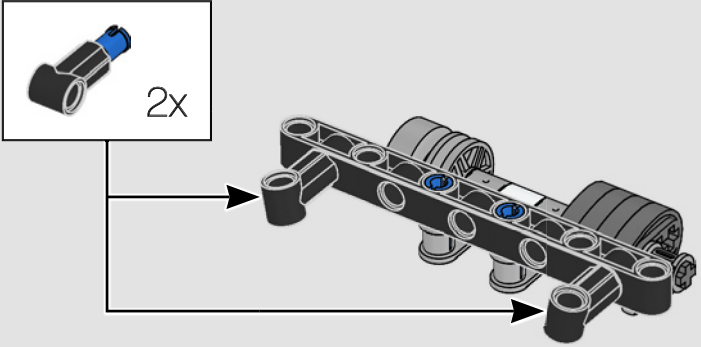

86

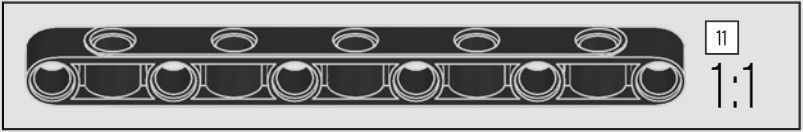
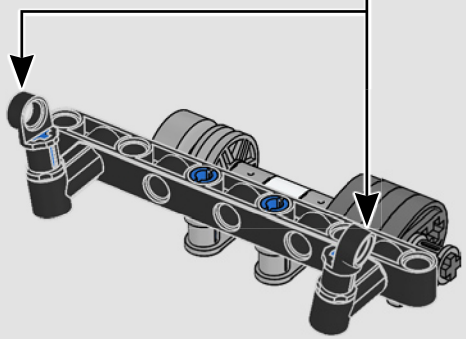
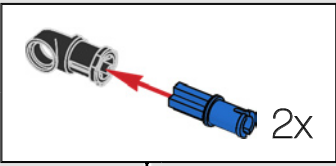

87

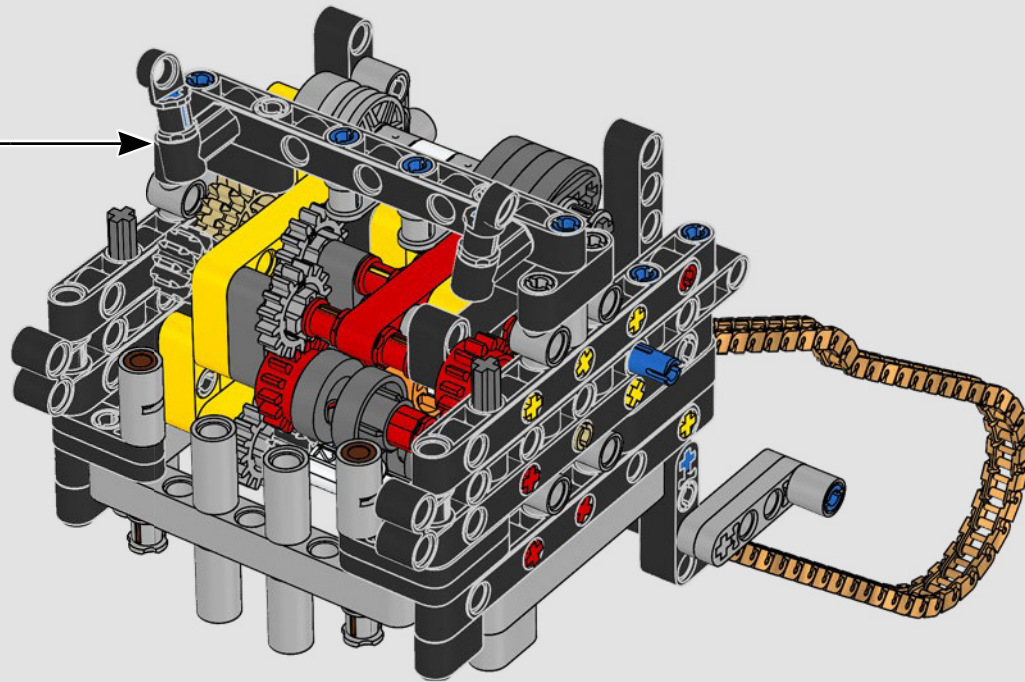

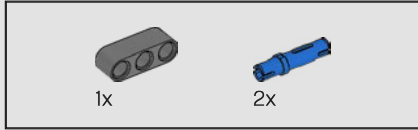
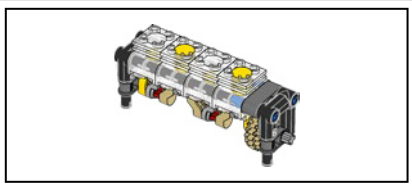

88

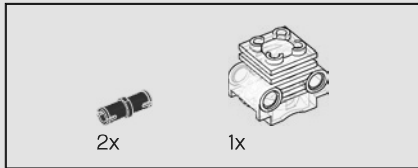
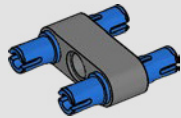

89

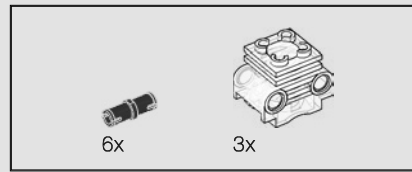
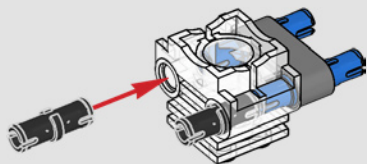

90

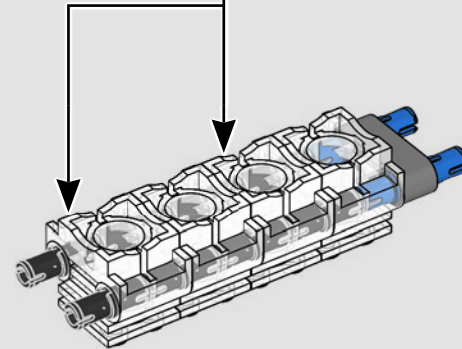
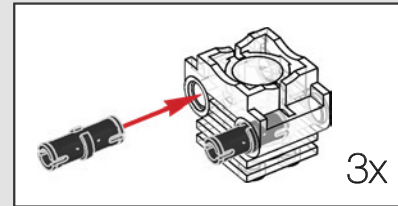

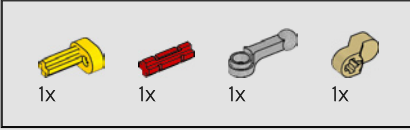
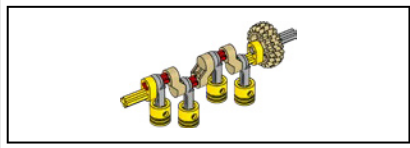

91

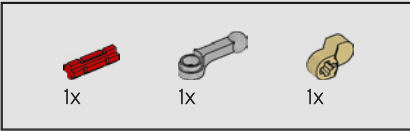
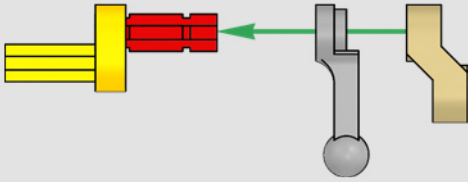

92

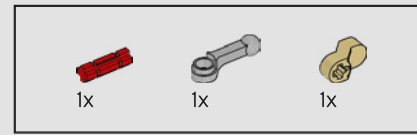
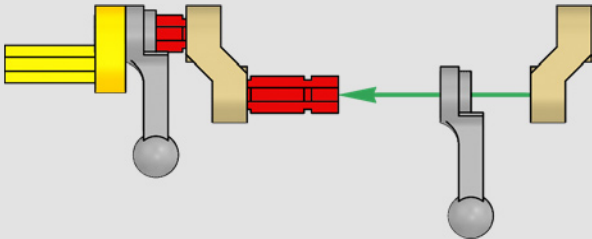

93

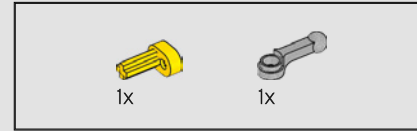
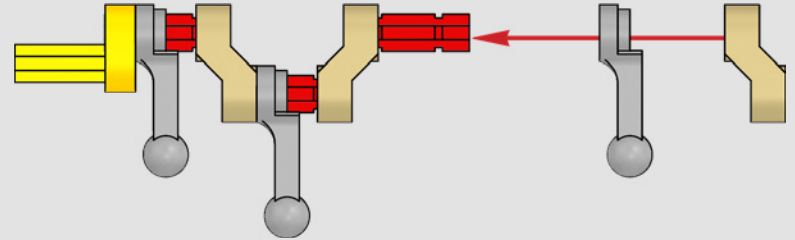

94

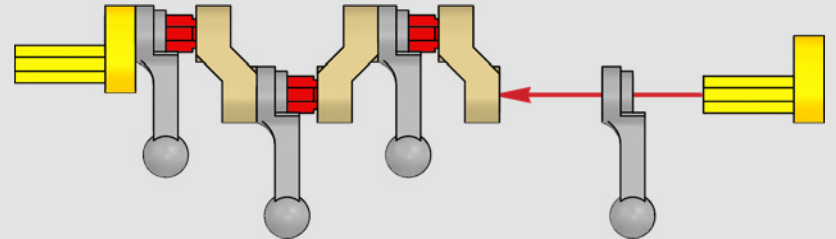



4x

95

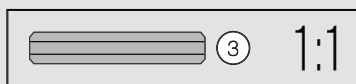
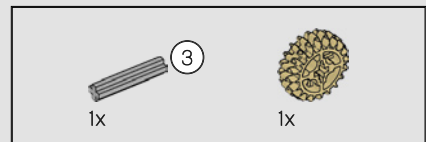
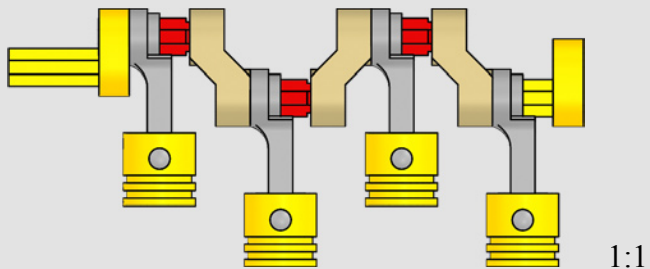

96

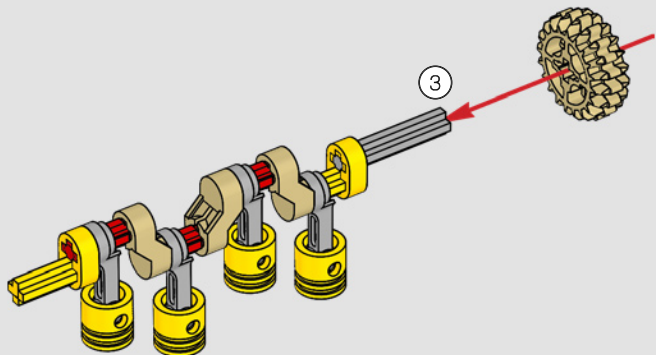

97

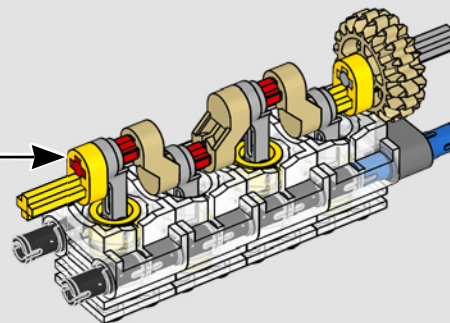

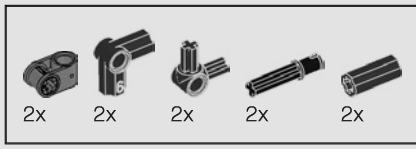

98

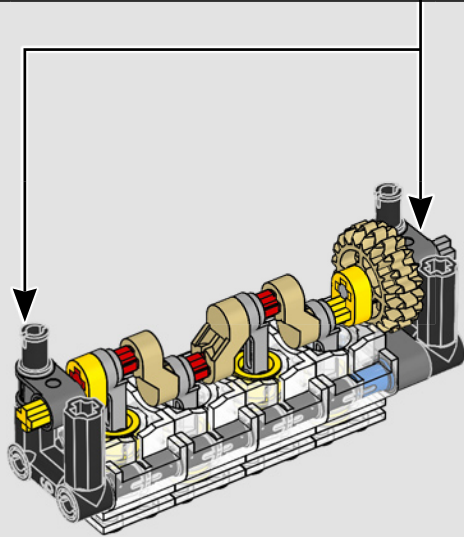
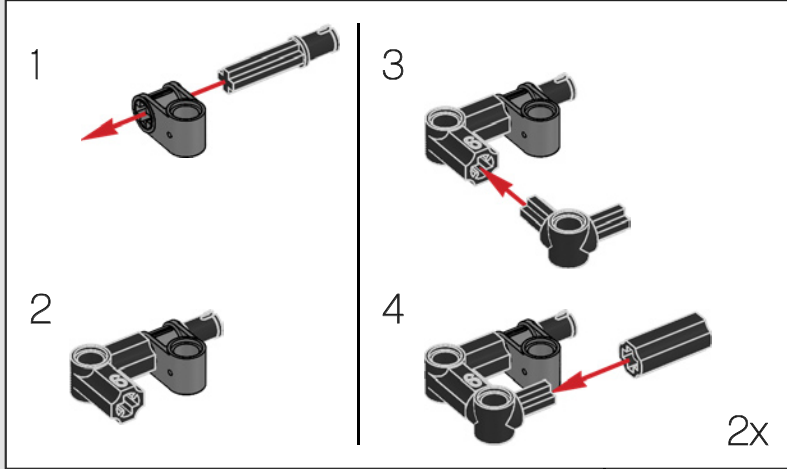

99

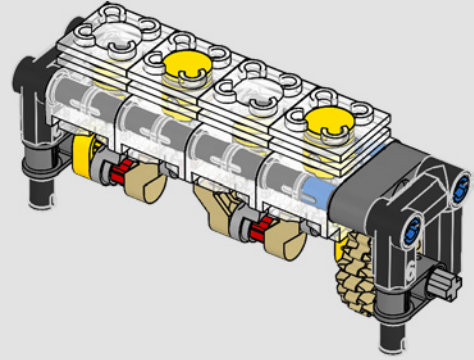
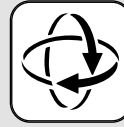

100

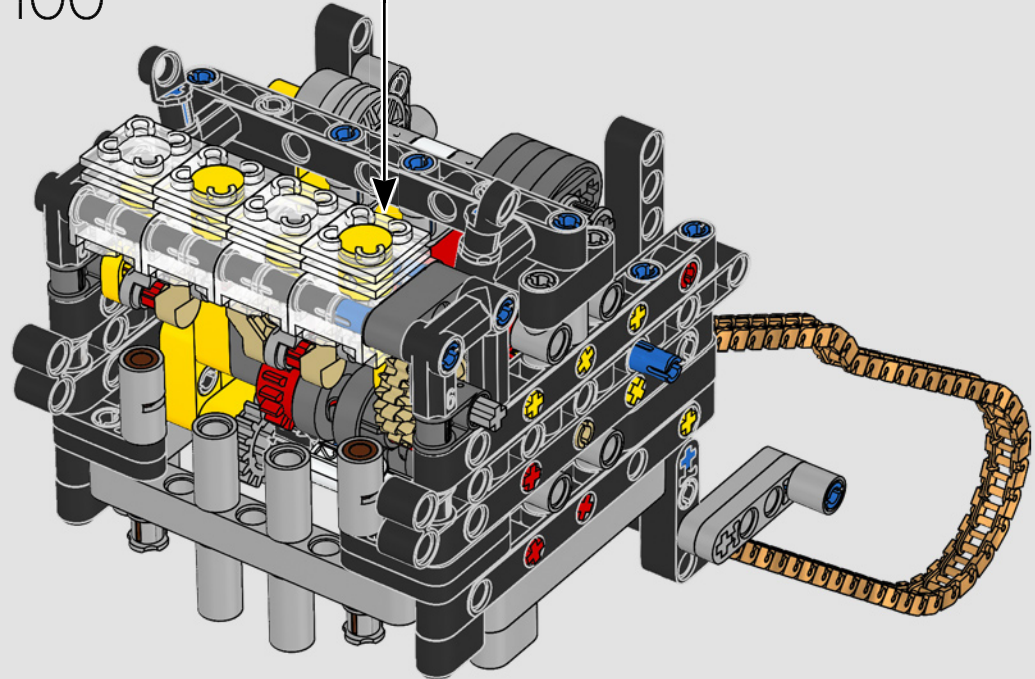

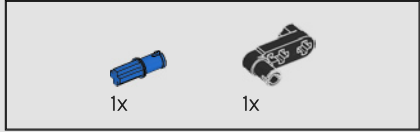
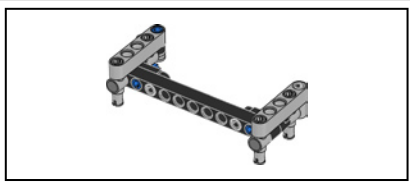

101

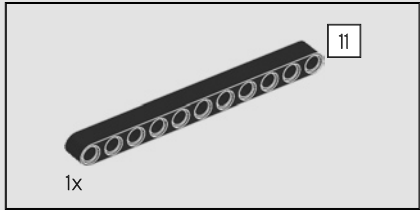

102

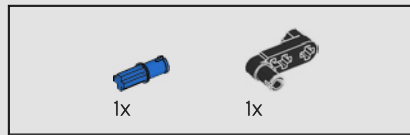
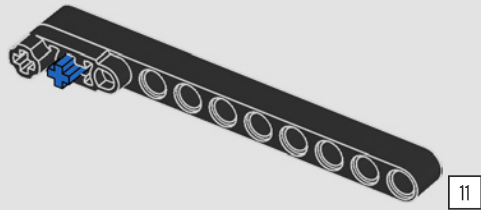

103

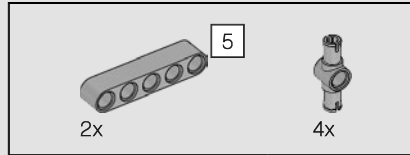
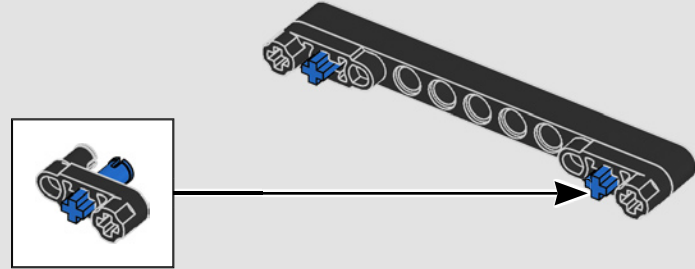

104

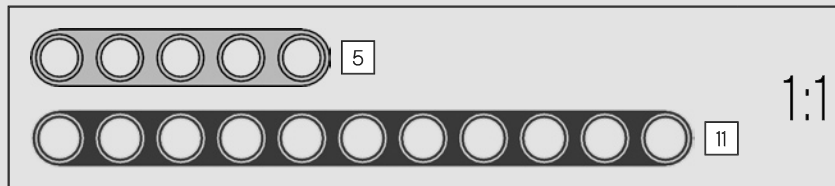
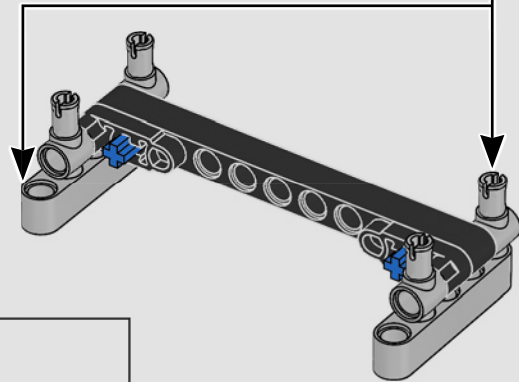
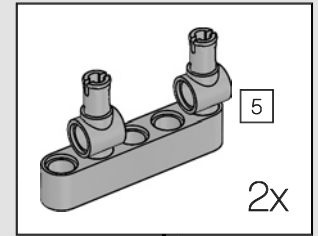

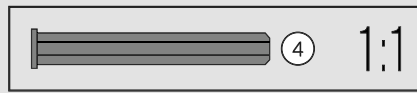
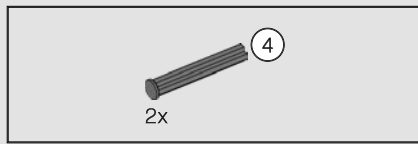

105

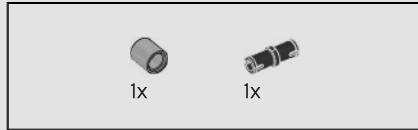
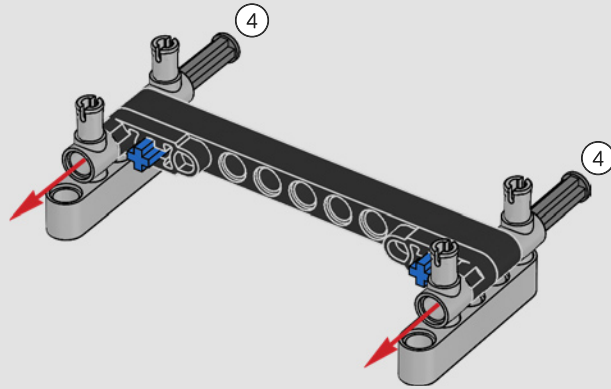

106

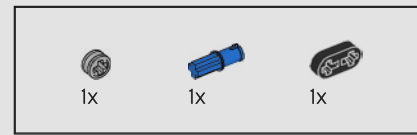
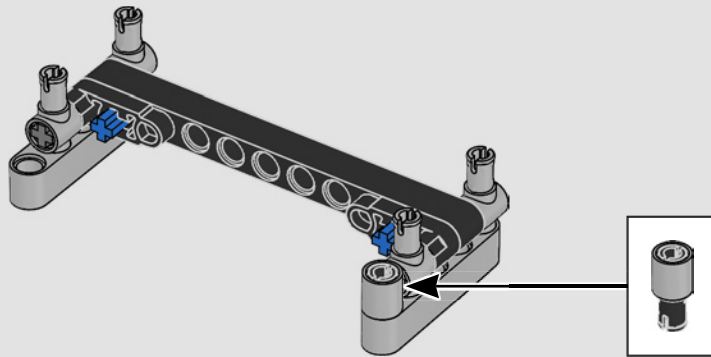

107

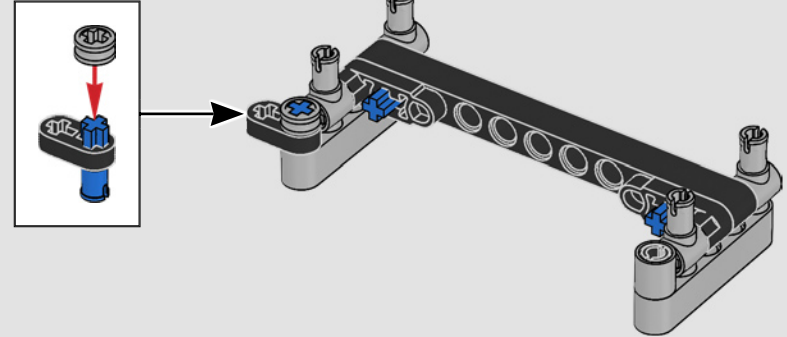

108

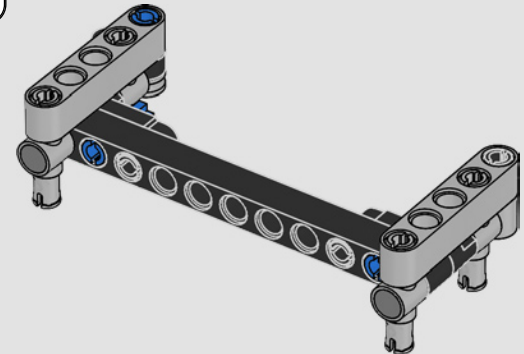
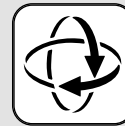

109

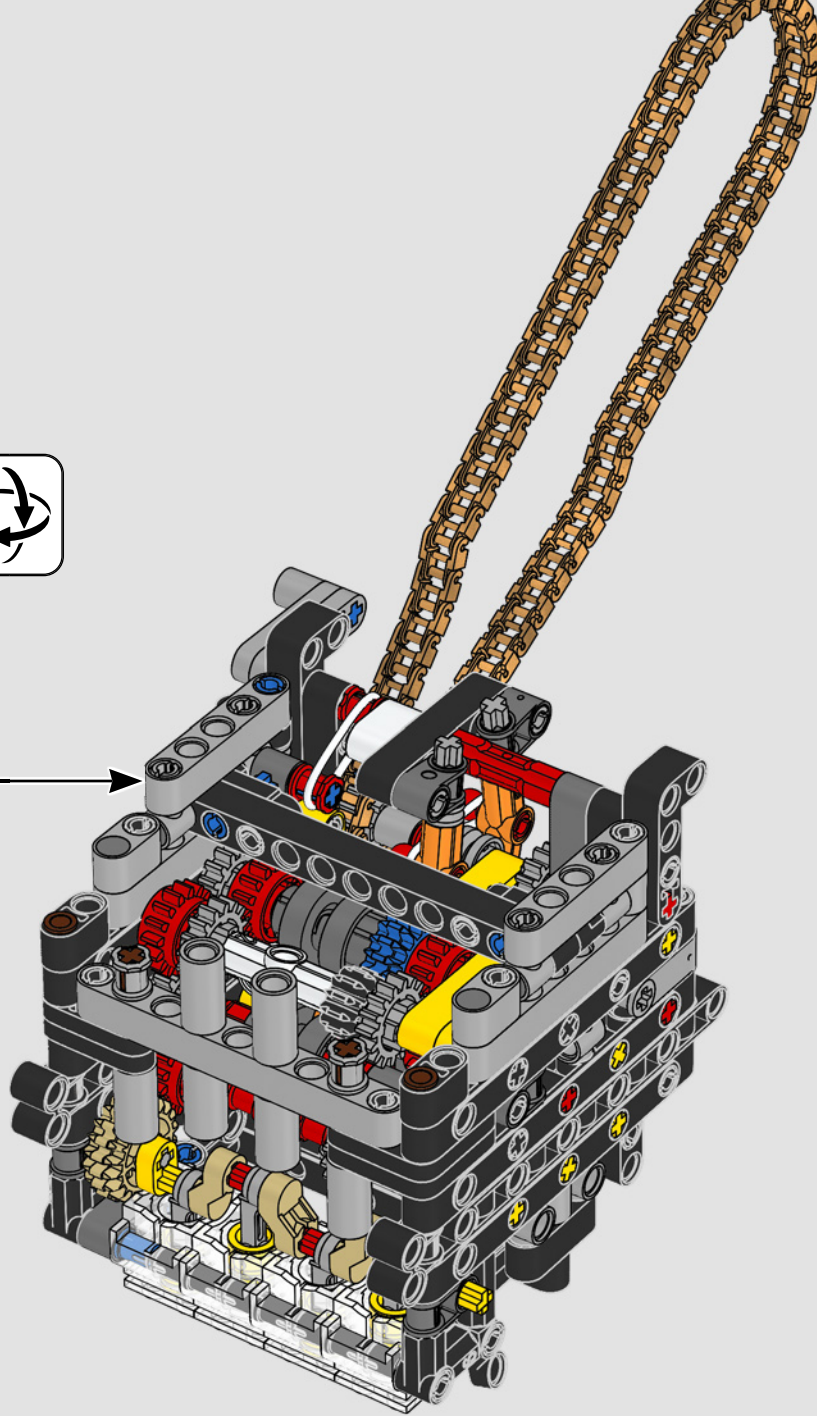

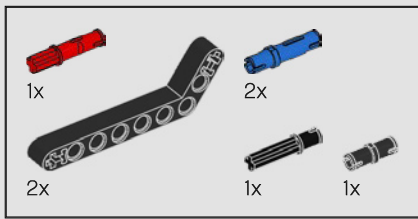

110

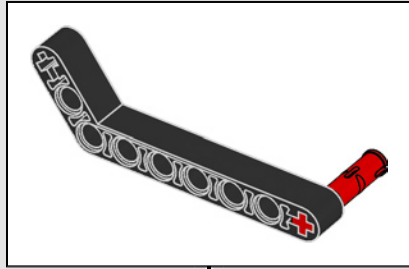

1

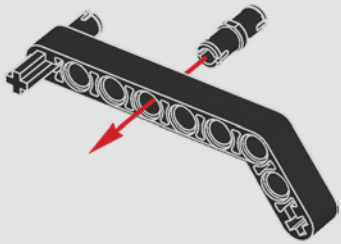

2

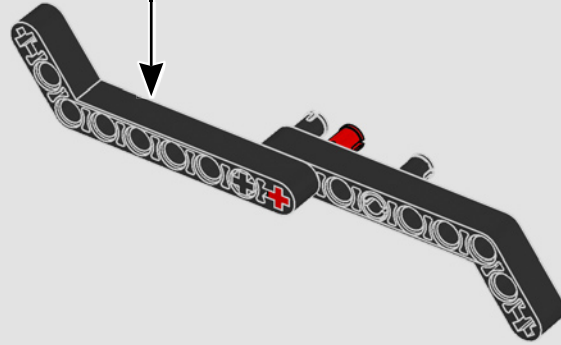

3

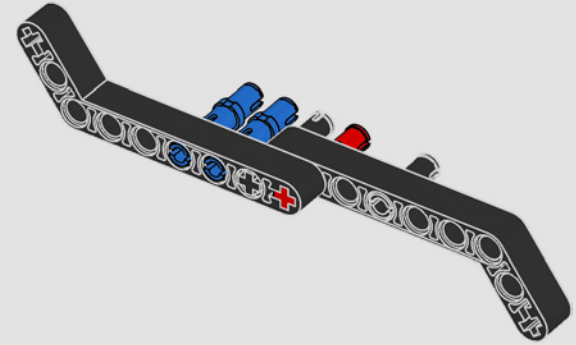

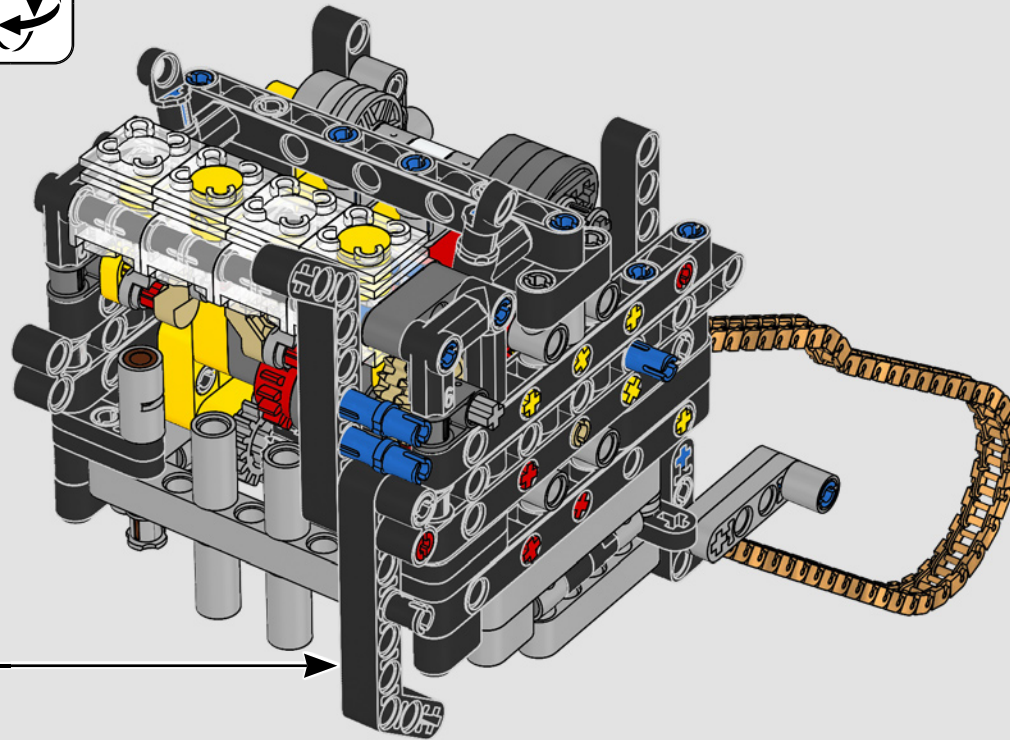

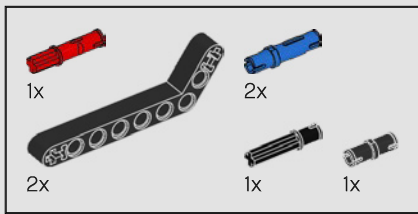

111

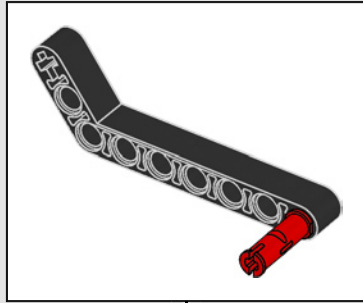

1

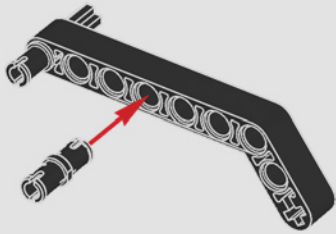

2

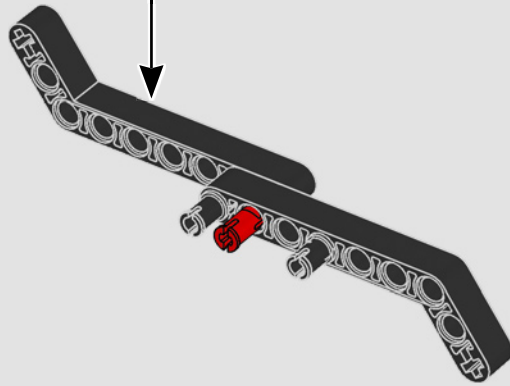

3

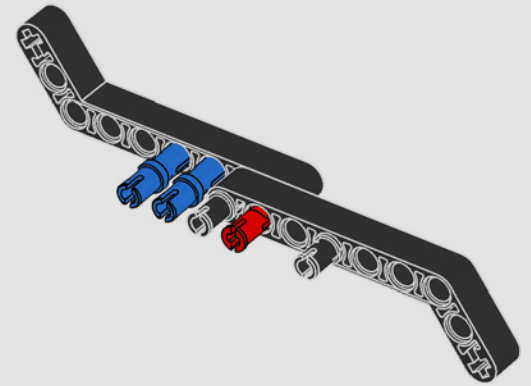

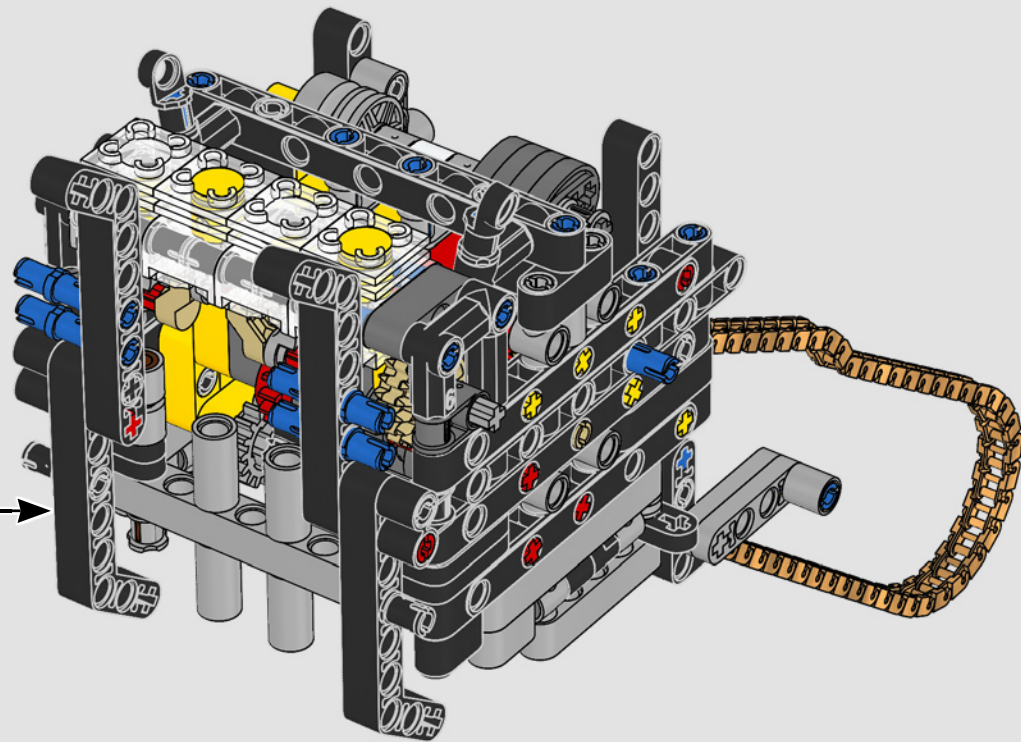

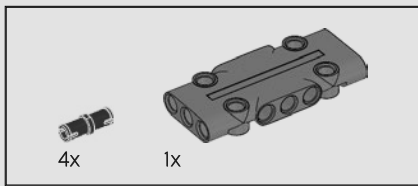

112

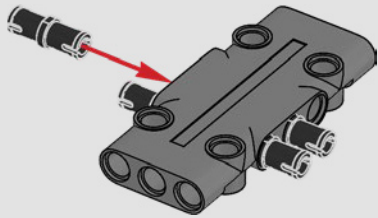

113

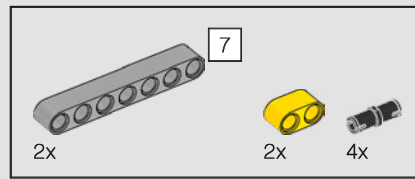
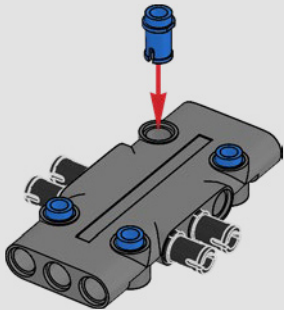

114

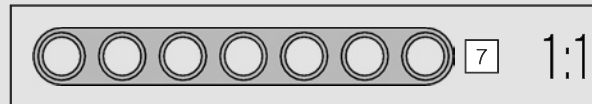
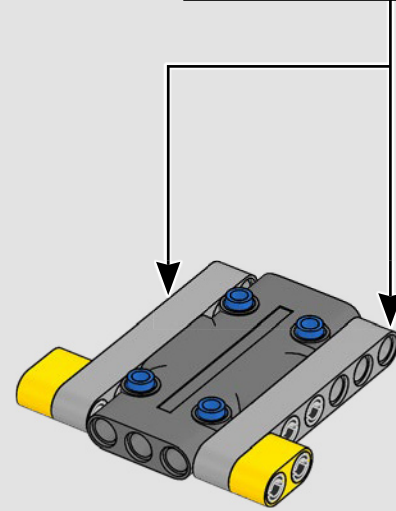
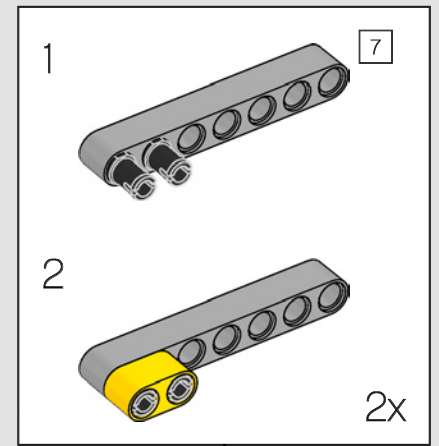

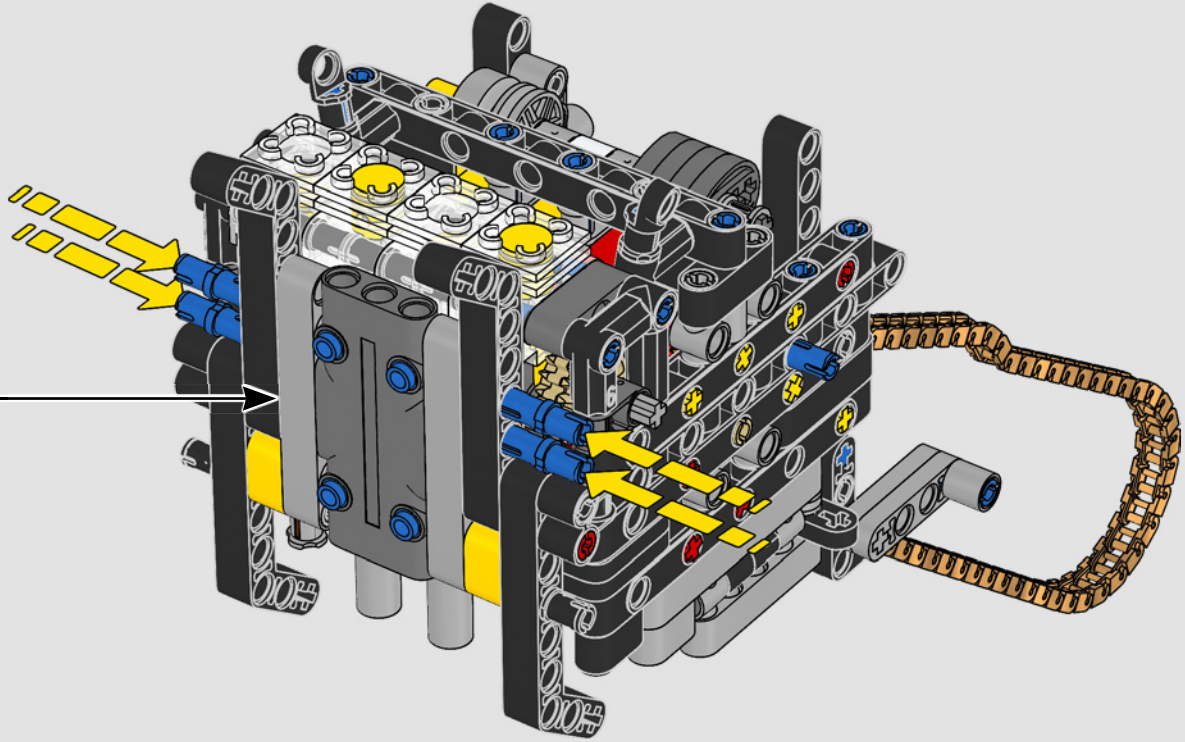

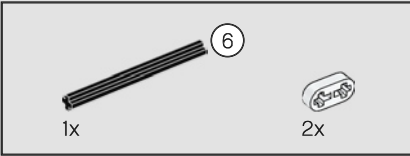
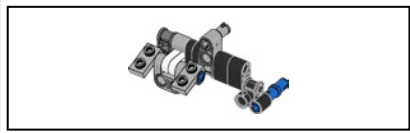

116

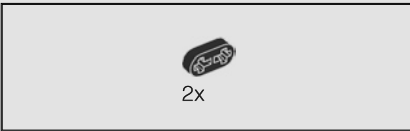
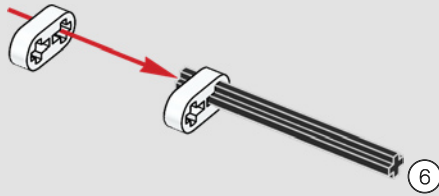

117

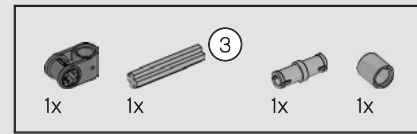
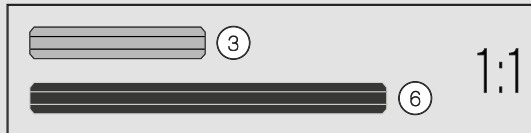
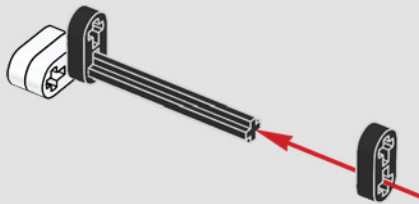

118

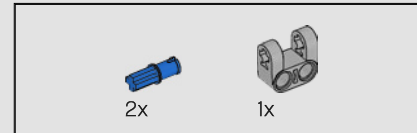
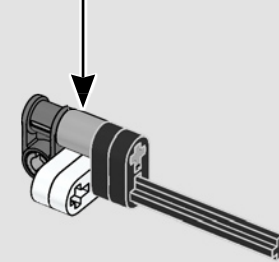
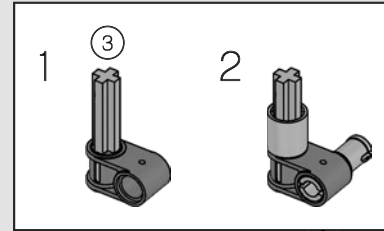

119

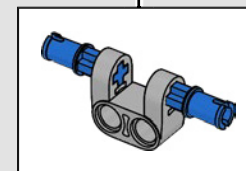
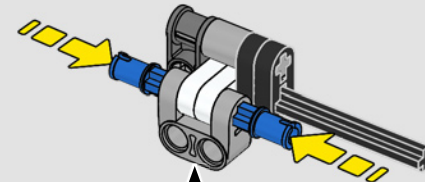



2x

120

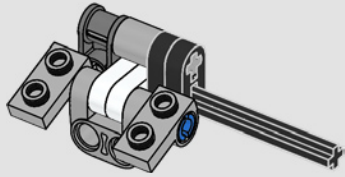

1x



1x

121

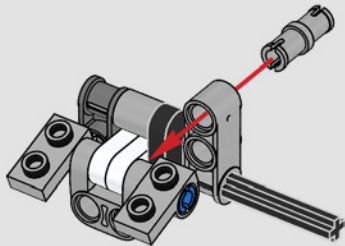

2x

122

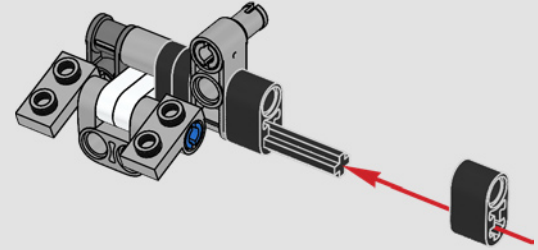

1x



1x

123

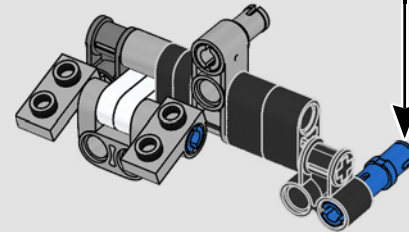
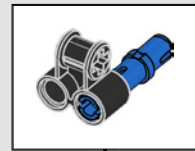

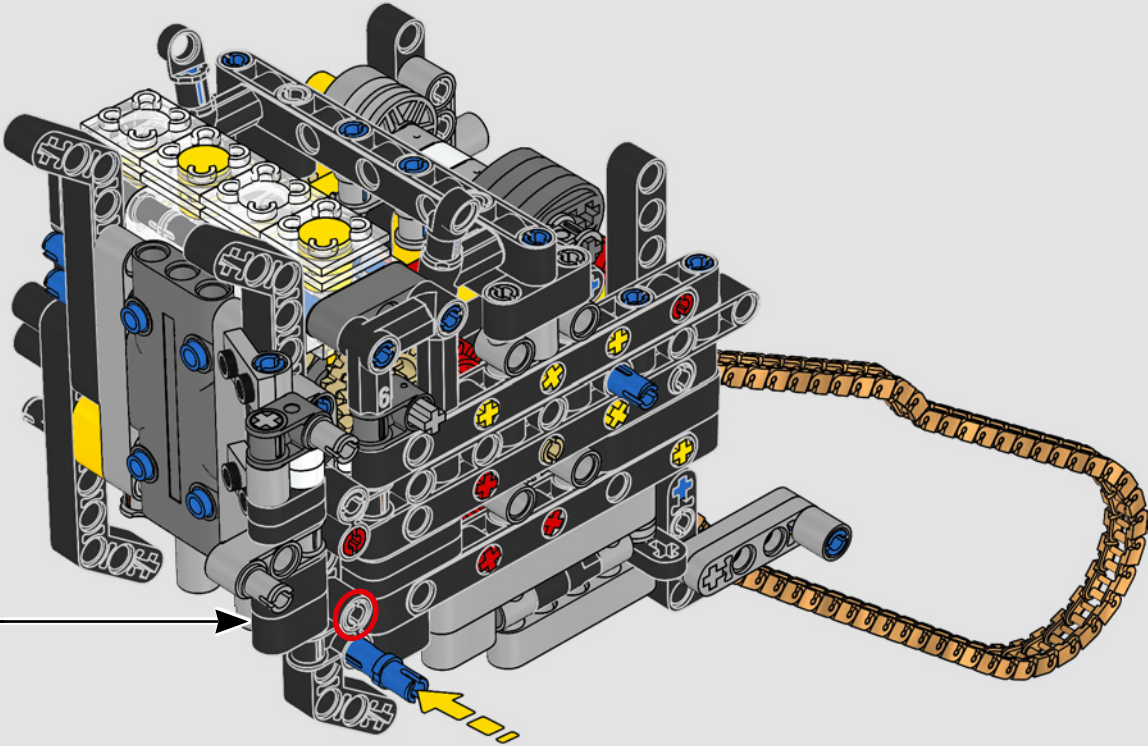

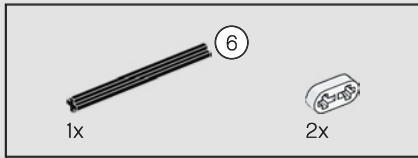
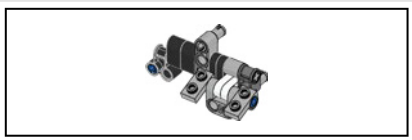

125

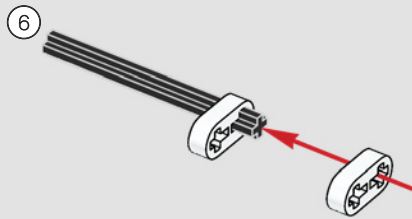

126

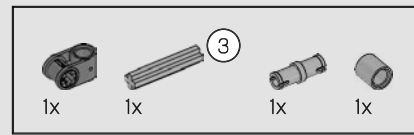
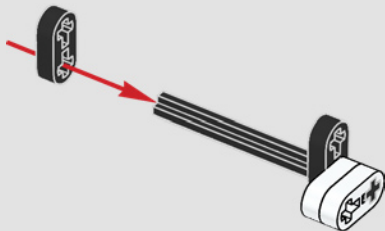

127

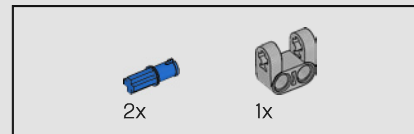
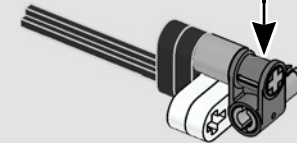
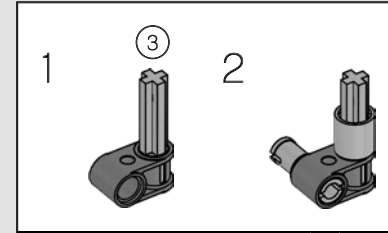

128

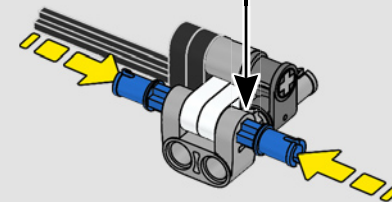
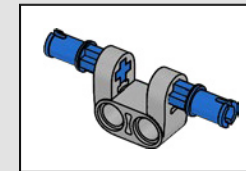

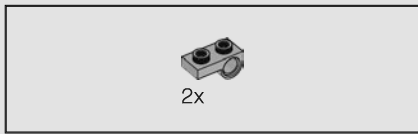

129

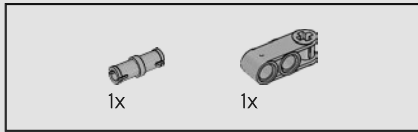
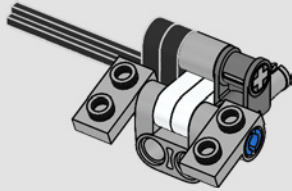

130

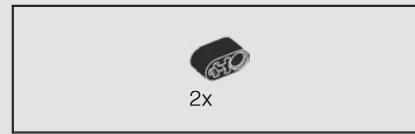
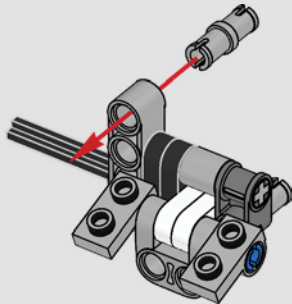

131

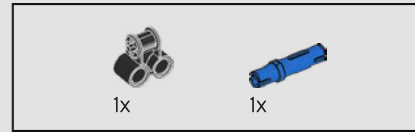
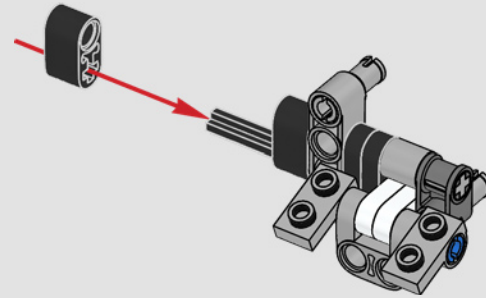

132

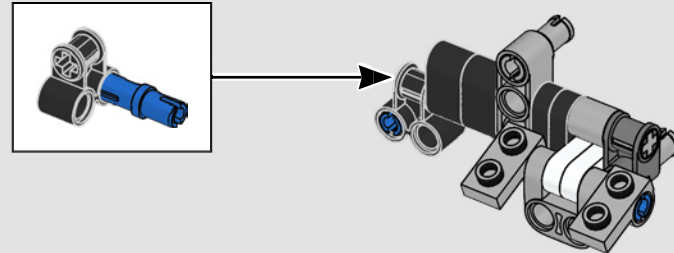

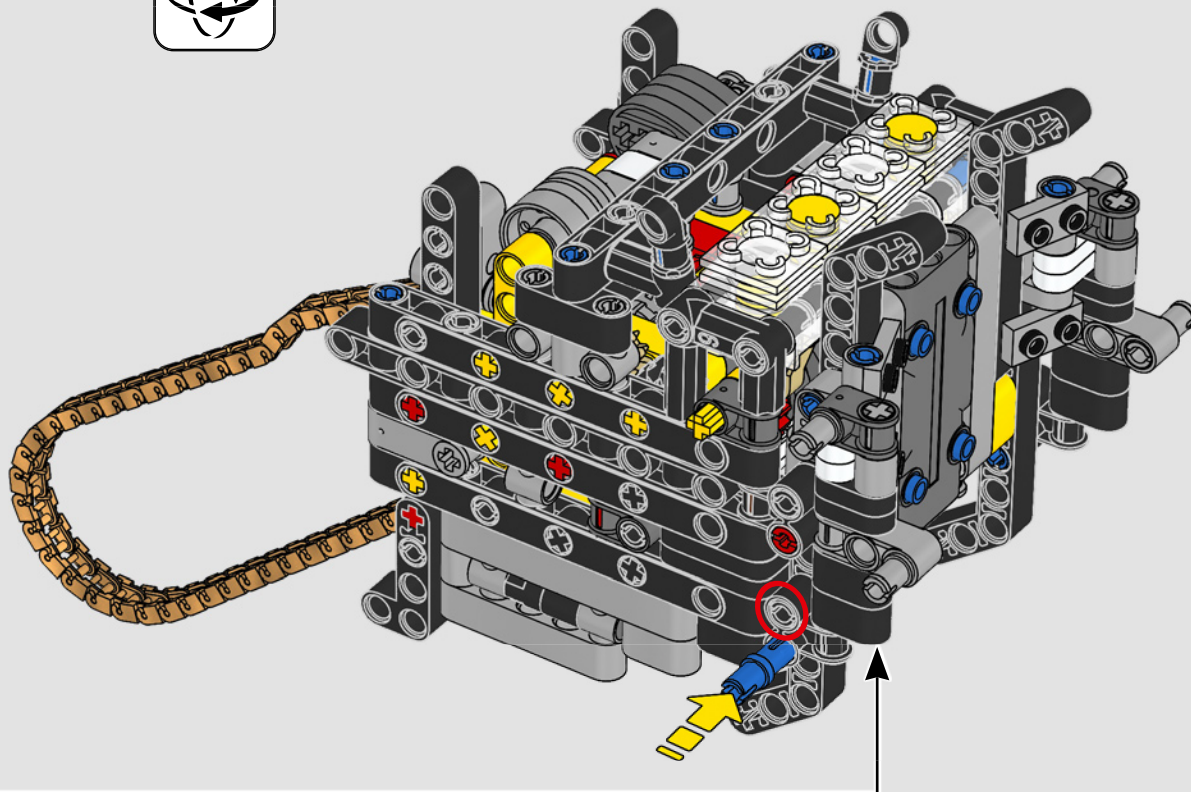

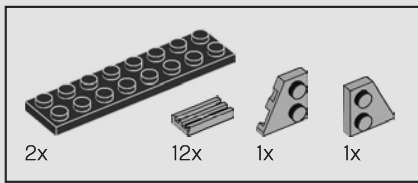

134

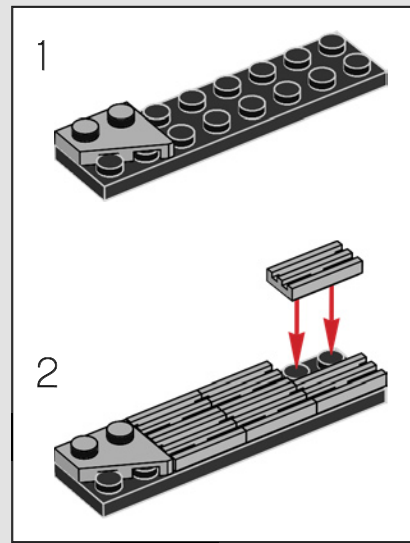
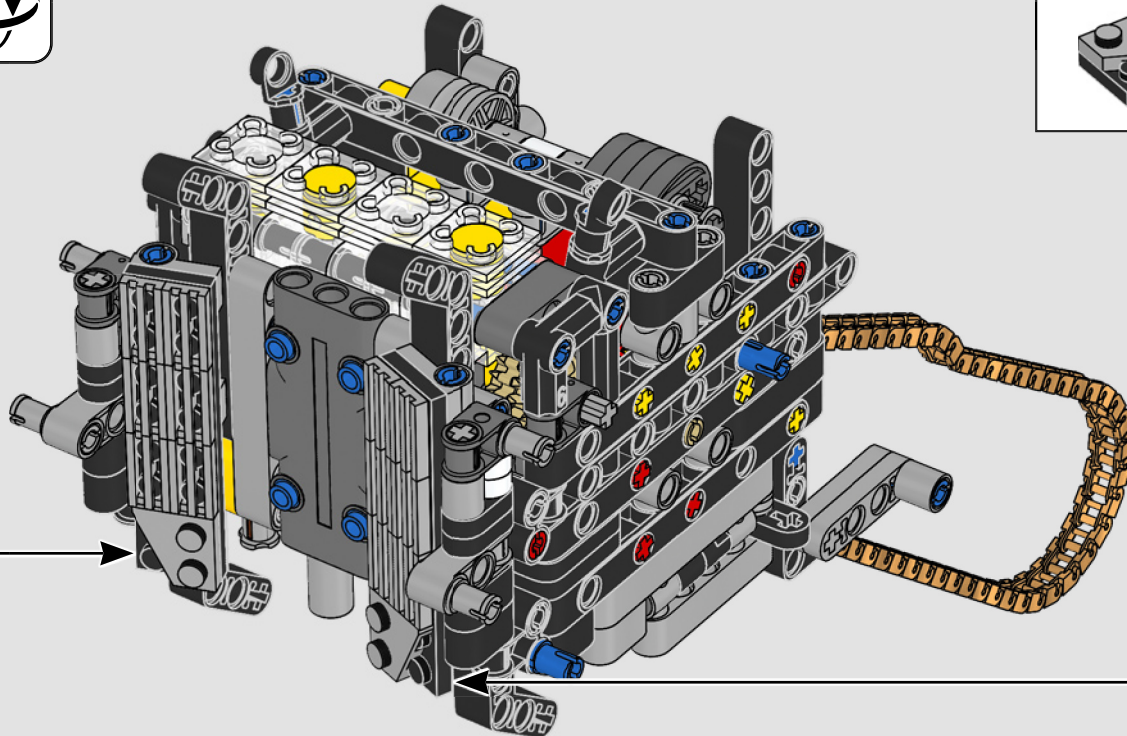
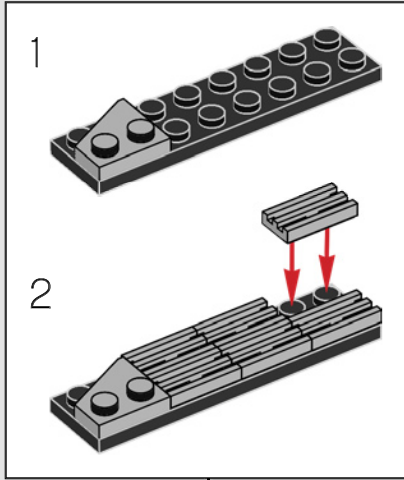

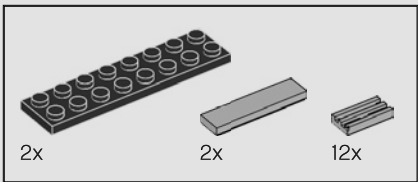

135

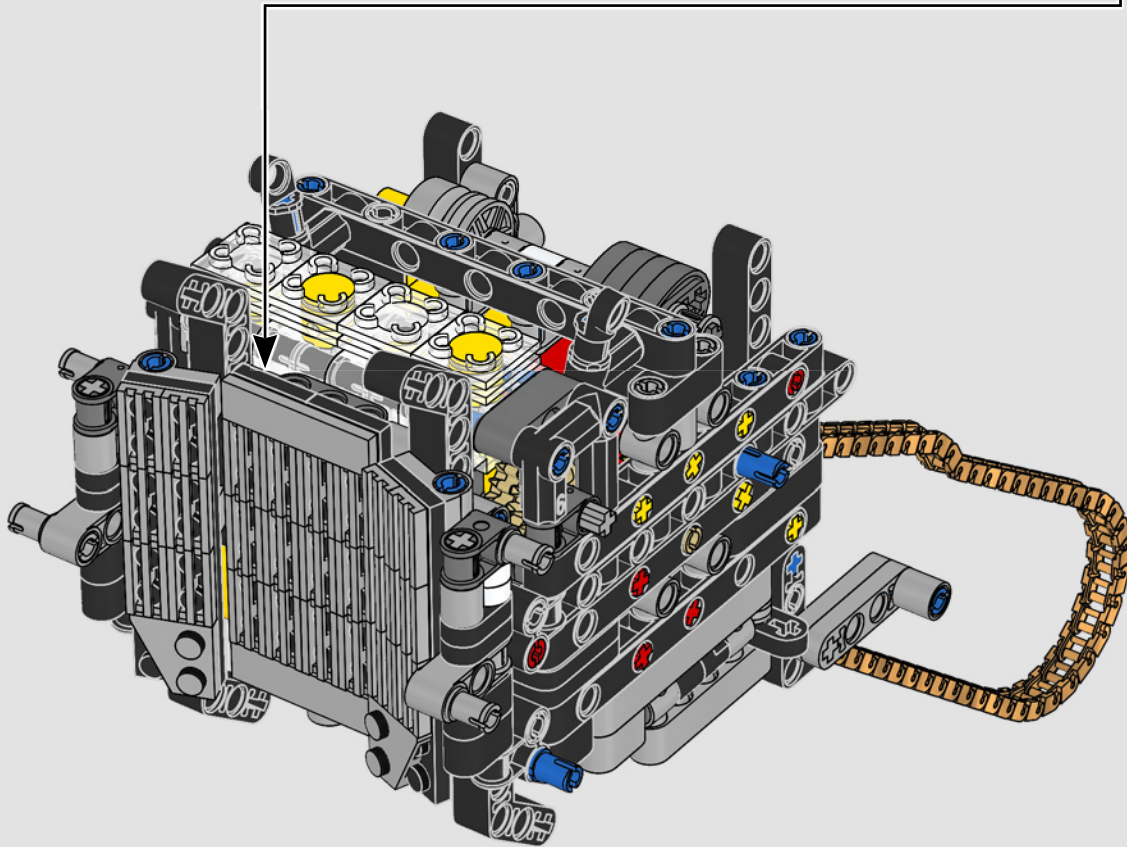
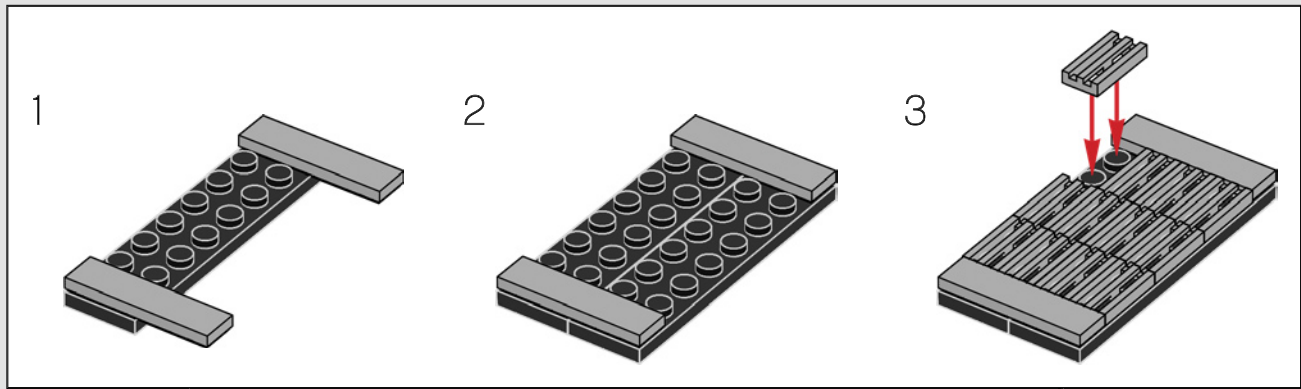

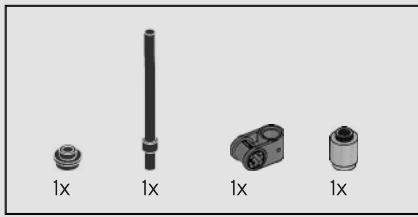

136

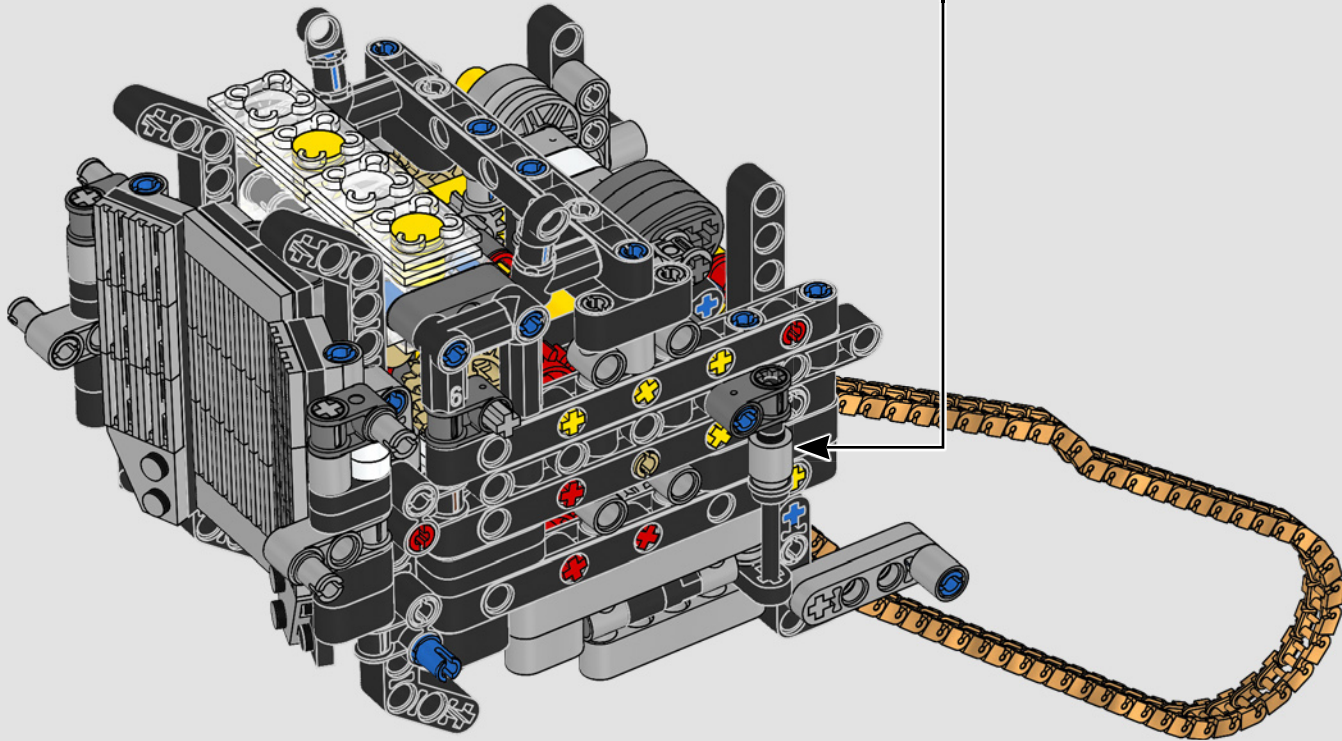
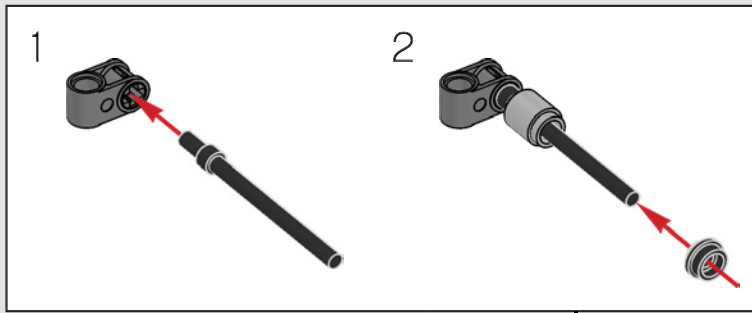

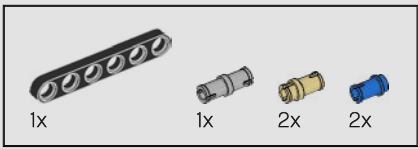

137

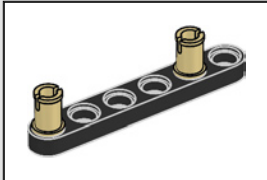
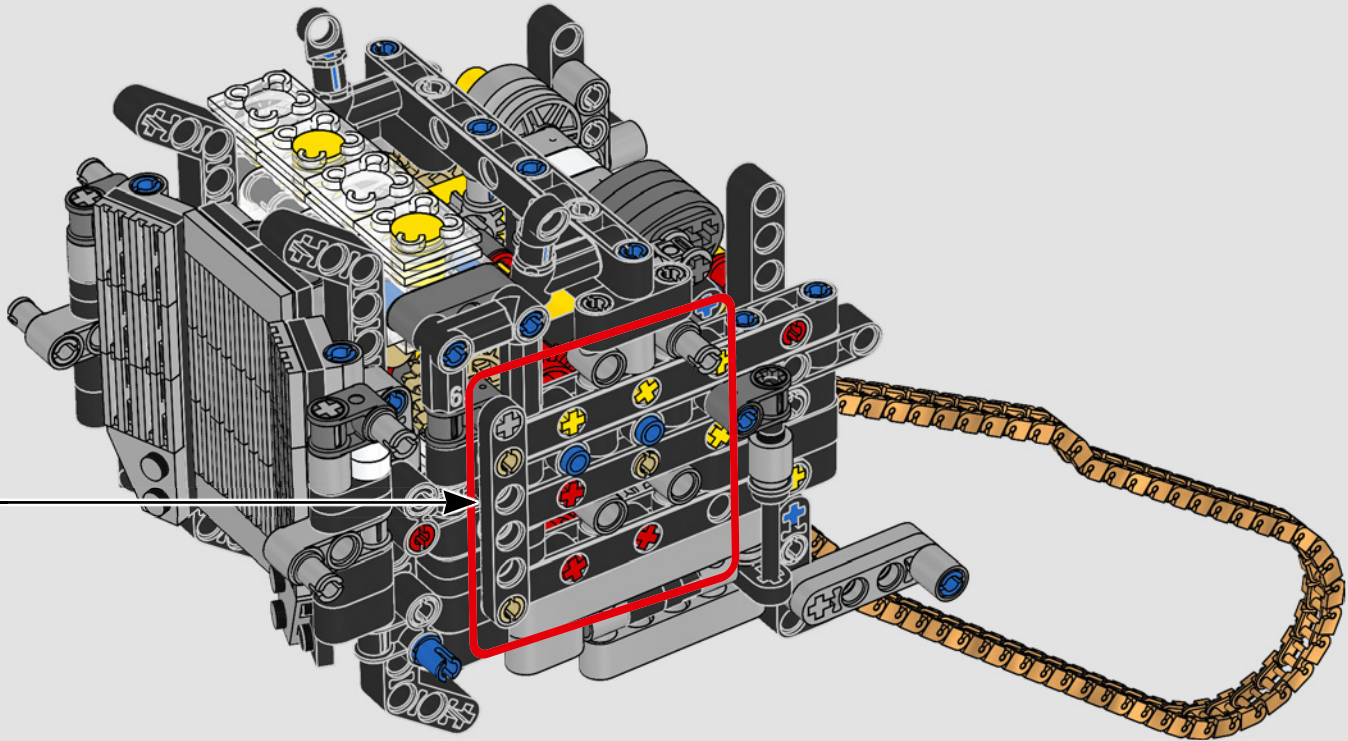

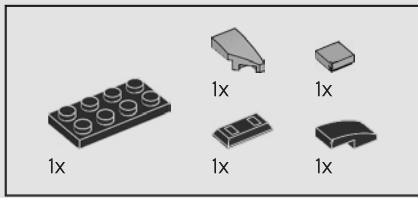

138

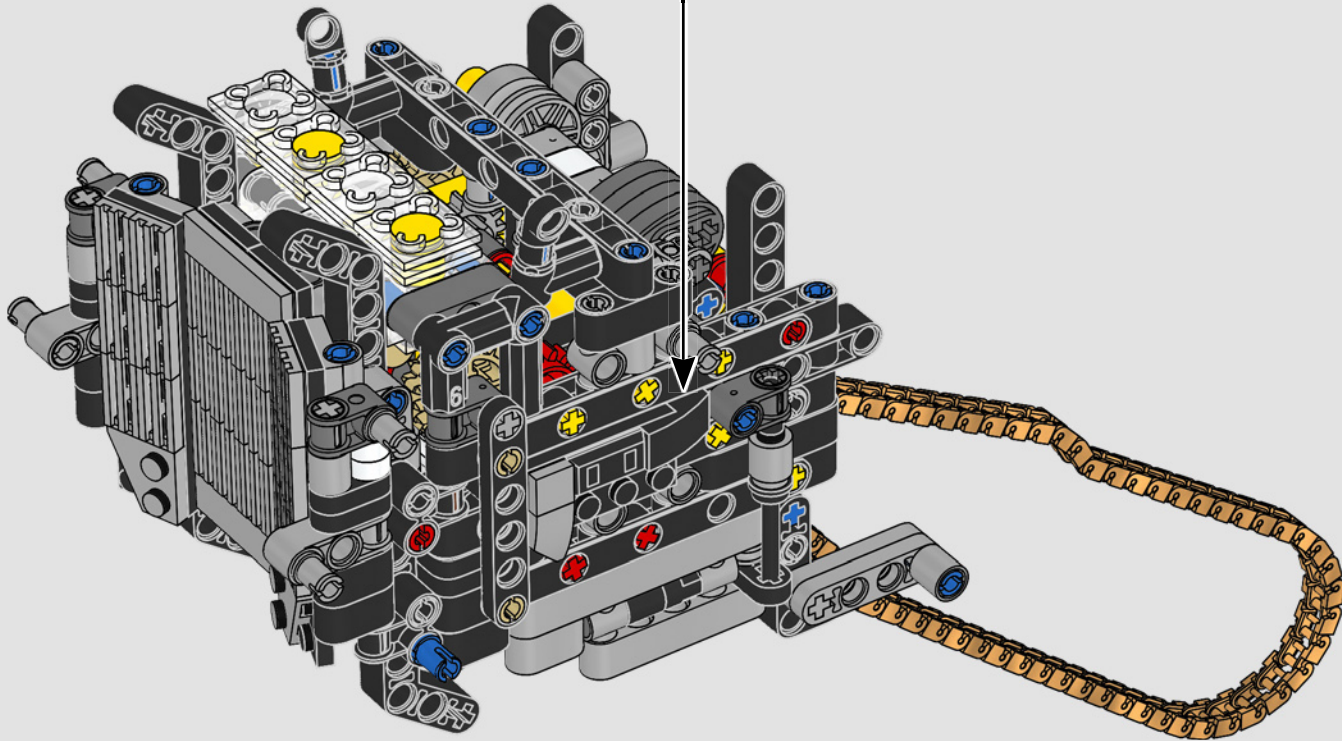
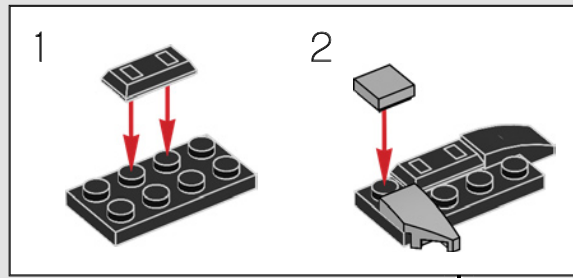

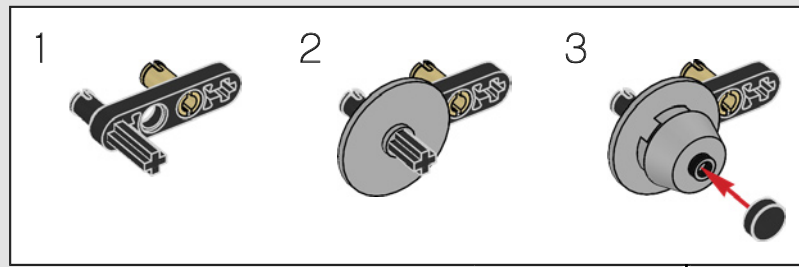
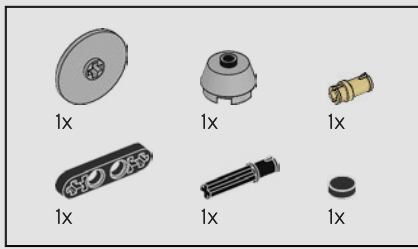

139

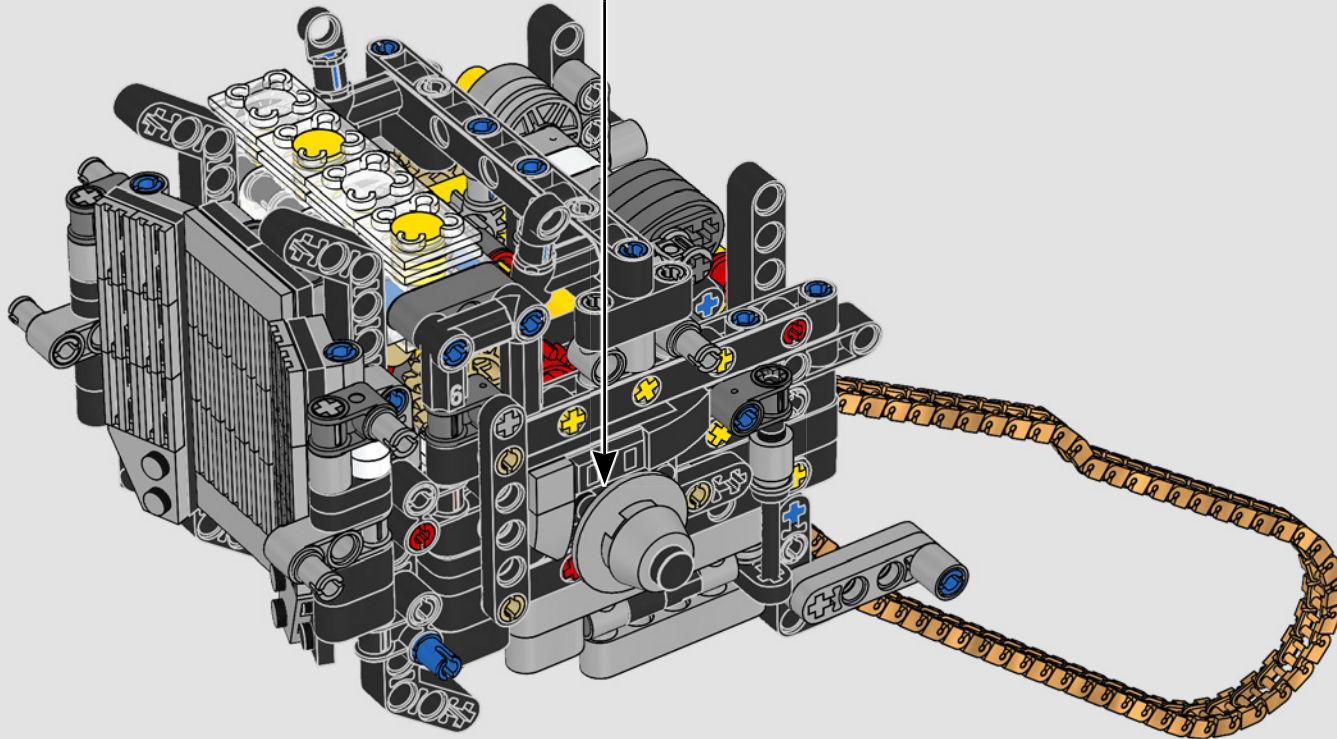

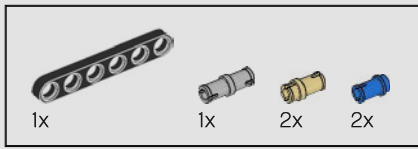

140

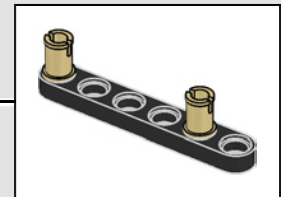
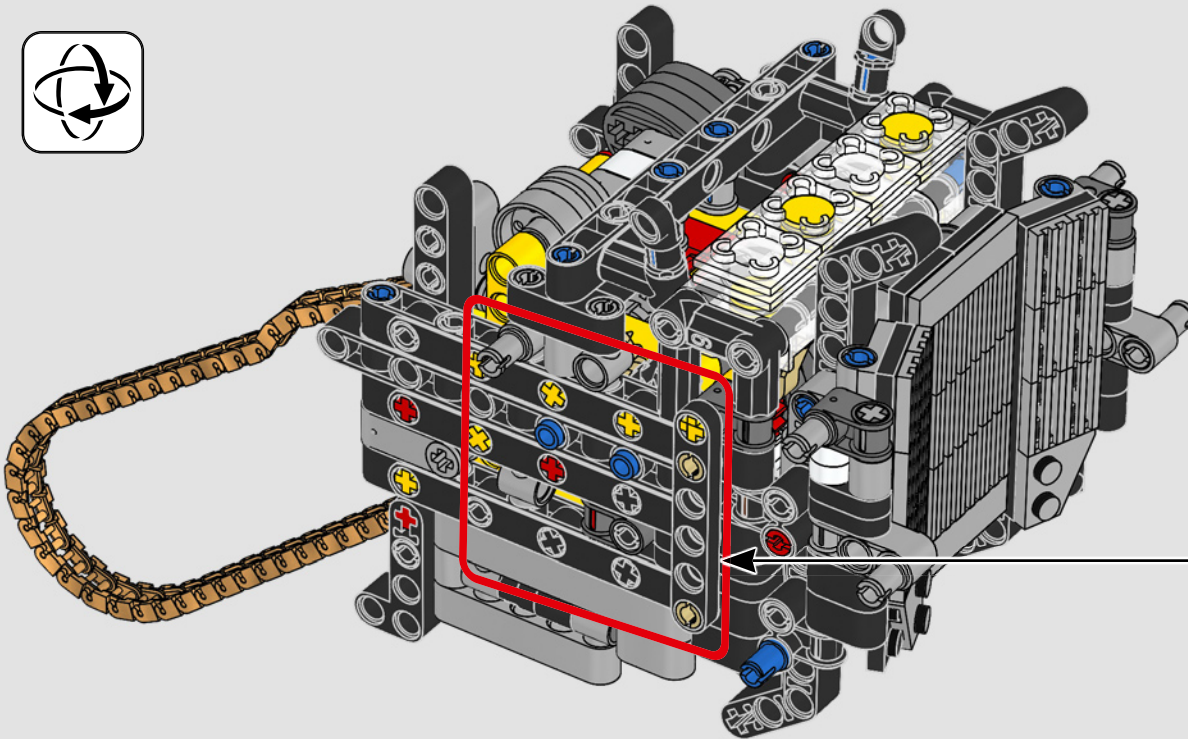

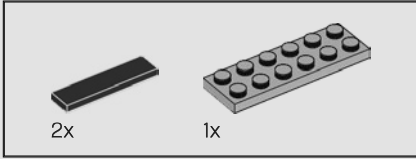
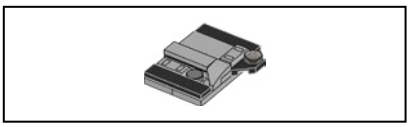

141

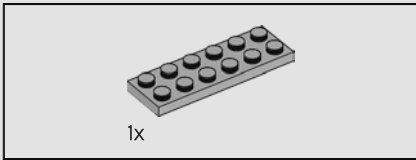
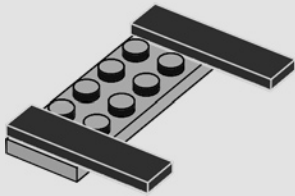

142

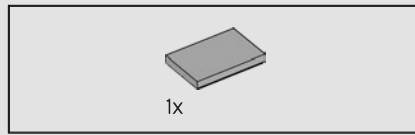
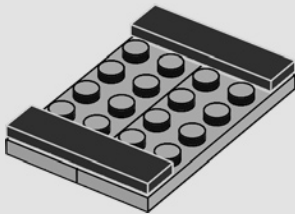

143

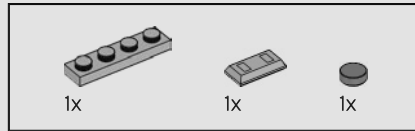
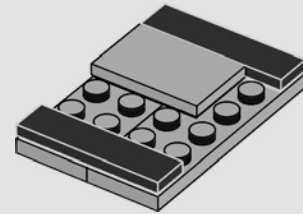

144

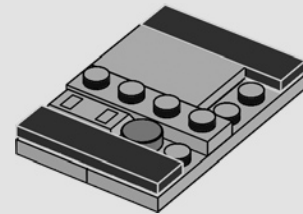

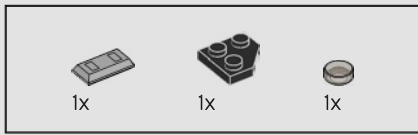

145

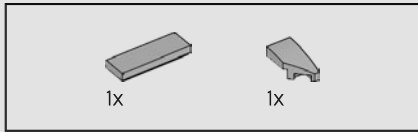
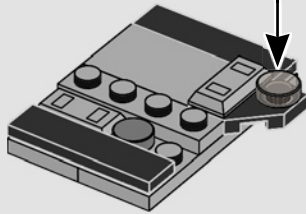
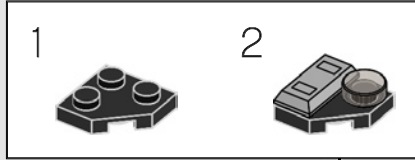

146

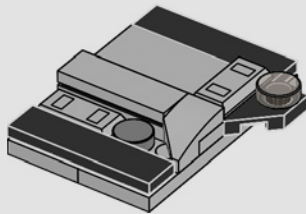

147

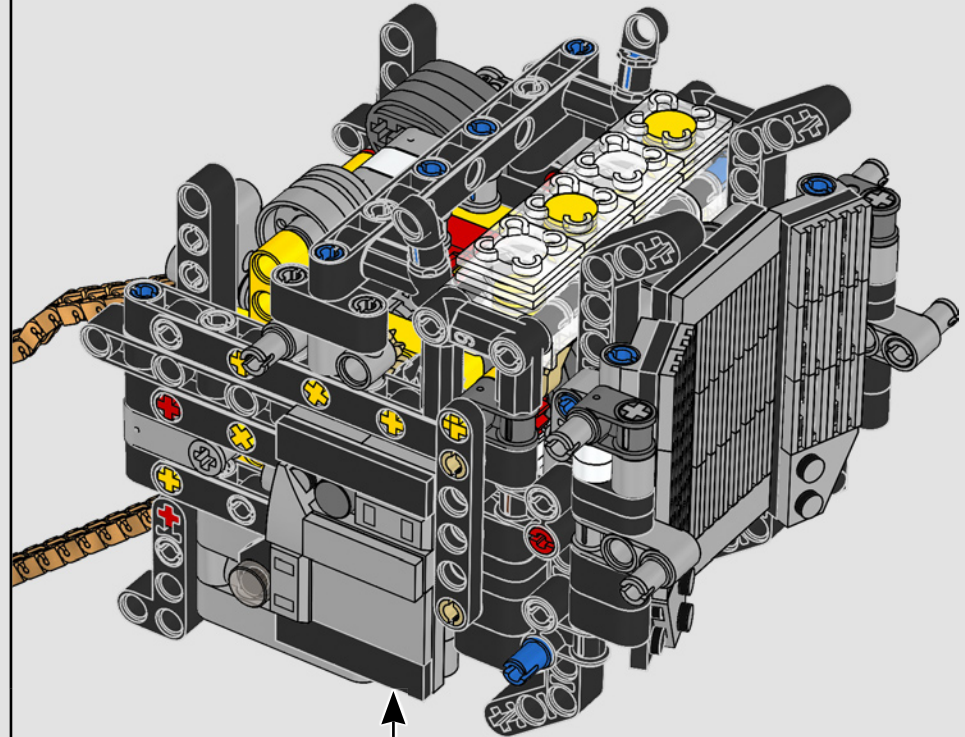

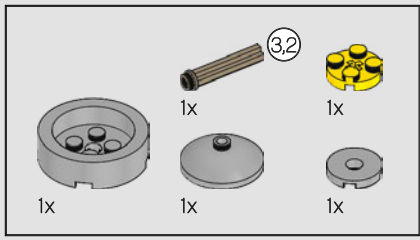

148

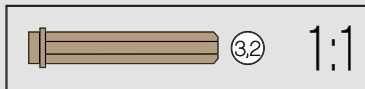
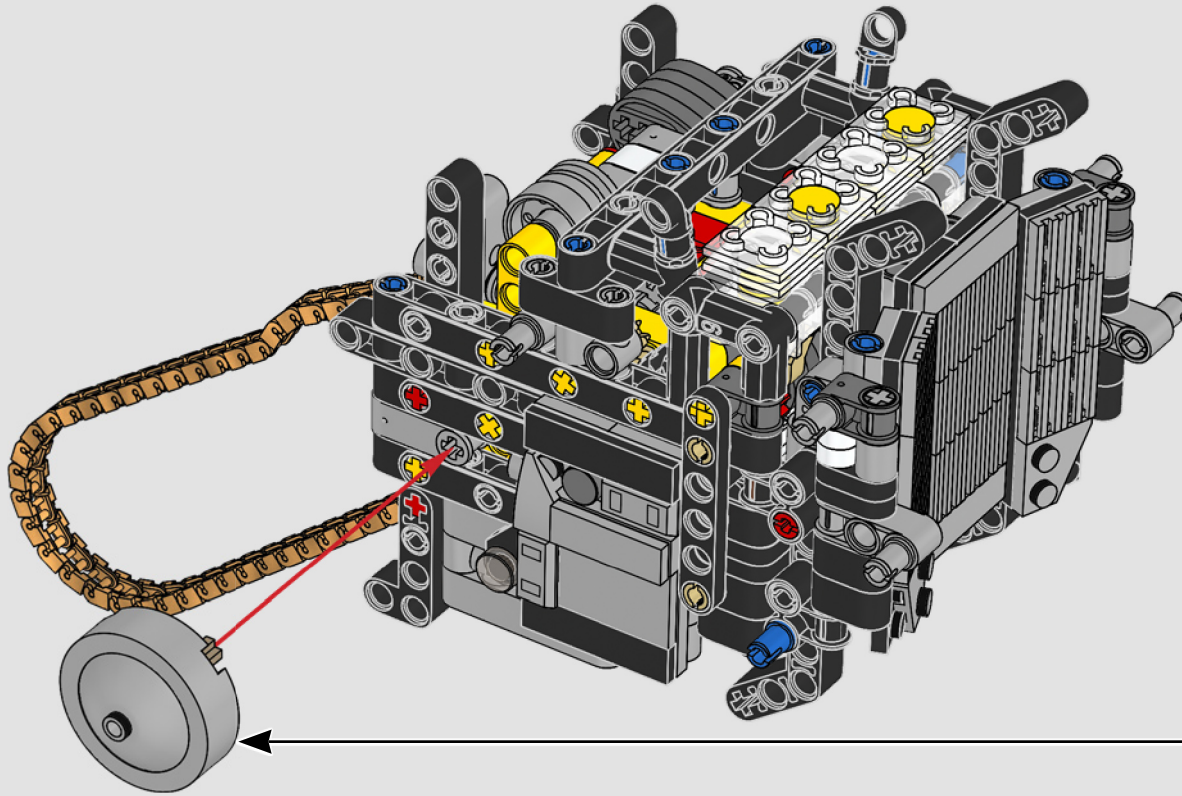
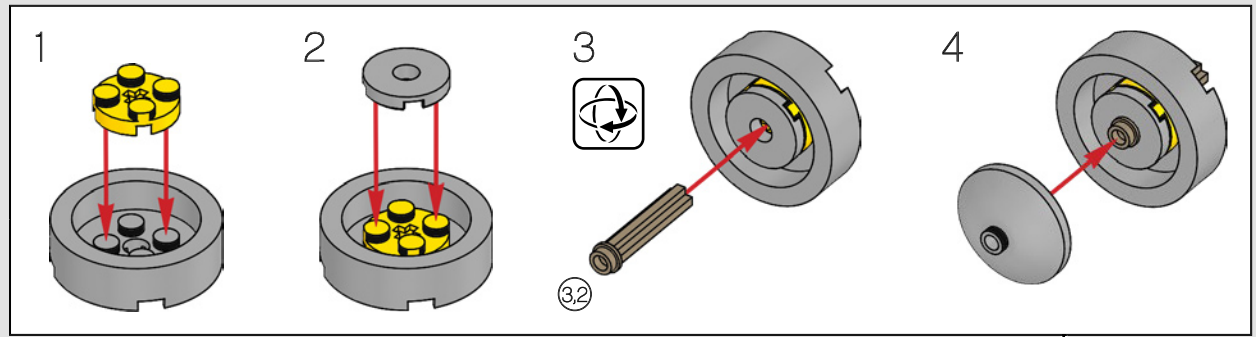

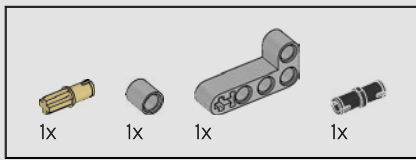

149

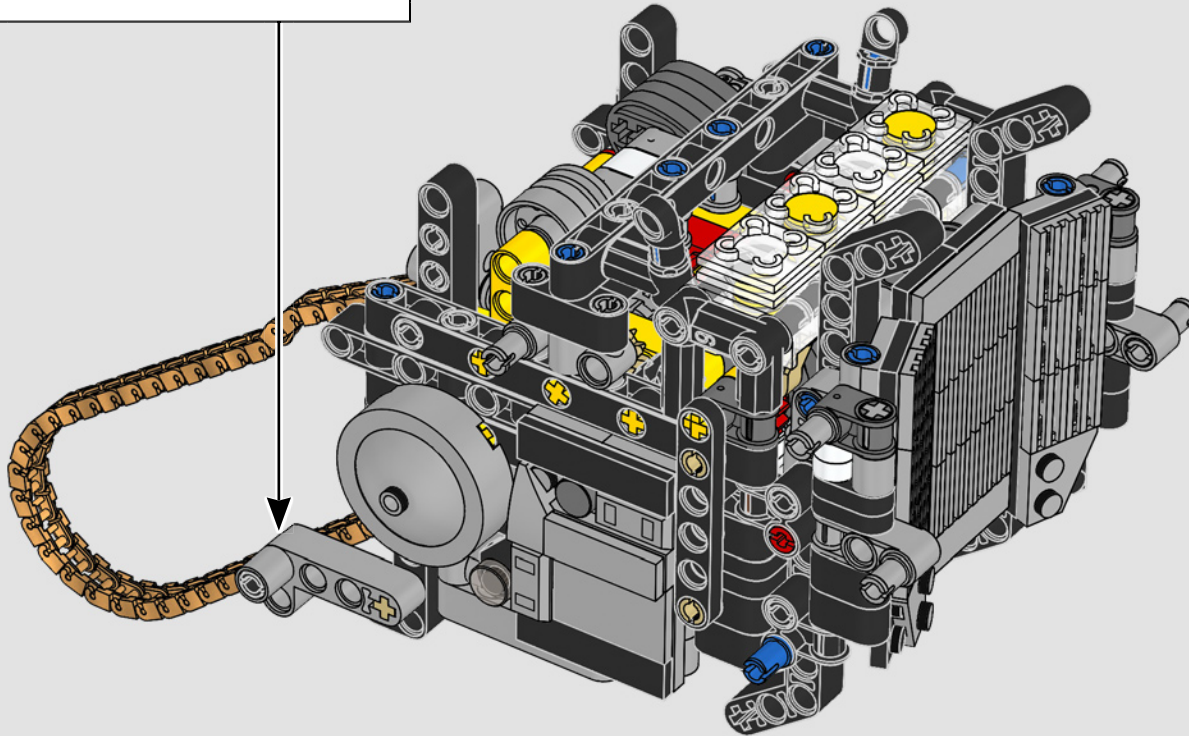
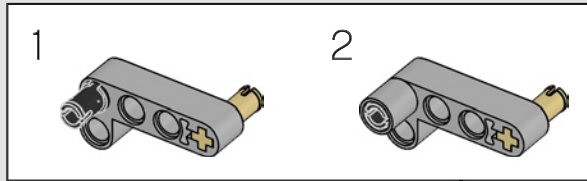

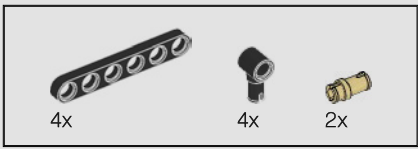

150

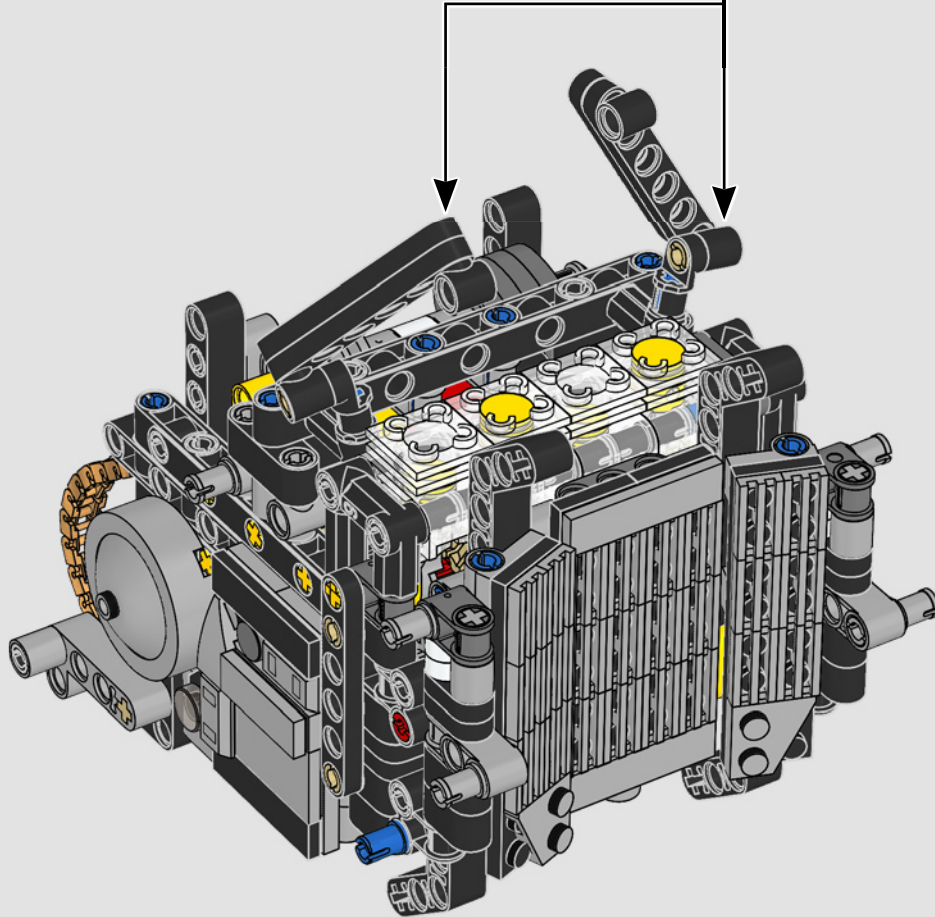
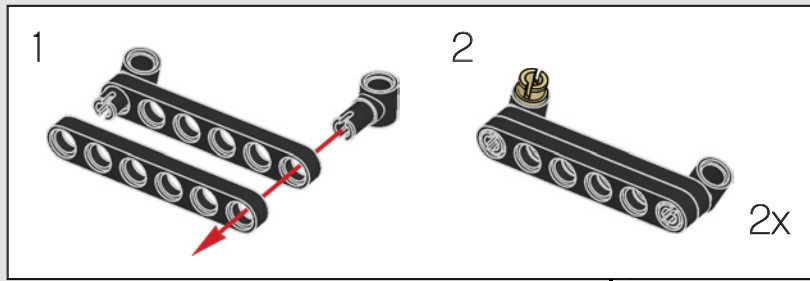

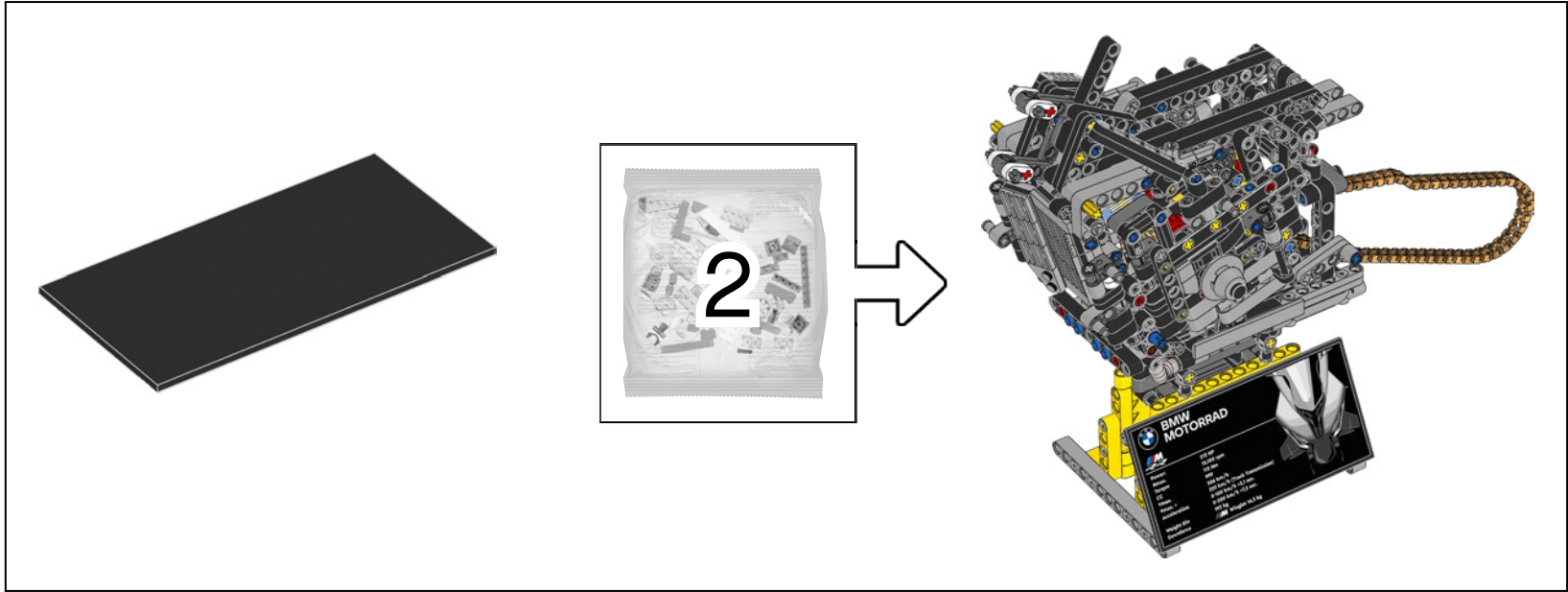

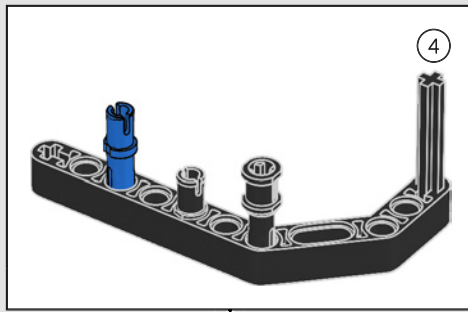
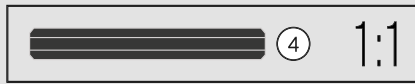
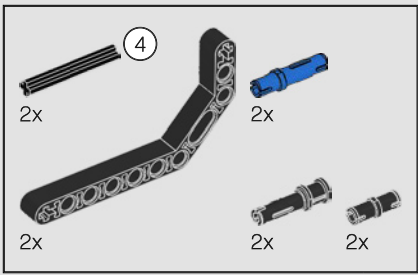

151

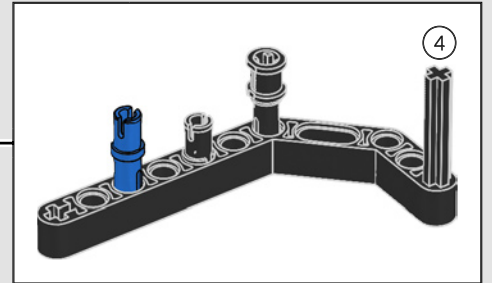
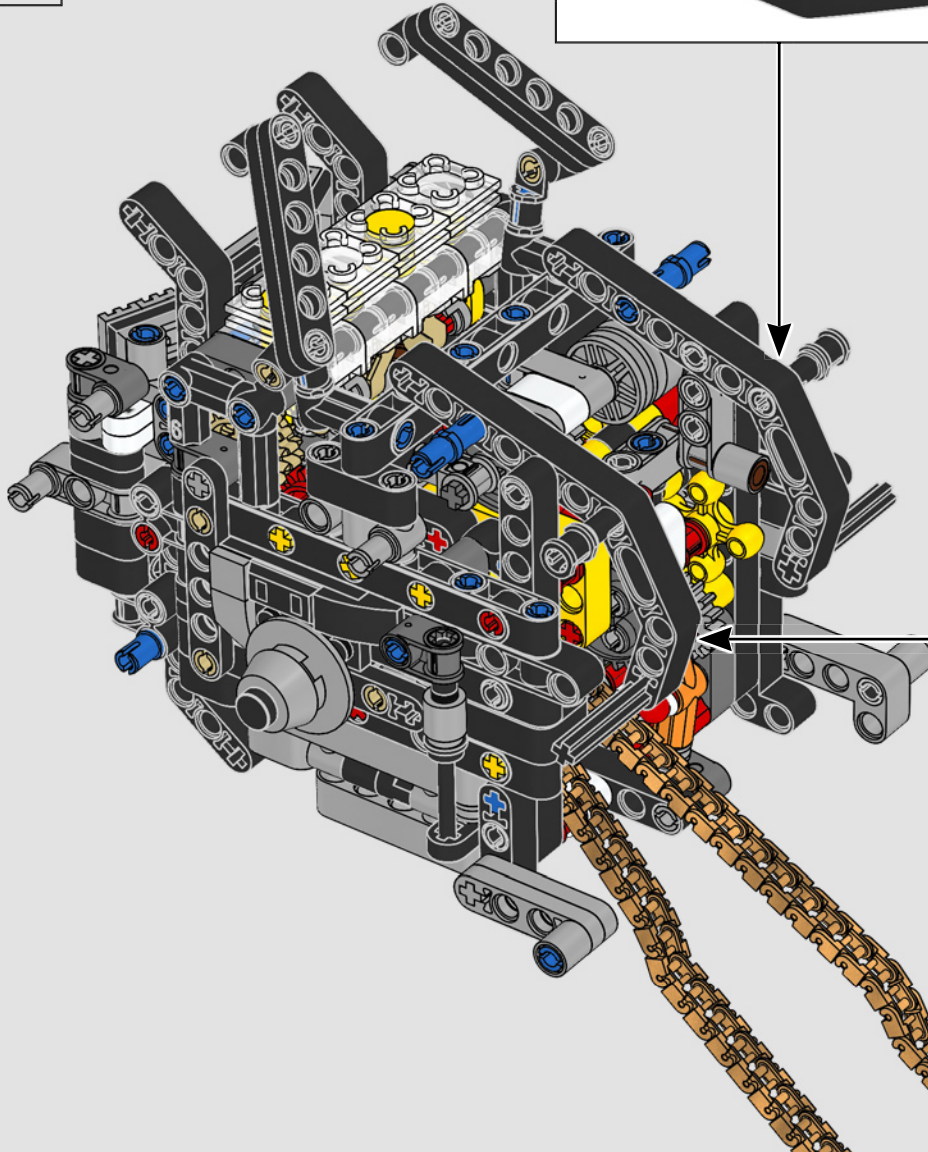

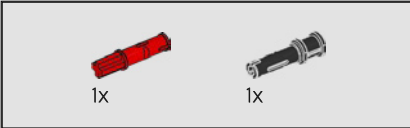
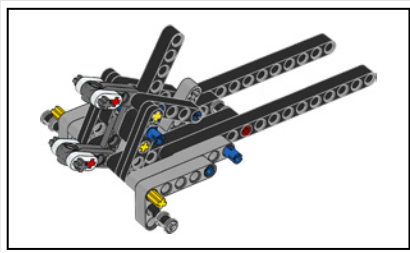

152

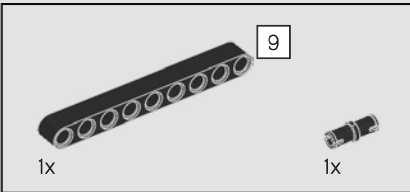
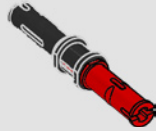

153

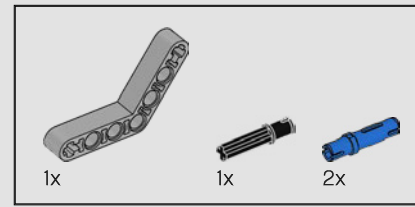
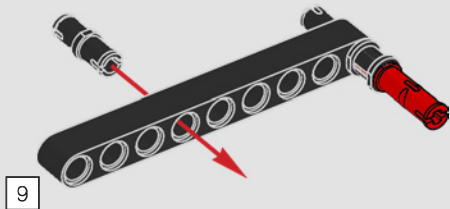

154

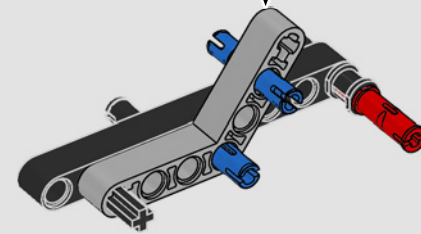
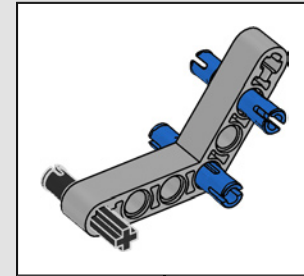

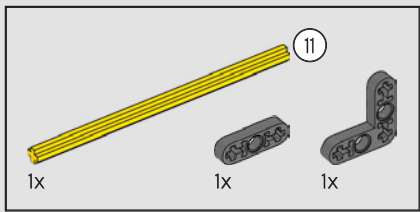

155

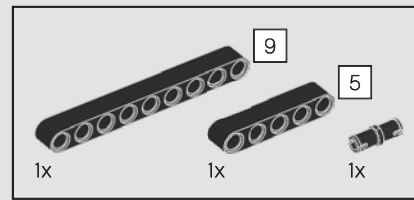
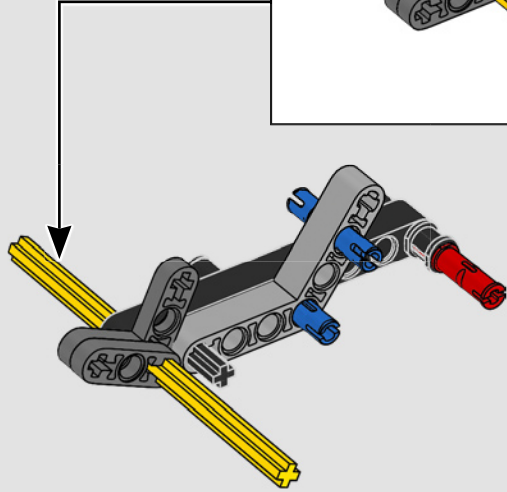
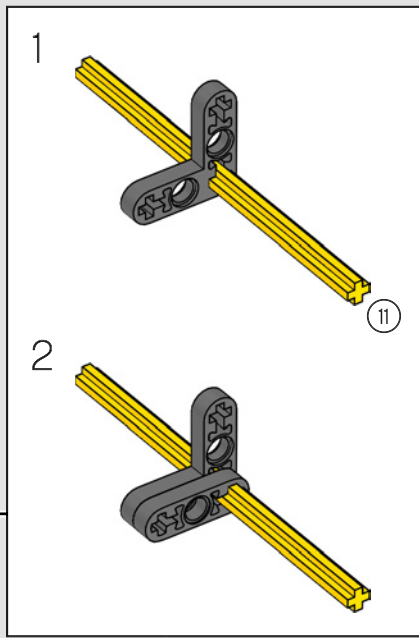

156

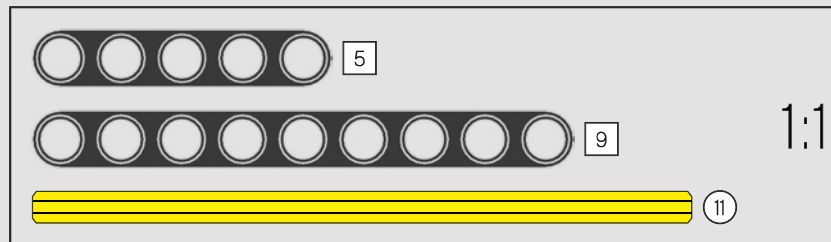
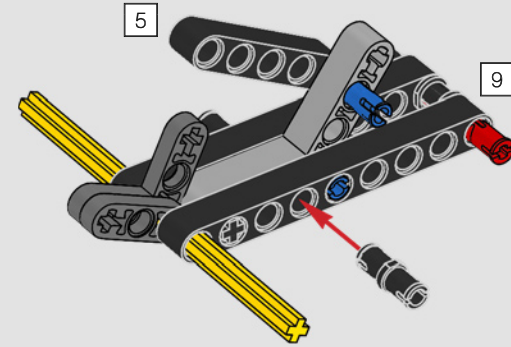

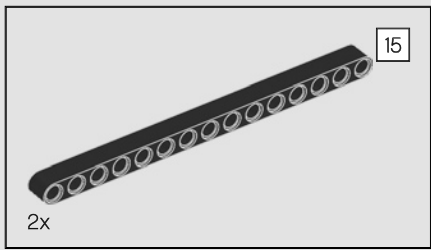

157

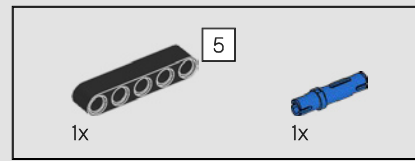
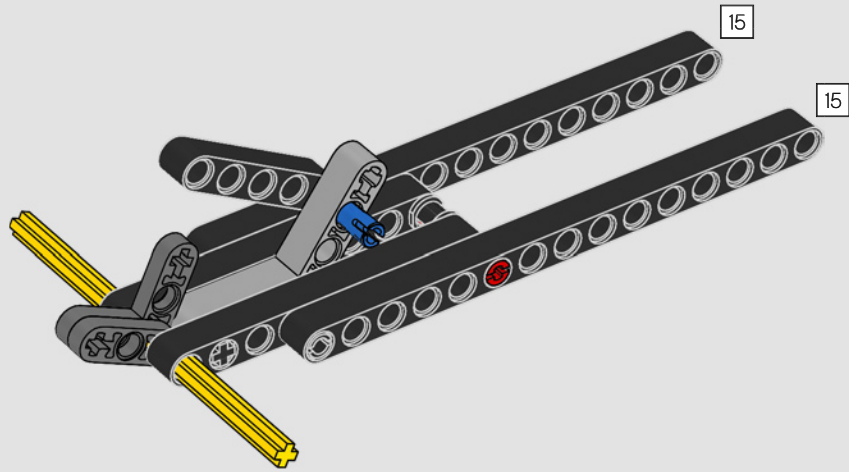

158

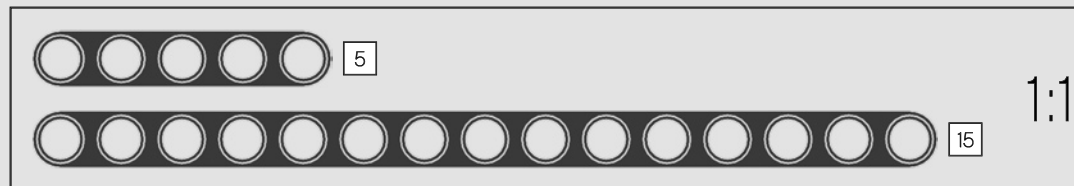
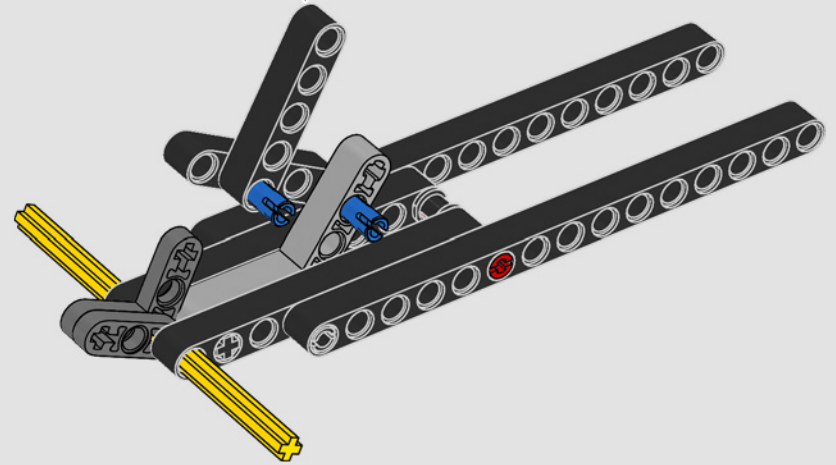
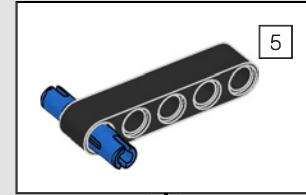

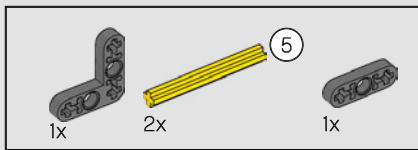

159

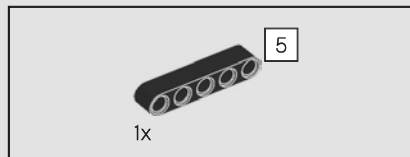
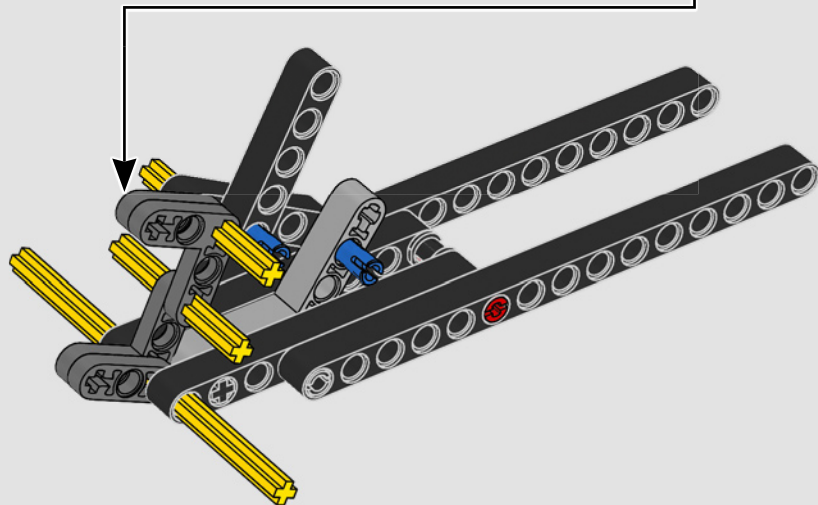
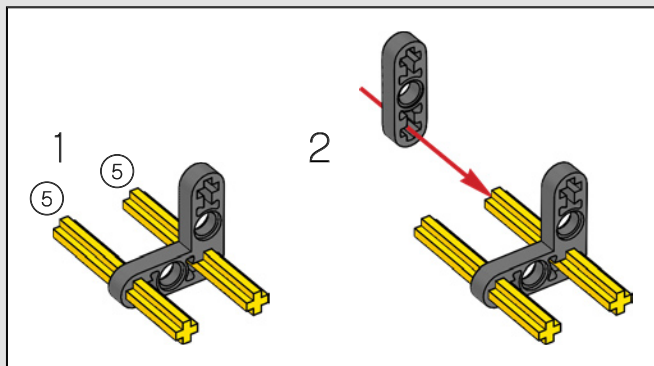

160

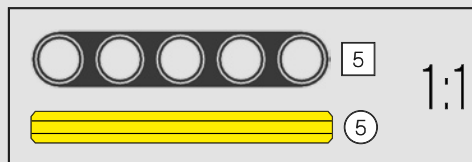
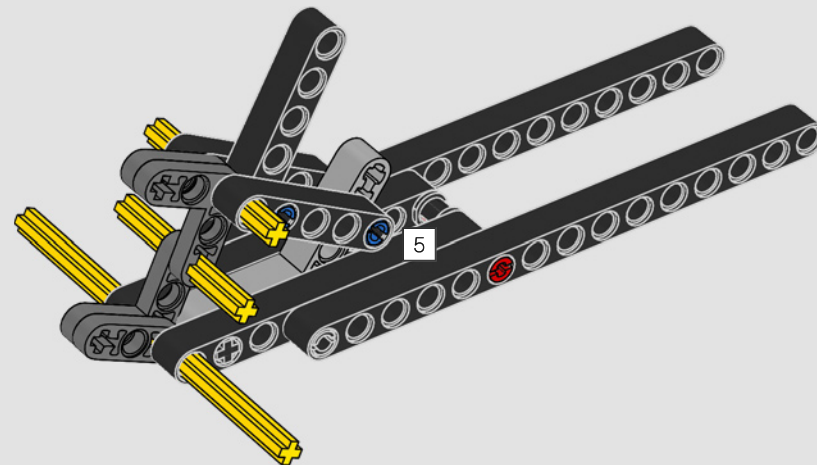



161

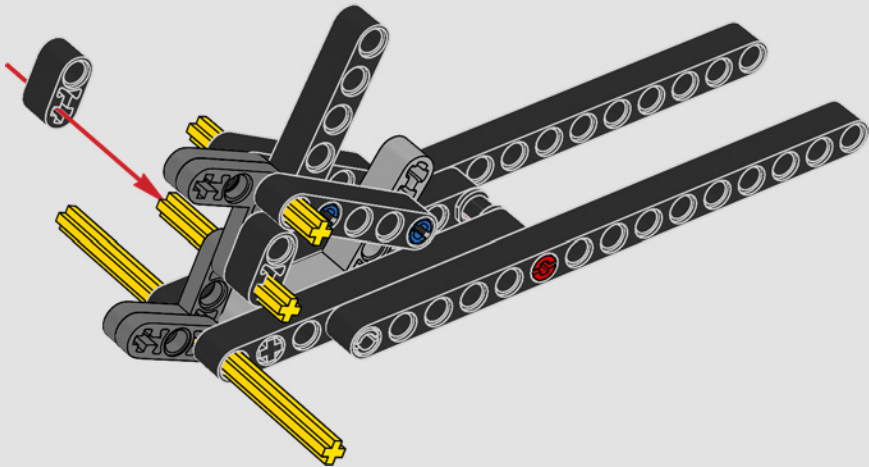

162

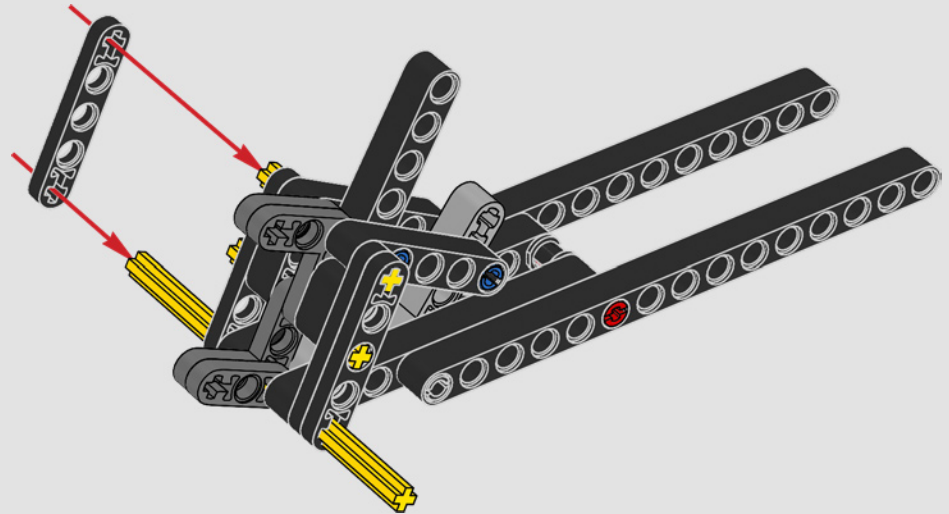

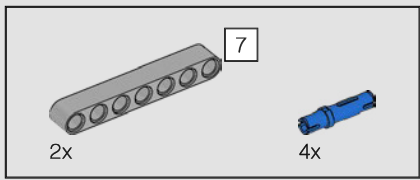

163

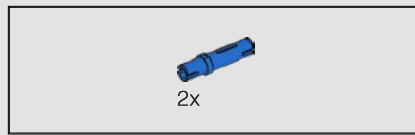
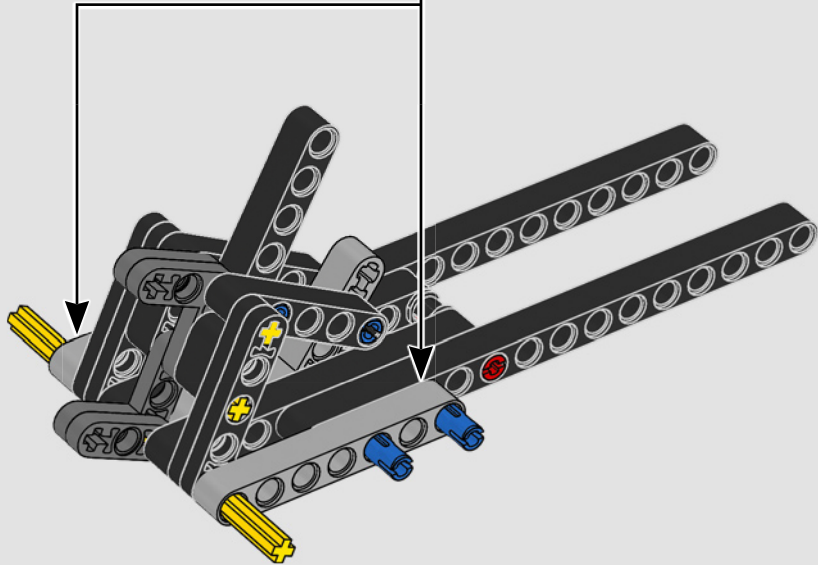
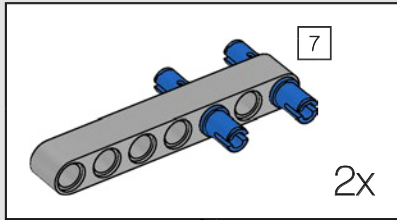

164

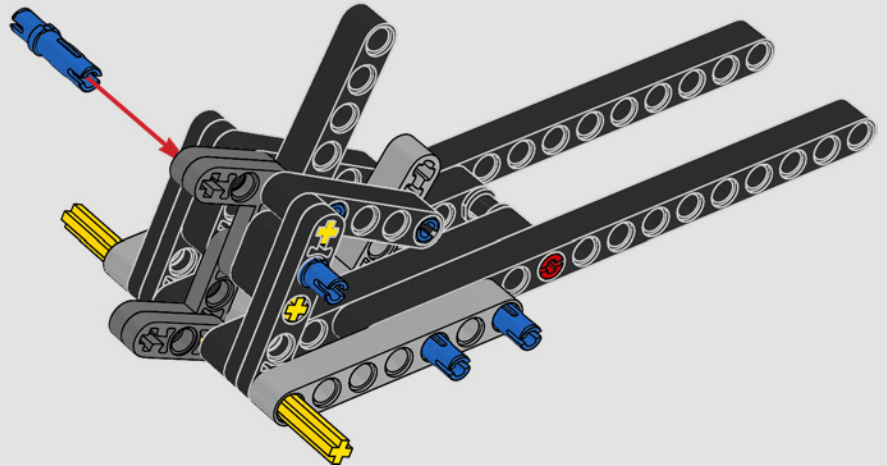

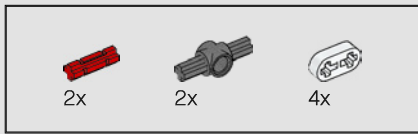

165

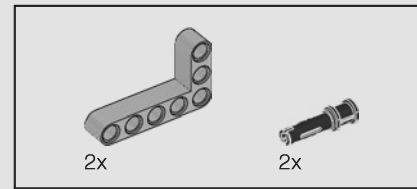
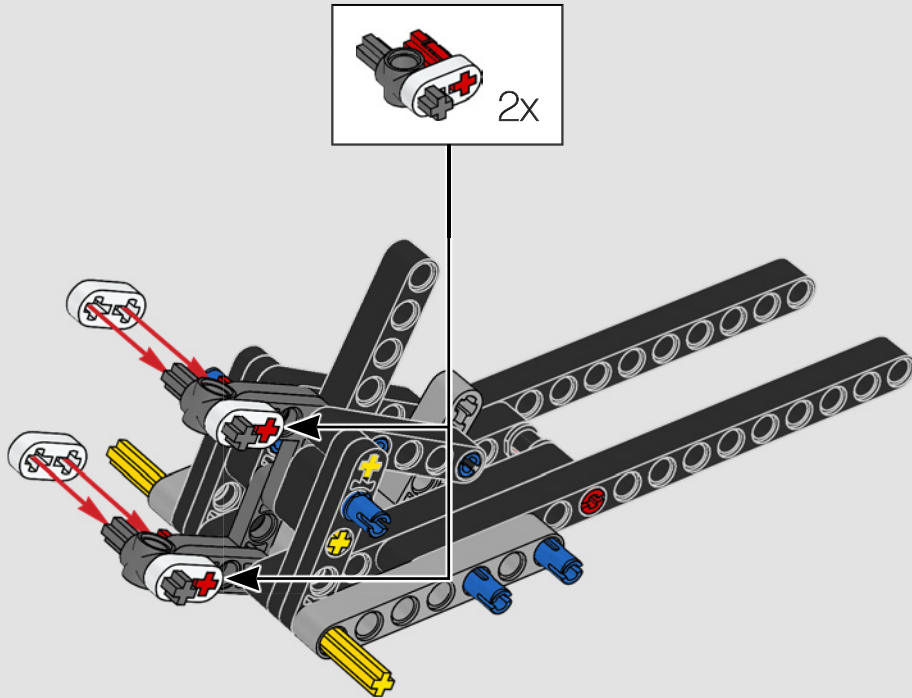

166

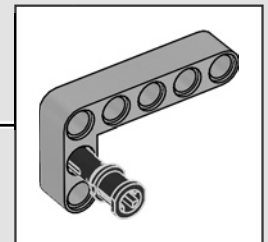
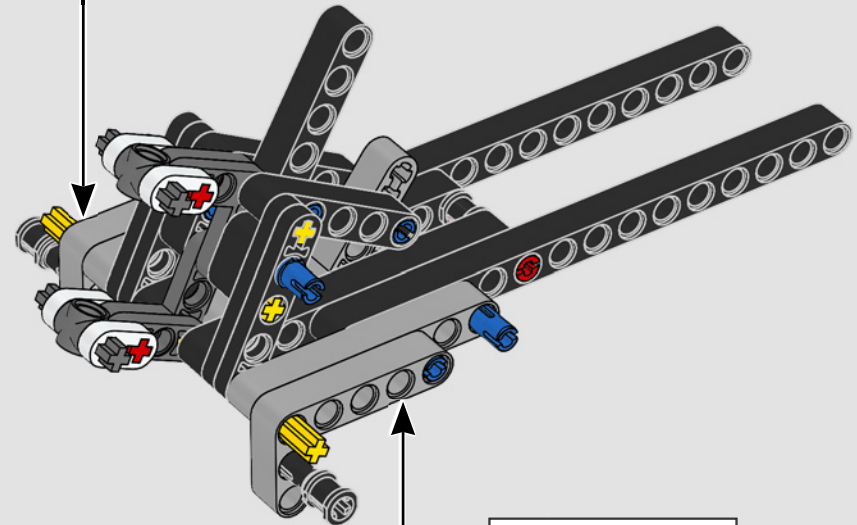
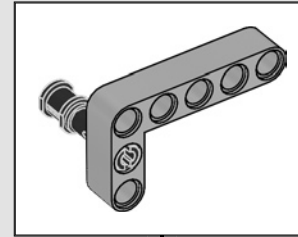

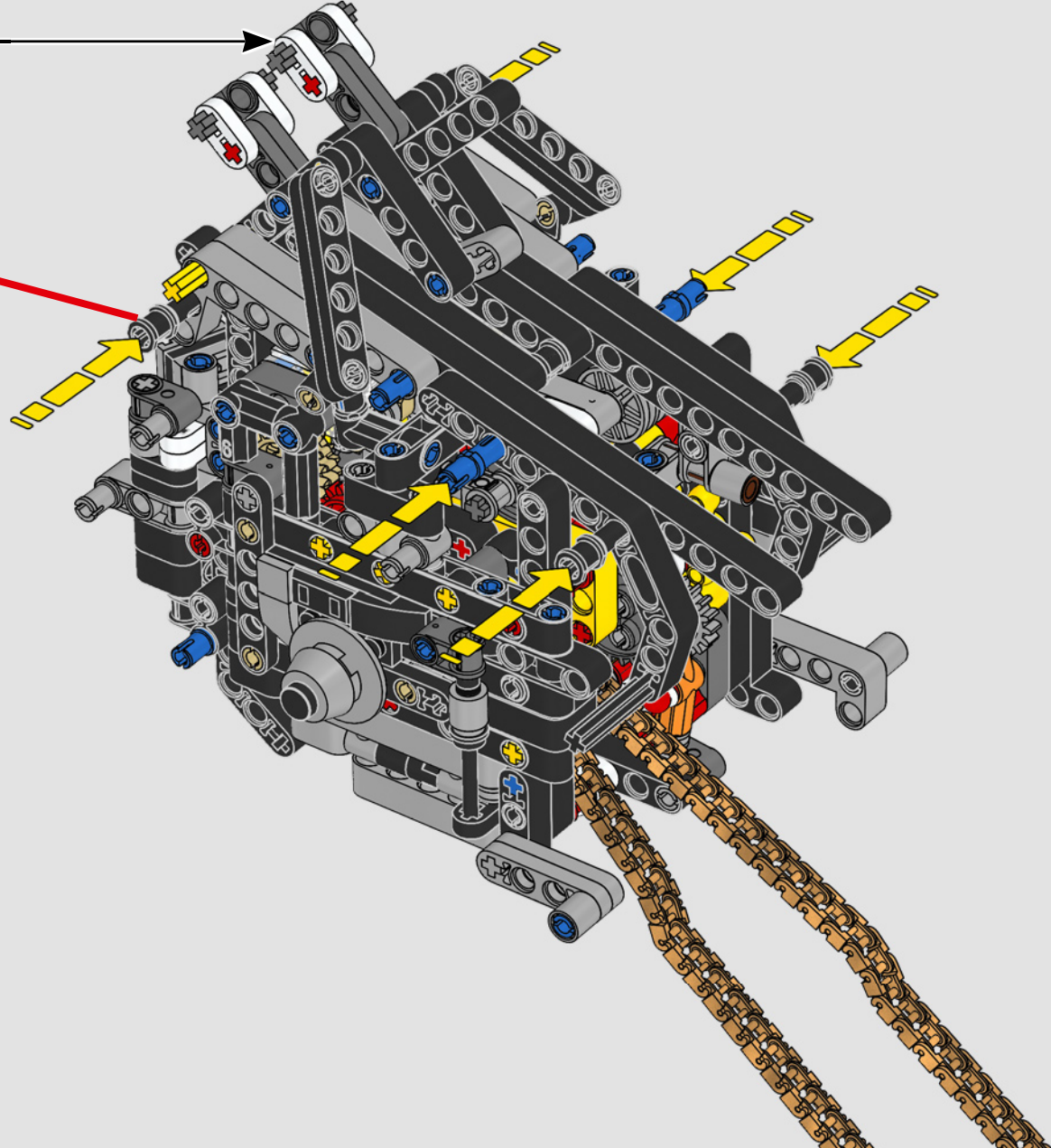
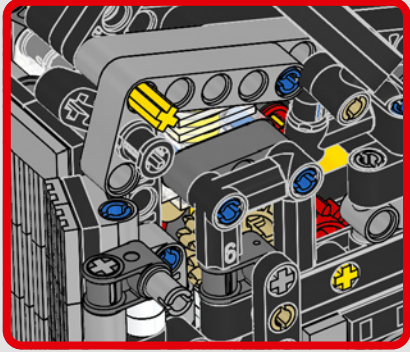

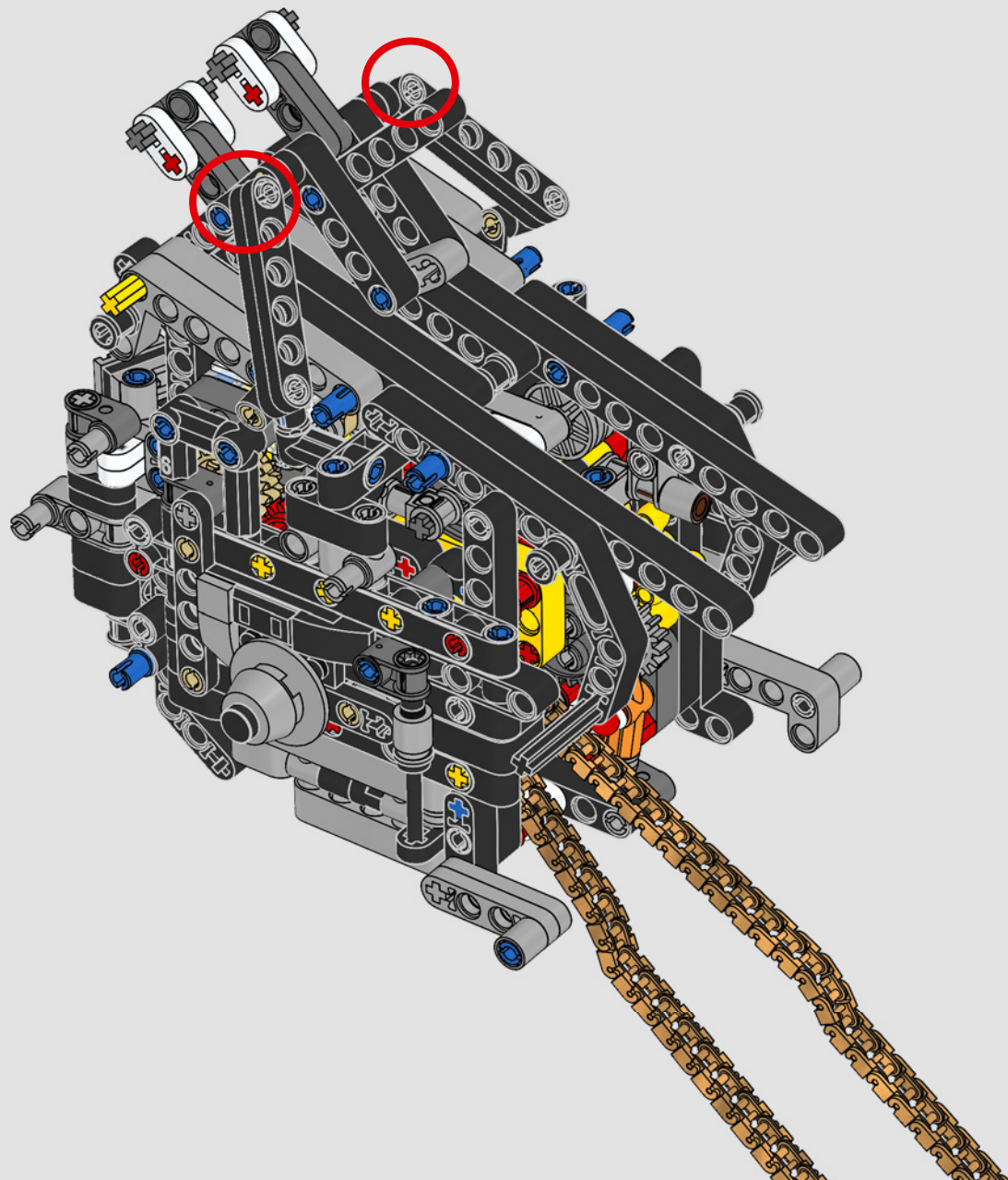

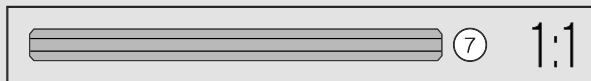
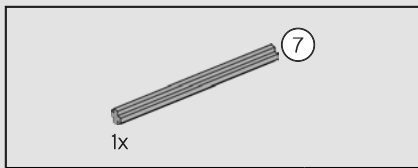

169

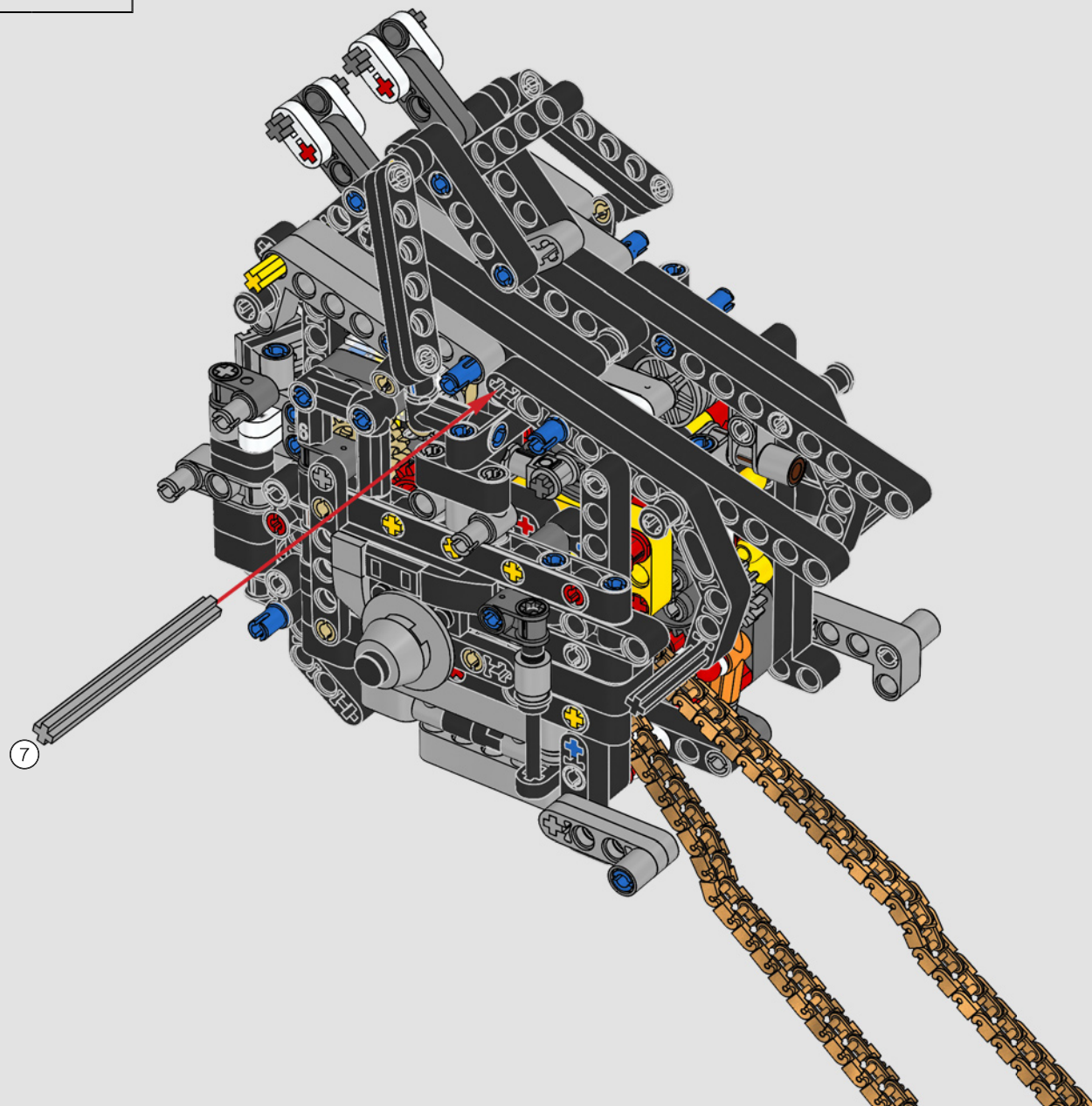



170

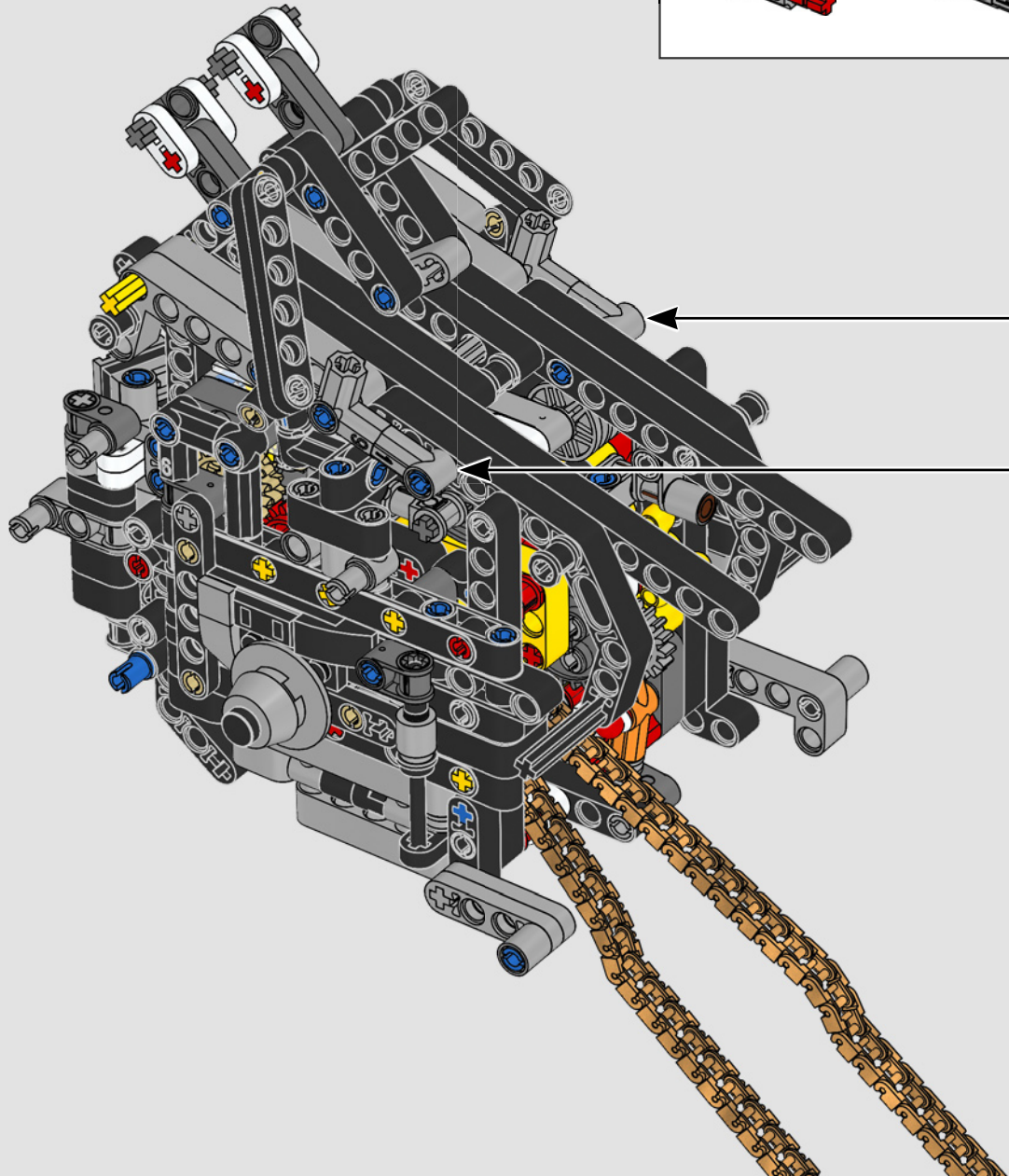
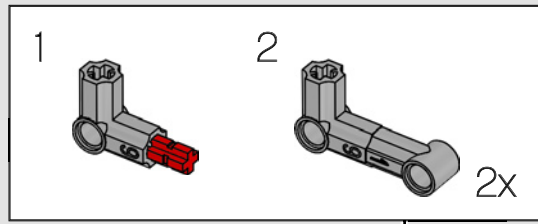

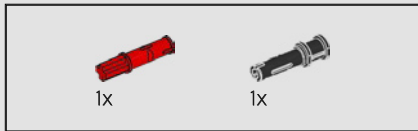
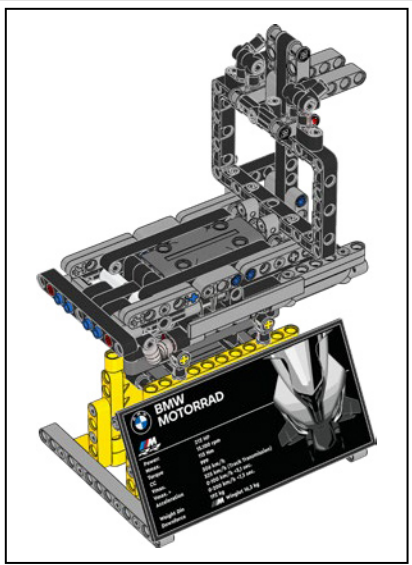

171

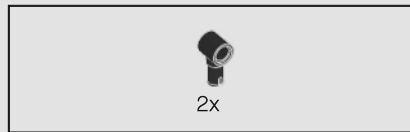

172

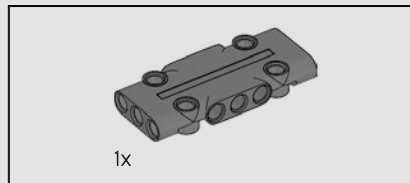

173

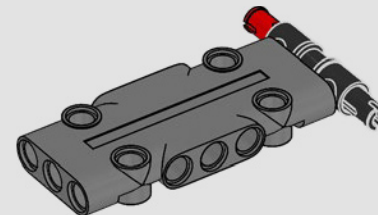

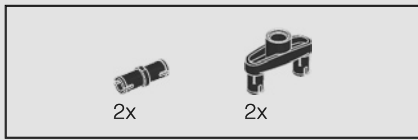

174

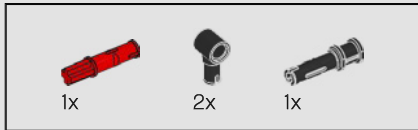
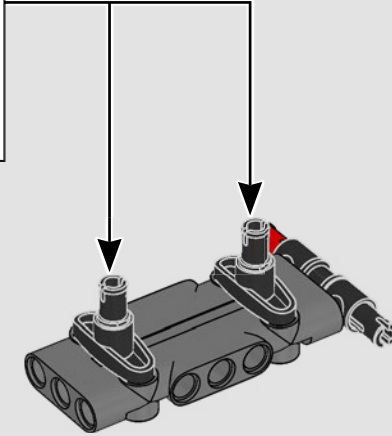
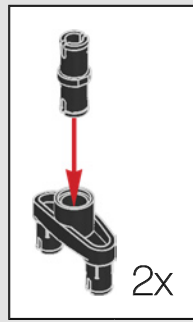

175

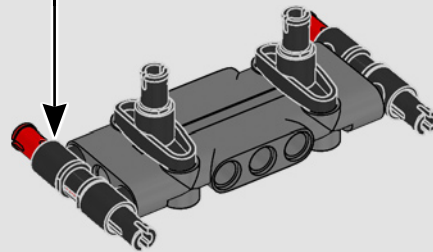
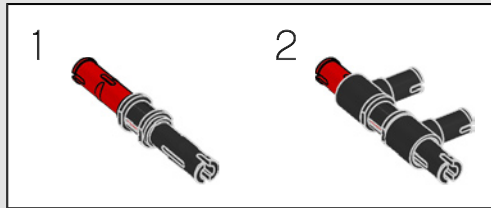

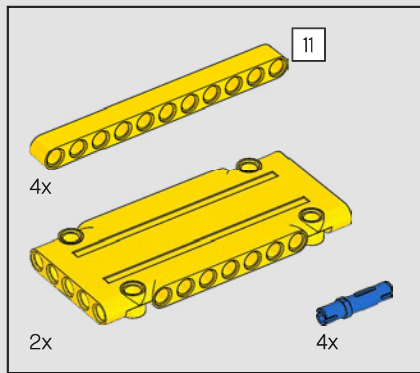

176

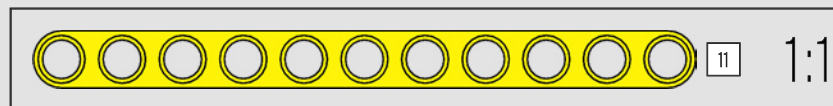
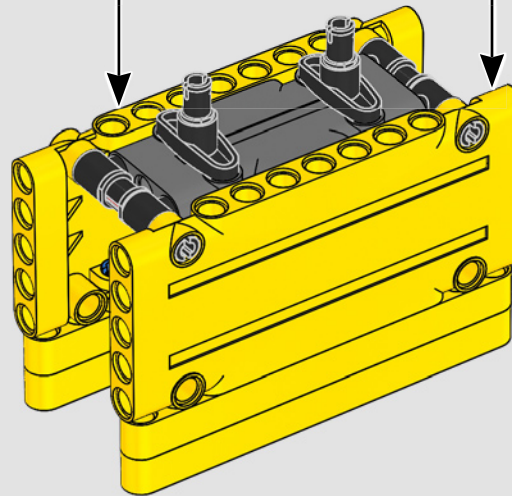
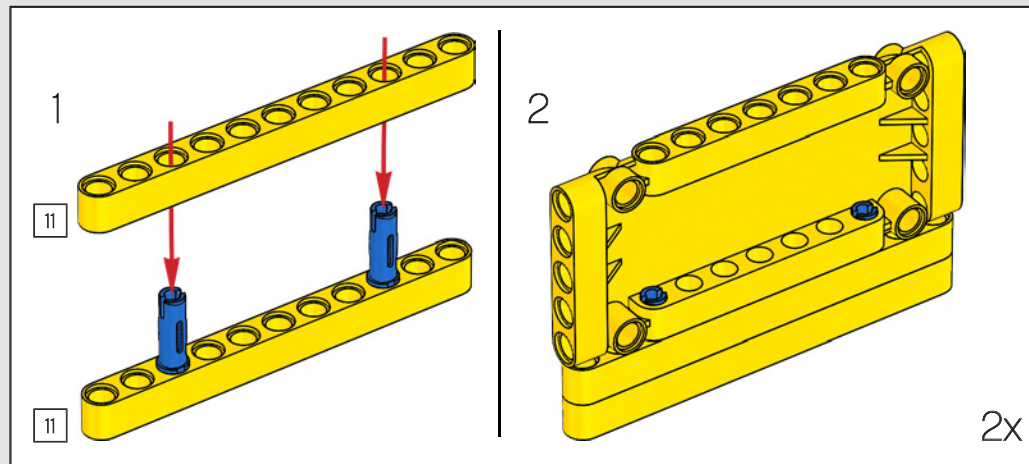

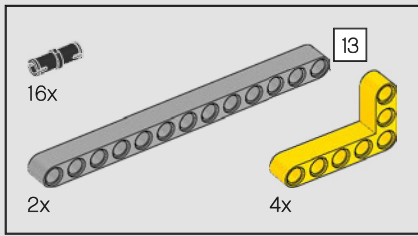

177

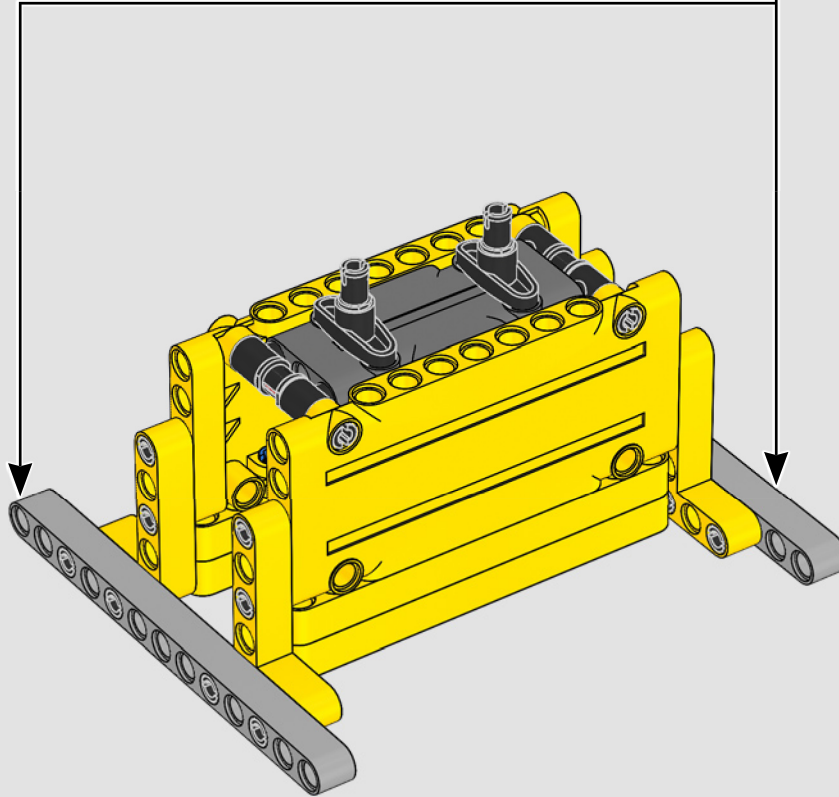
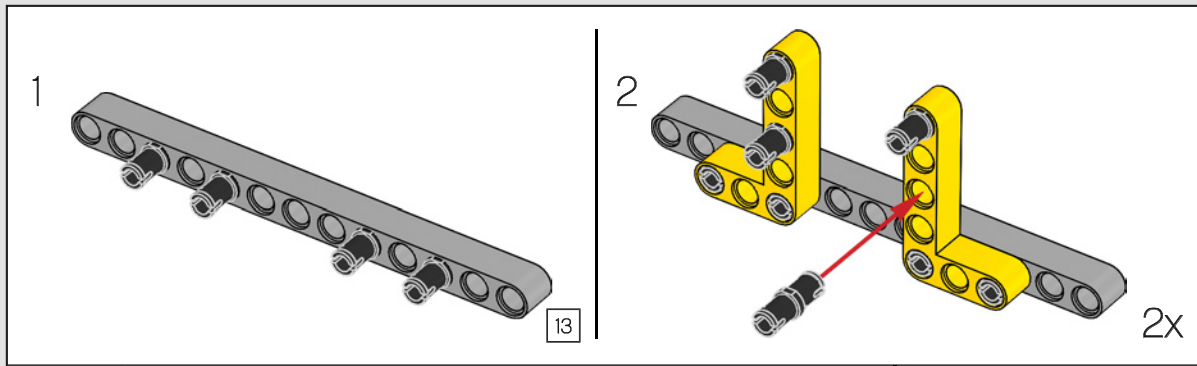

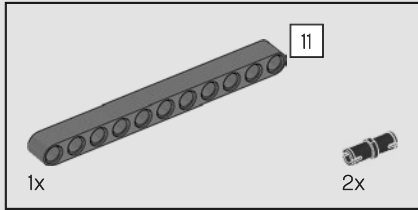
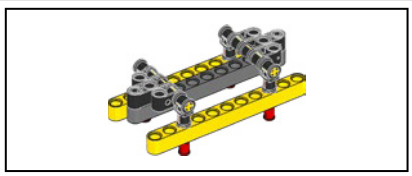

178

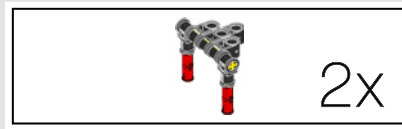
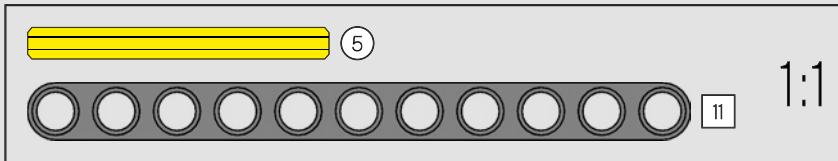
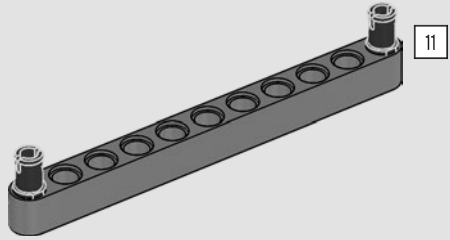

2x

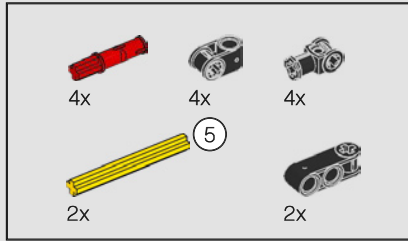

179

1

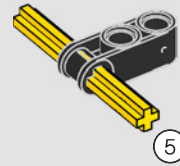

2

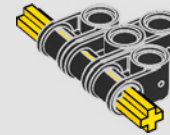

3

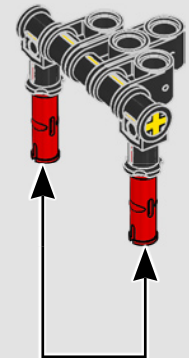

2x

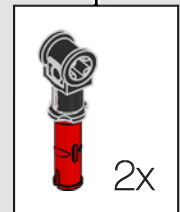

180

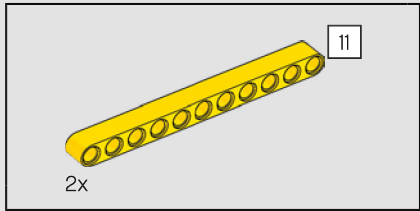
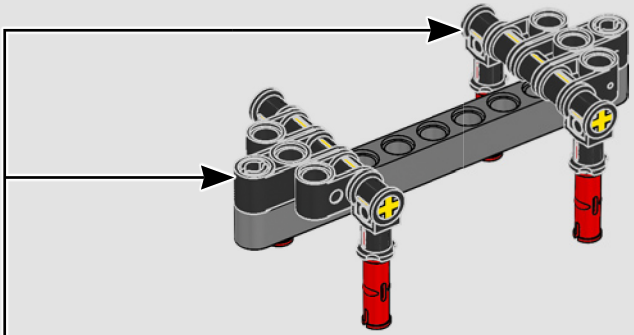

181

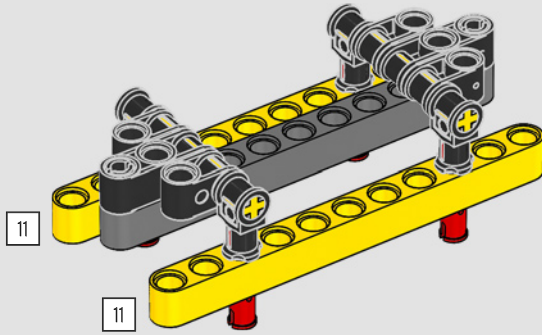

182

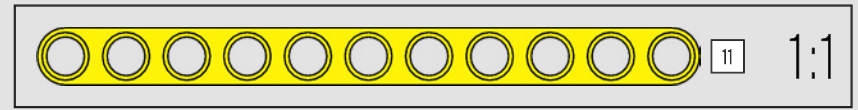
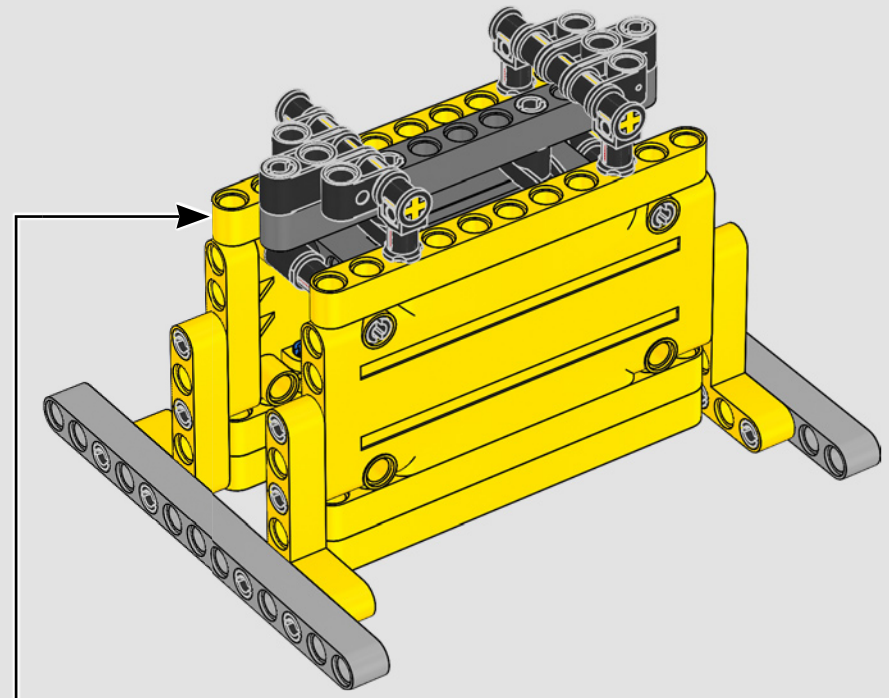

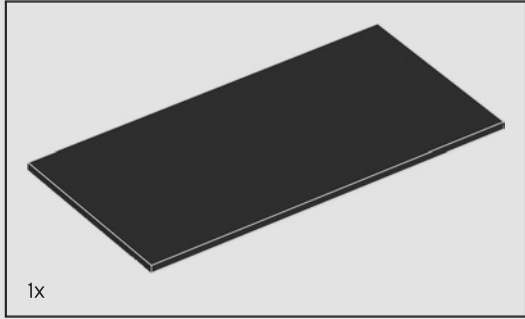
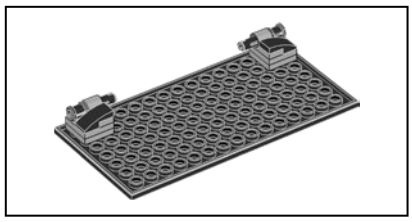

1x

183

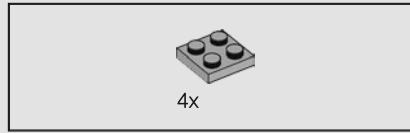
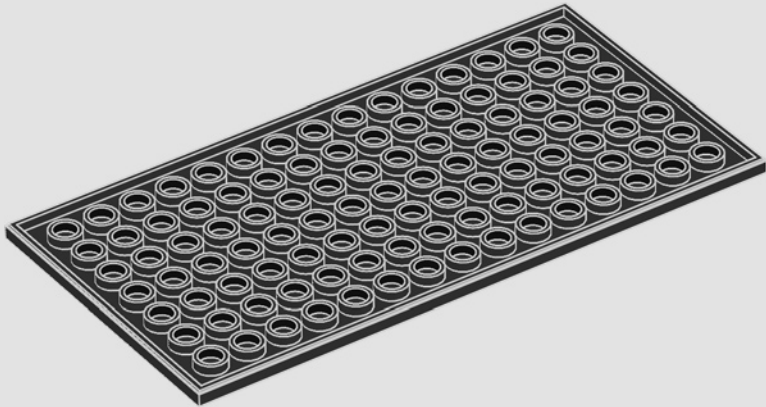

4x

184

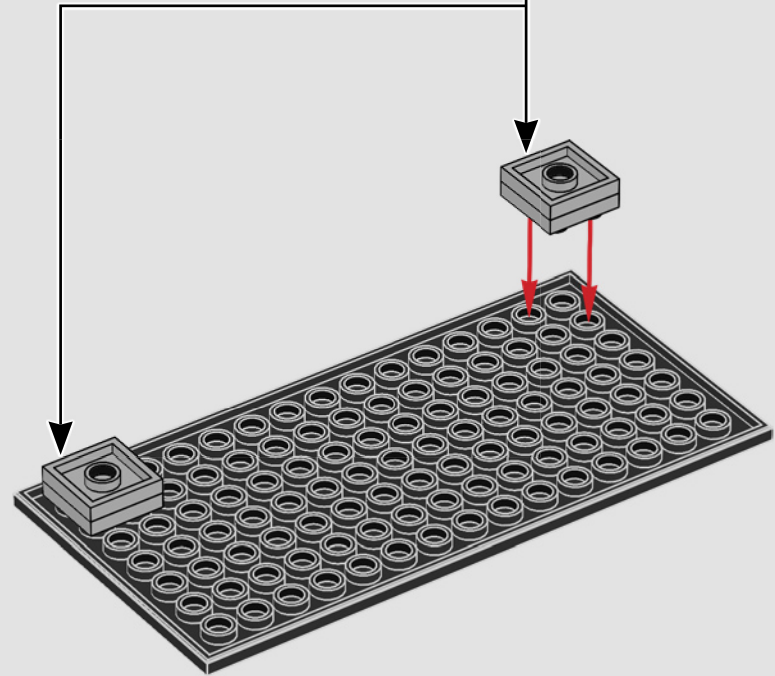
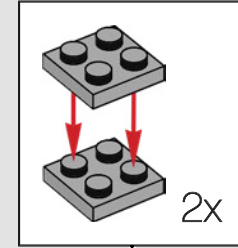

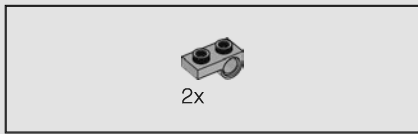

185

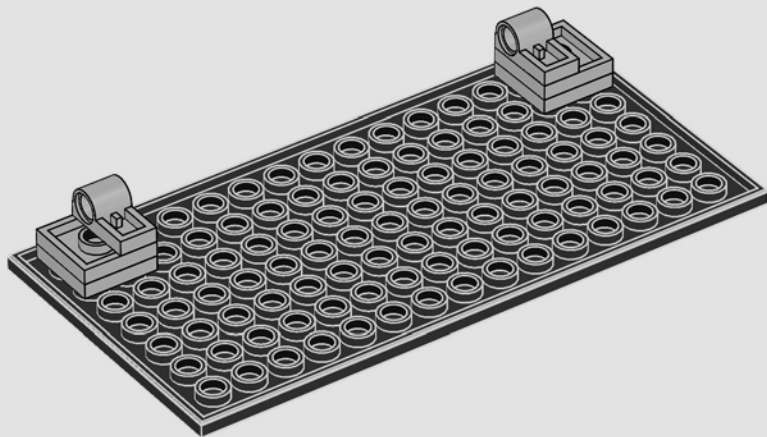

186

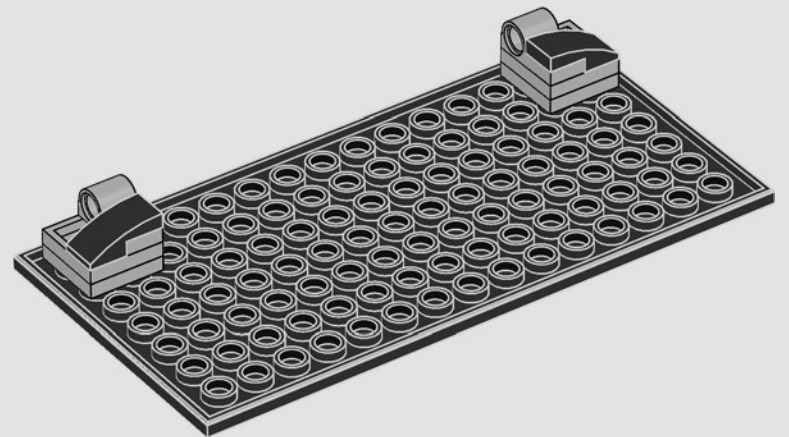

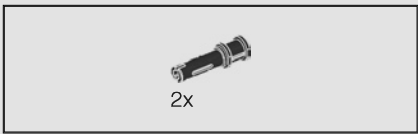

187

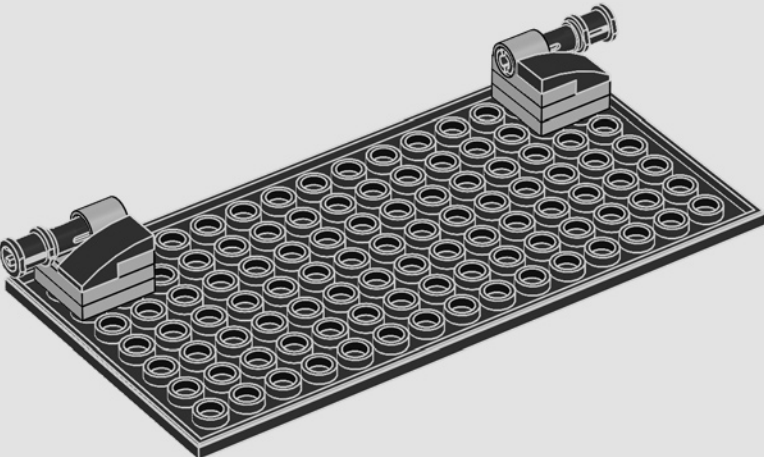

188

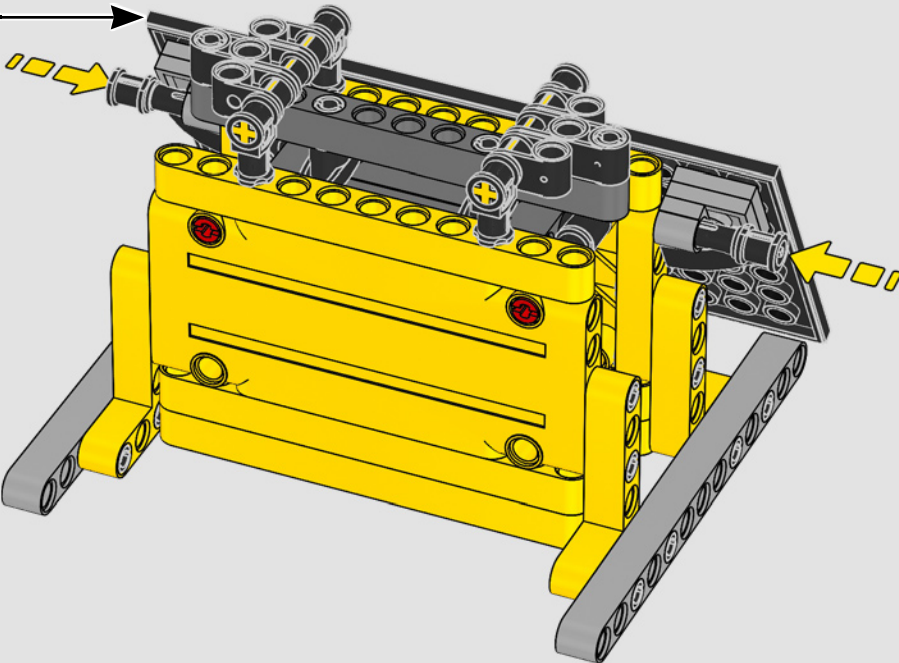

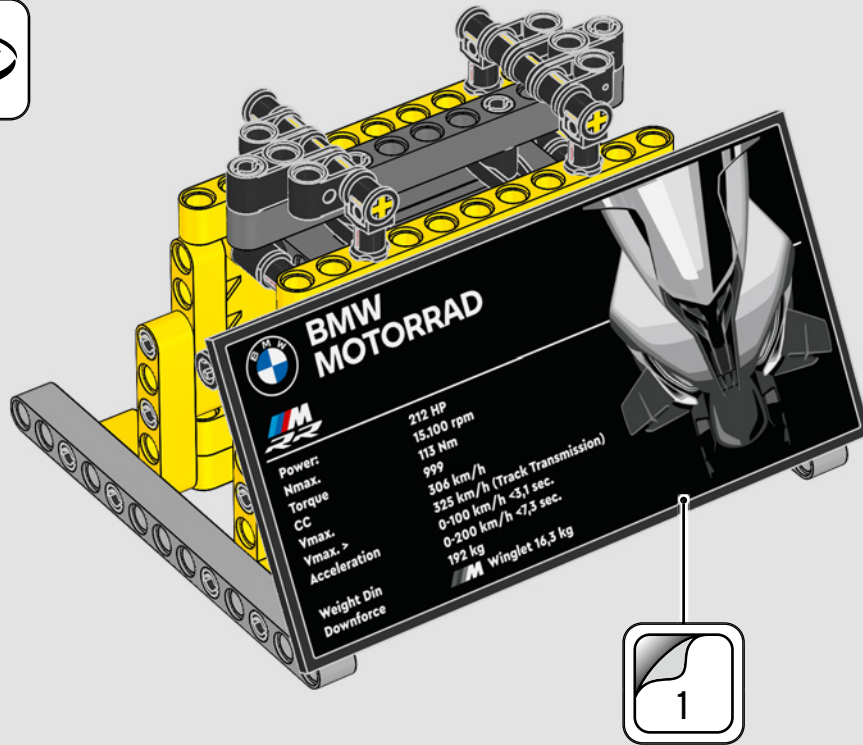

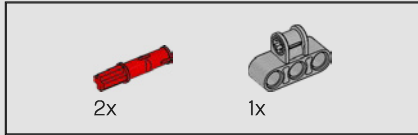
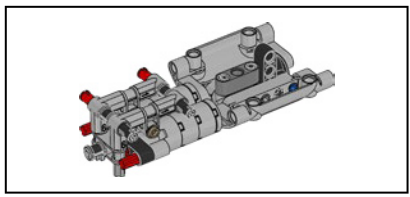

190

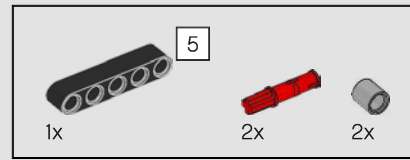
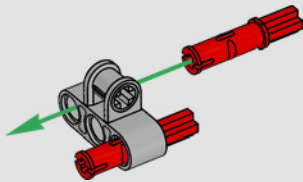

191

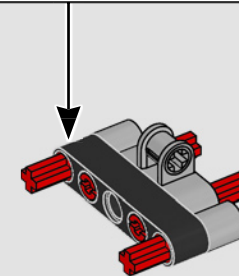
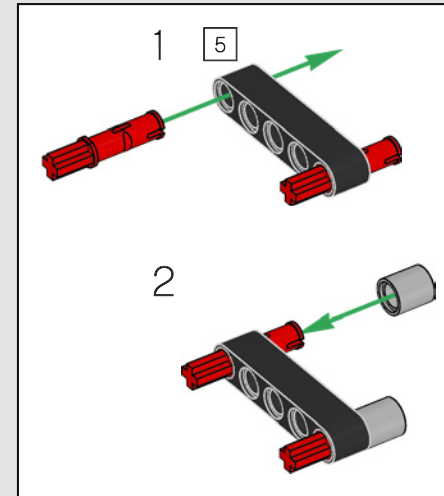

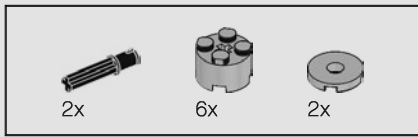

192

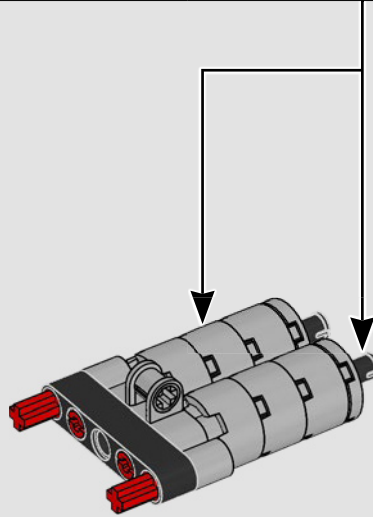
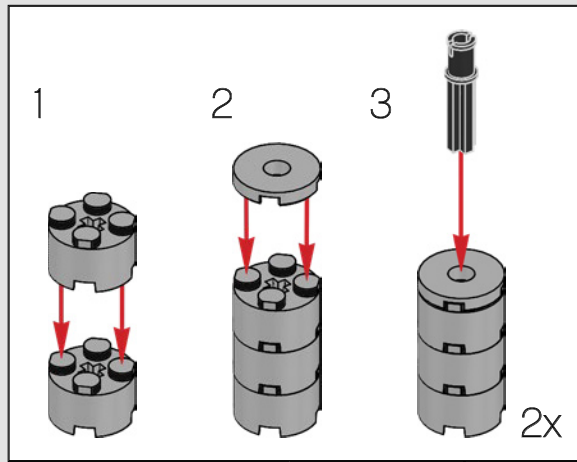

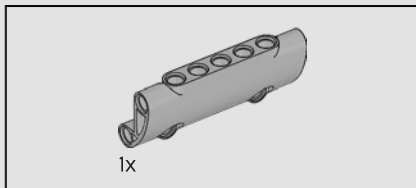
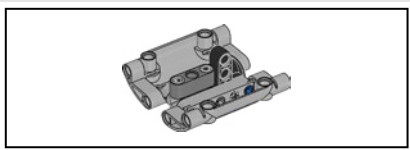

193

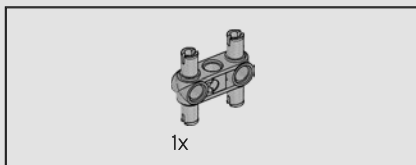
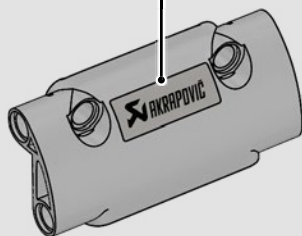

194

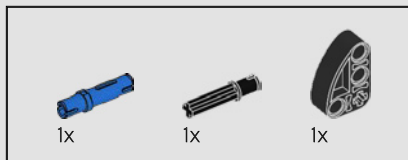
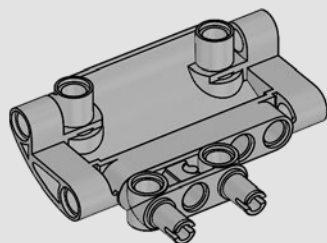

195

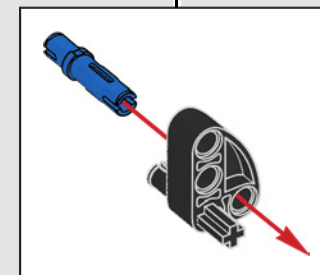
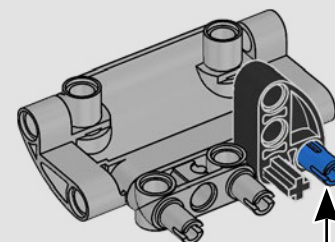

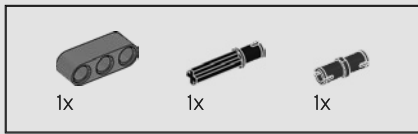

196

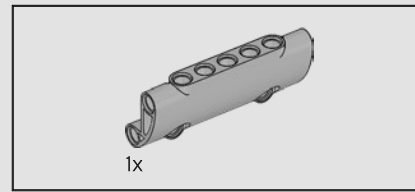
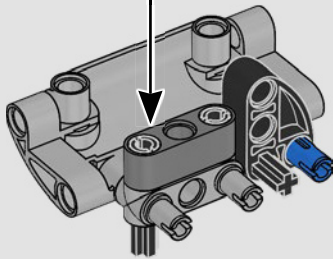
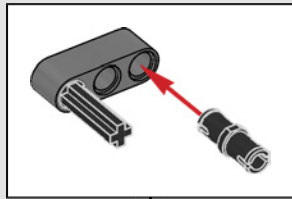

197

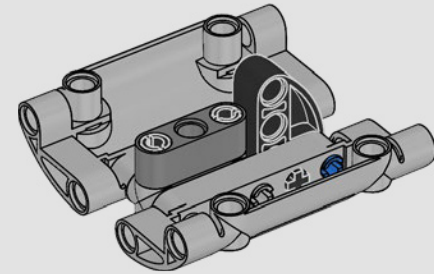
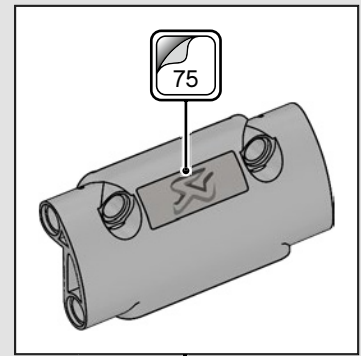

198

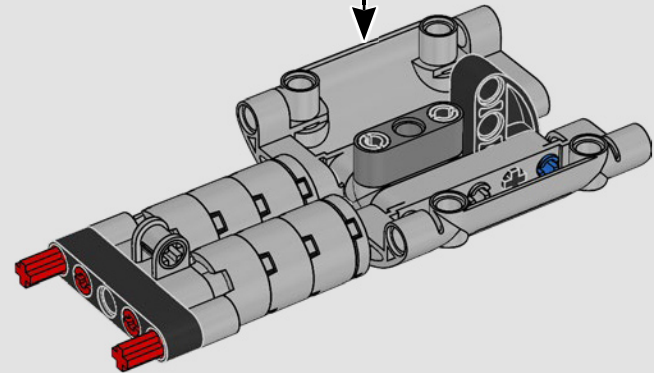

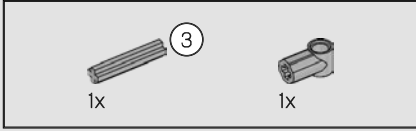
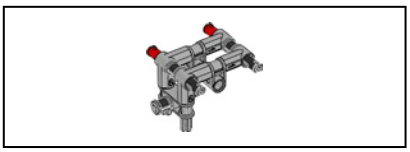

199

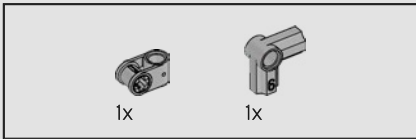
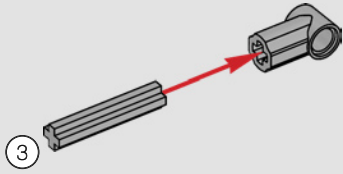

200

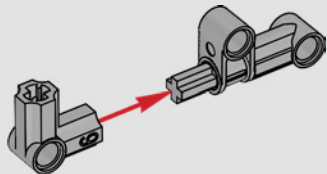

201

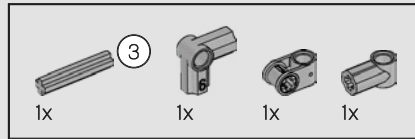
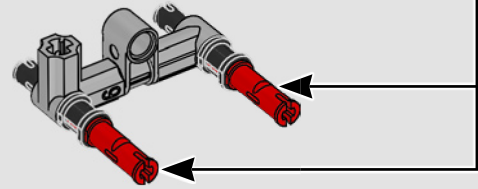
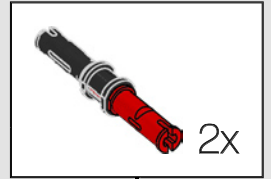

202

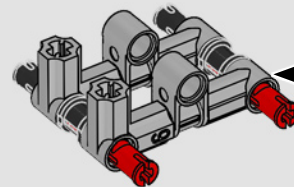
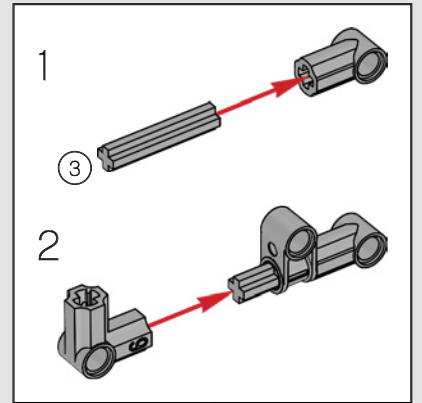

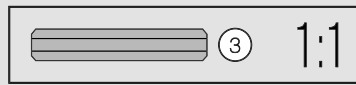
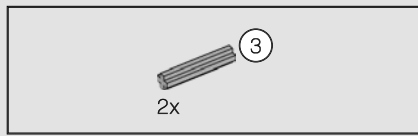

203

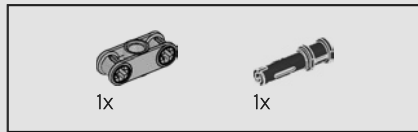
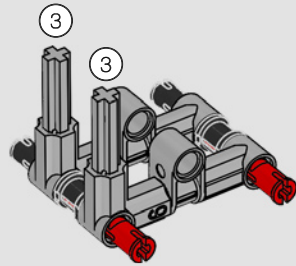

204

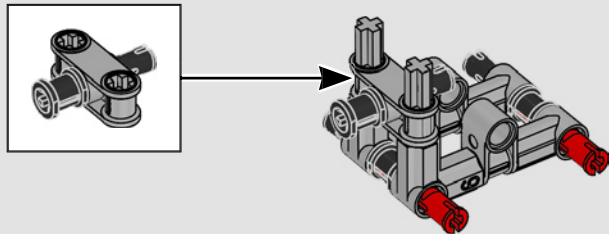

205

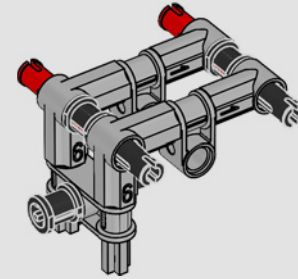
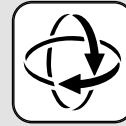

206

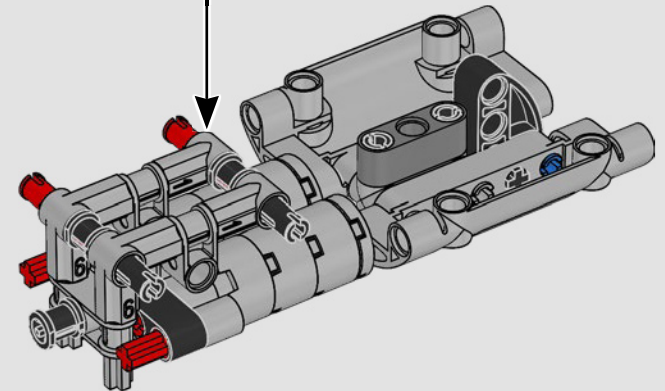

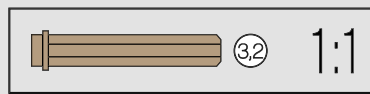
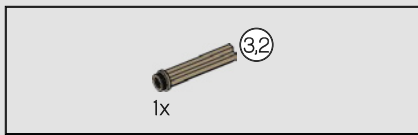

207

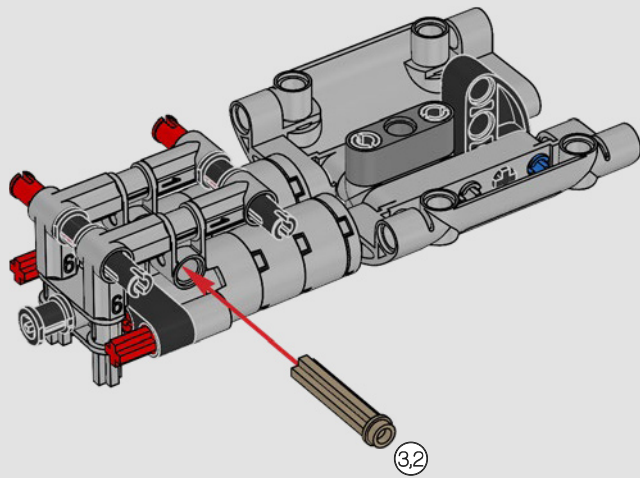

208

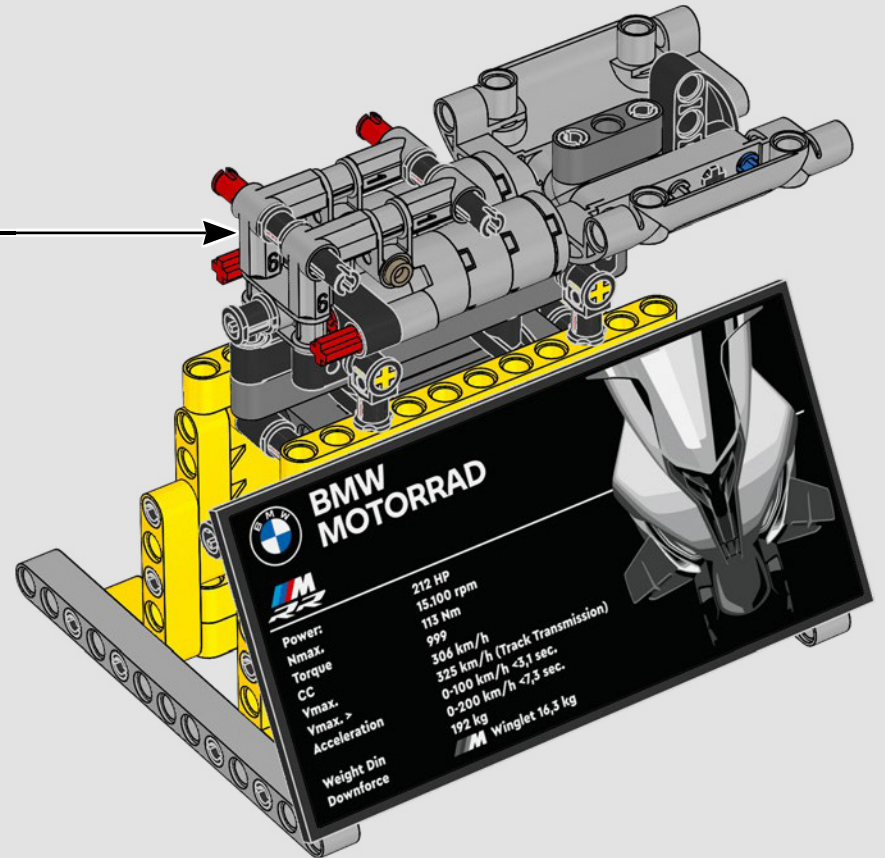

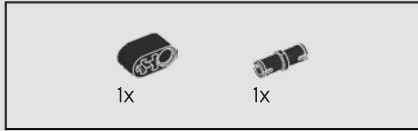
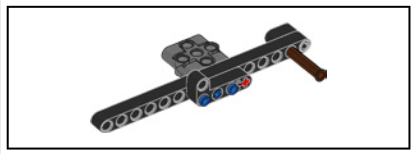

209

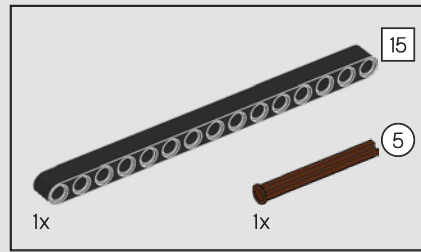
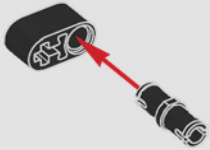

210

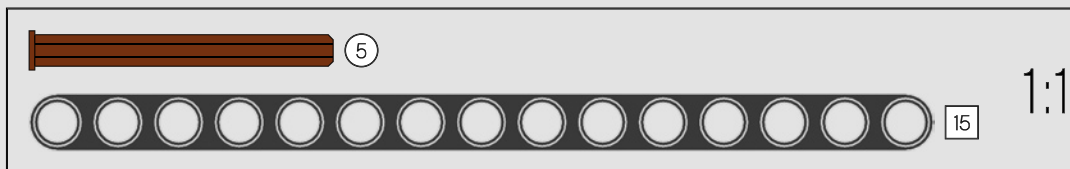
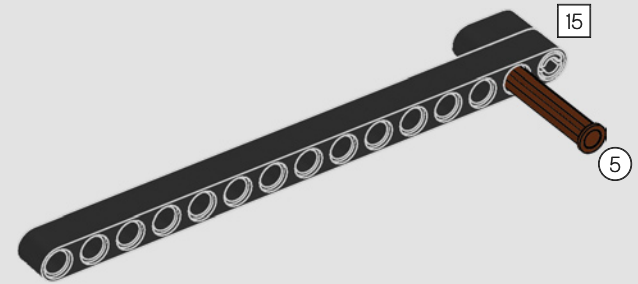

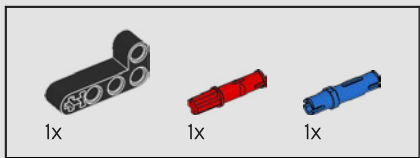

211

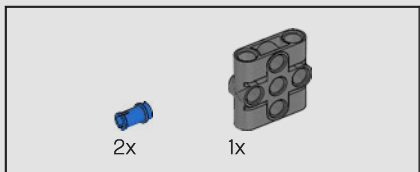
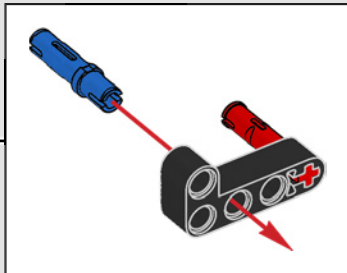
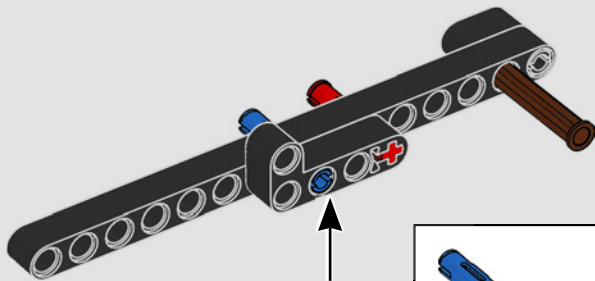

212

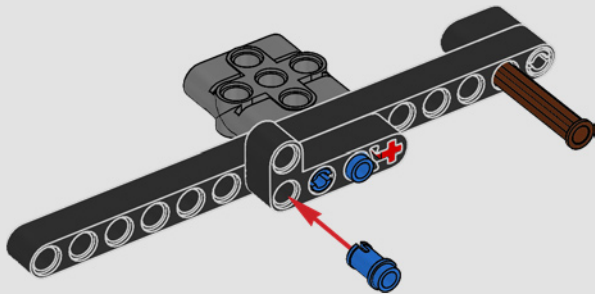

213

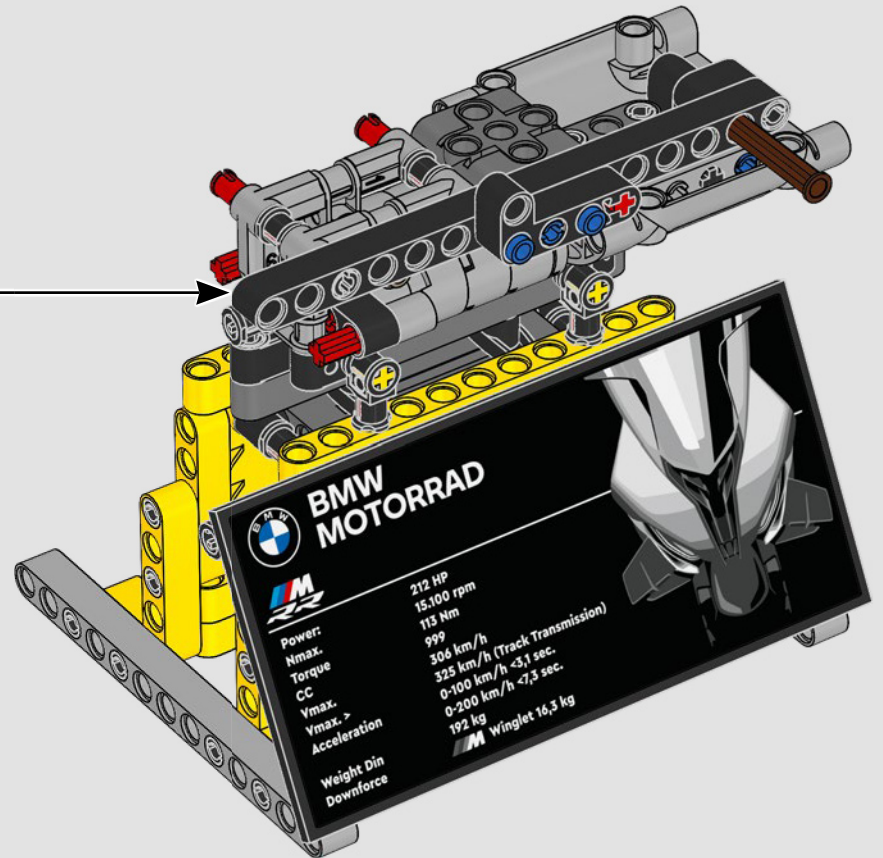

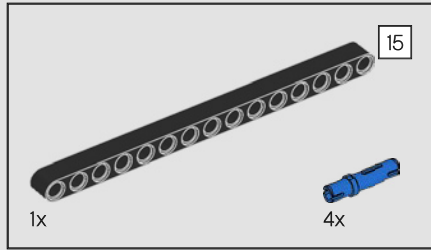
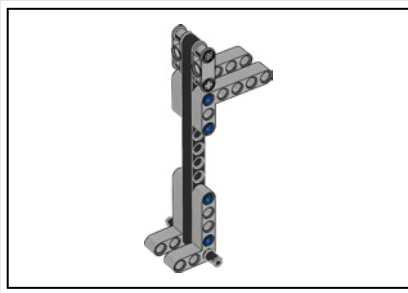

214

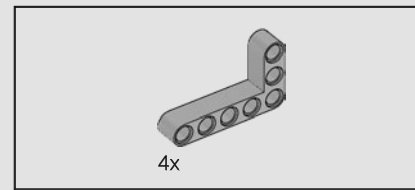
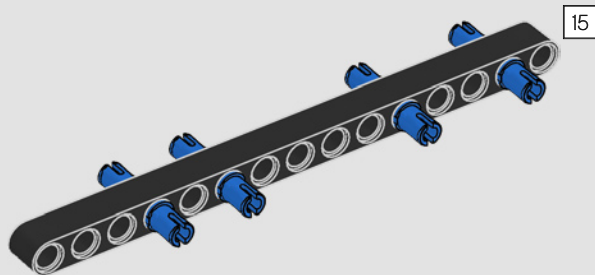

215

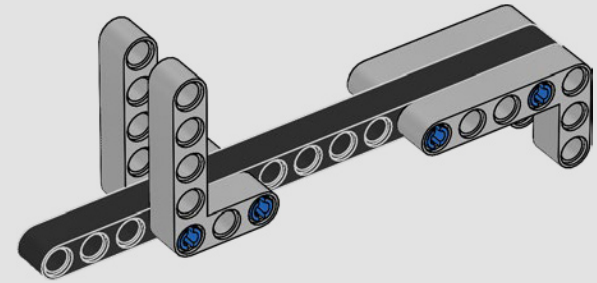

216

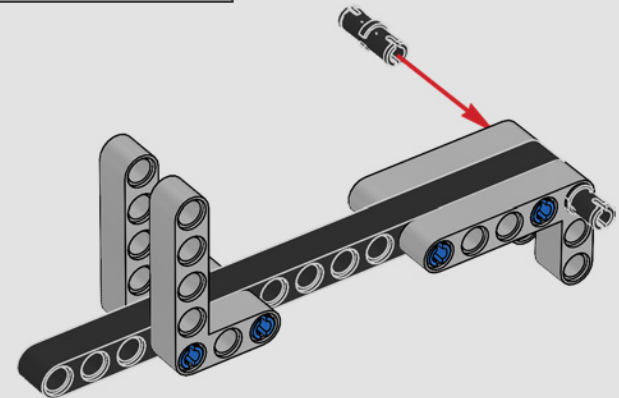

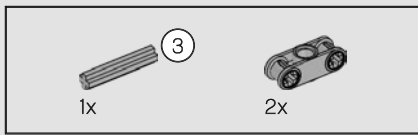

217

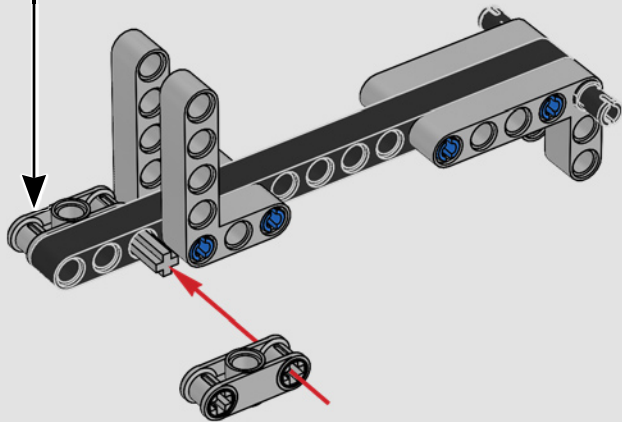
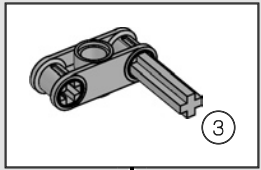

218

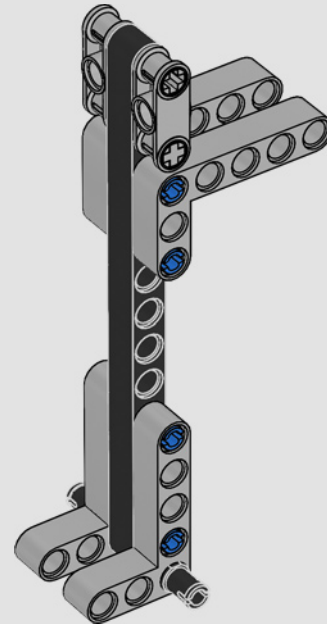
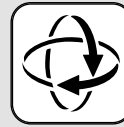

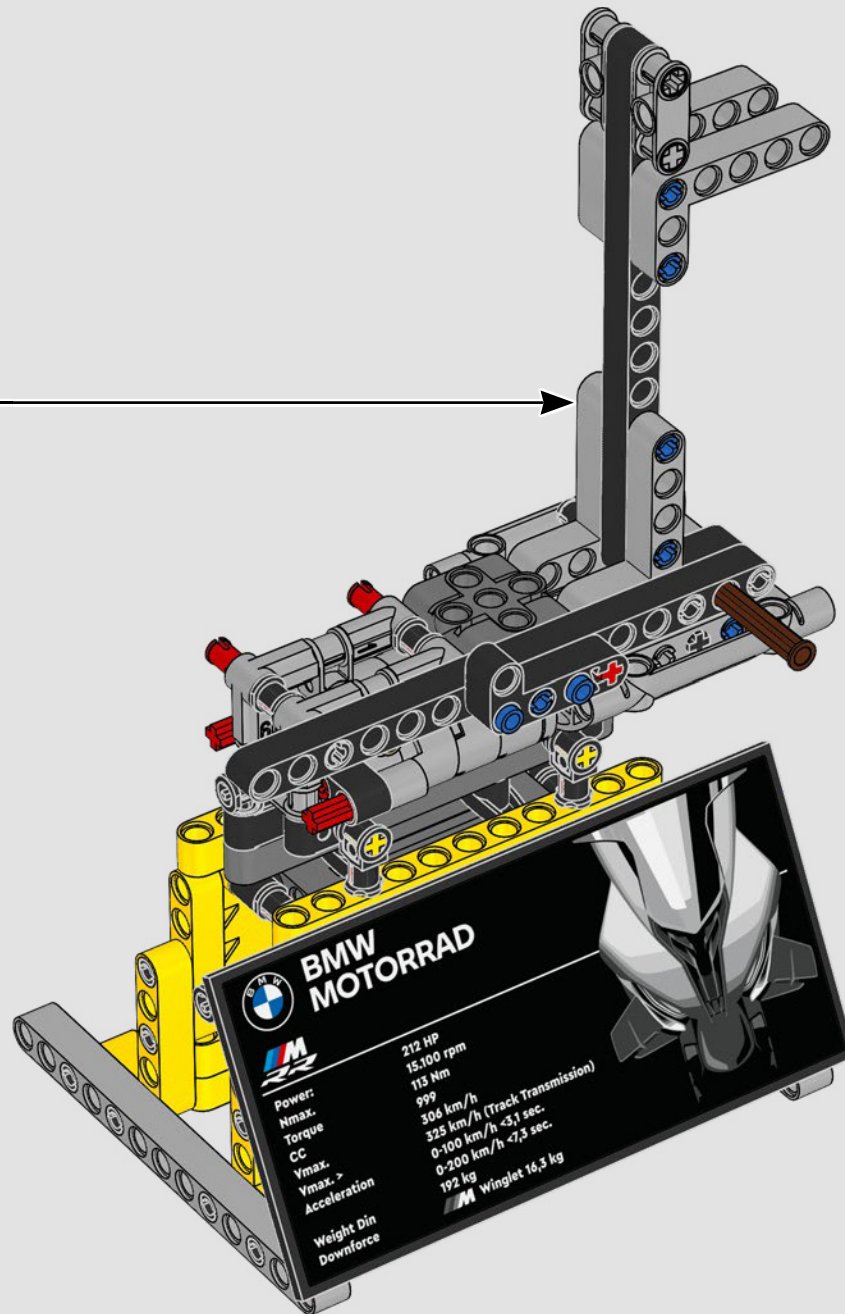

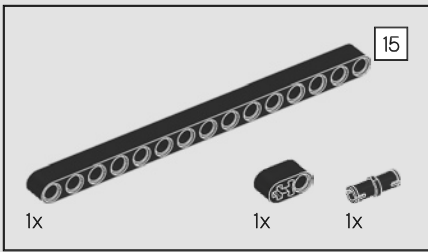

220

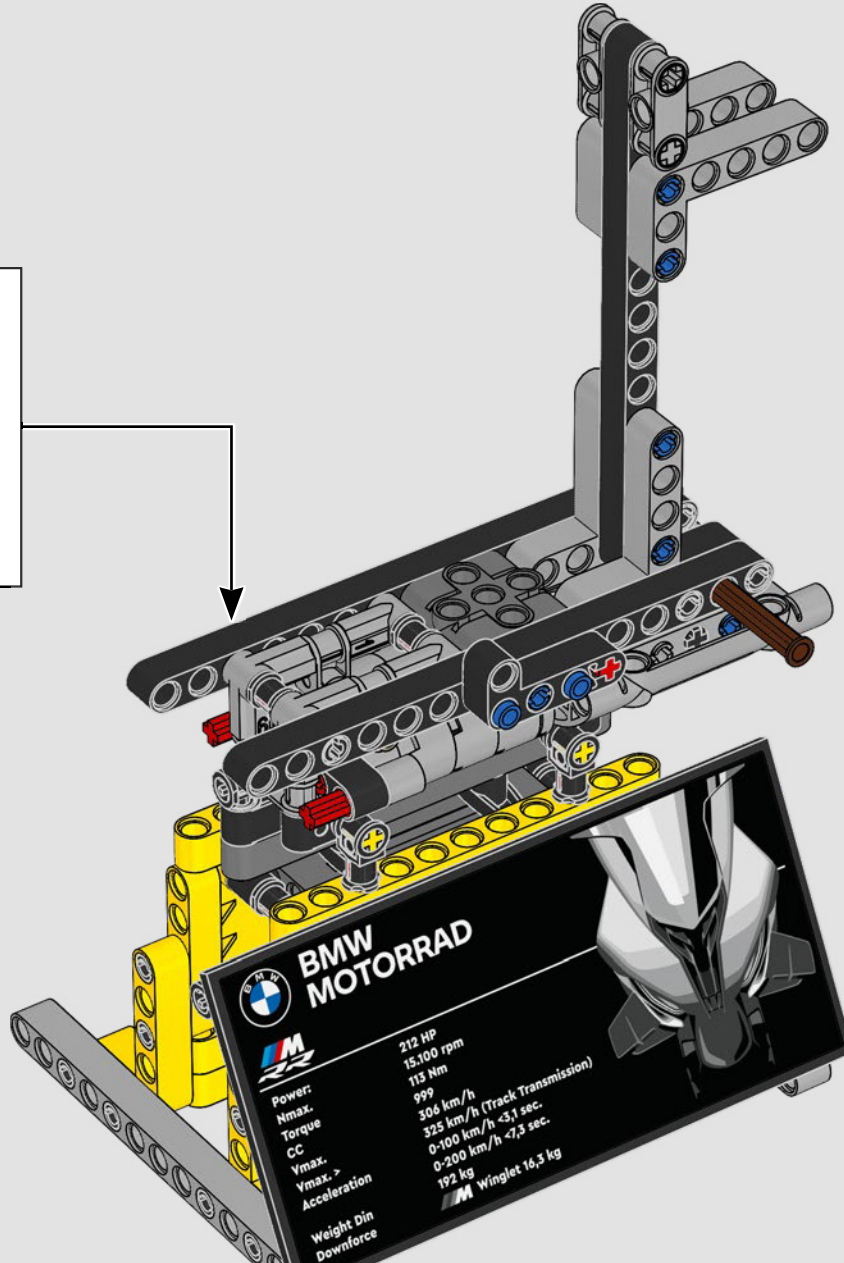
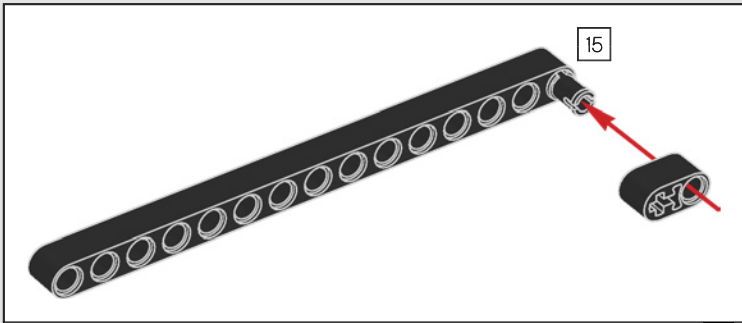

221

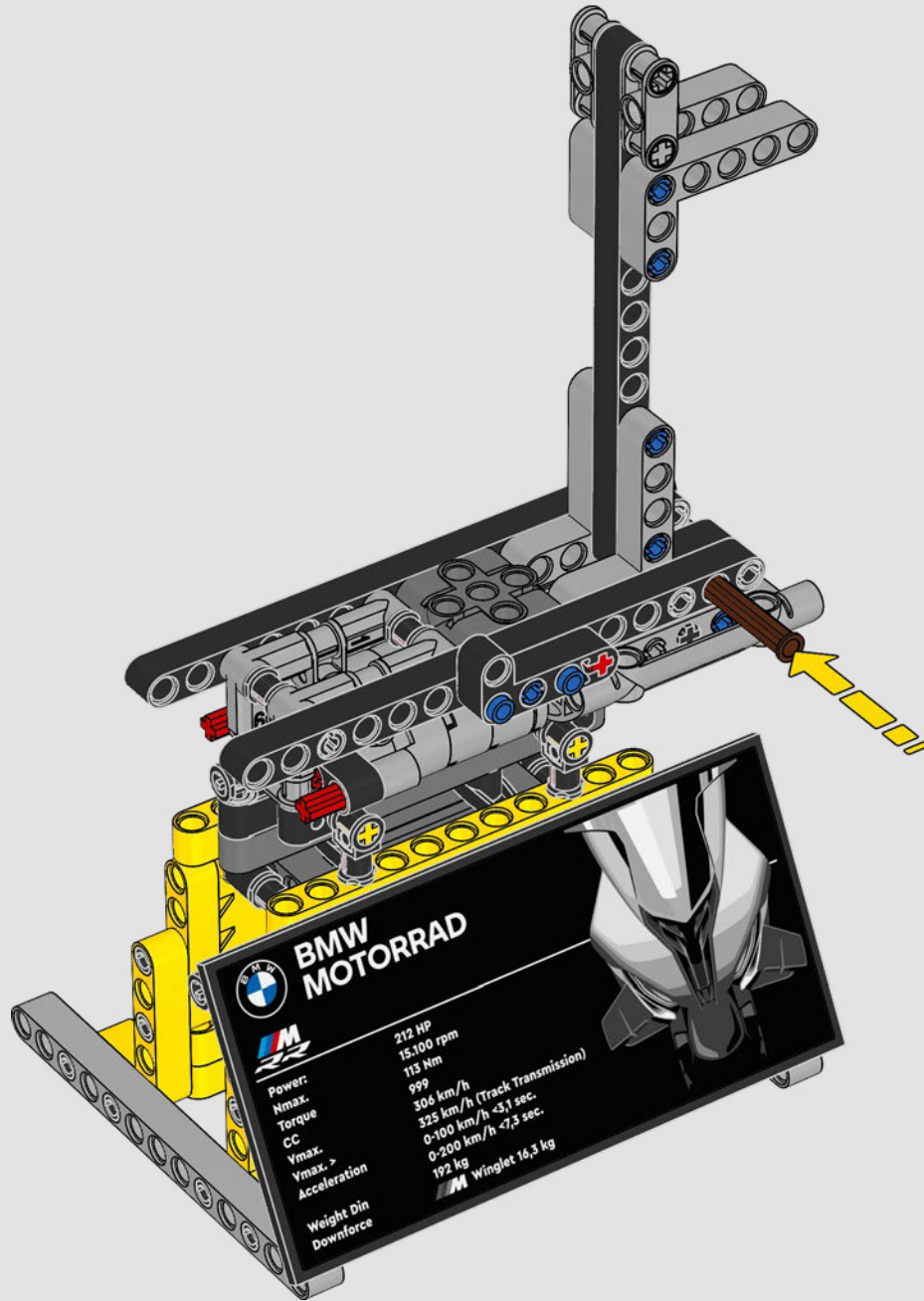

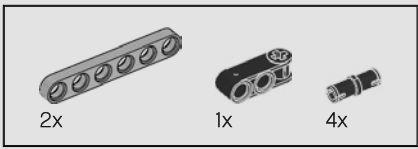

222

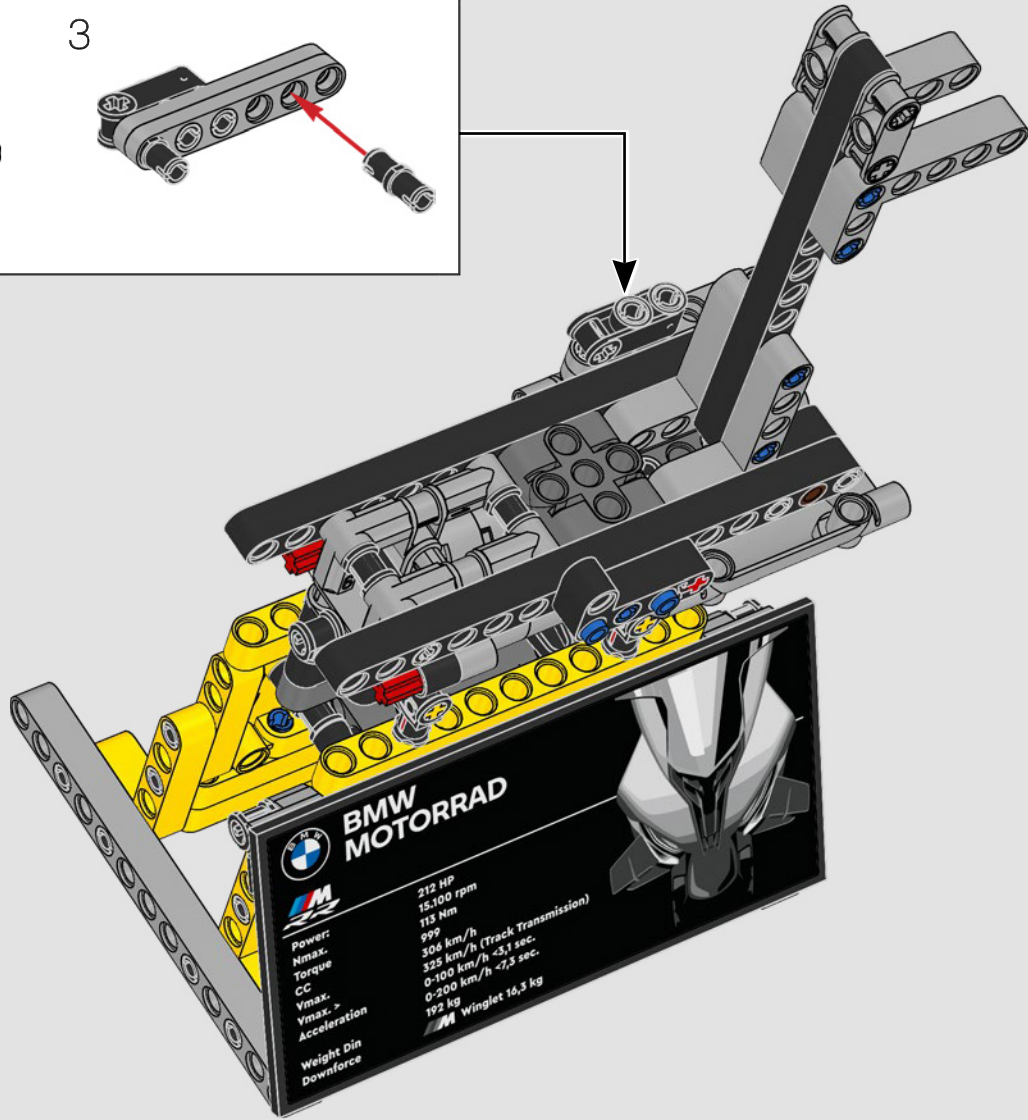
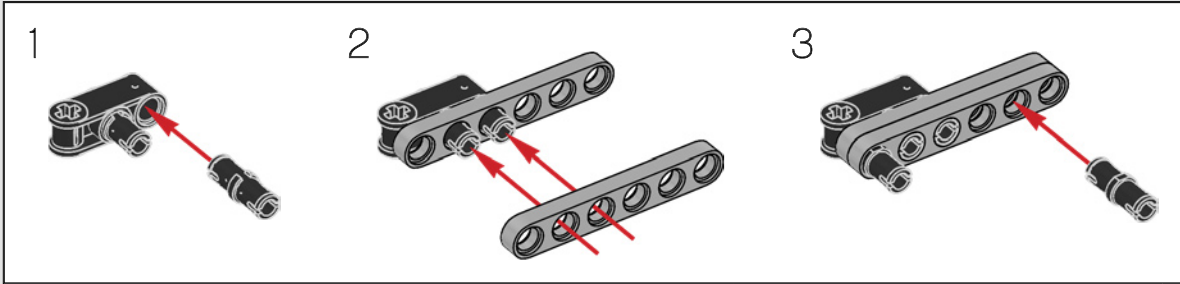

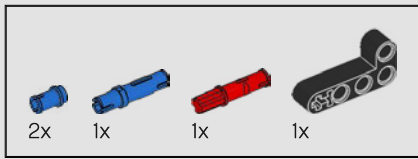

223

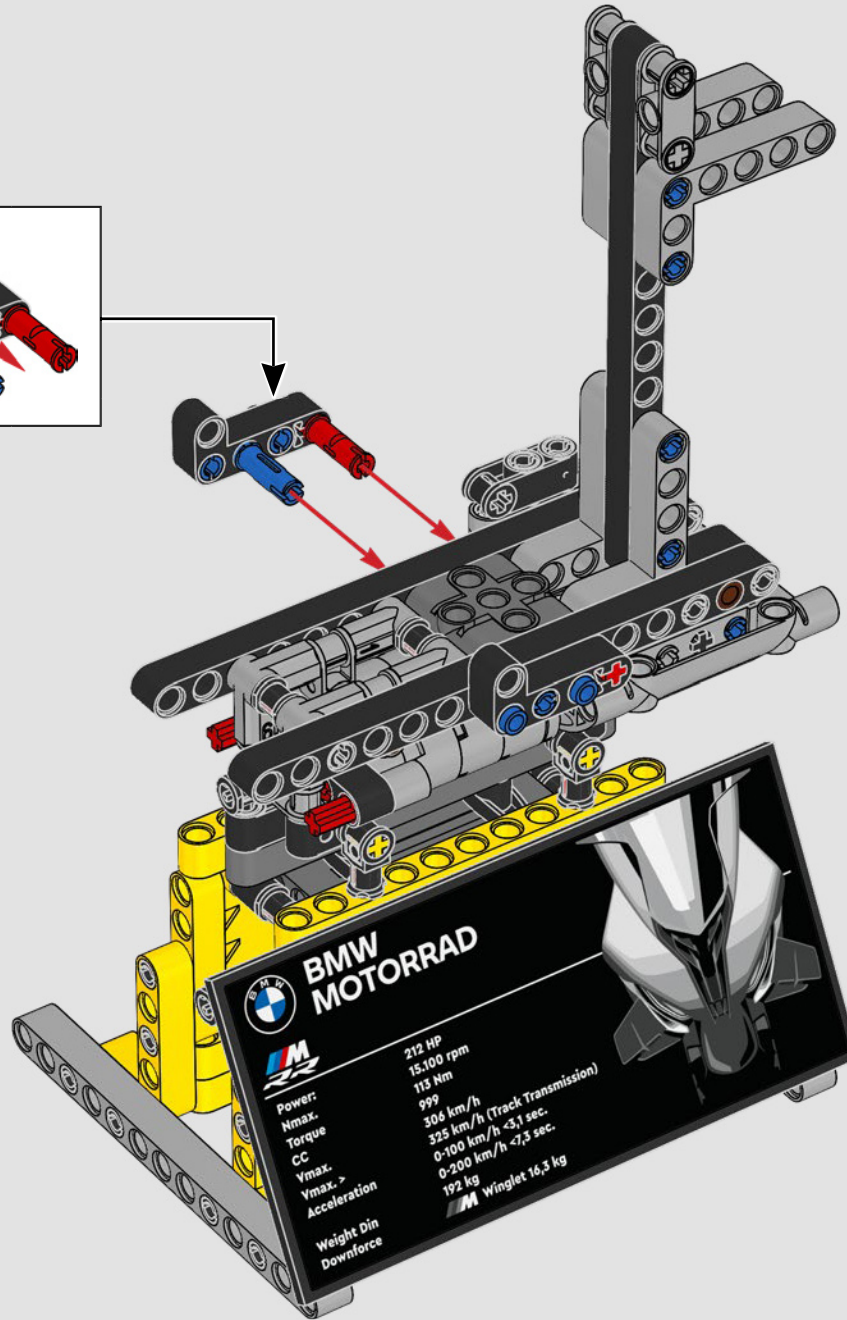
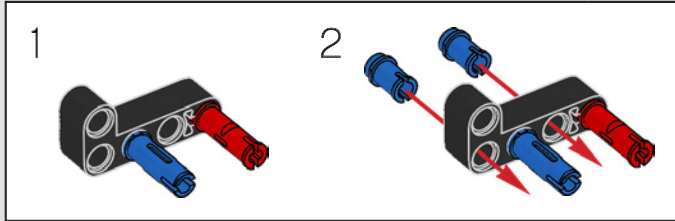

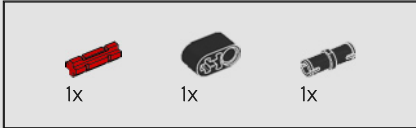
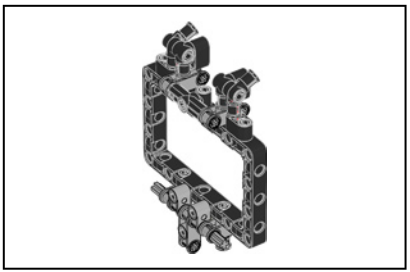

224

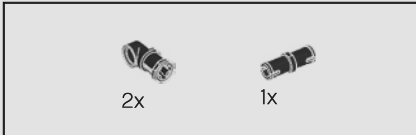
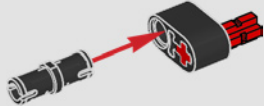

225

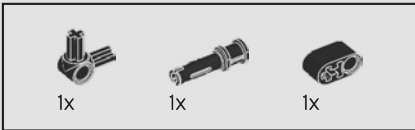
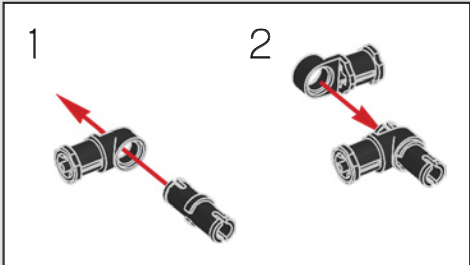

226

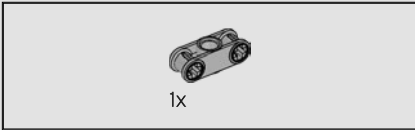
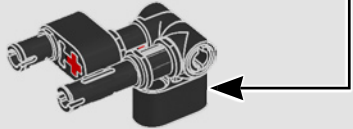
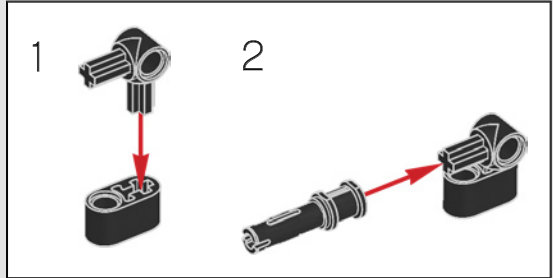

227

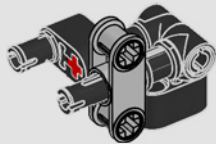

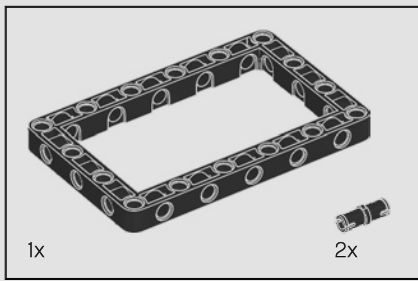

228

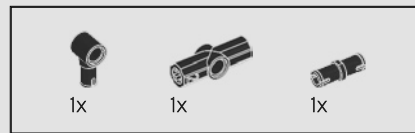
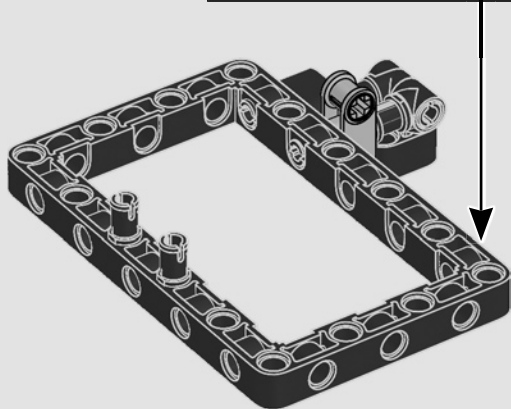
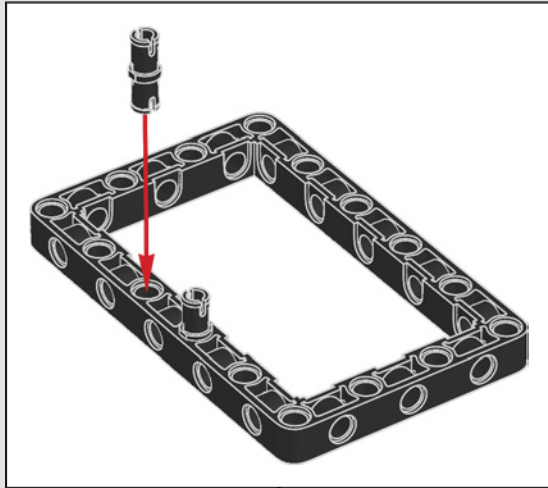

229

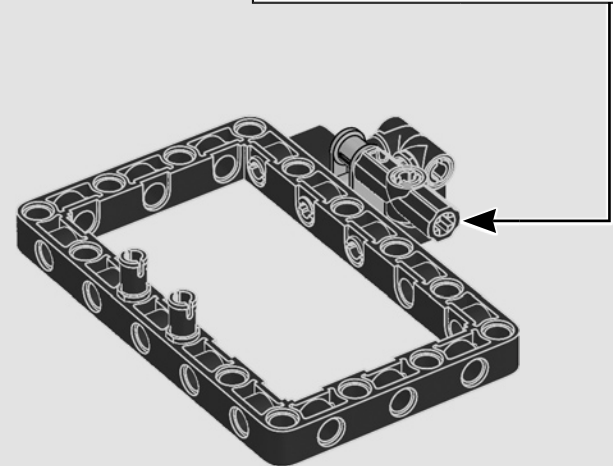
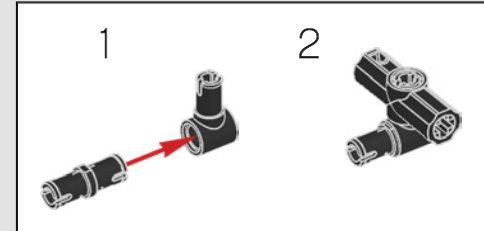

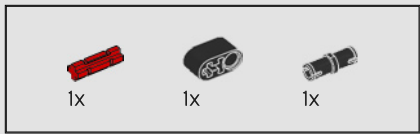

230

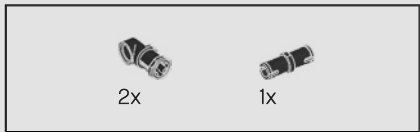

231

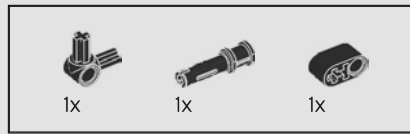
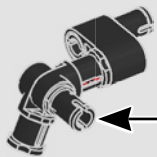
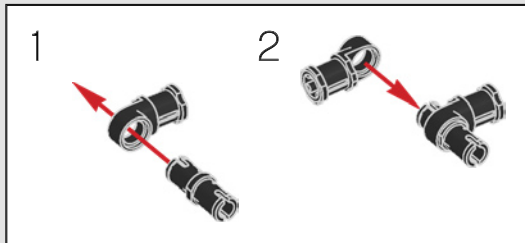

232

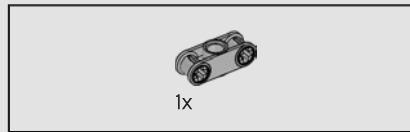
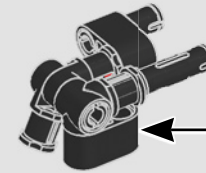
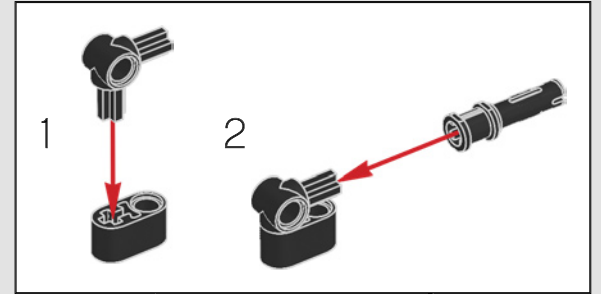

233



234

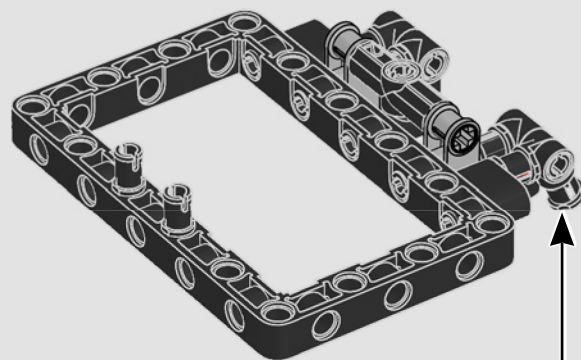

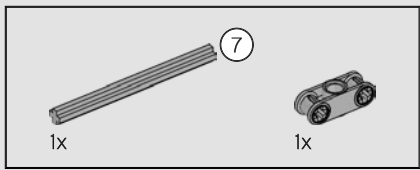

235

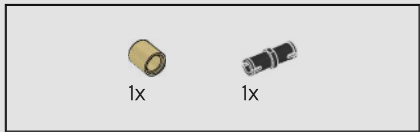
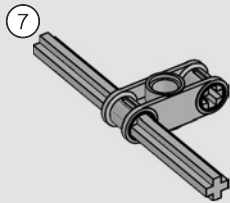

236

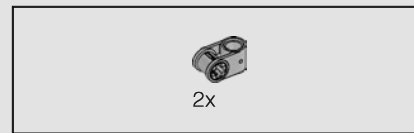
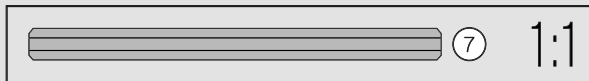
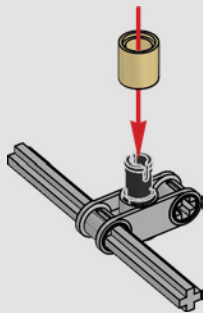

237

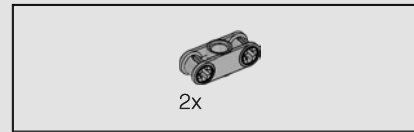
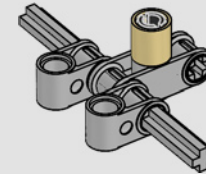

238

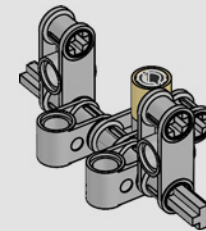

239

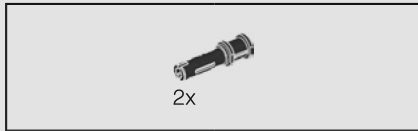
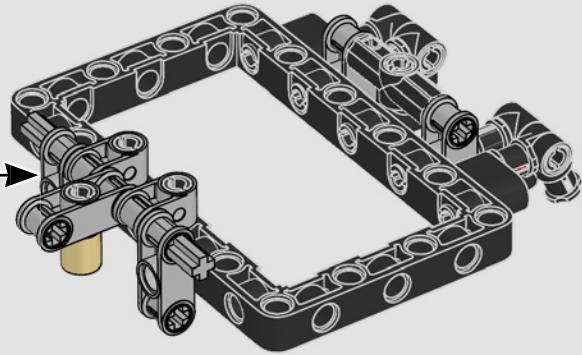

240

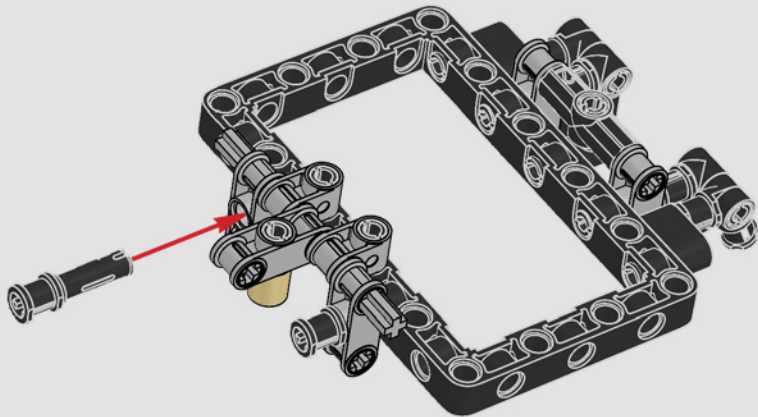

241

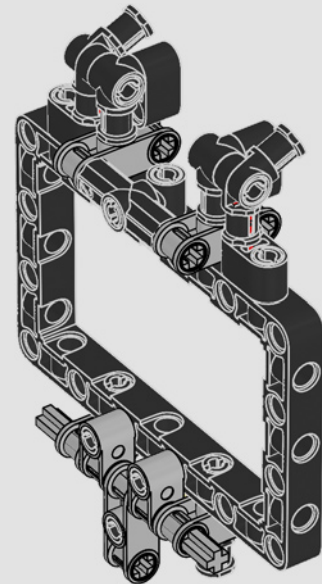
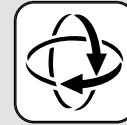

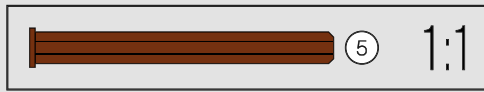
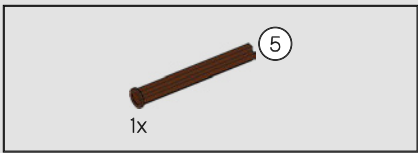

242

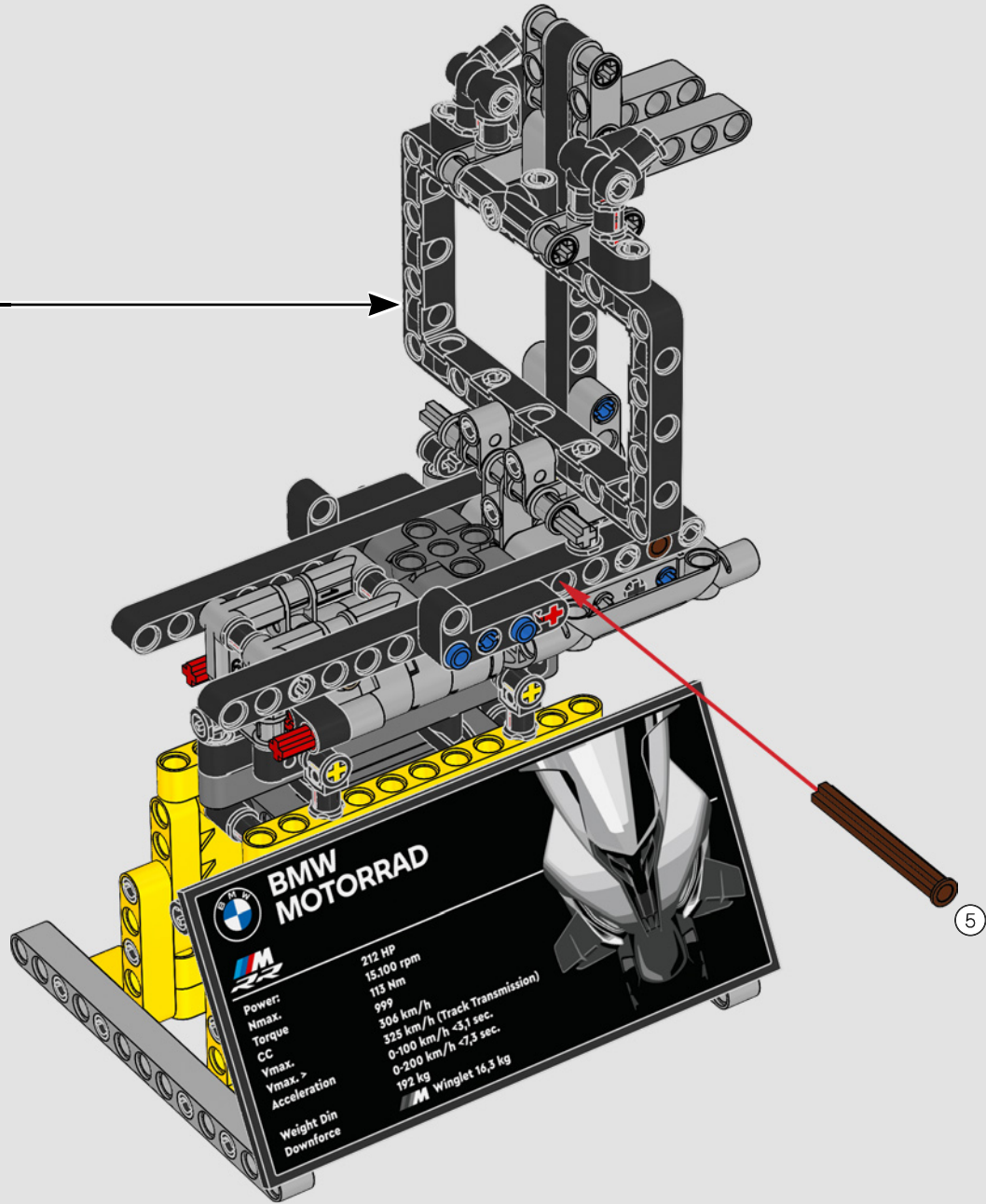

BMW MOTORRAD

Power:	212 HP
Nmax:	15,100 rpm
Torque	113 Nm
CC	999
Vmax.	306 km/h
Acceleration	325 km/h (Track Transmission) 0-100 km/h < 3,1 sec. 0-200 km/h < 7,3 sec.
Weight Din	192 kg
Downforce	Winglet 16,3 kg

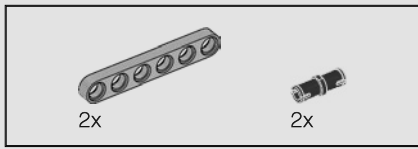

243

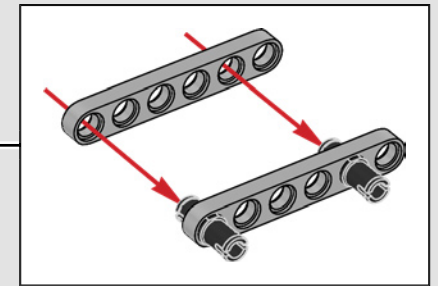
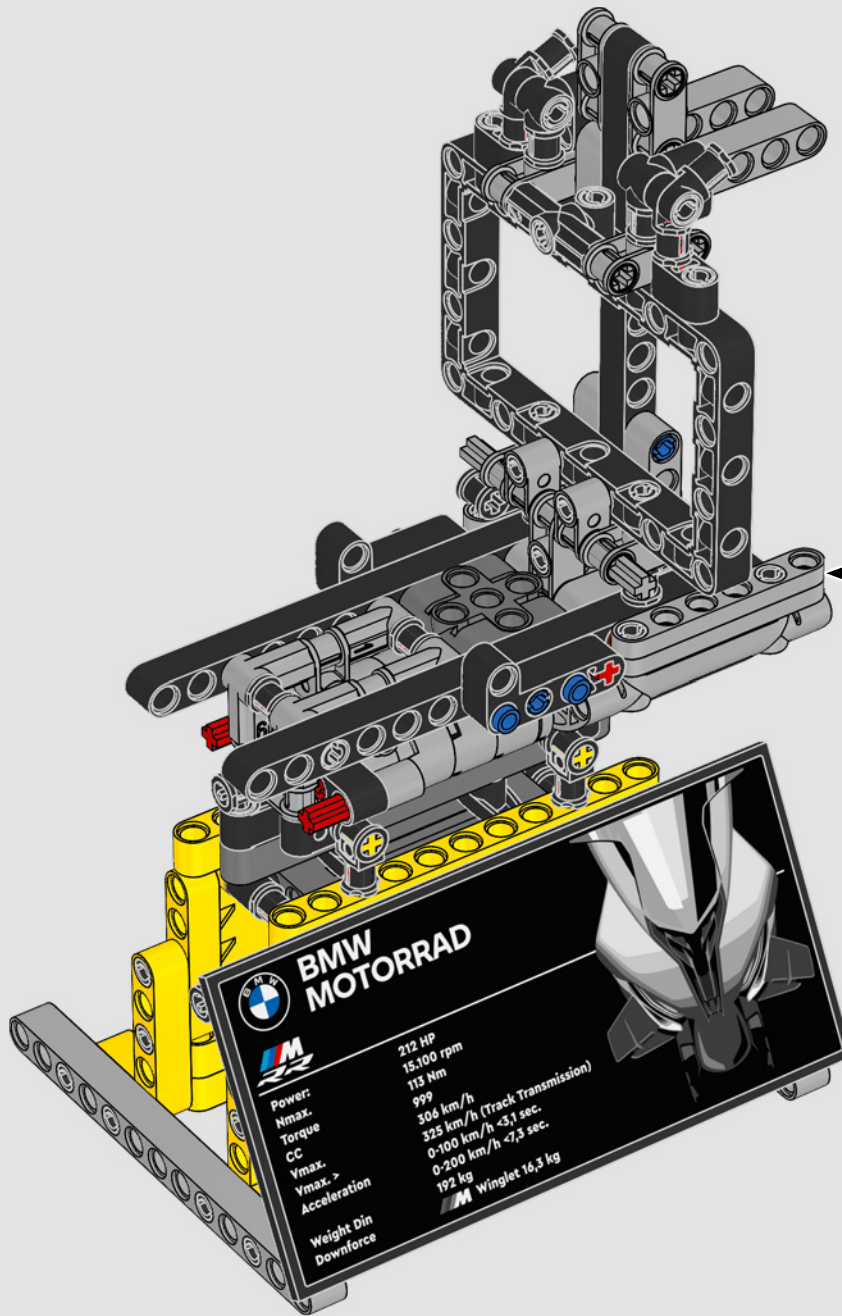

BMW MOTORRAD

Power: 212 HP
Nmax. 15,100 rpm
Torque 113 Nm
CC 999
Vmax. 306 km/h
0-100 km/h (Track Transmission) 3.25 km/h < 3.1 sec.
0-200 km/h < 7.3 sec.
Acceleration 192 kg
Weight Din 16.3 kg
Downforce

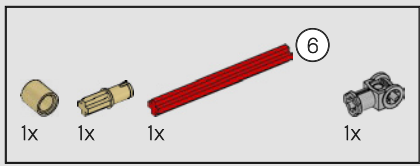

244

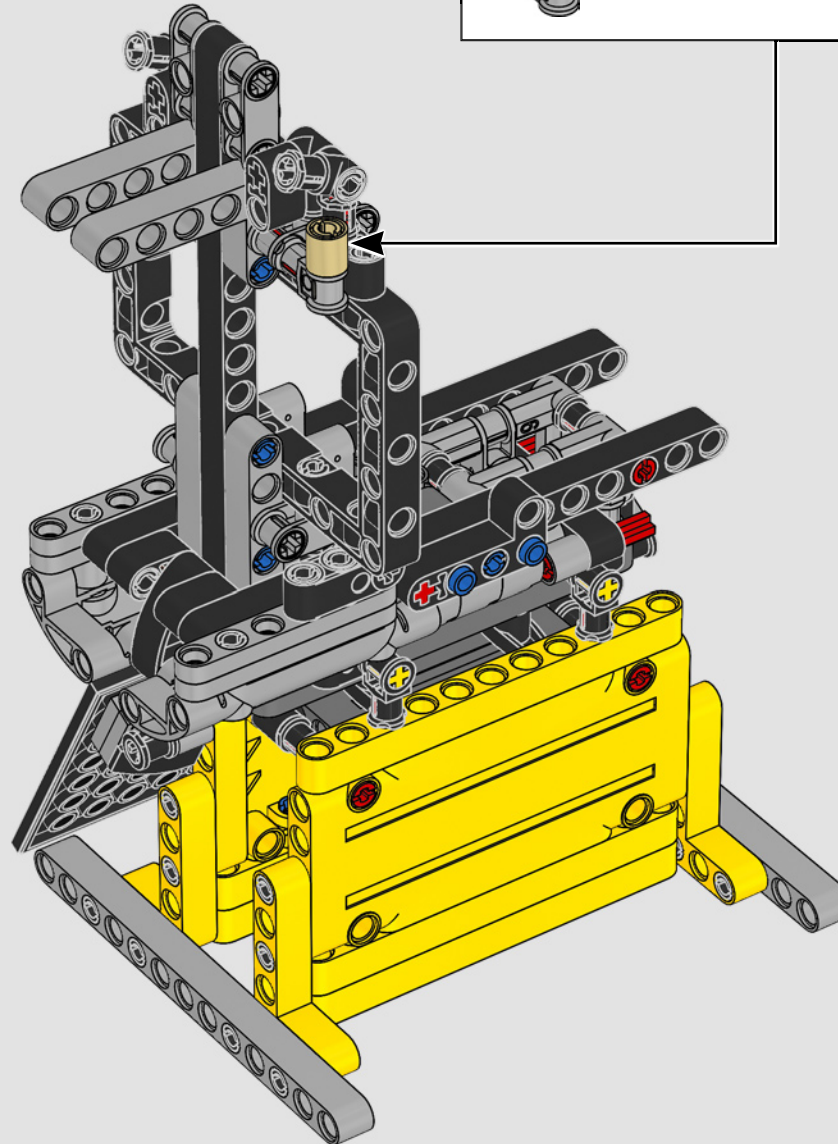
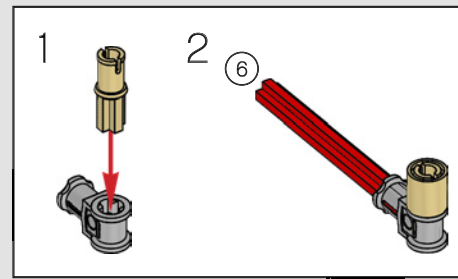
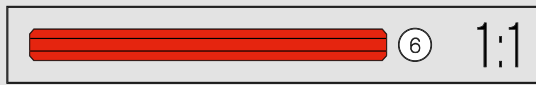

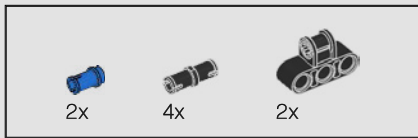

245

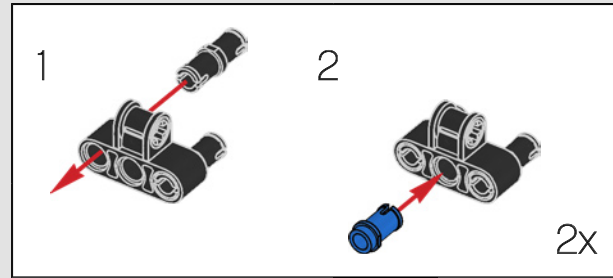
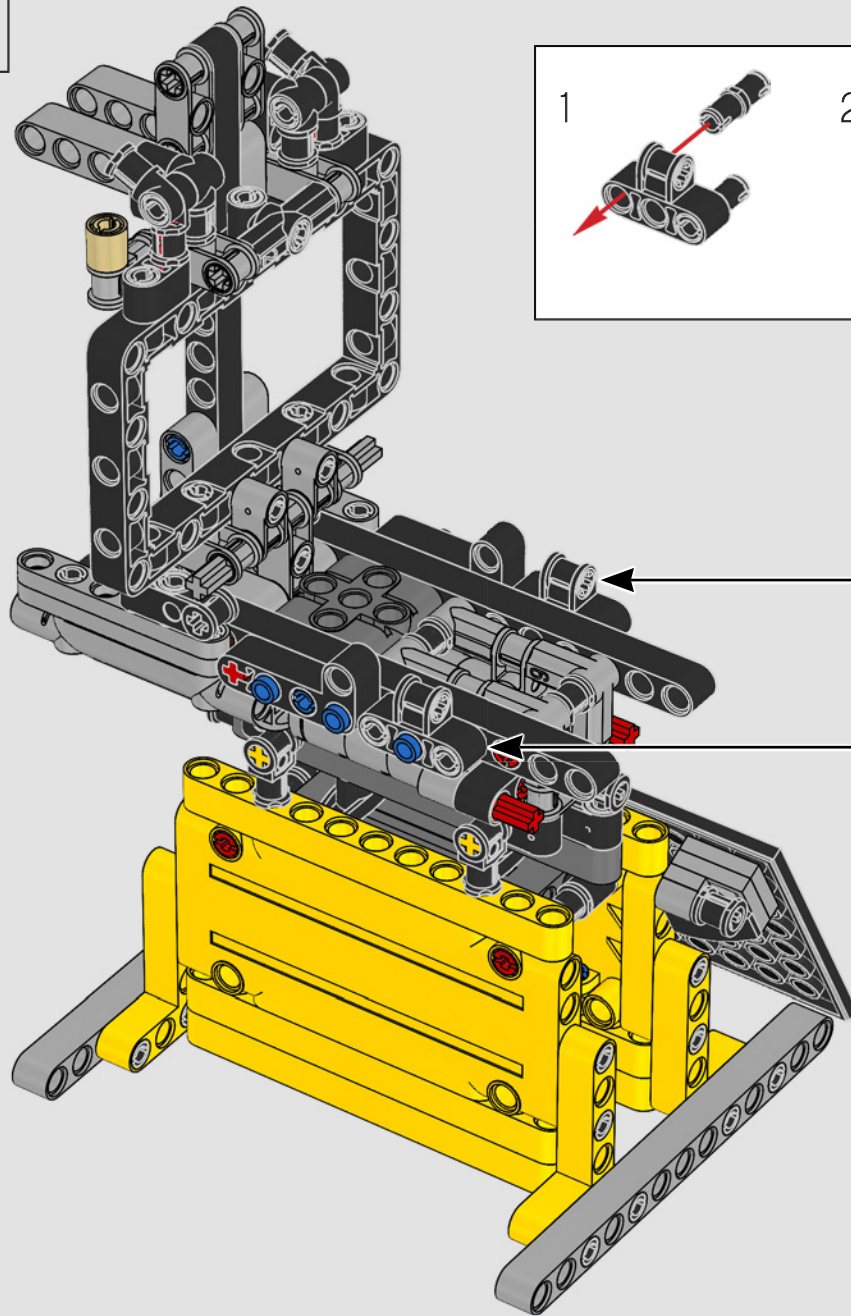

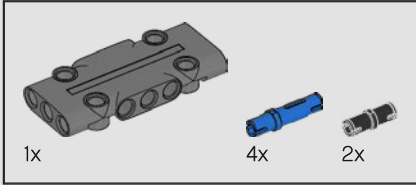
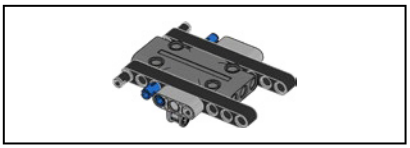

246

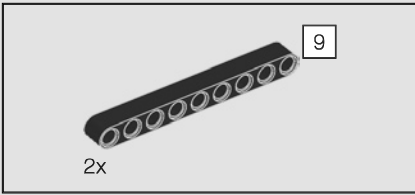
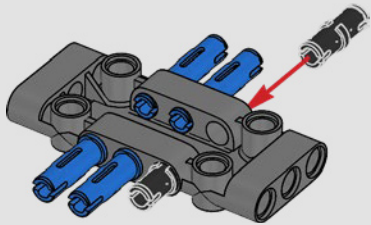

247

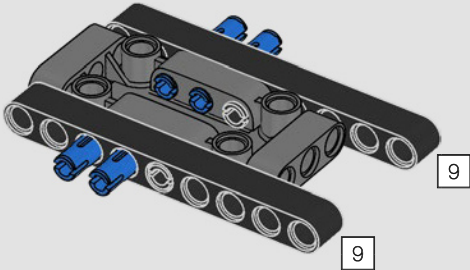

248

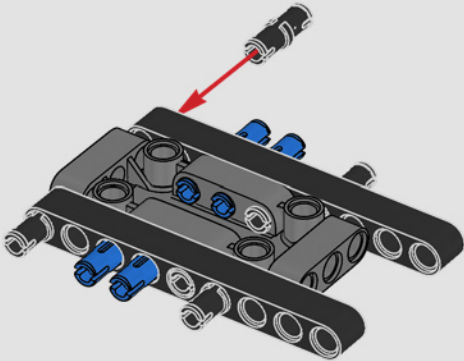

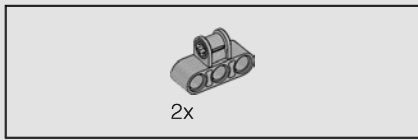

249

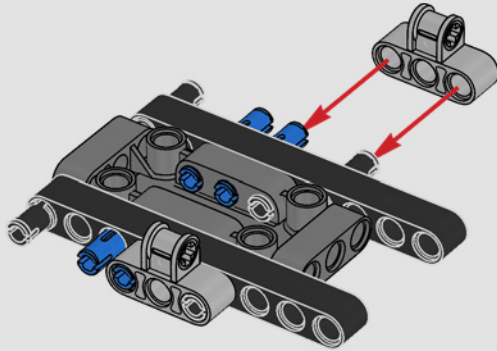

250

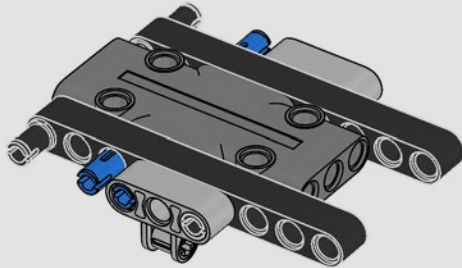

251

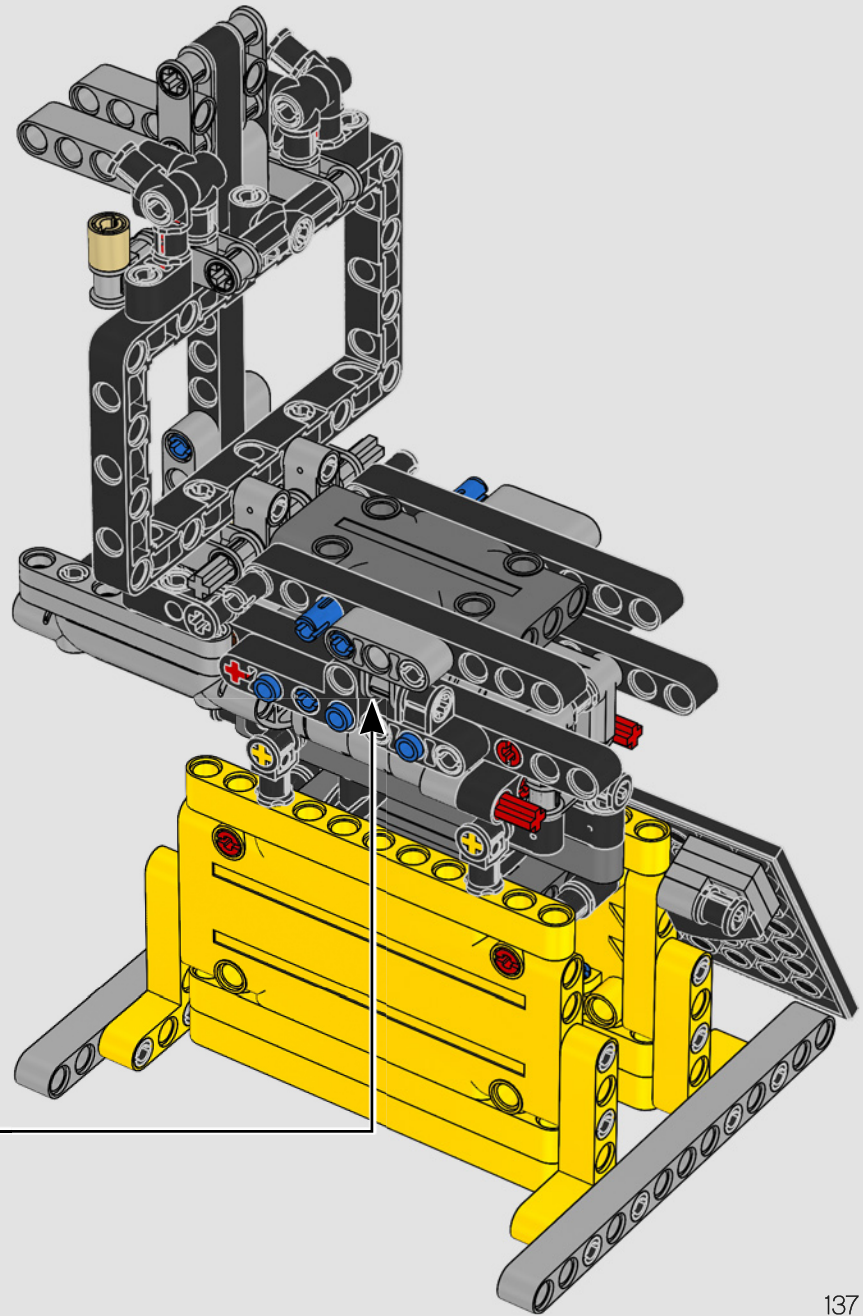

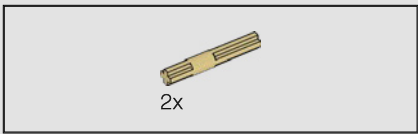

252

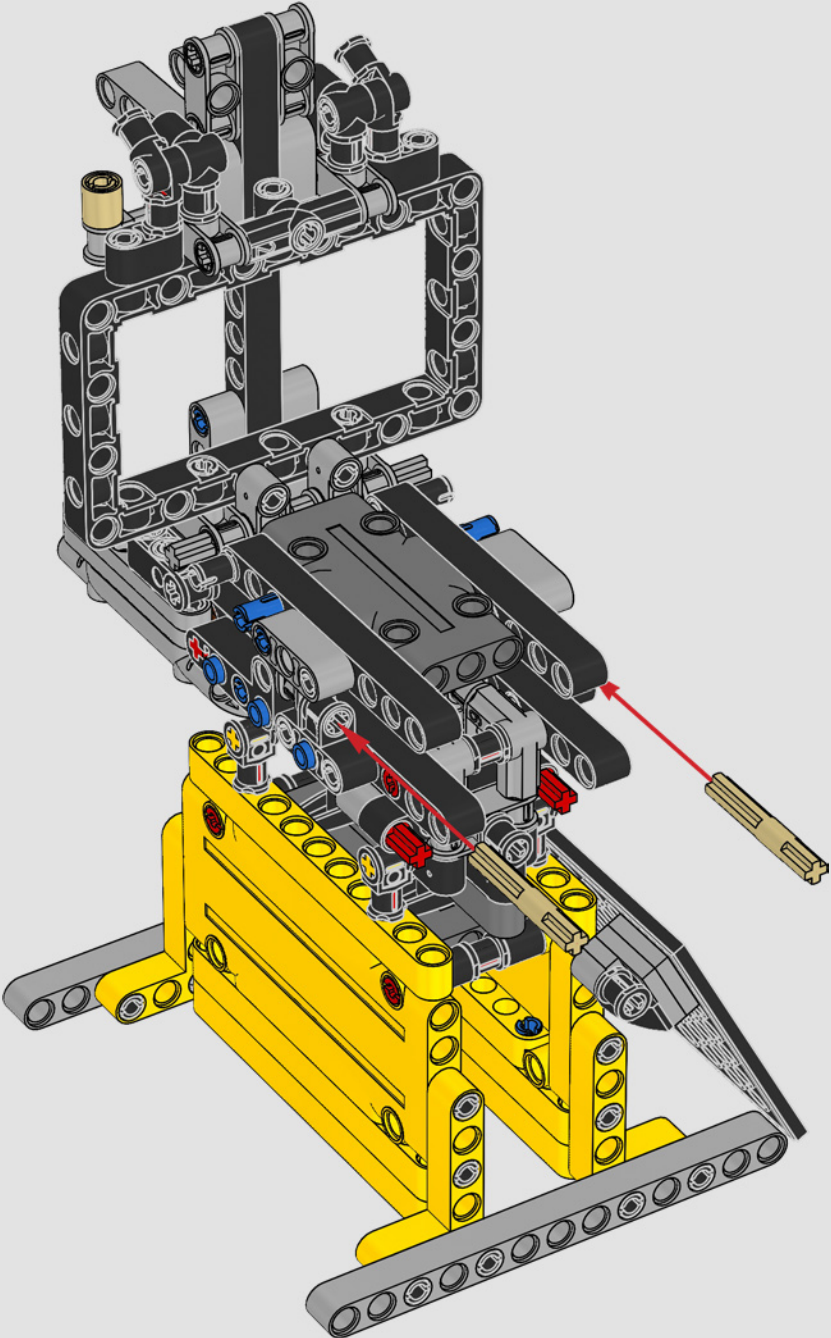

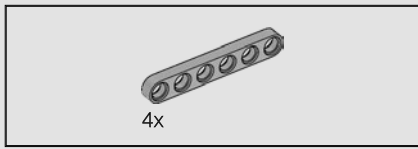

253

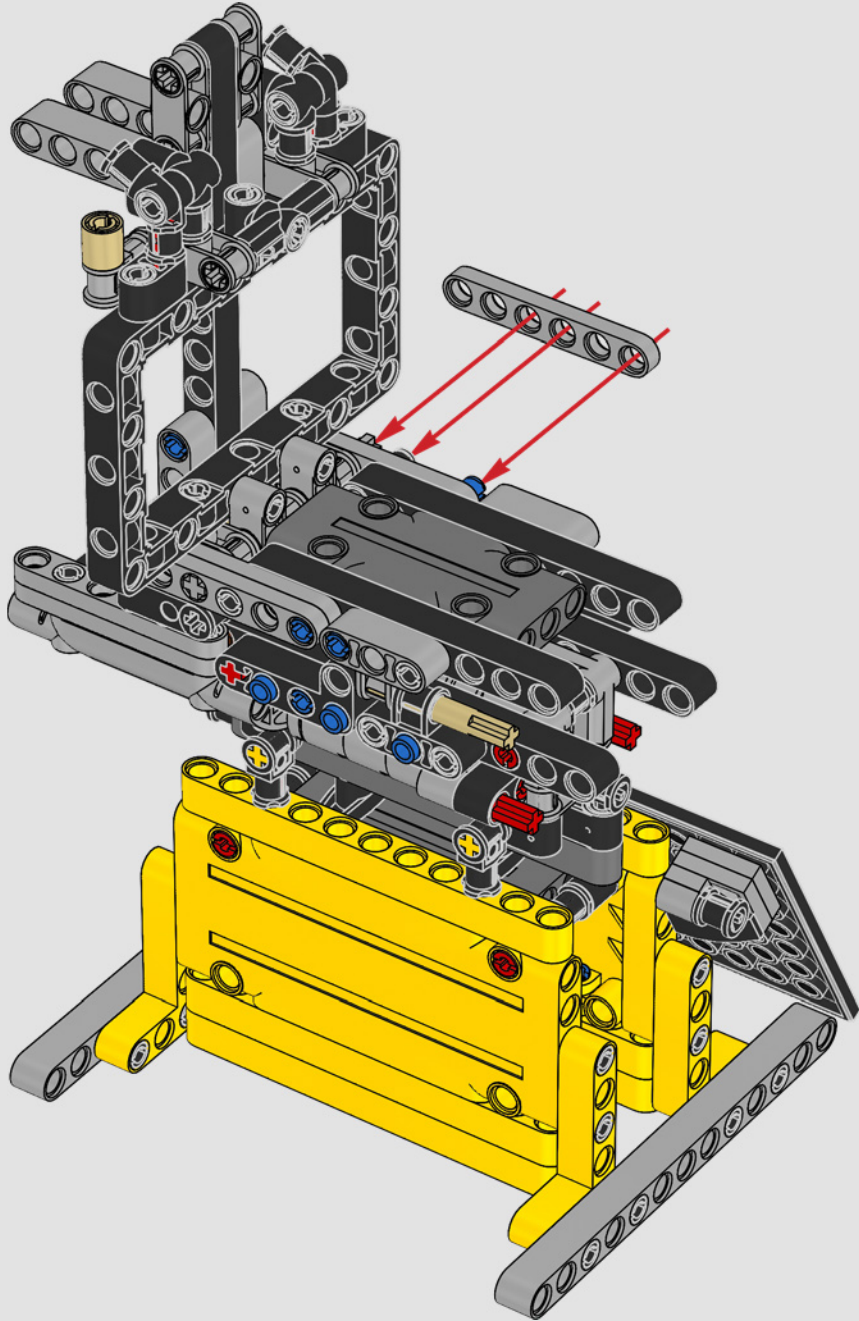

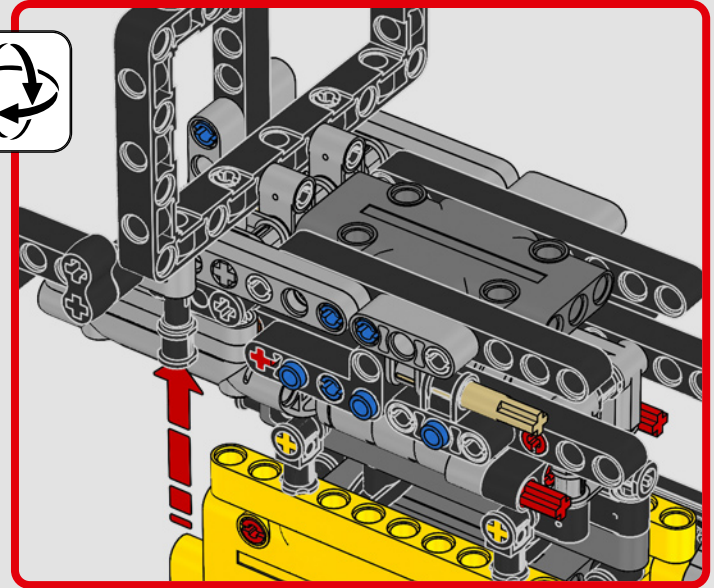
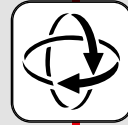
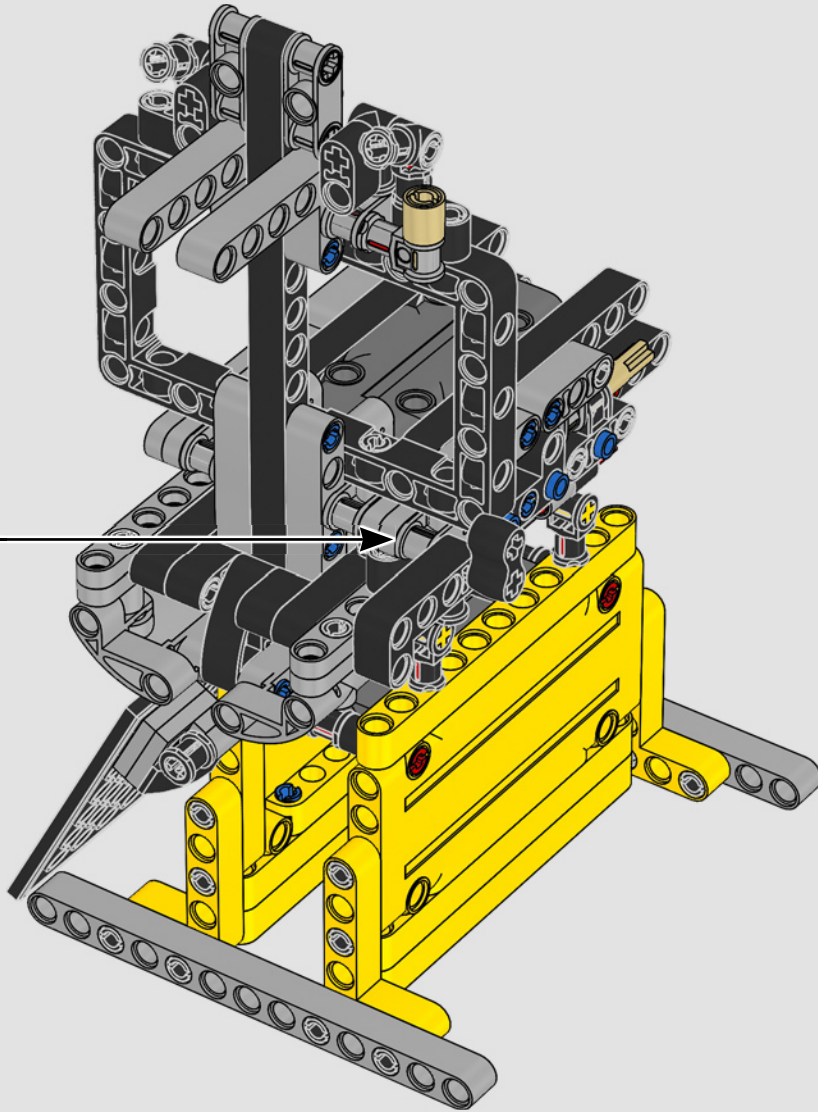

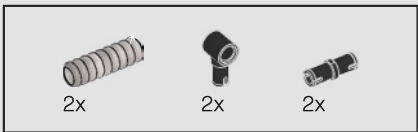

255

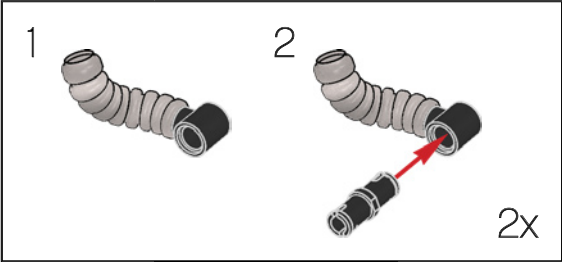
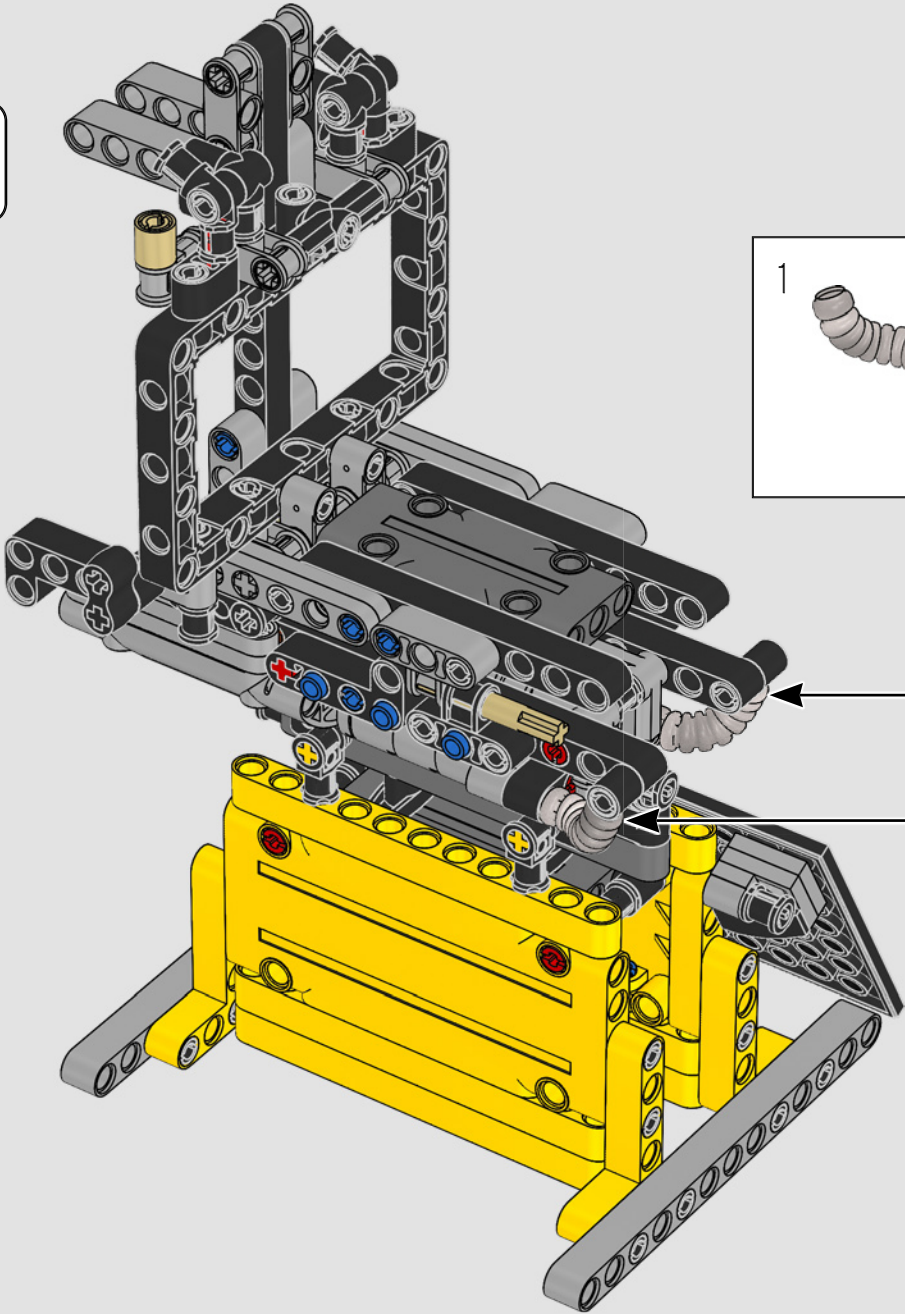

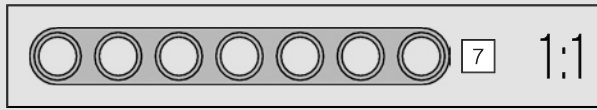
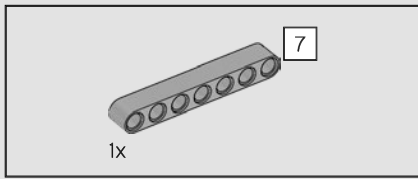

256

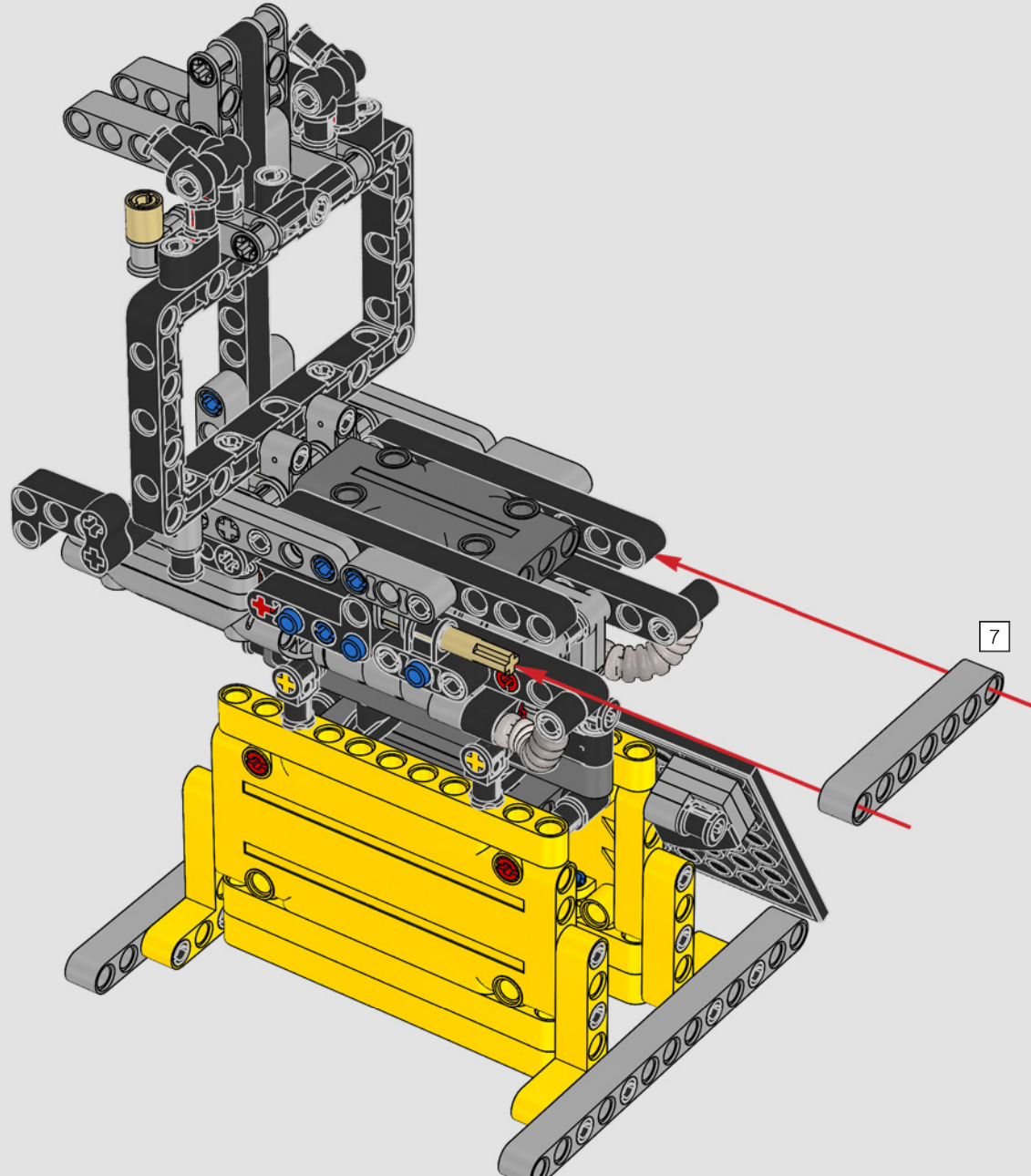

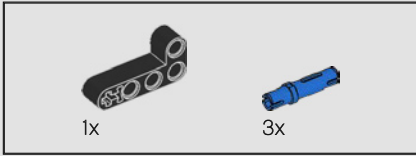
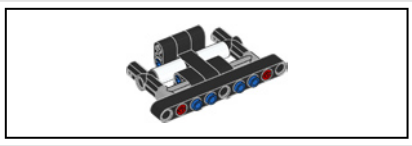

257

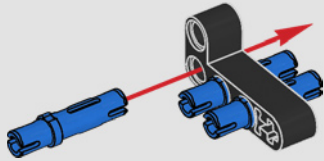

258

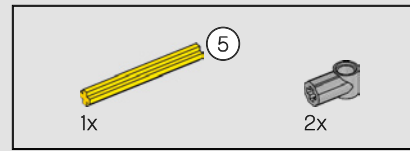
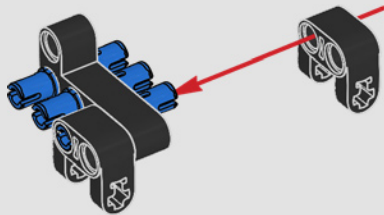

259

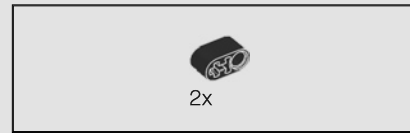
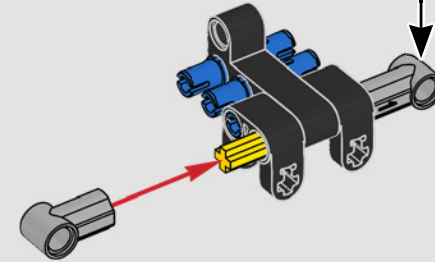
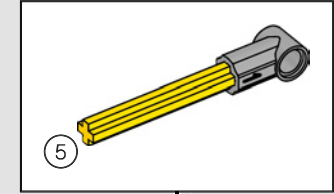

260

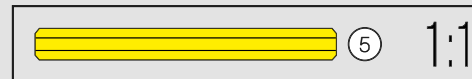
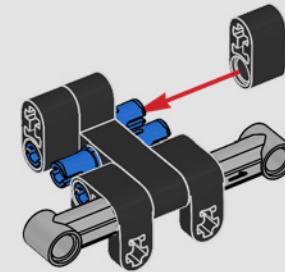

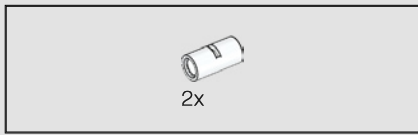

261

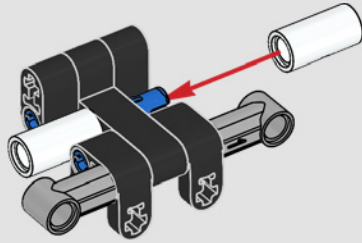

262

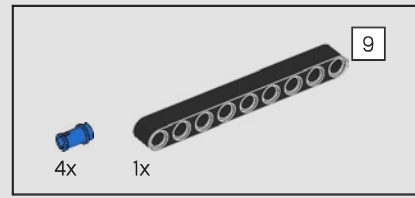
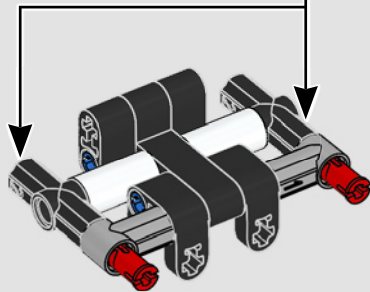
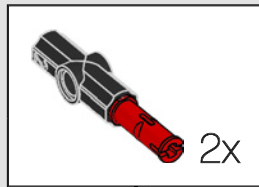

263

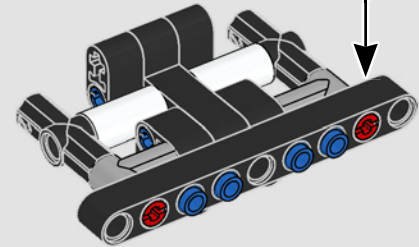
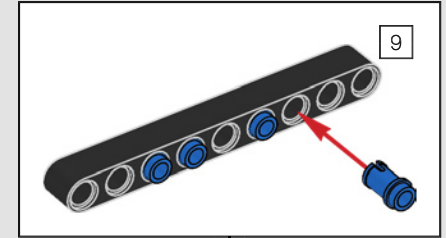

264

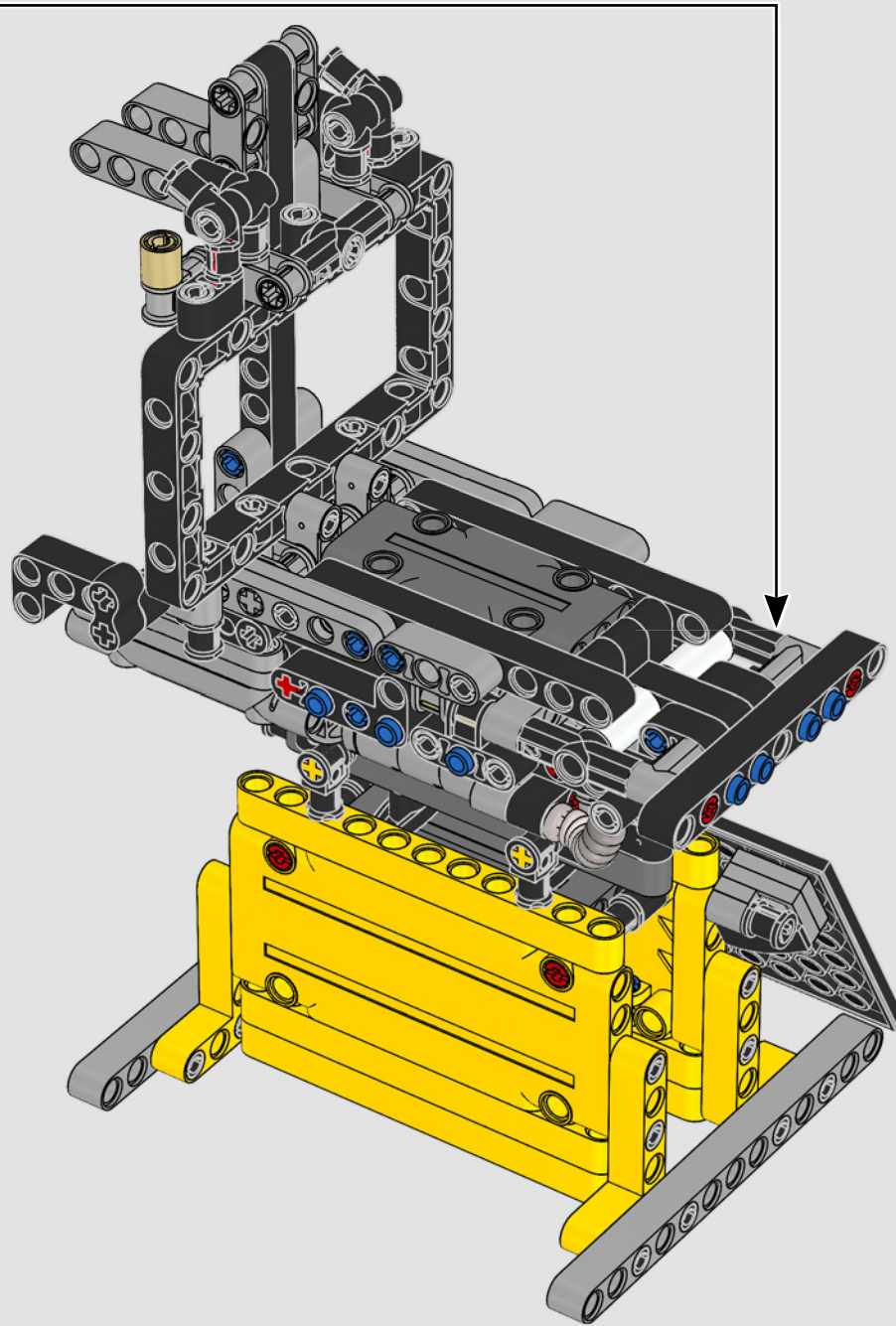

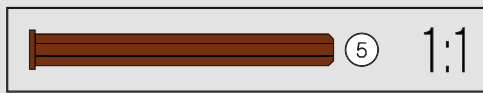
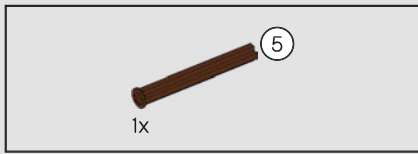

265

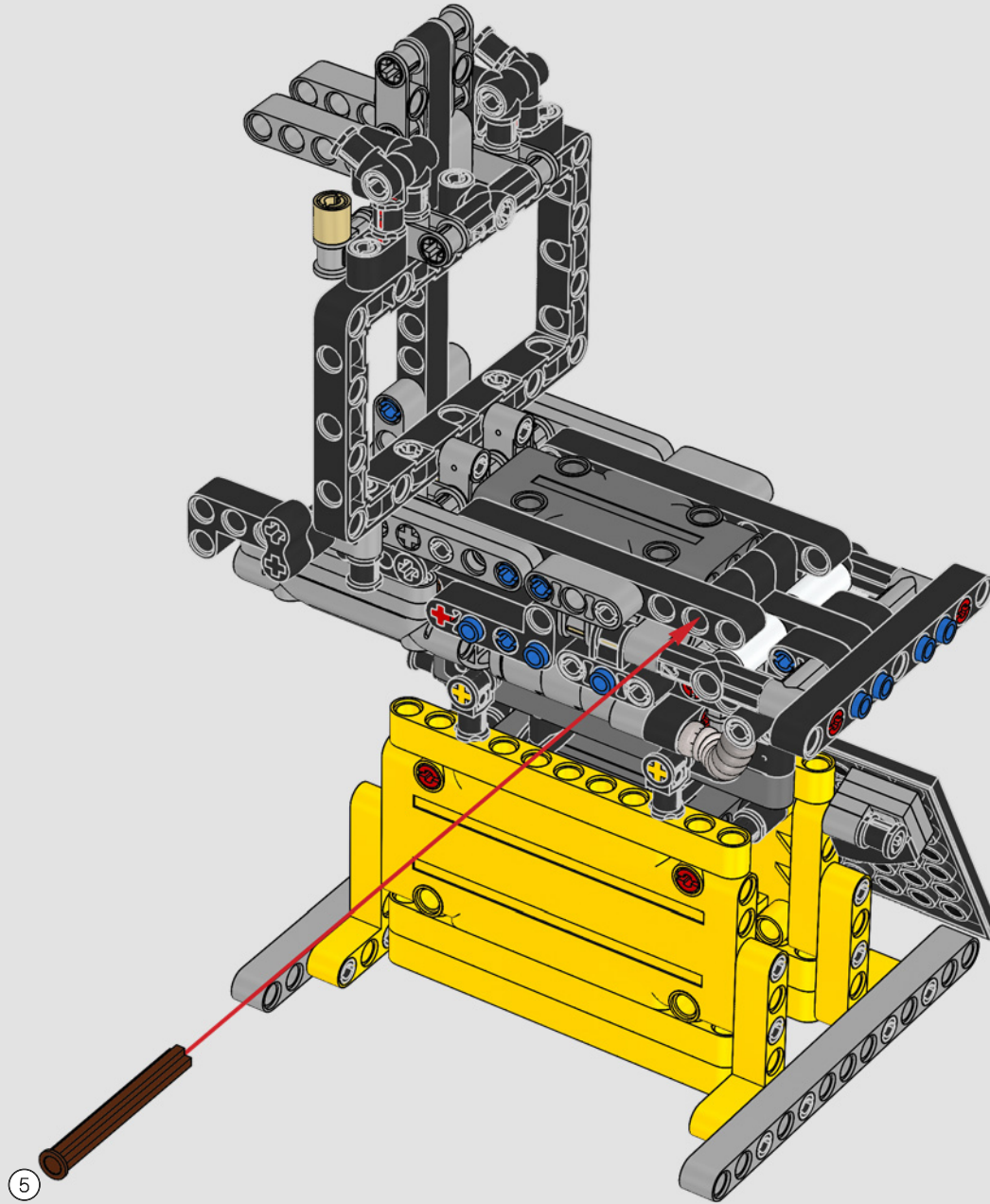

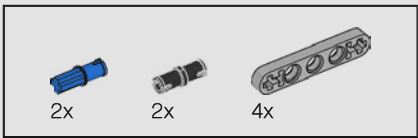

266

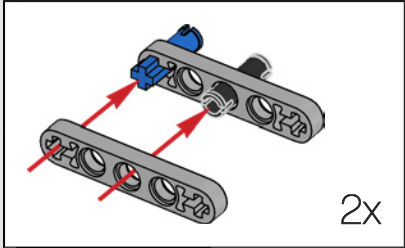
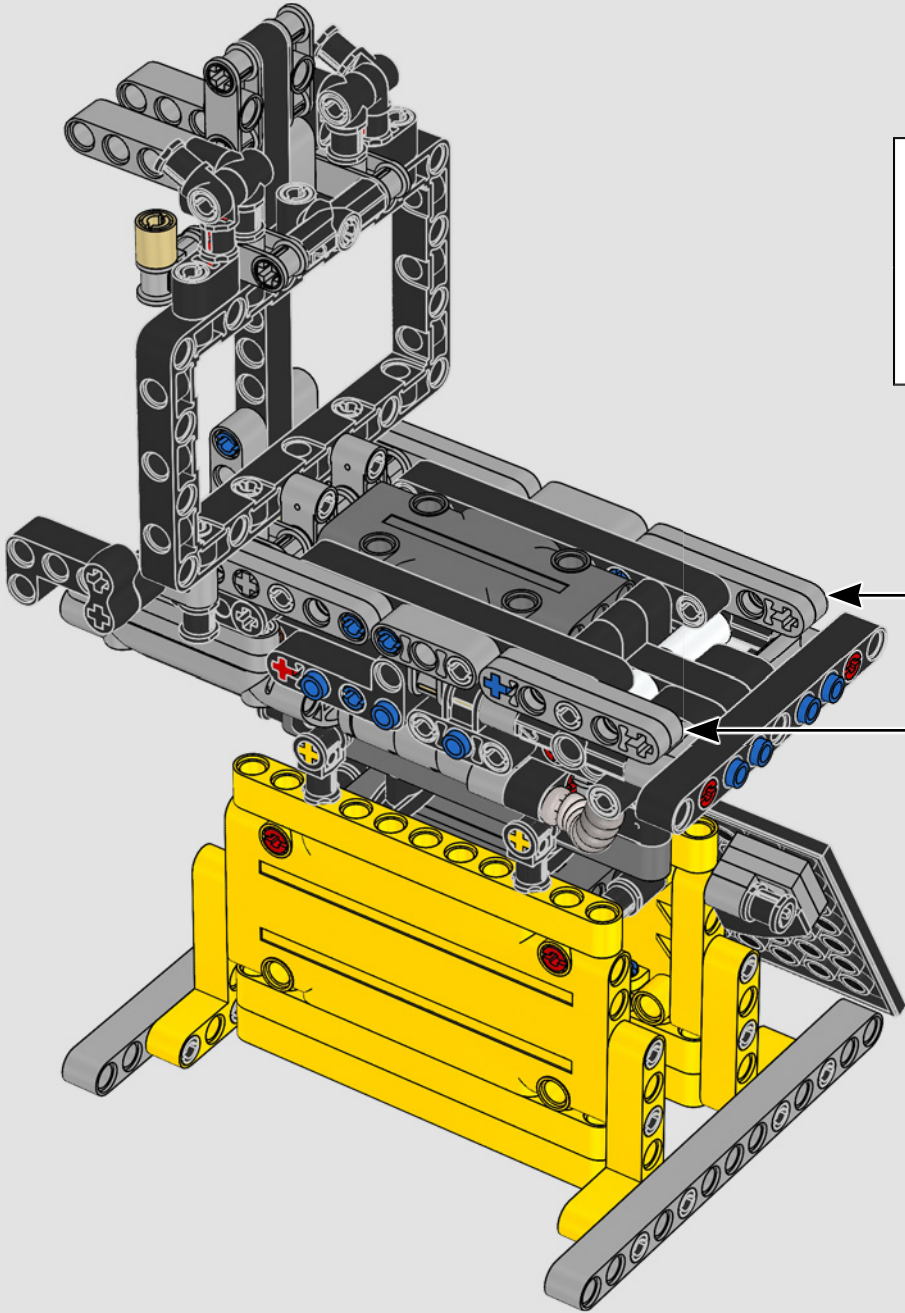

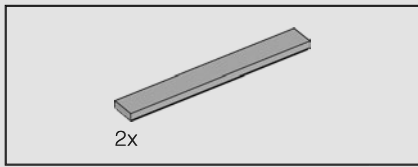

267

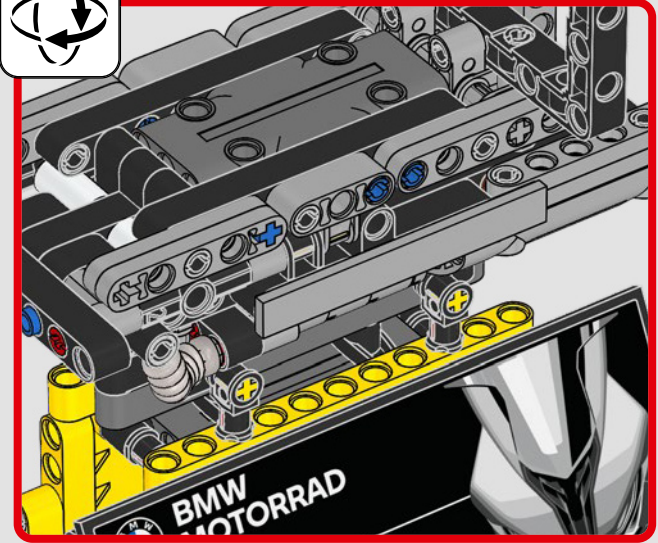
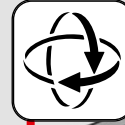
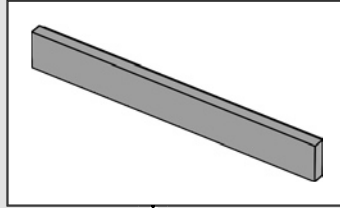
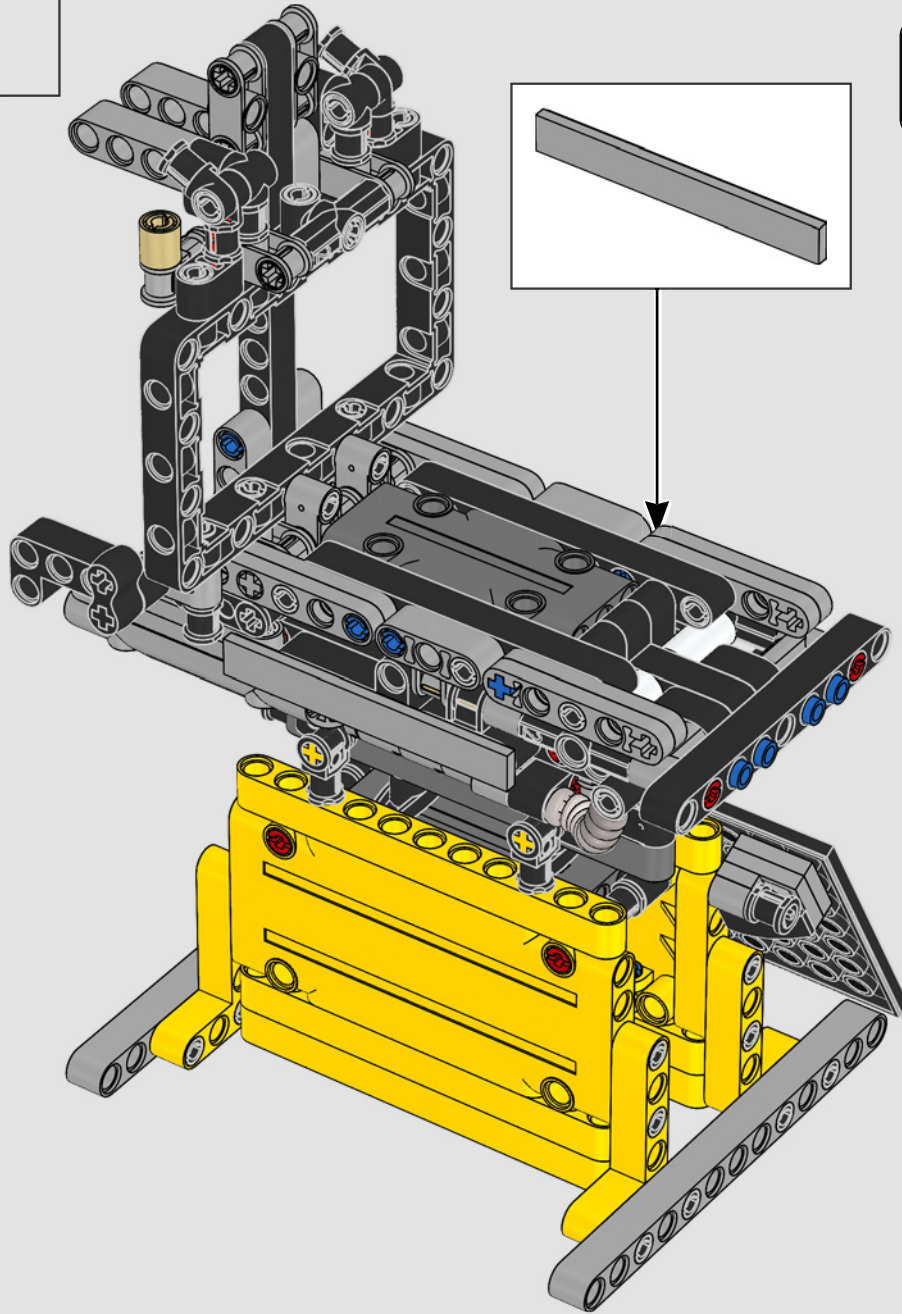

268

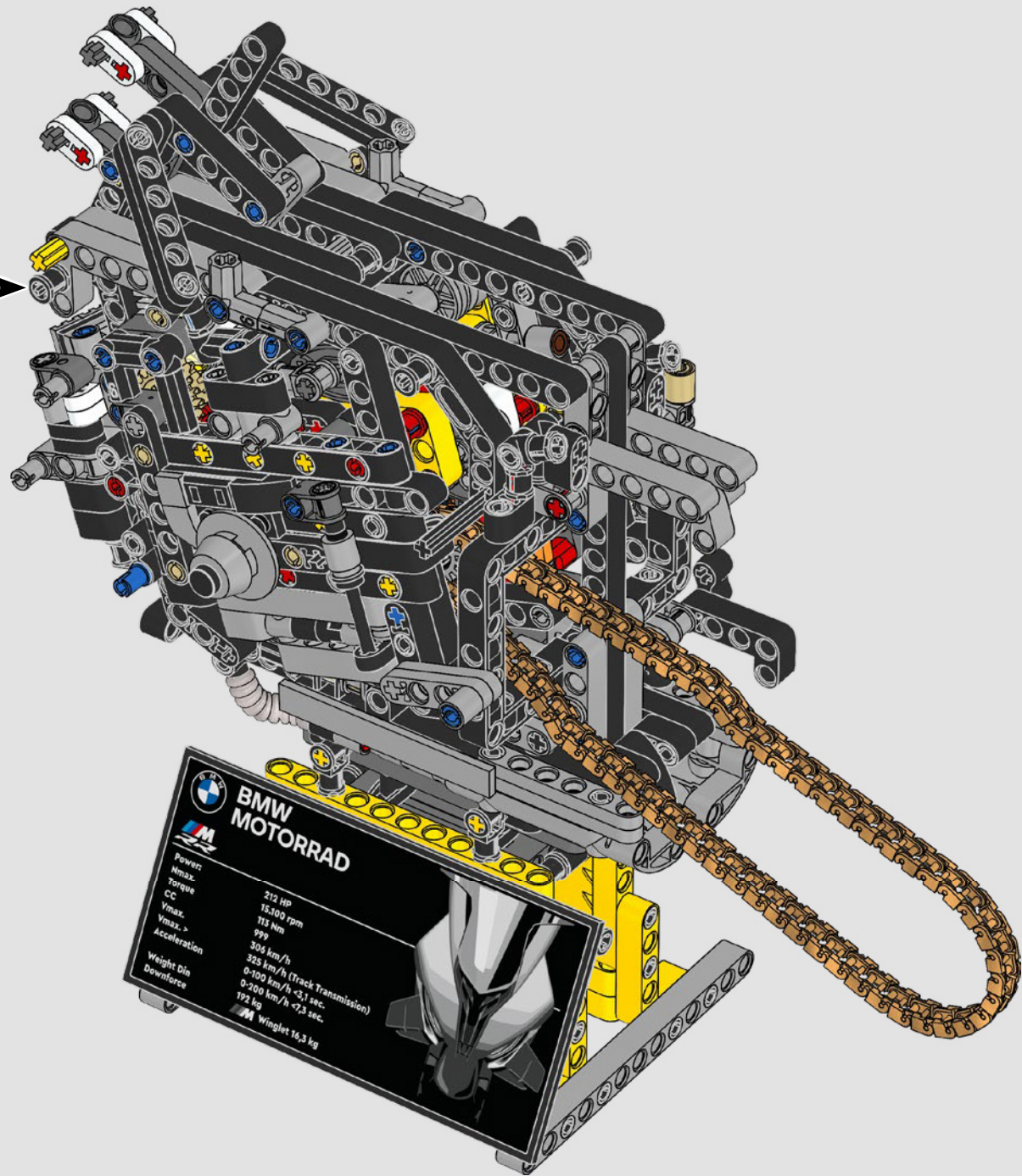

BMW MOTORRAD

Power:	212 HP
Nmax:	15100 rpm
Torque	113 Nm
CC	999
Vmax:	306 km/h
Vmax >	325 km/h (Track Transmission)
Acceleration	0-100 km/h < 3,1 sec.
Weight Din	0-200 km/h < 7,3 sec.
Downforce	192 kg
	Winglet 16,3 kg

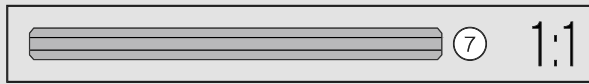
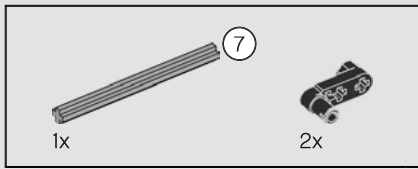

269

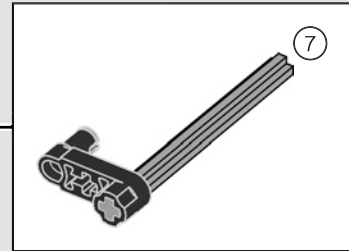
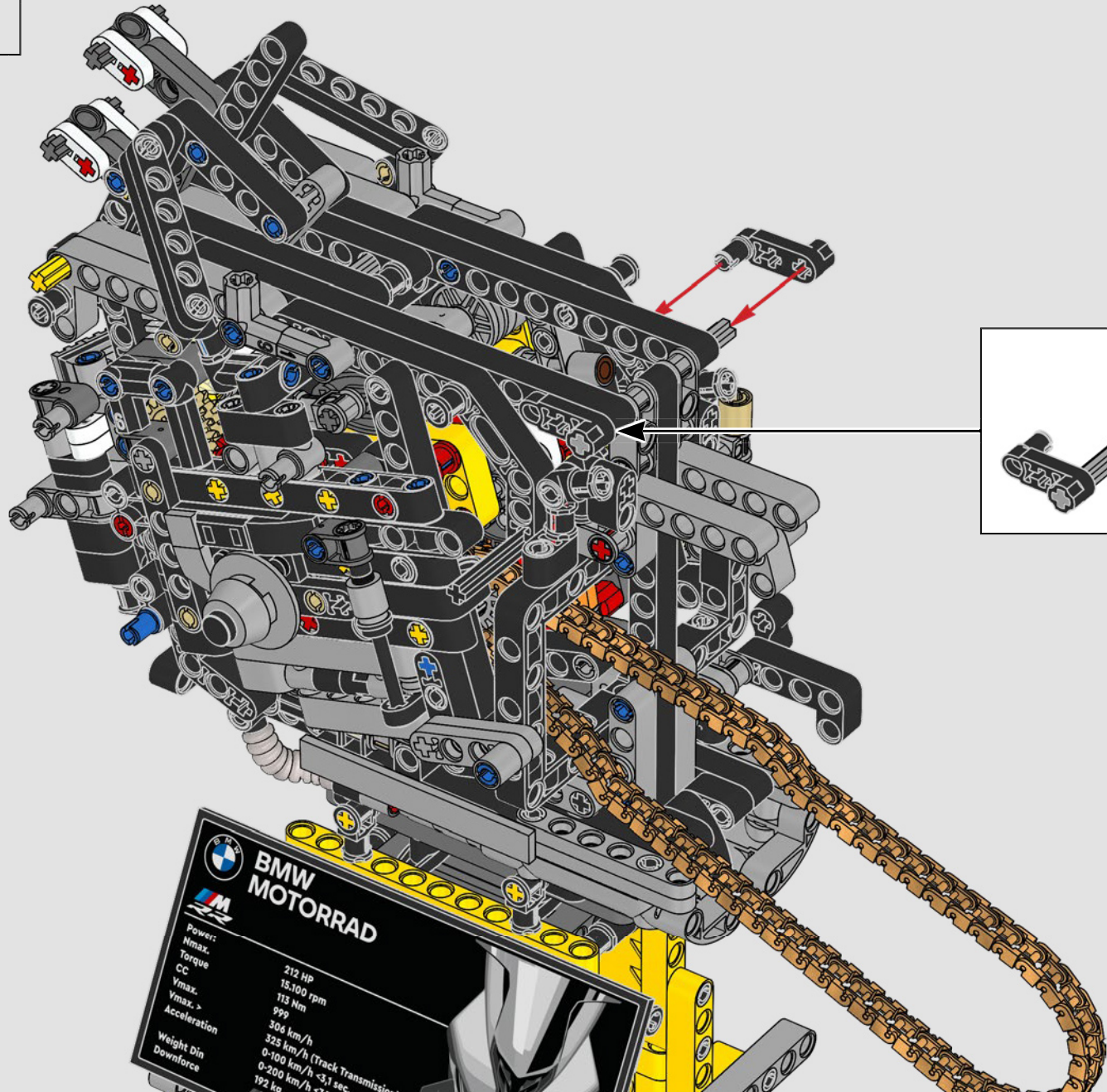

BMW MOTORRAD	
Power:	212 HP
Nmax:	15.100 rpm
Torque:	113 Nm
CC:	999
Vmax:	306 km/h
Vmax. >	325 km/h (Track Transmission)
Acceleration:	0-100 km/h < 3.1 sec
Weight Din:	192 kg
Downforce:	

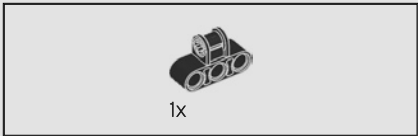

270

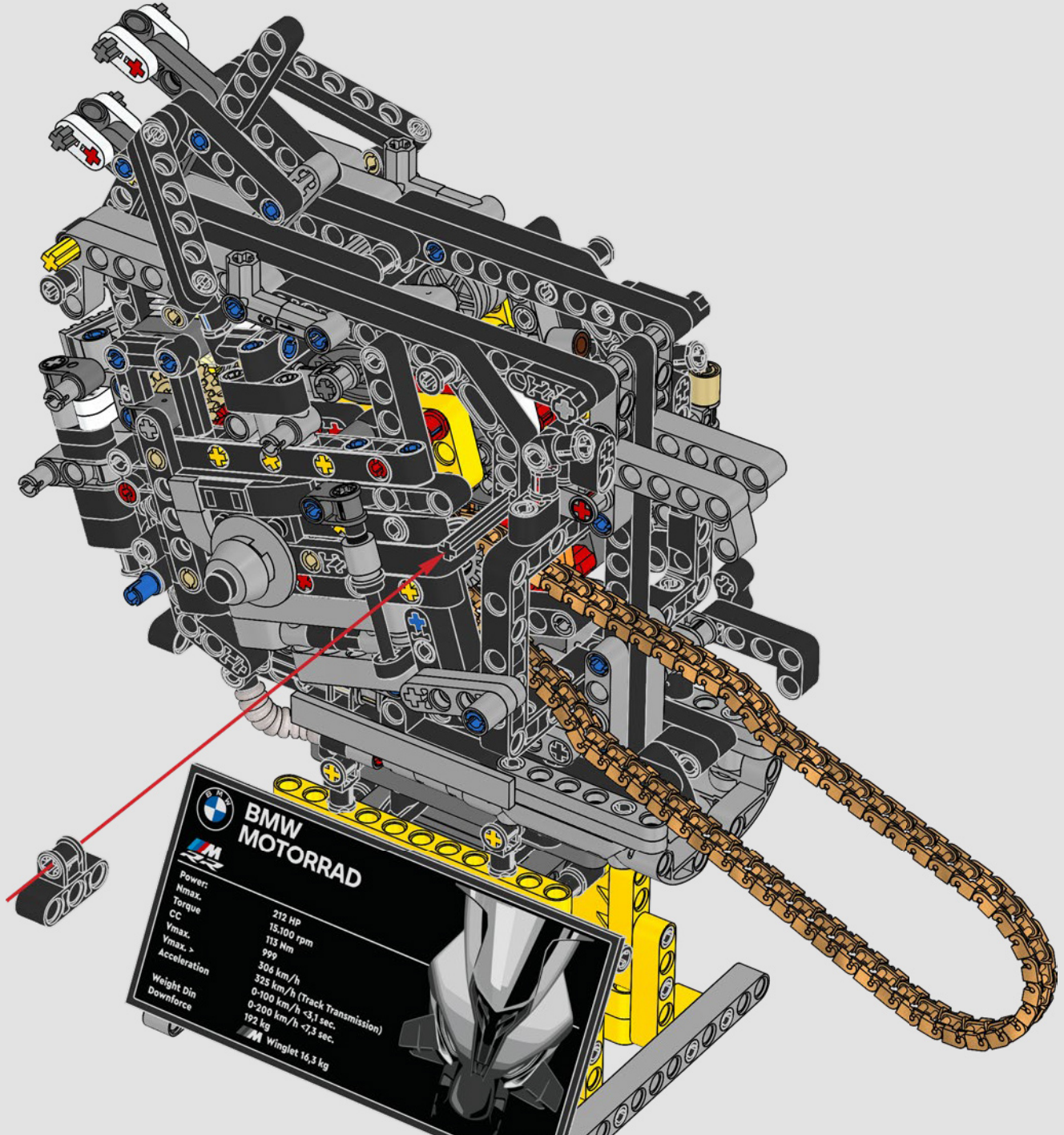

BMW MOTORRAD

Power:	212 HP
Hmax:	15-100 rpm
Torque	113 Nm
CC	999
Vmax:	306 km/h
Vmax. >	326 km/h (Track Transmission)
Acceleration	0-100 km/h <3,1 sec.
Weight Din	0-200 km/h <7,3 sec.
Downforce	192 kg
	Winglet 16,3 kg

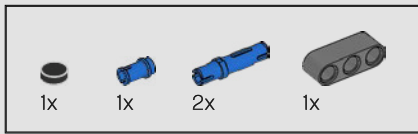

271

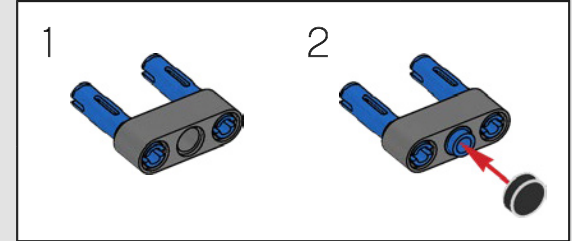
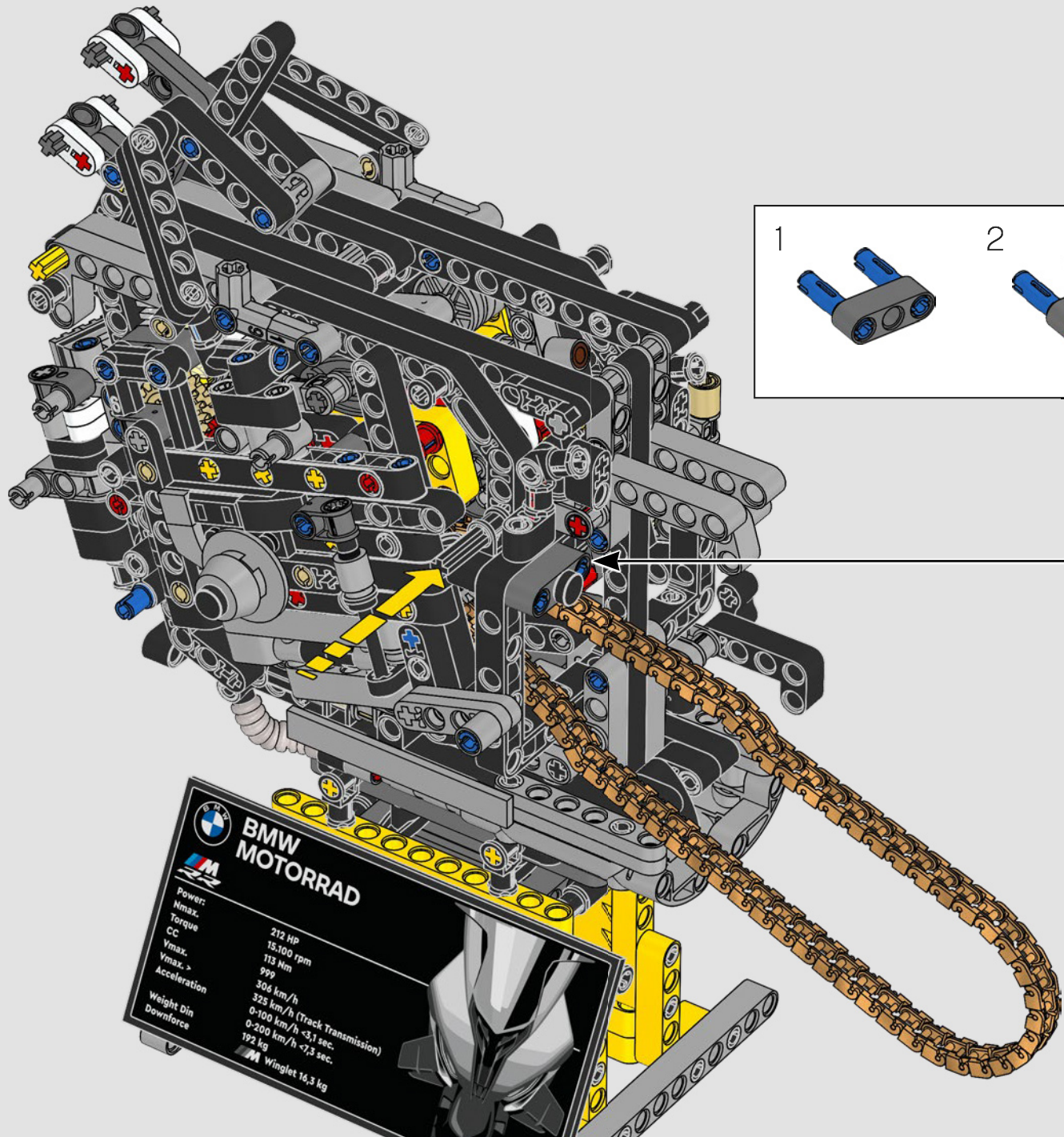

BMW MOTORRAD

Power:	212 HP
Nmax:	15.100 rpm
Torque	113 Nm
CC	999
Vmax:	306 km/h
Vmax >	325 km/h (Track Transmission)
Acceleration	0-100 km/h < 3,1 sec.
	0-200 km/h < 7,3 sec.
Weight Din	192 kg
Downforce	Winglet 16,3 kg



272

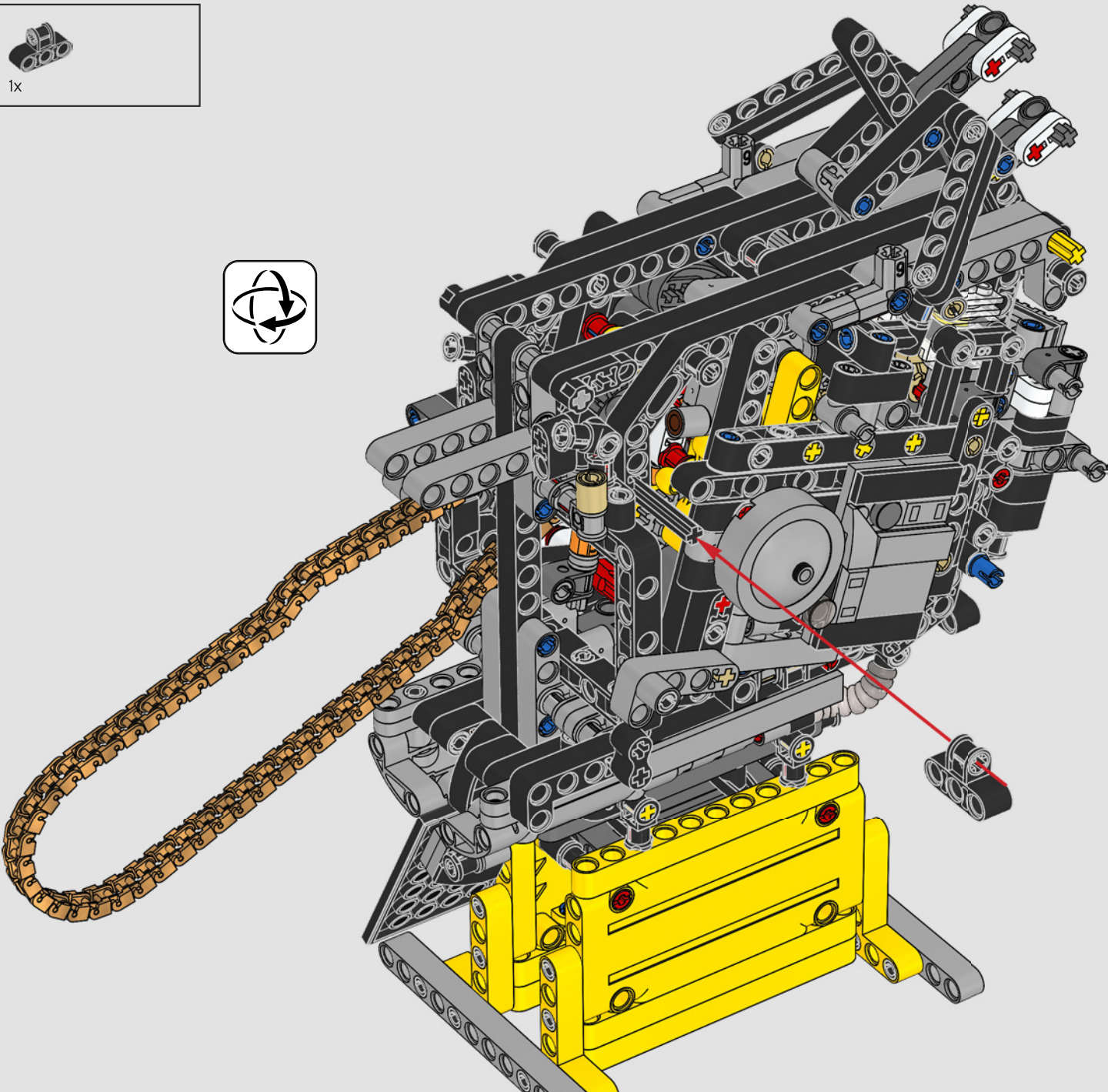

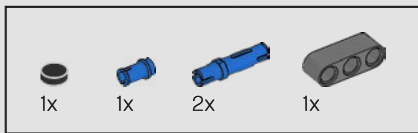

273

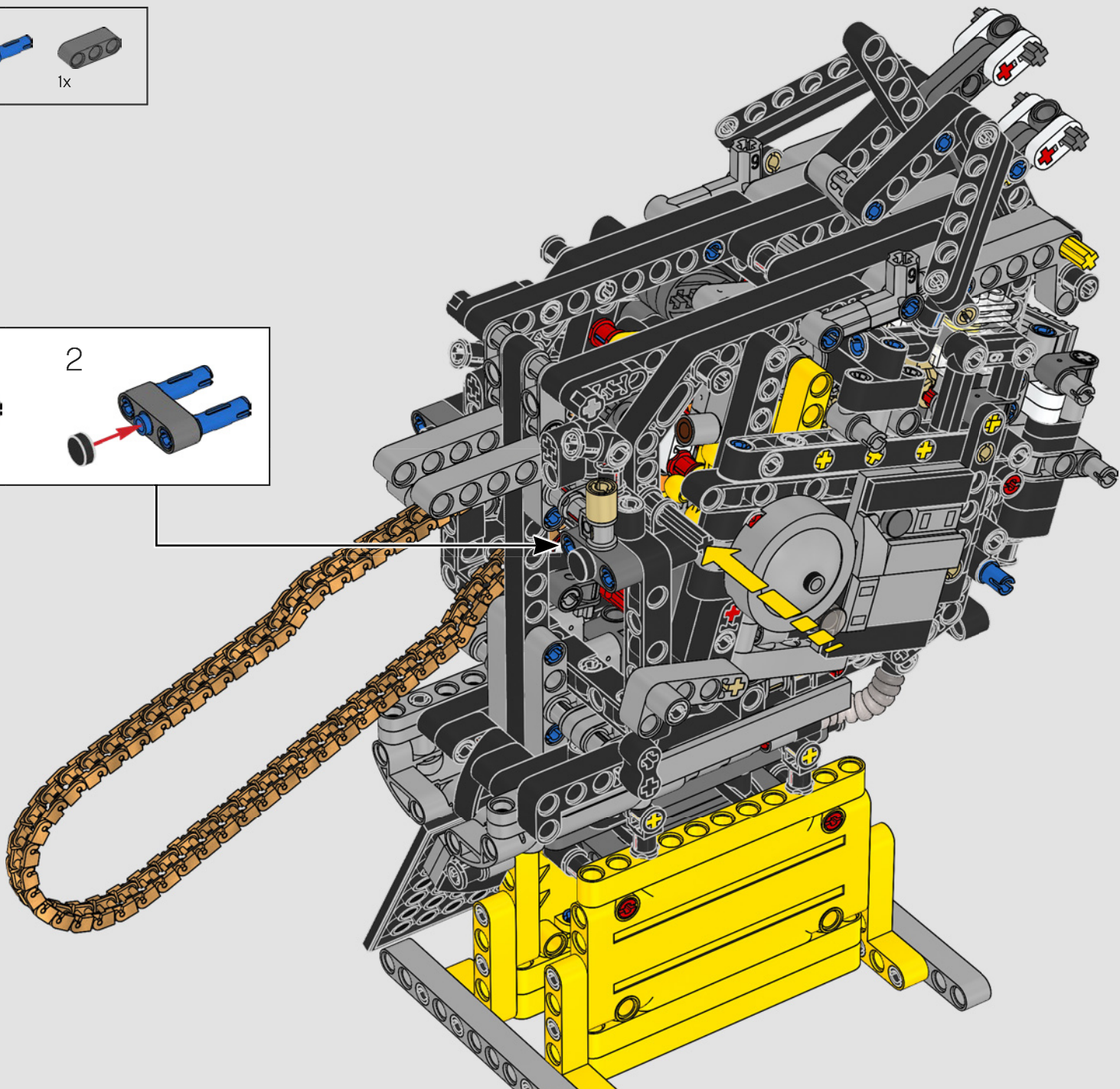
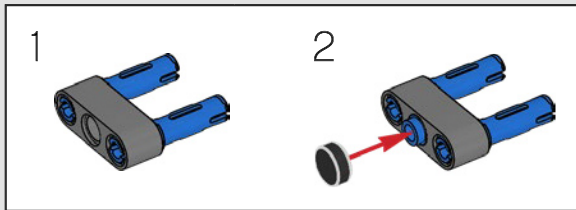

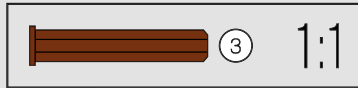
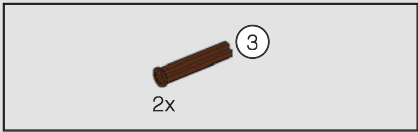

274

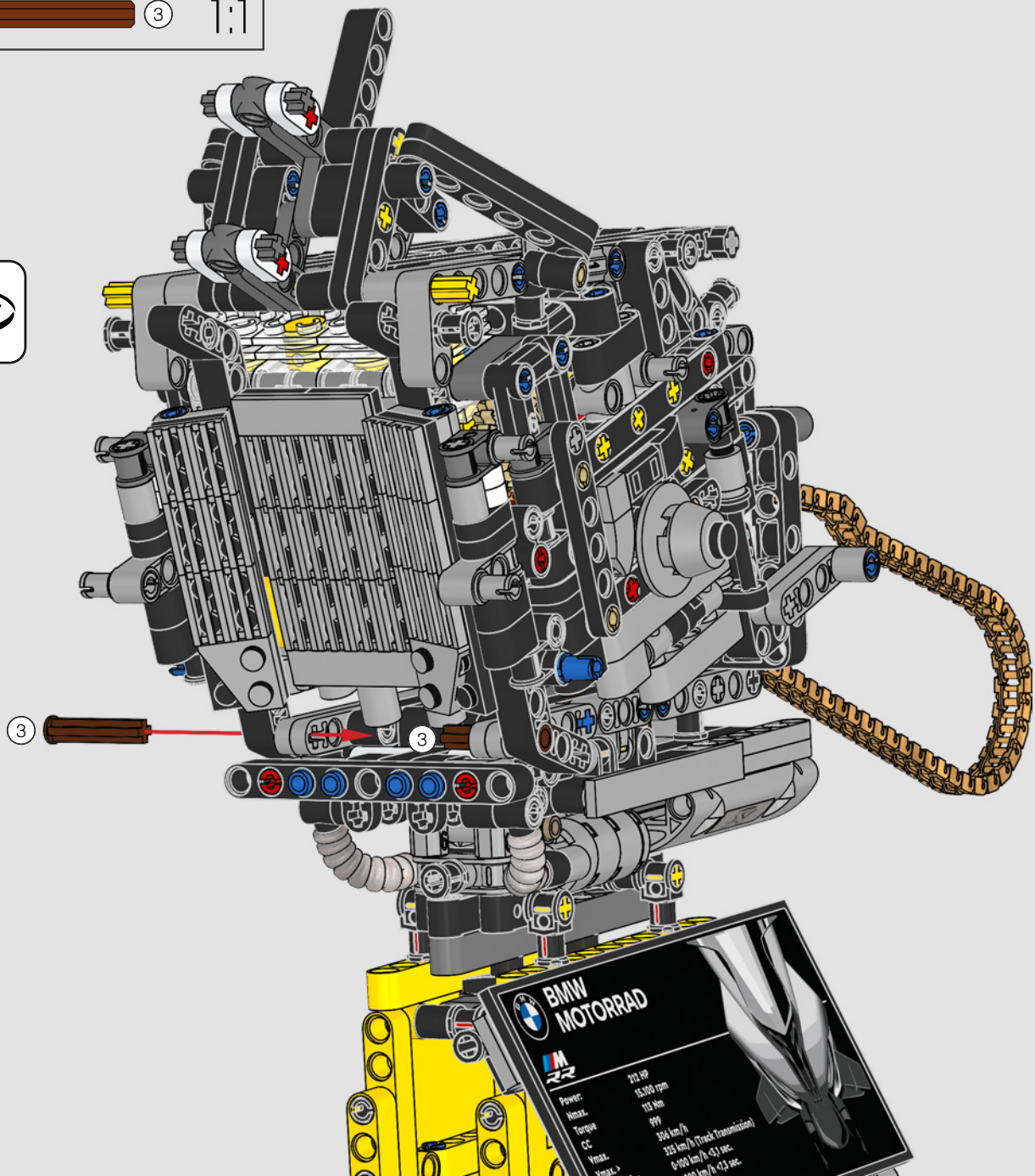

BMW MOTORRAD

RR

Power: 211 HP
15,100 rpm
Max. Torque: 999
304 km/h
CC: 306 km/h (Track Transmission)
0-100 km/h: 4.1 sec.
Max. > 200 km/h: 0.2 sec.



2x



3x



2x

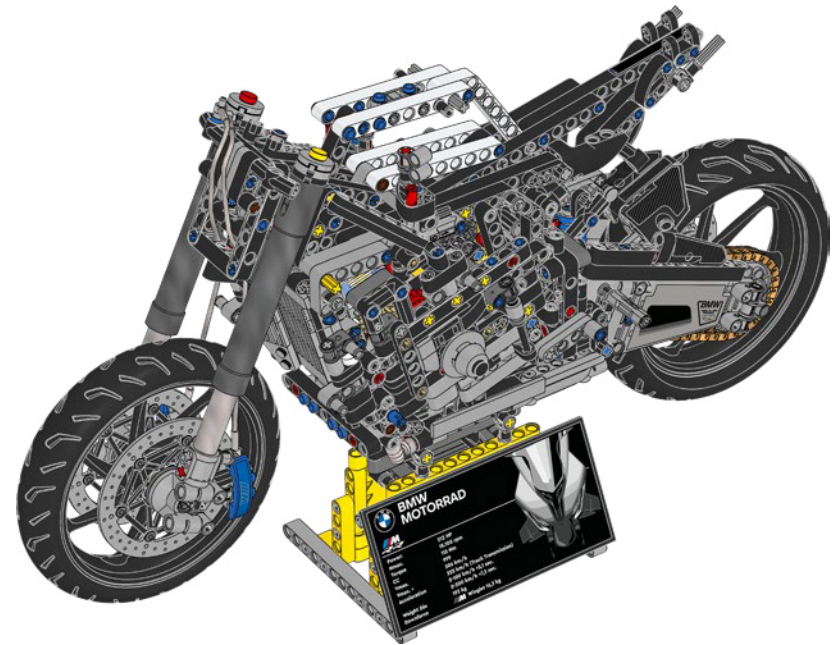
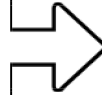



2x

275



2x

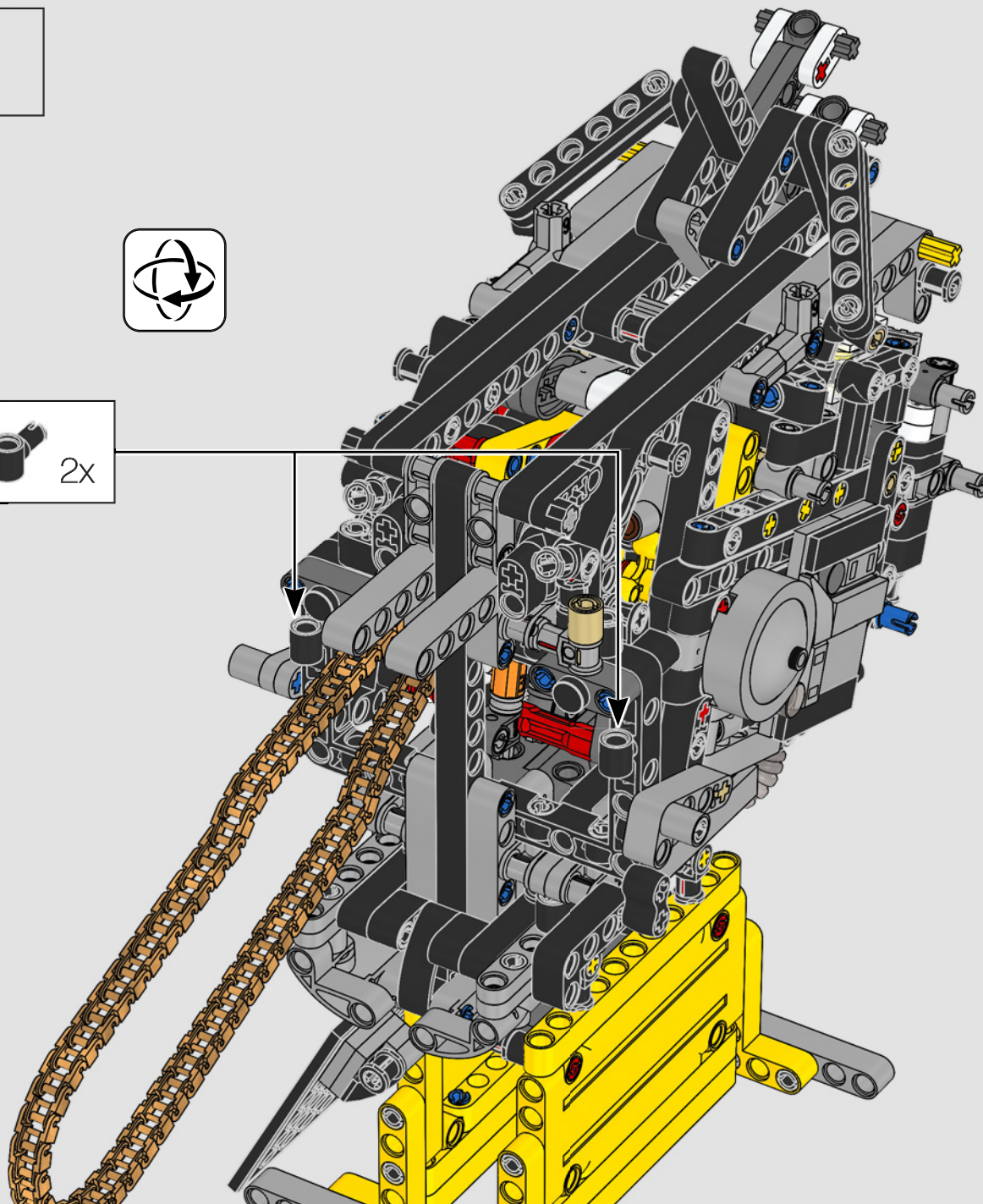

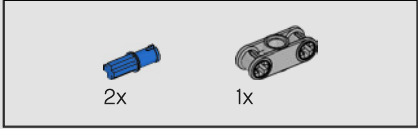
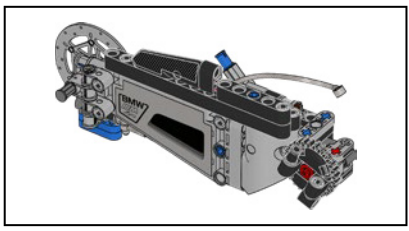

276

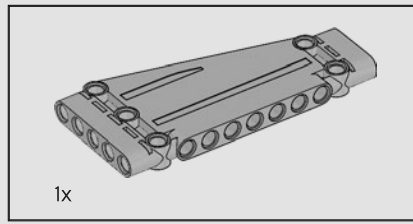
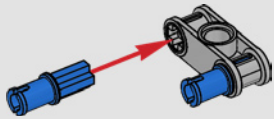

277

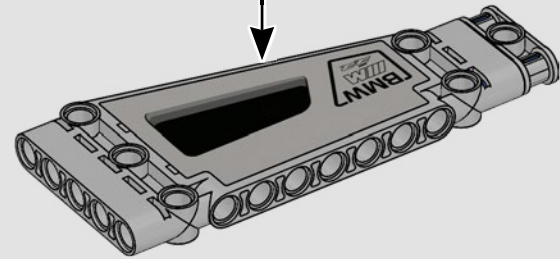
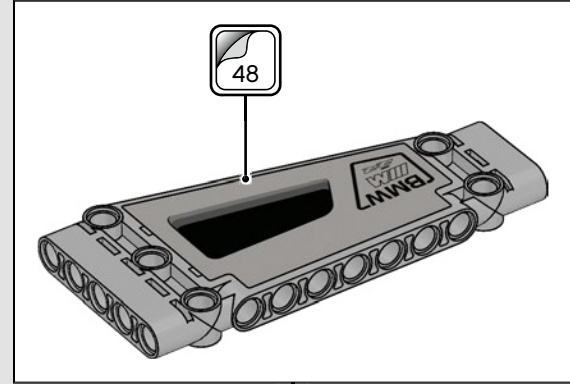

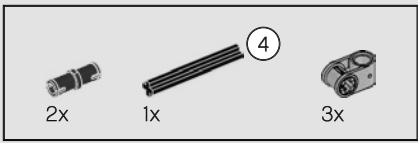

278

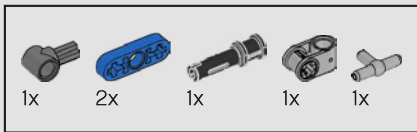
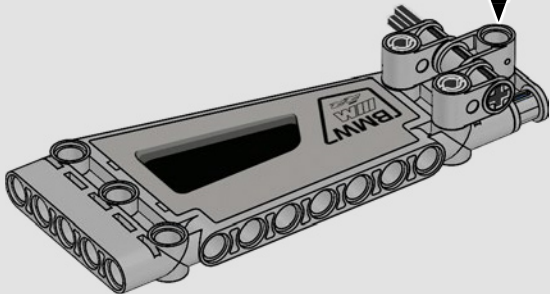
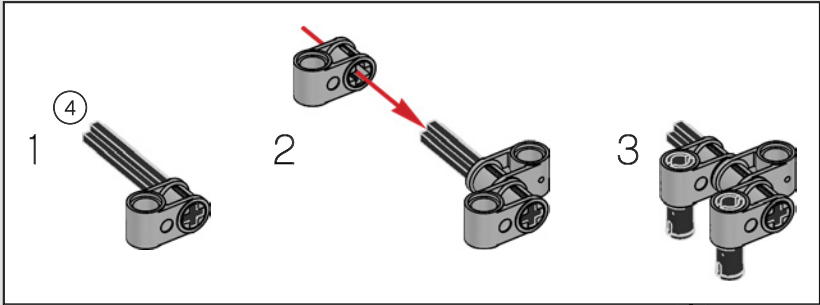

279

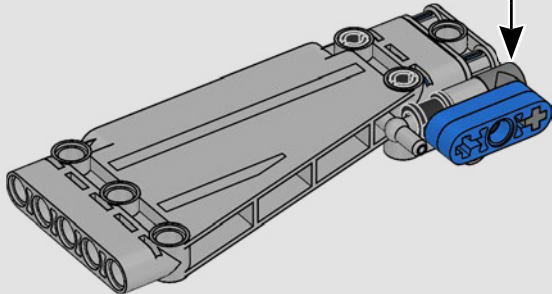
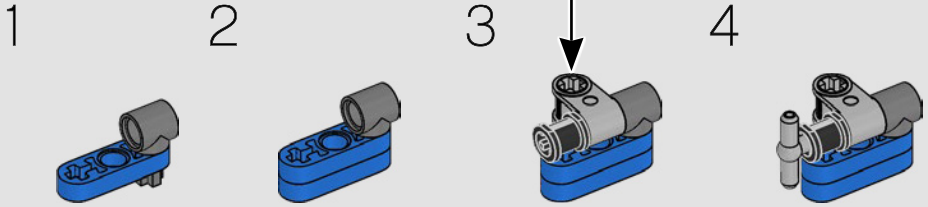
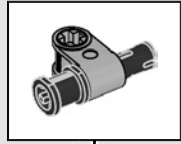

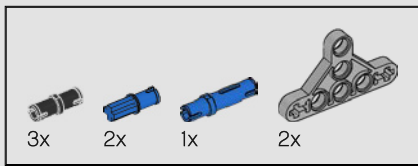

280

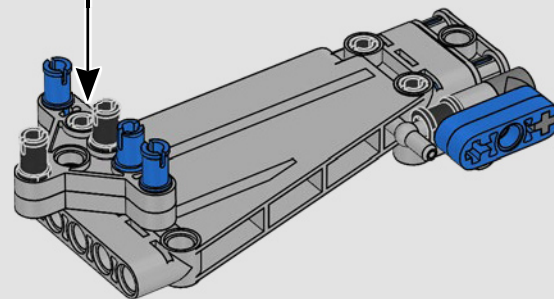
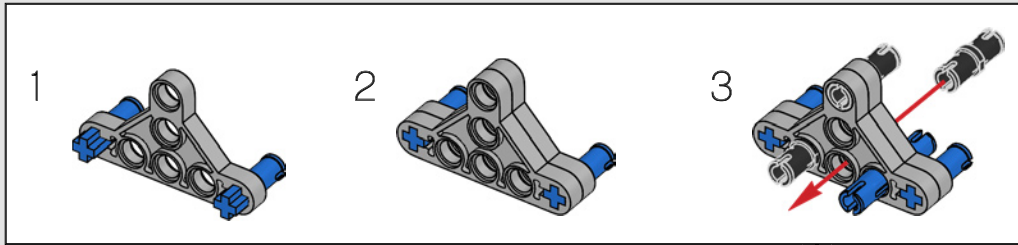

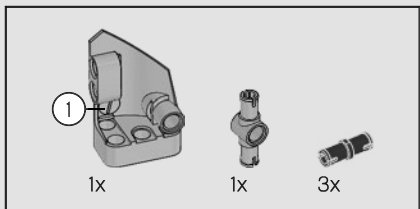

281

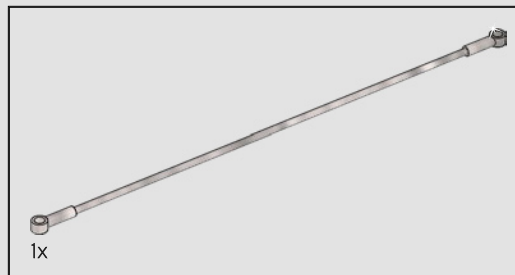
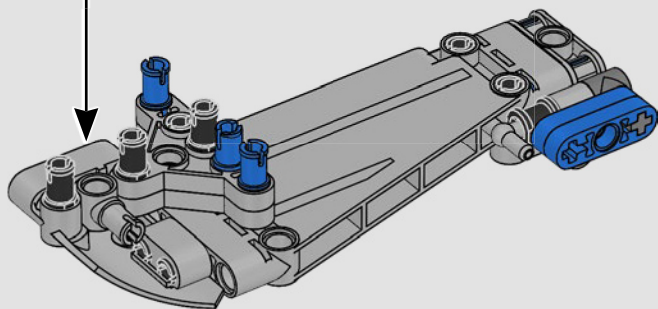
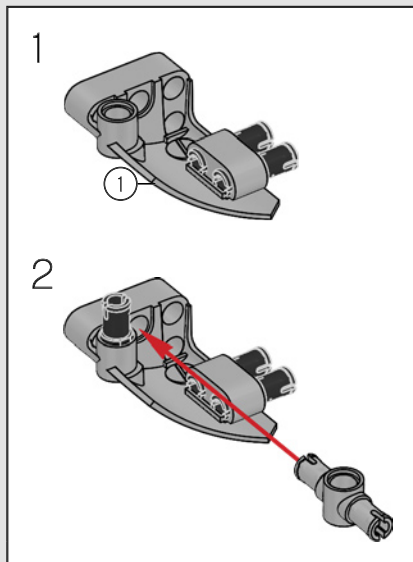

282

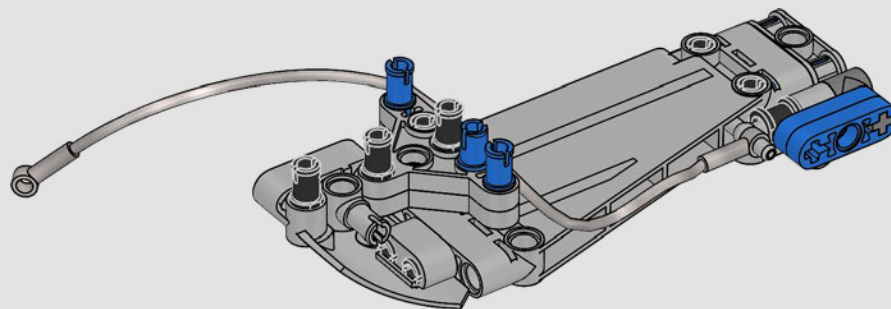

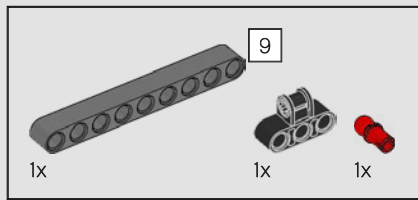

283

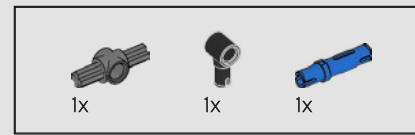
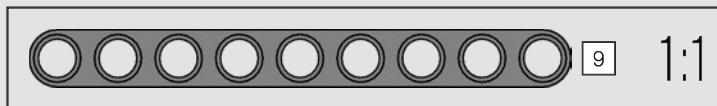
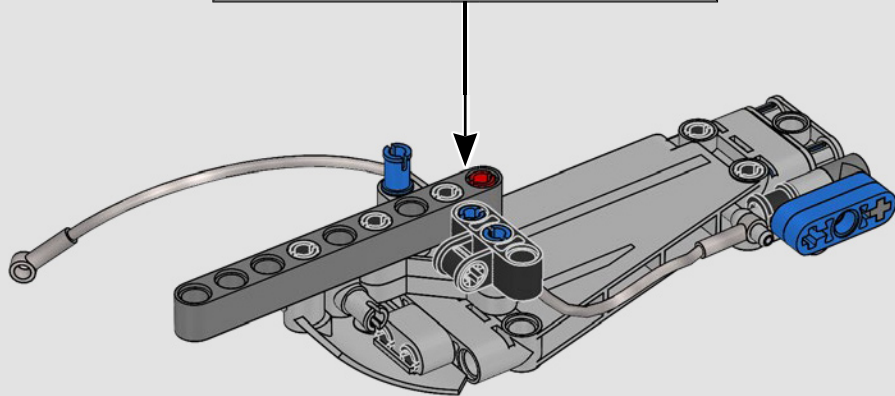
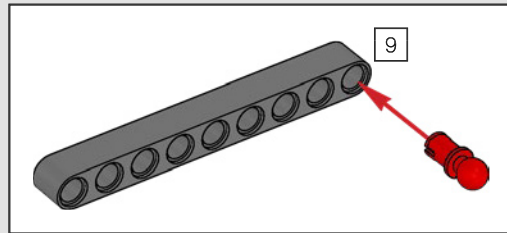
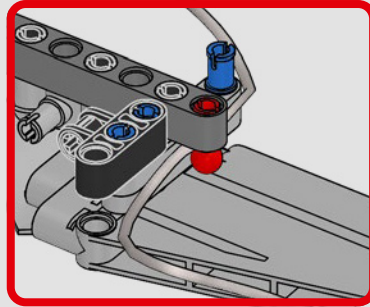

284

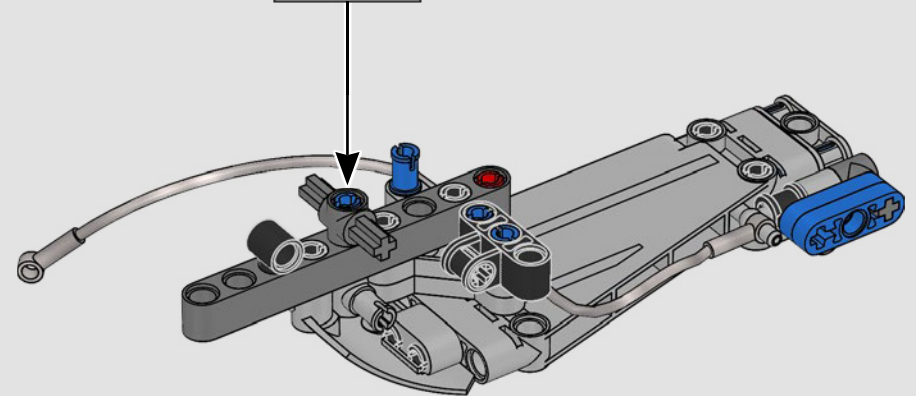
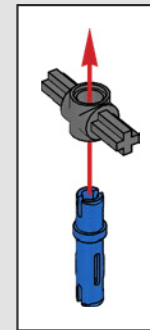

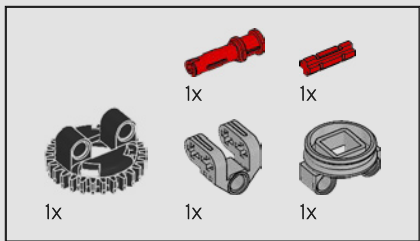

285

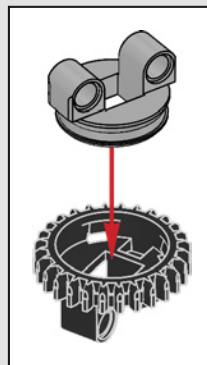

1

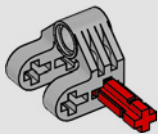

2

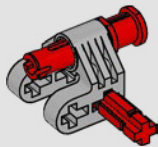

3

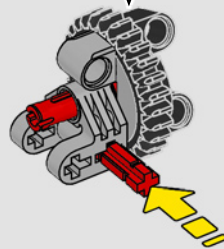

4

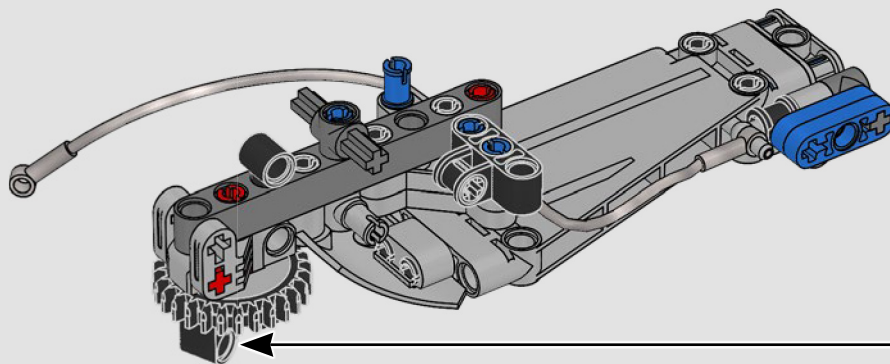

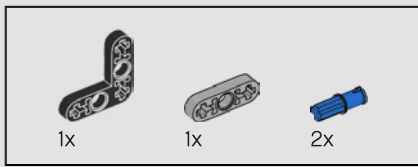

286

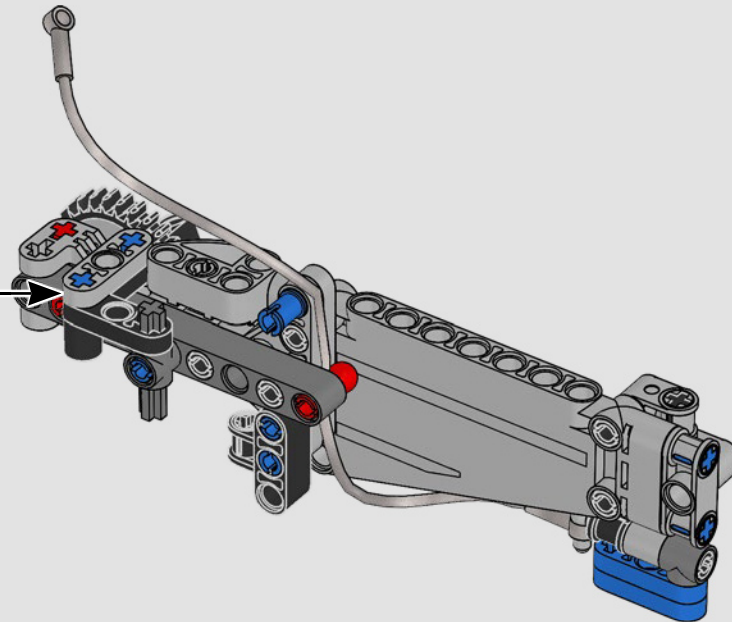
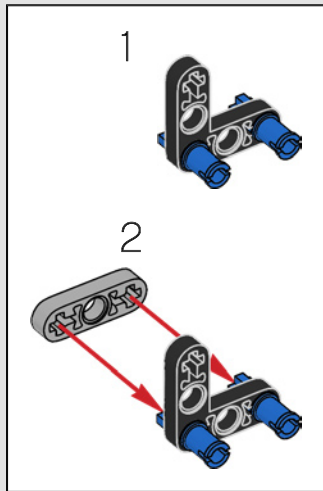

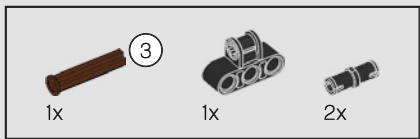

287

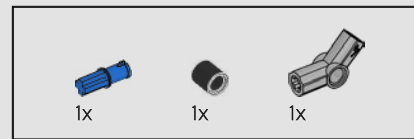
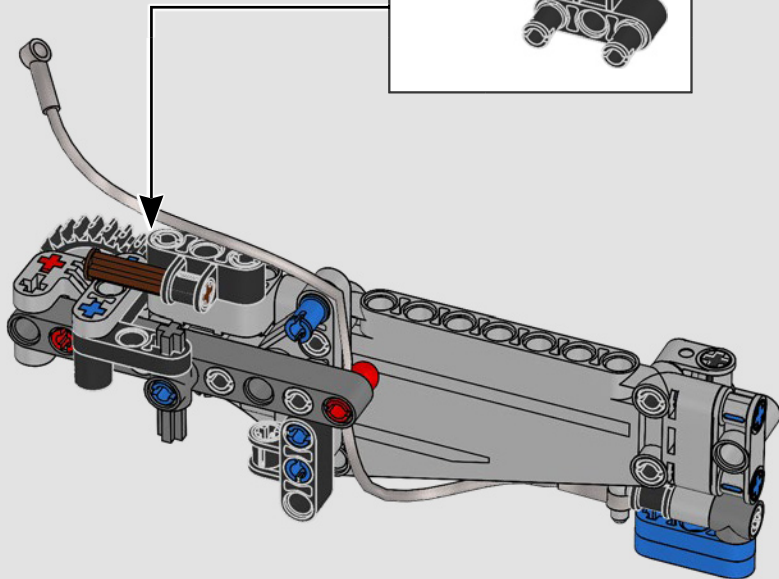
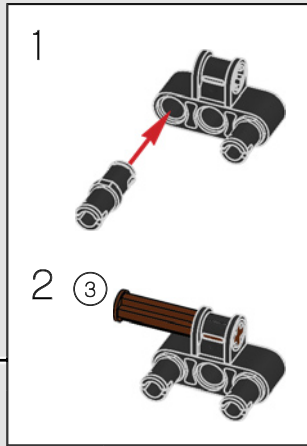

288

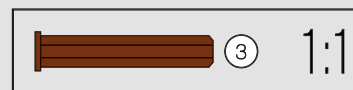
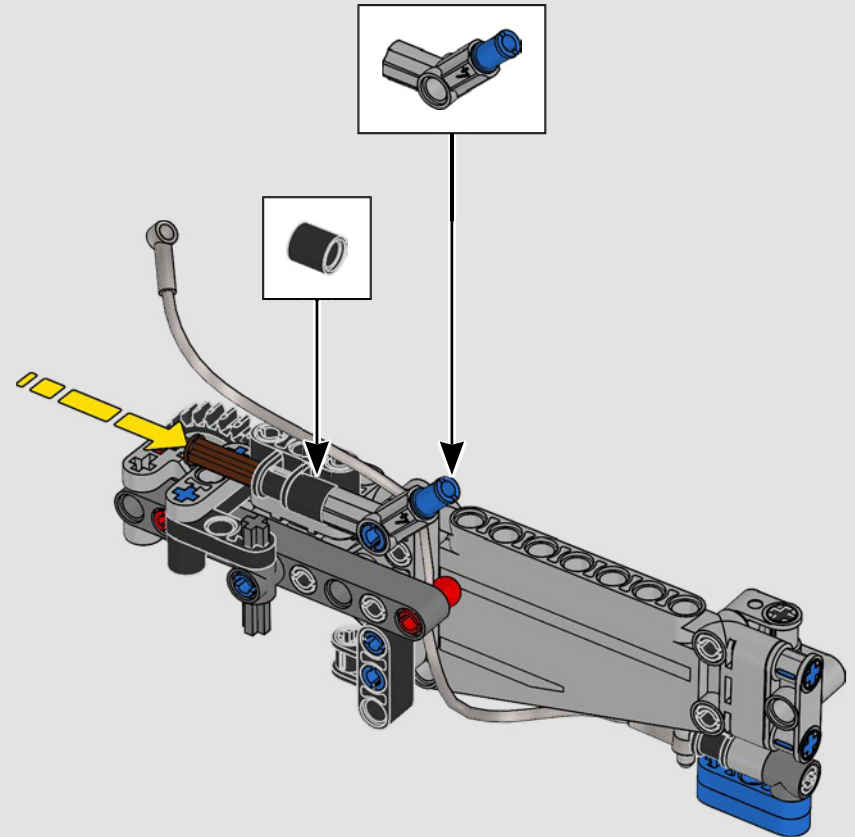

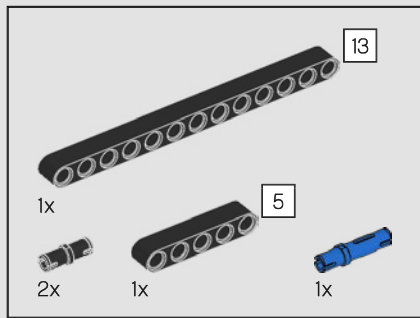

289

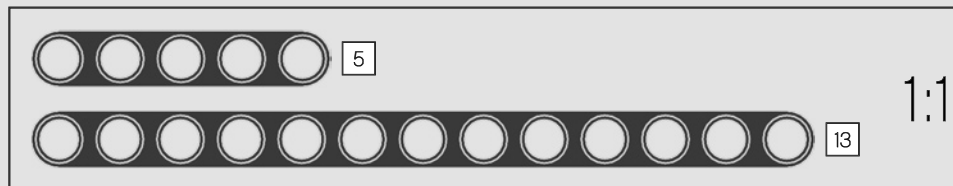
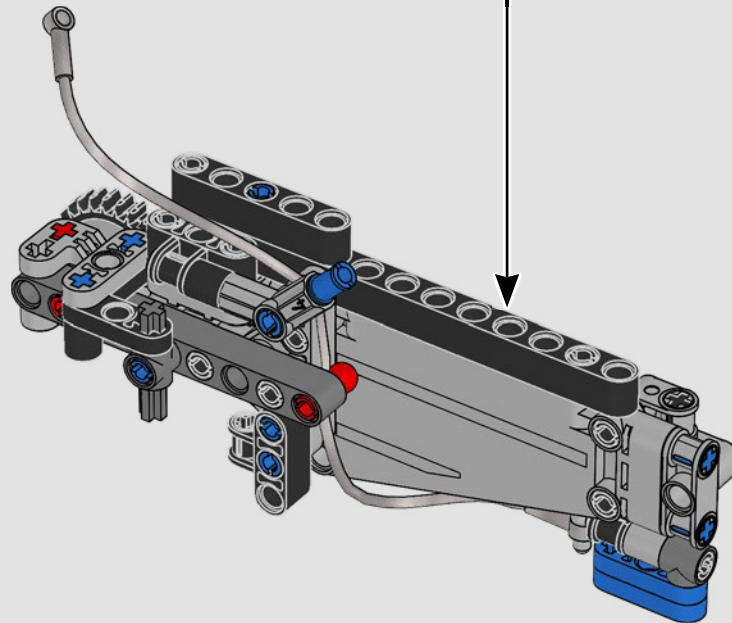
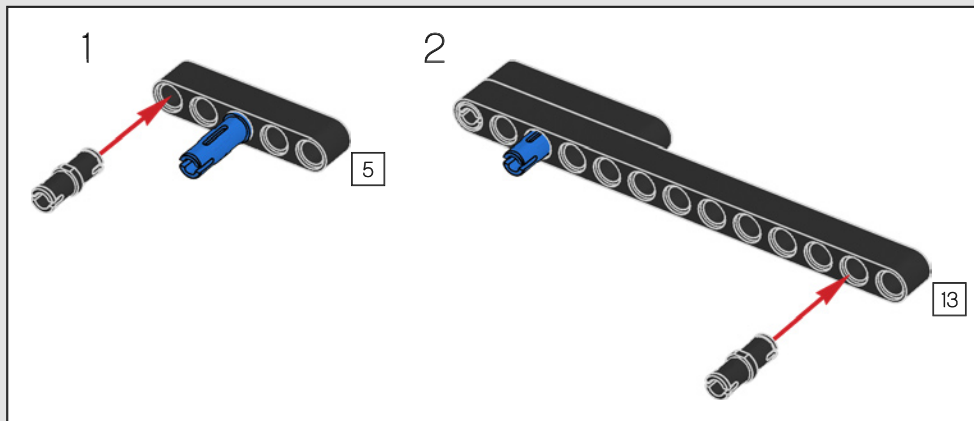

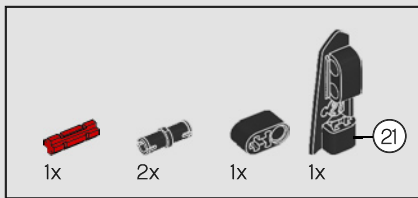

290

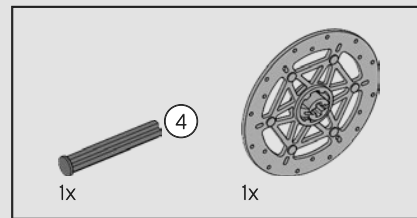
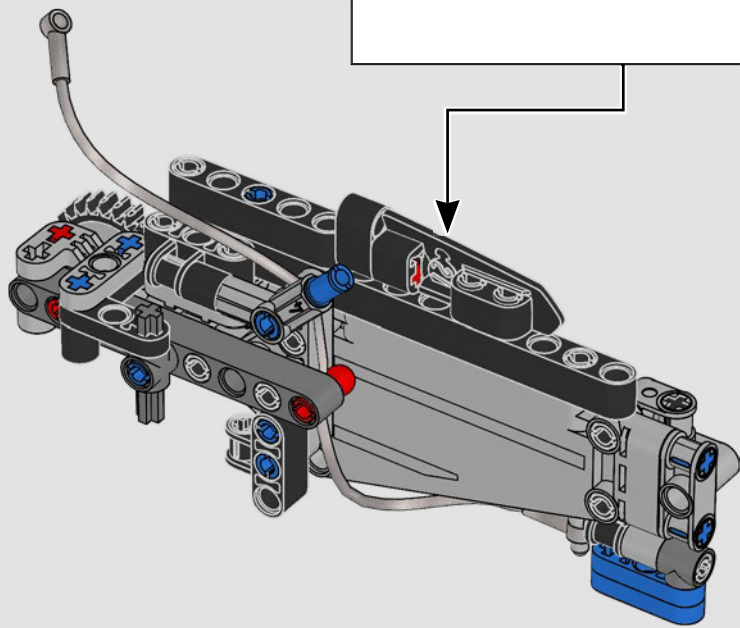
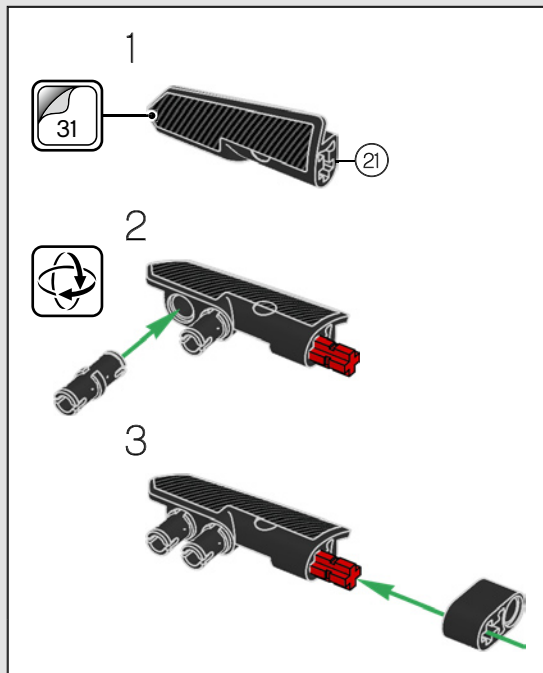

291

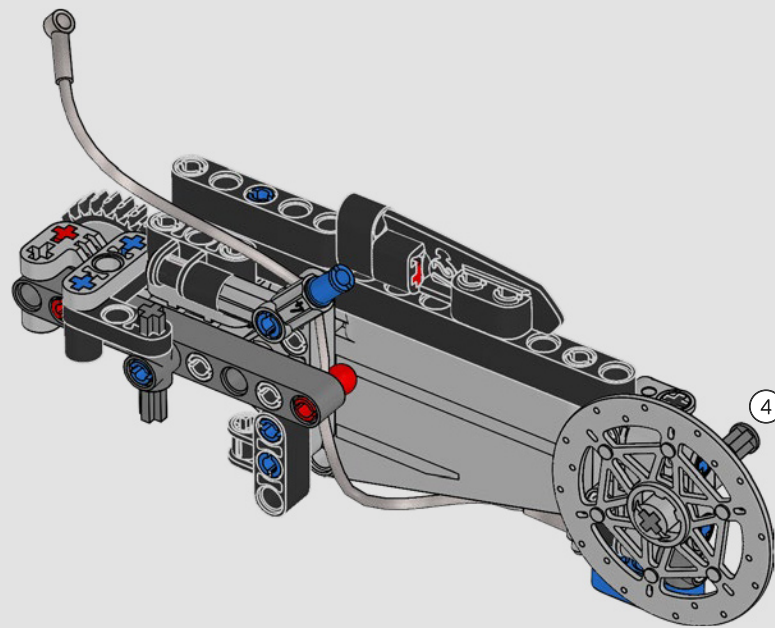
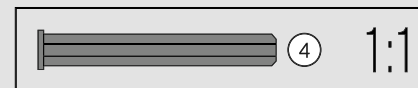

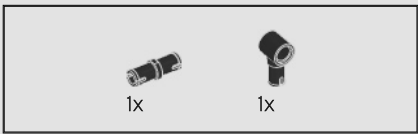

292

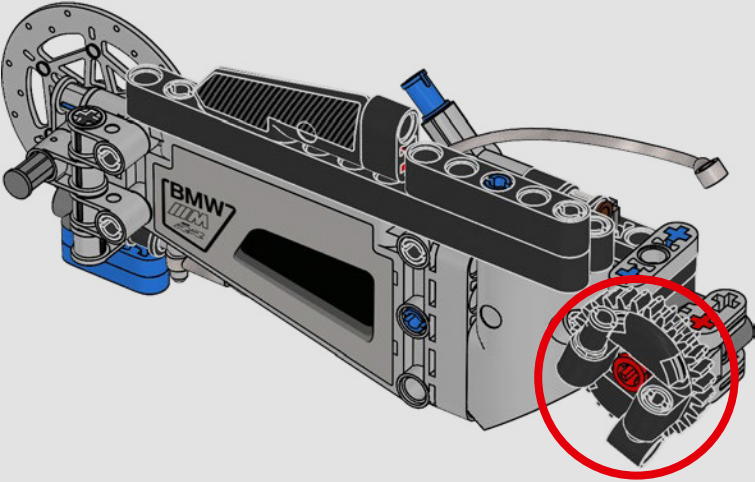

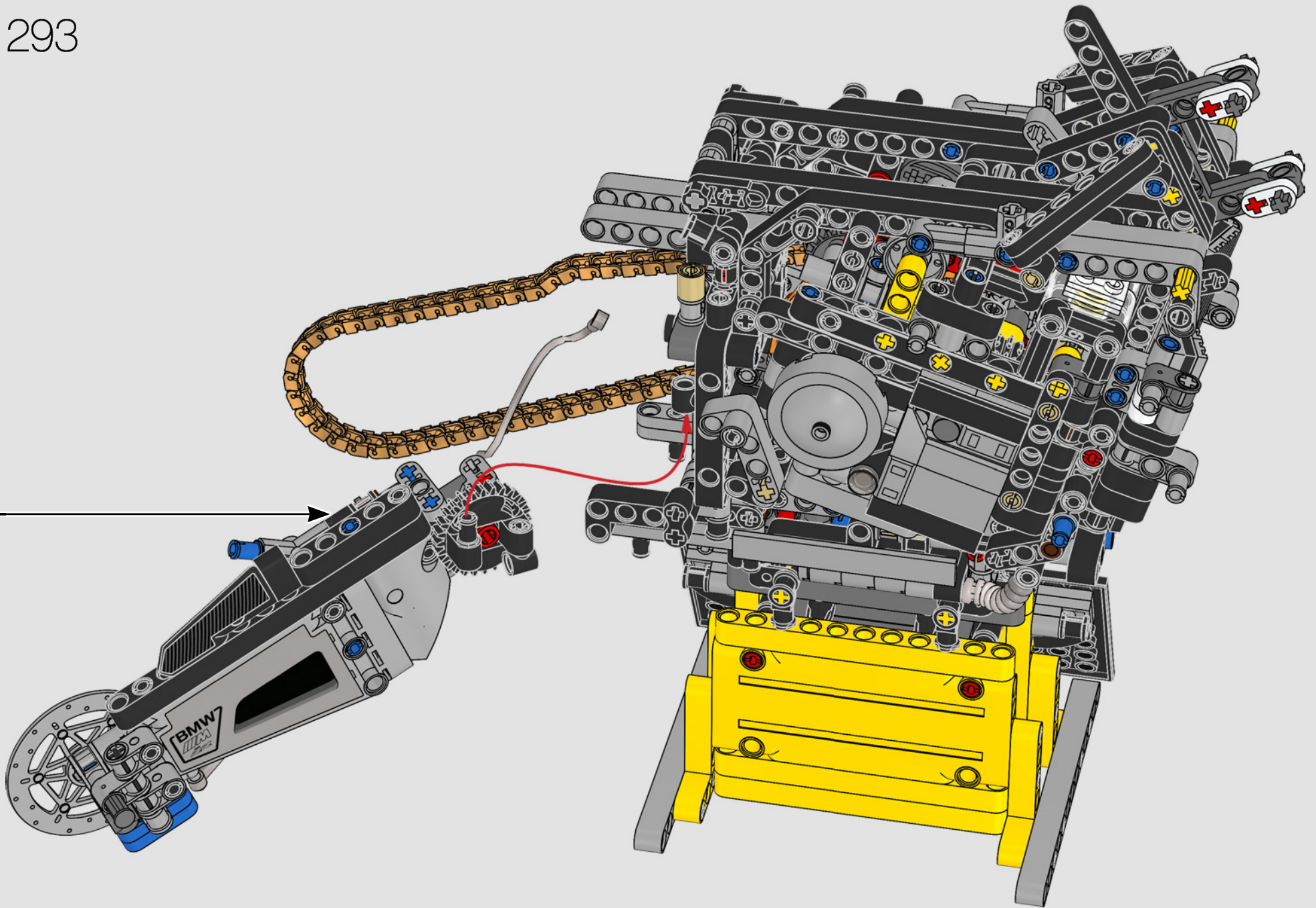

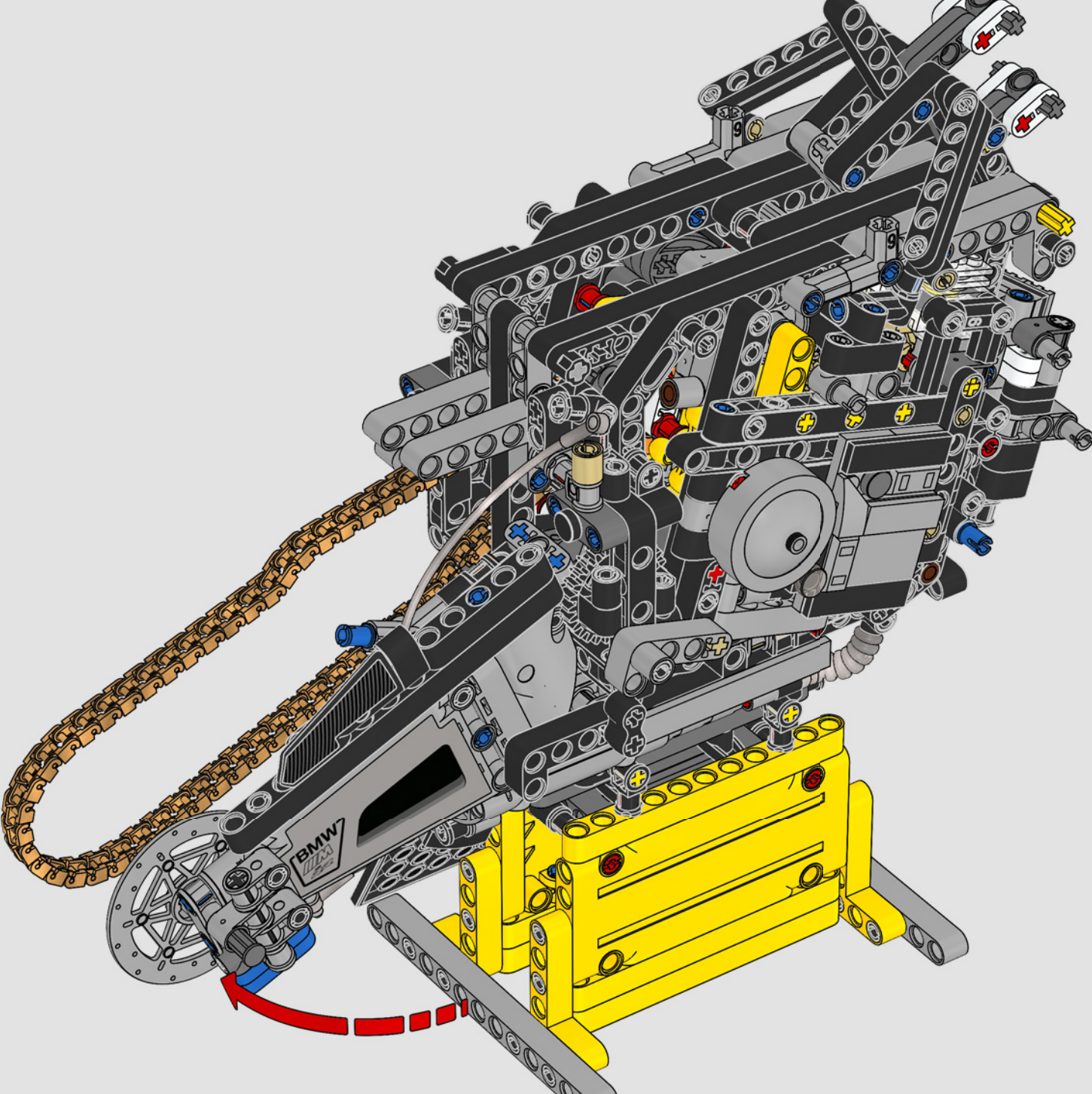

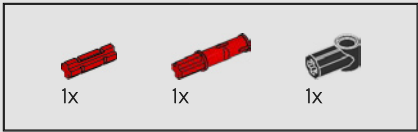

295

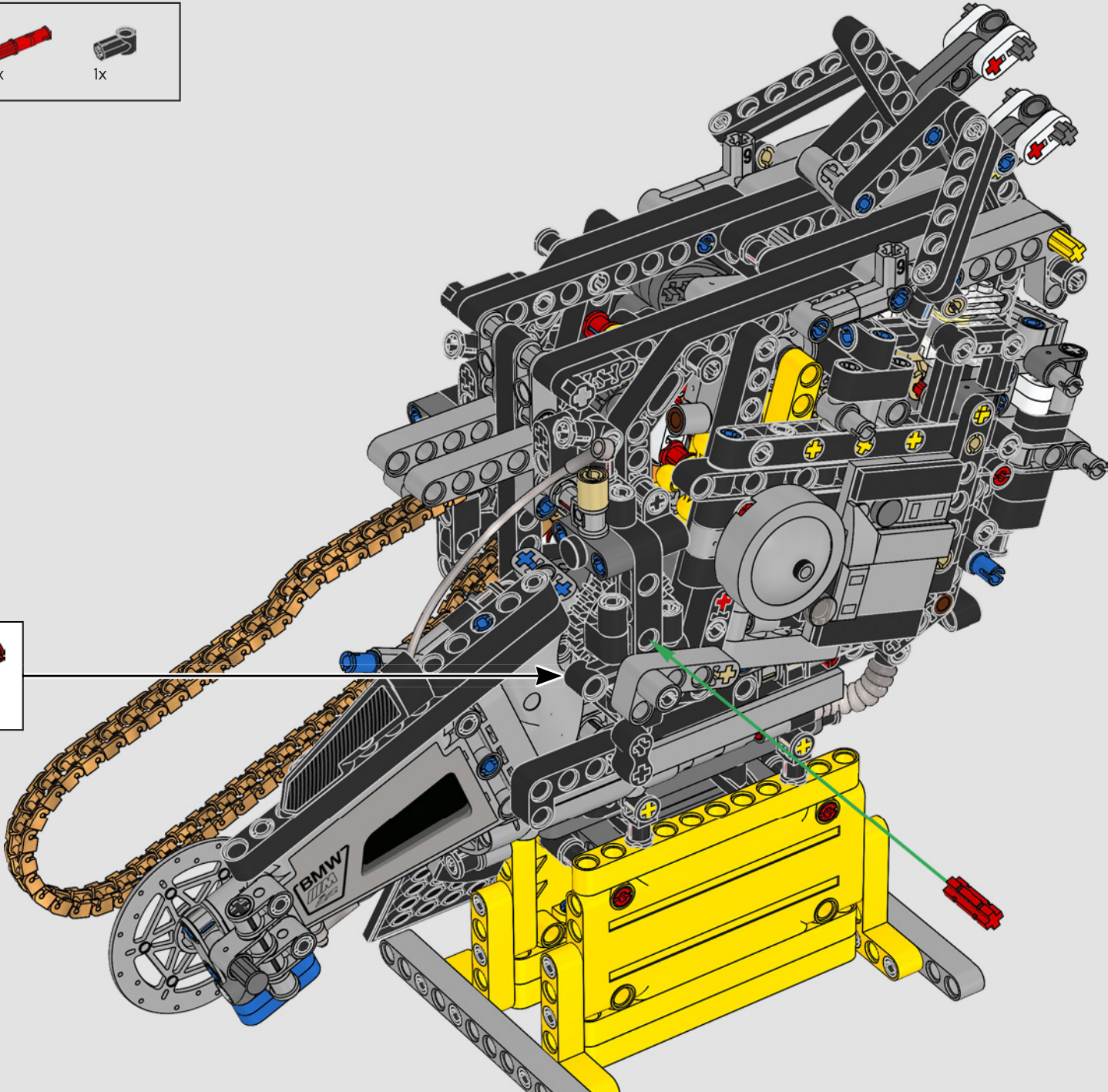
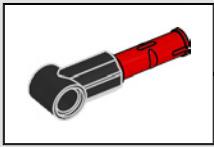

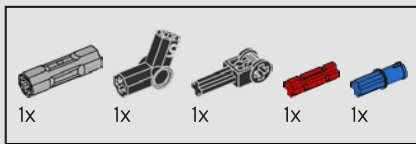

296

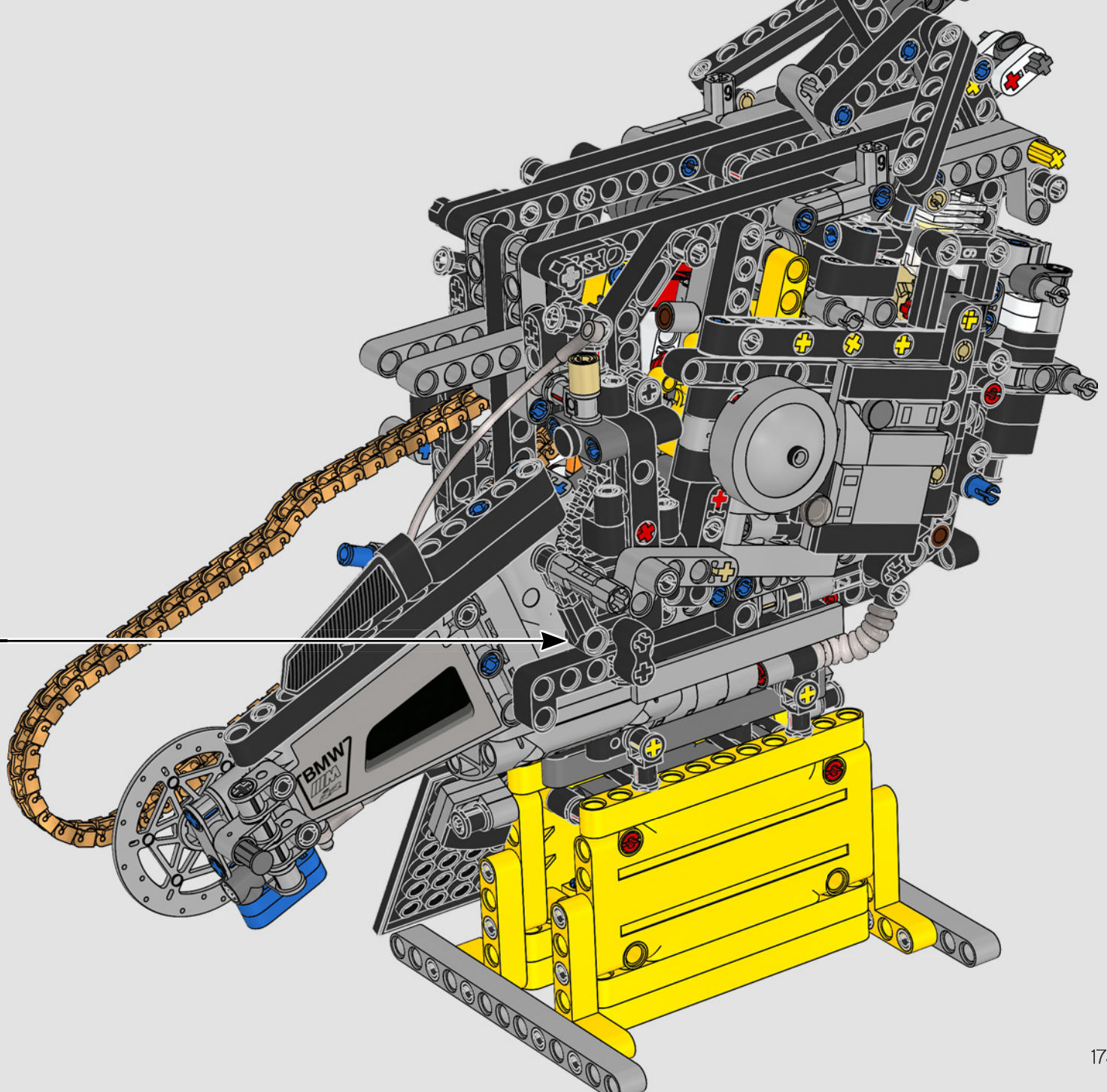
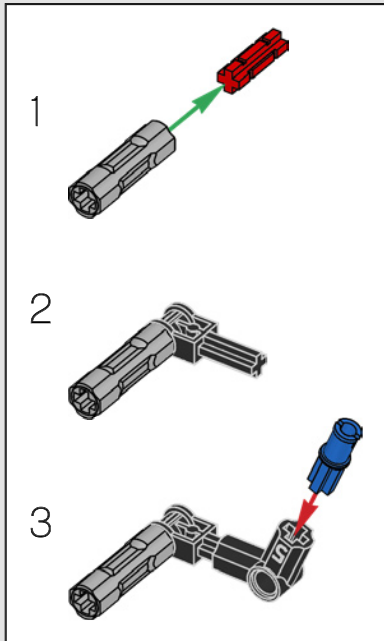

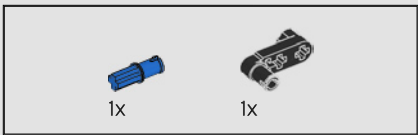

297

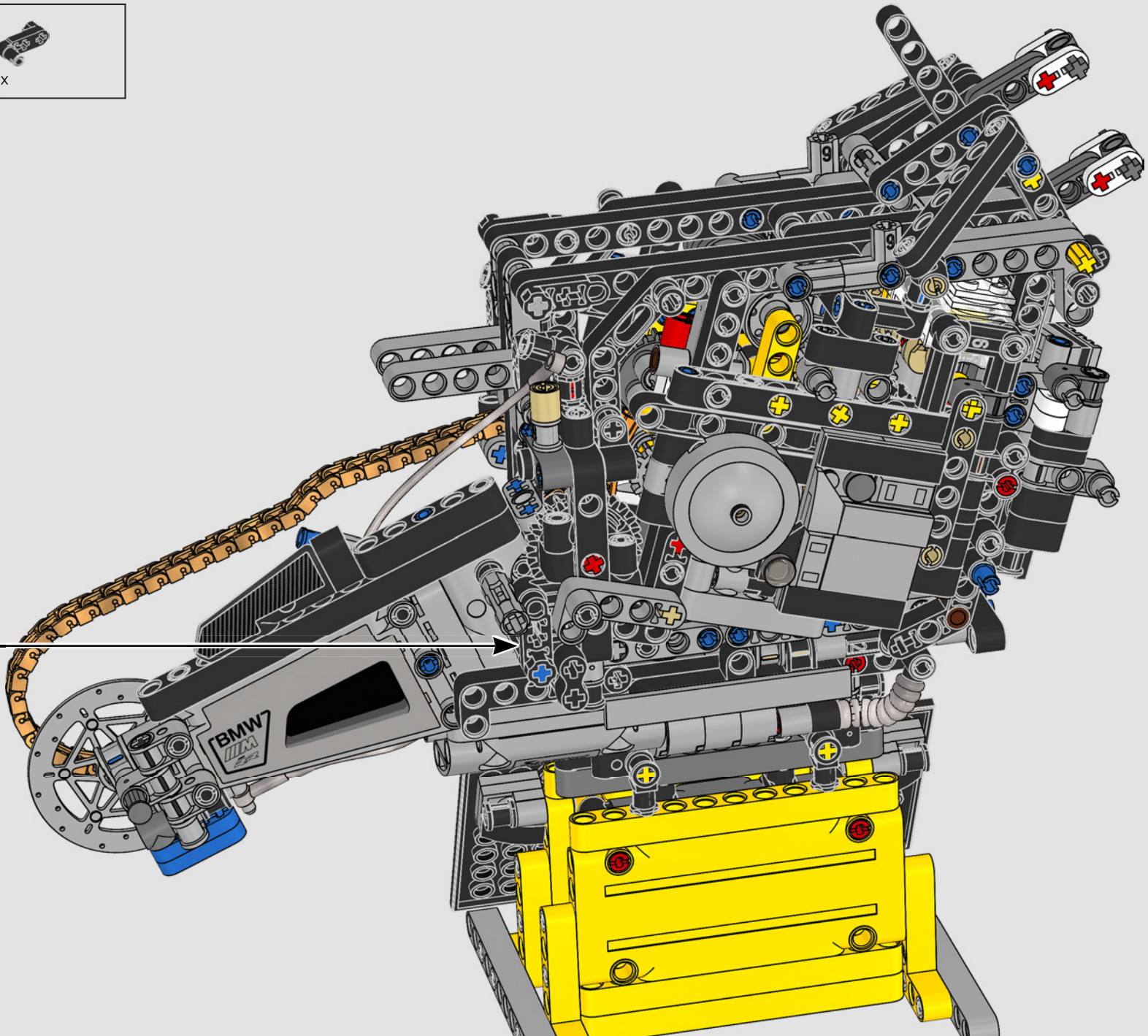
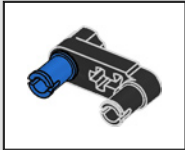

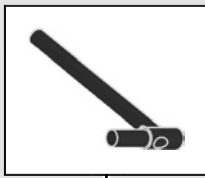
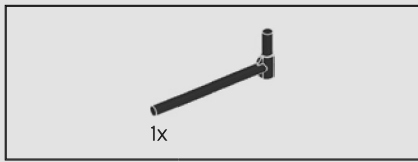

298

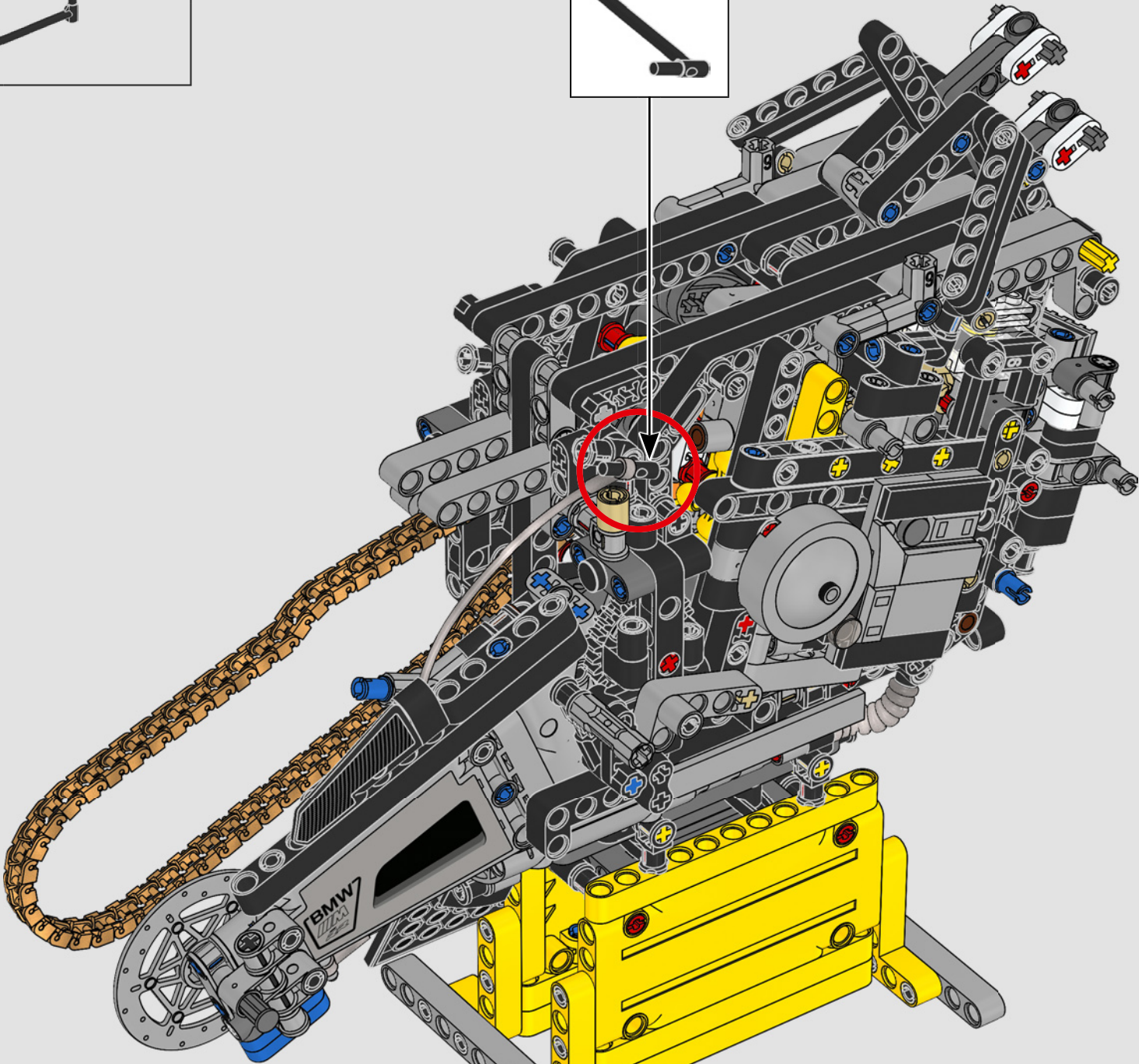

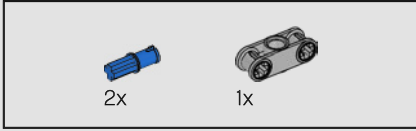
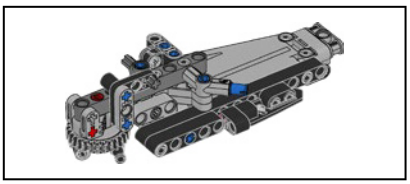

299

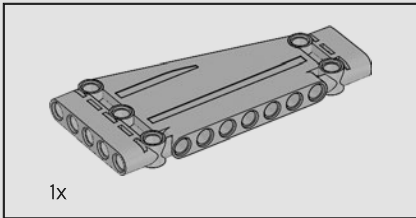
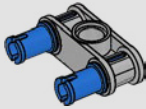

300

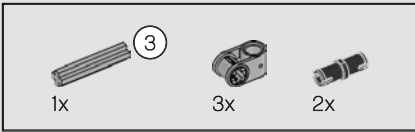
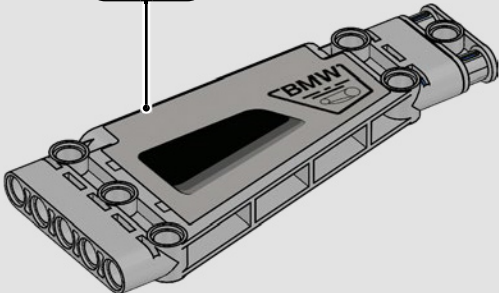

301

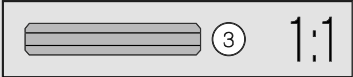
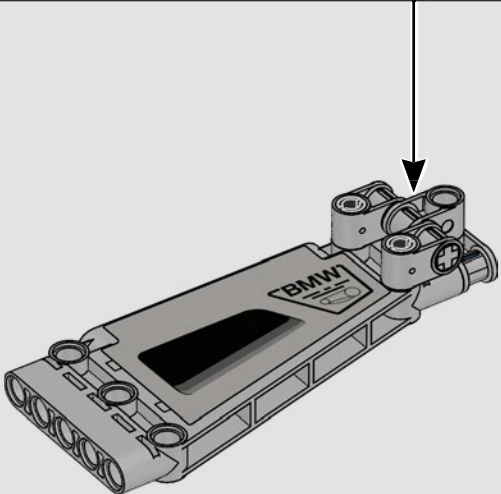
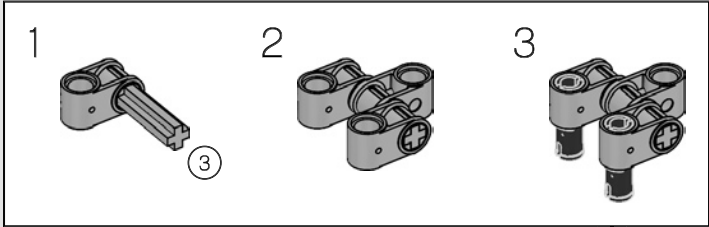

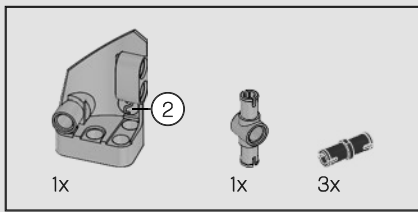

302

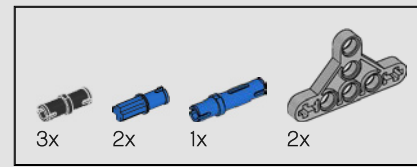
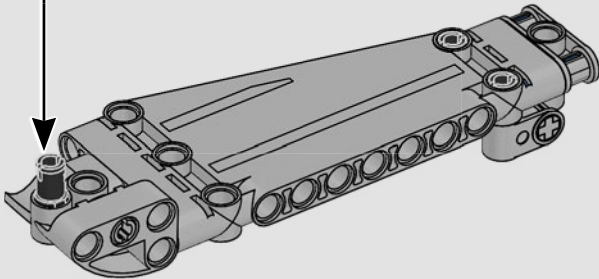
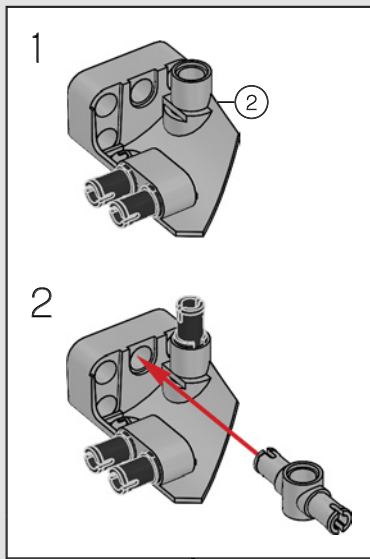

303

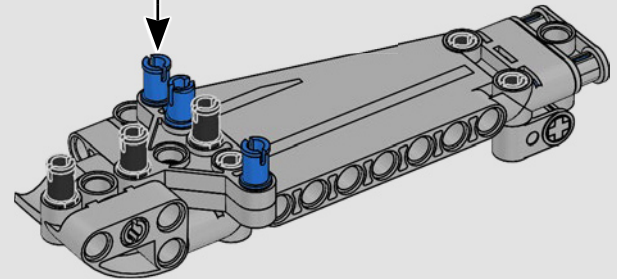
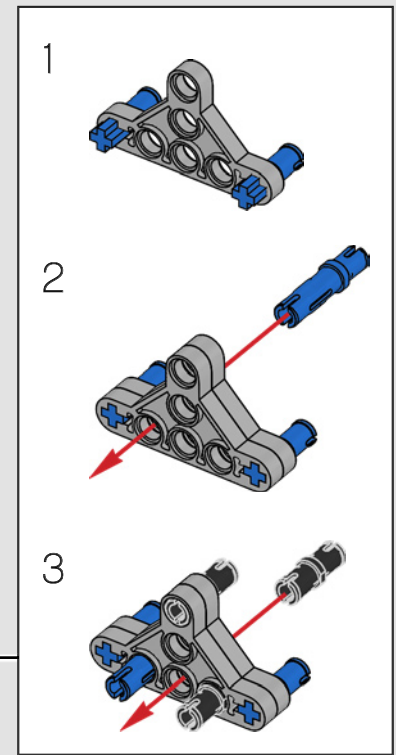

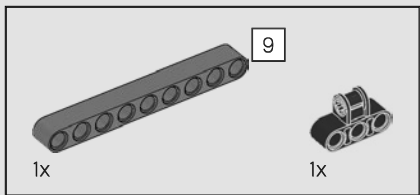

304

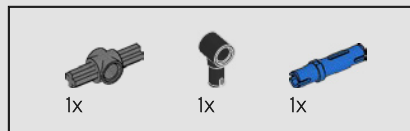
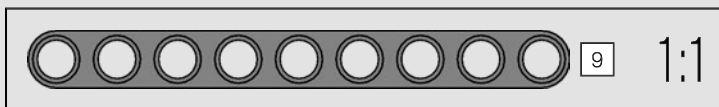
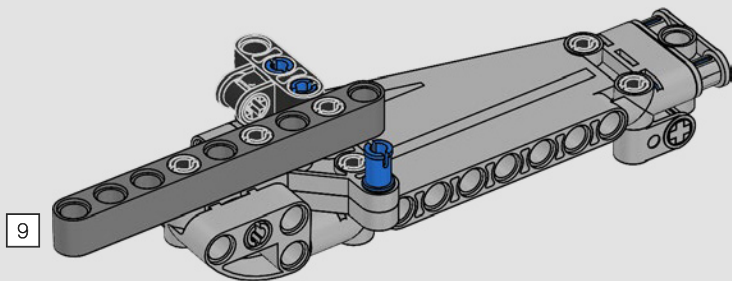

305

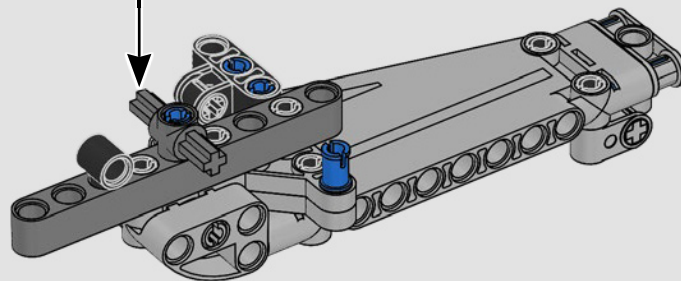
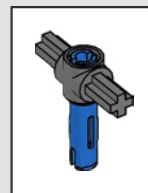

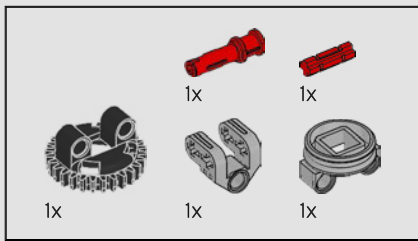

306

1

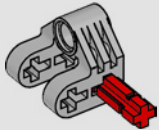

2

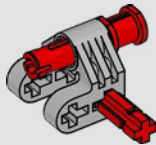

3

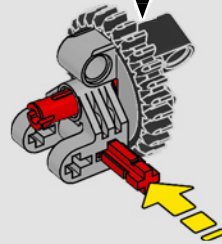

4

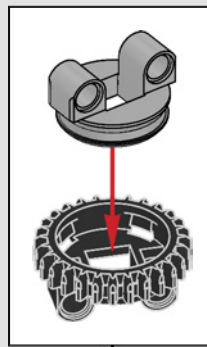
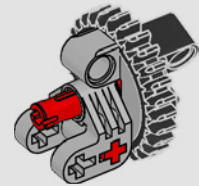

307

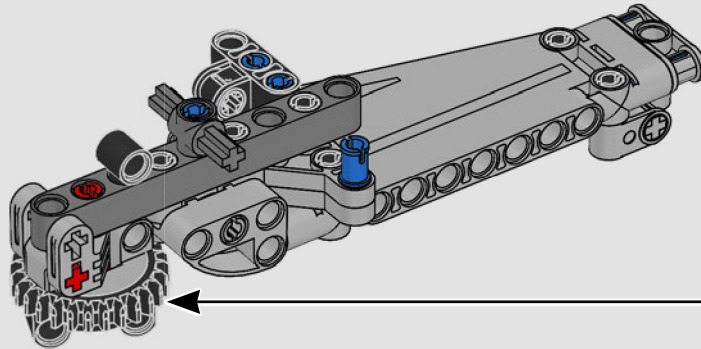

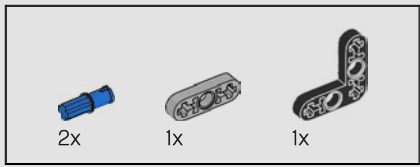

308

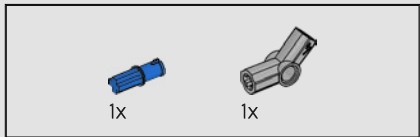
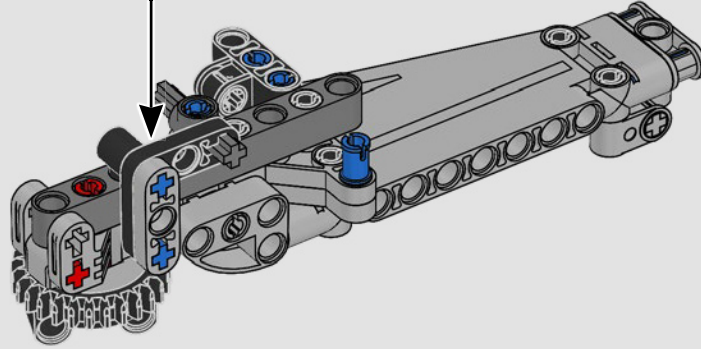
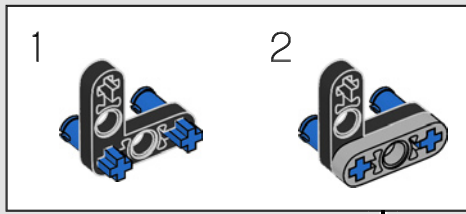

309

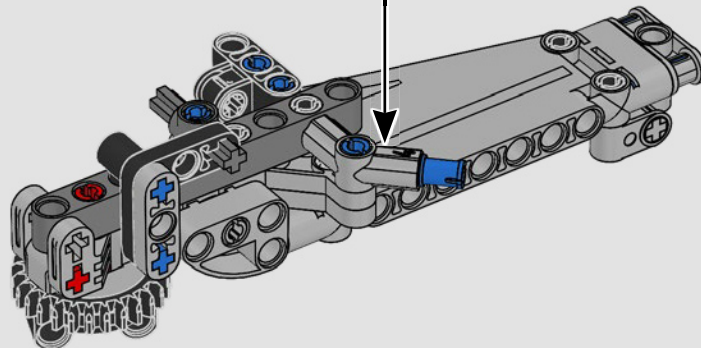
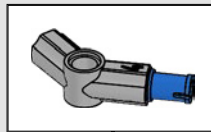

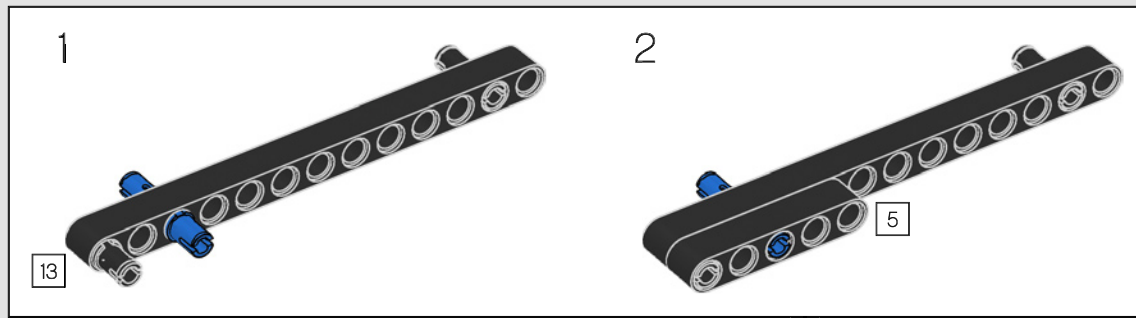
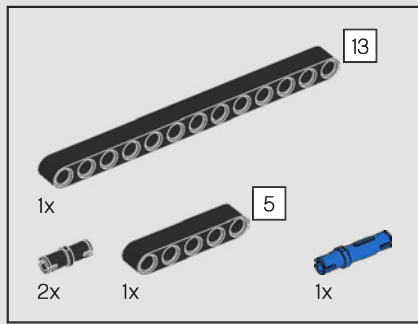

310

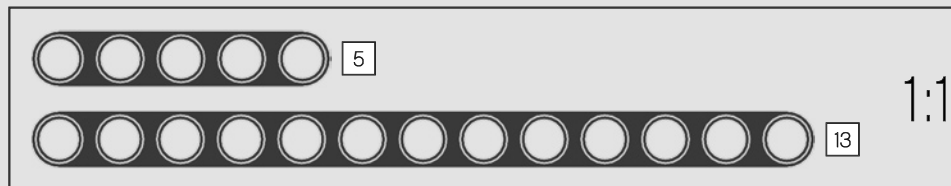
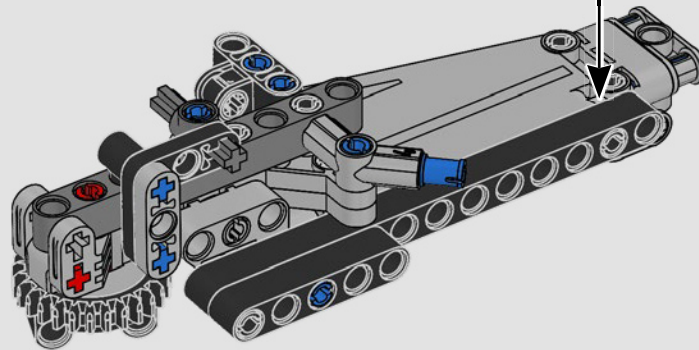

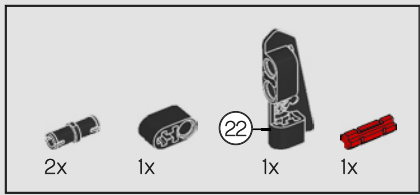

311

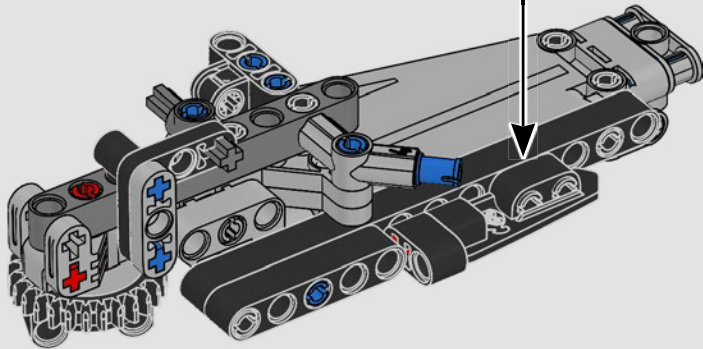
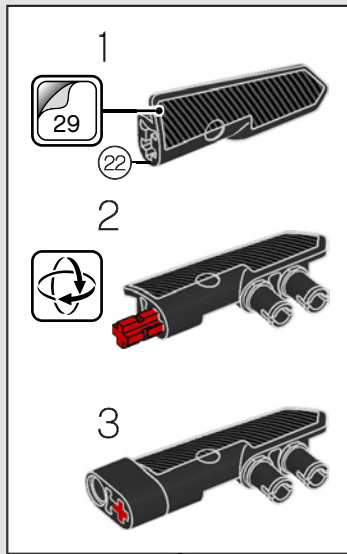

312

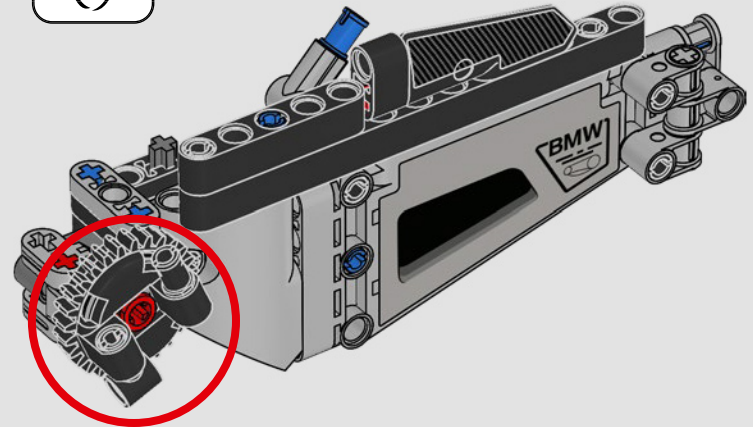
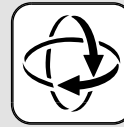

313

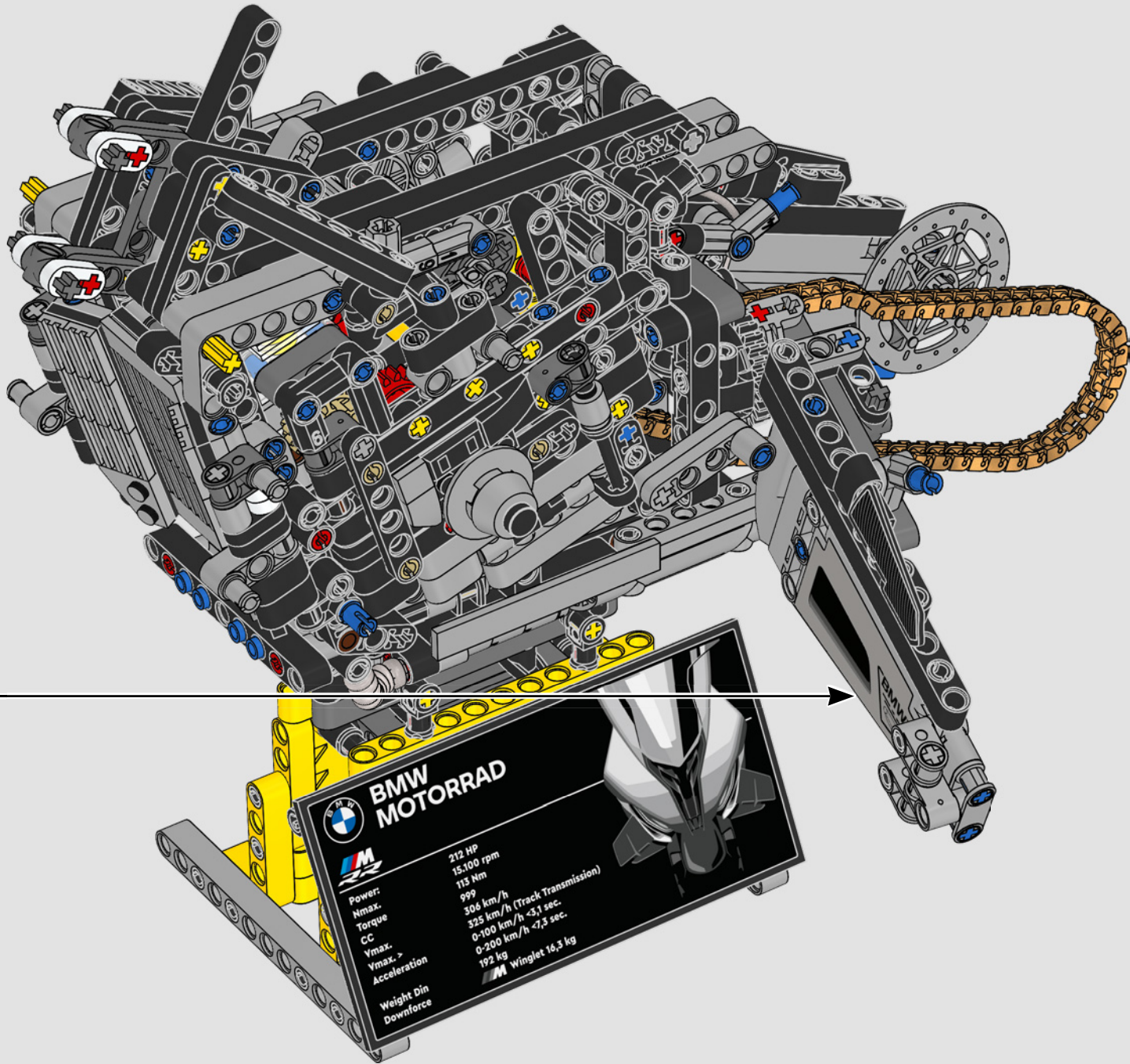

BMW MOTORRAD

Power:	212 HP
Nmax.	15,100 rpm
Torque	113 Nm
CC	999
Vmax.	306 km/h (Track Transmission)
Acceleration	0-100 km/h <3,1 sec.
Weight Din	0-200 km/h <7,3 sec.
Downforce	192 kg
	Winglet 16,3 kg

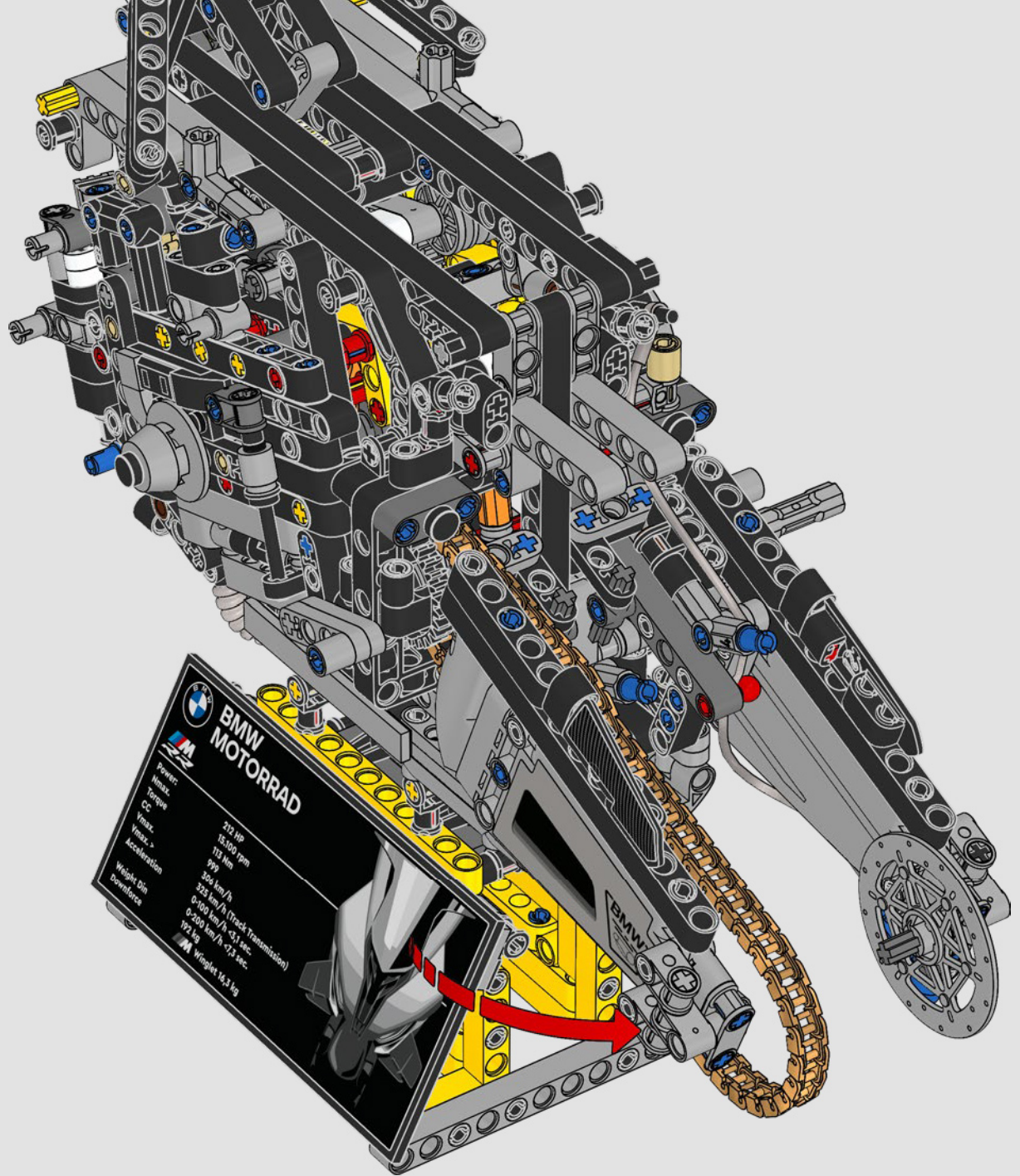
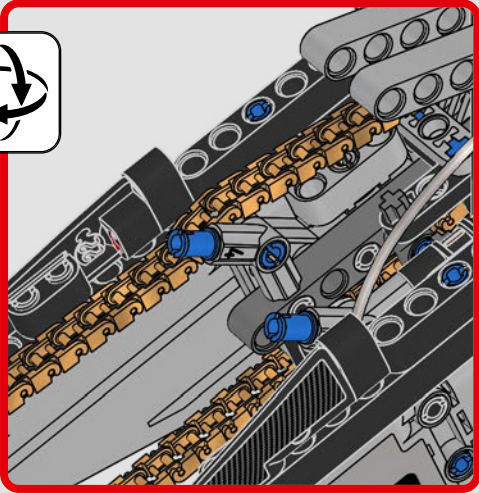

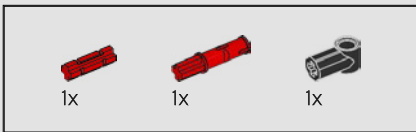

315

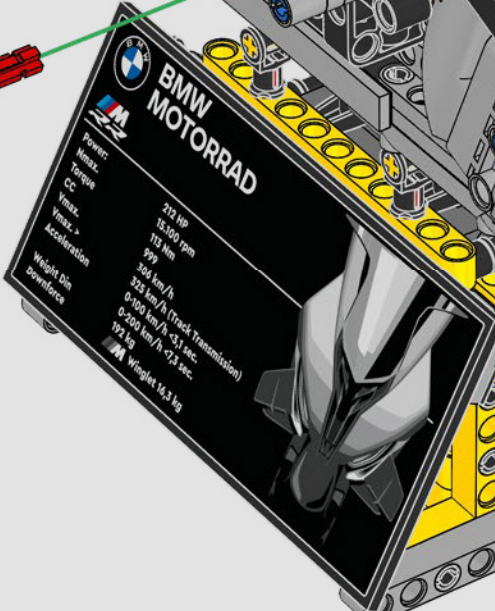
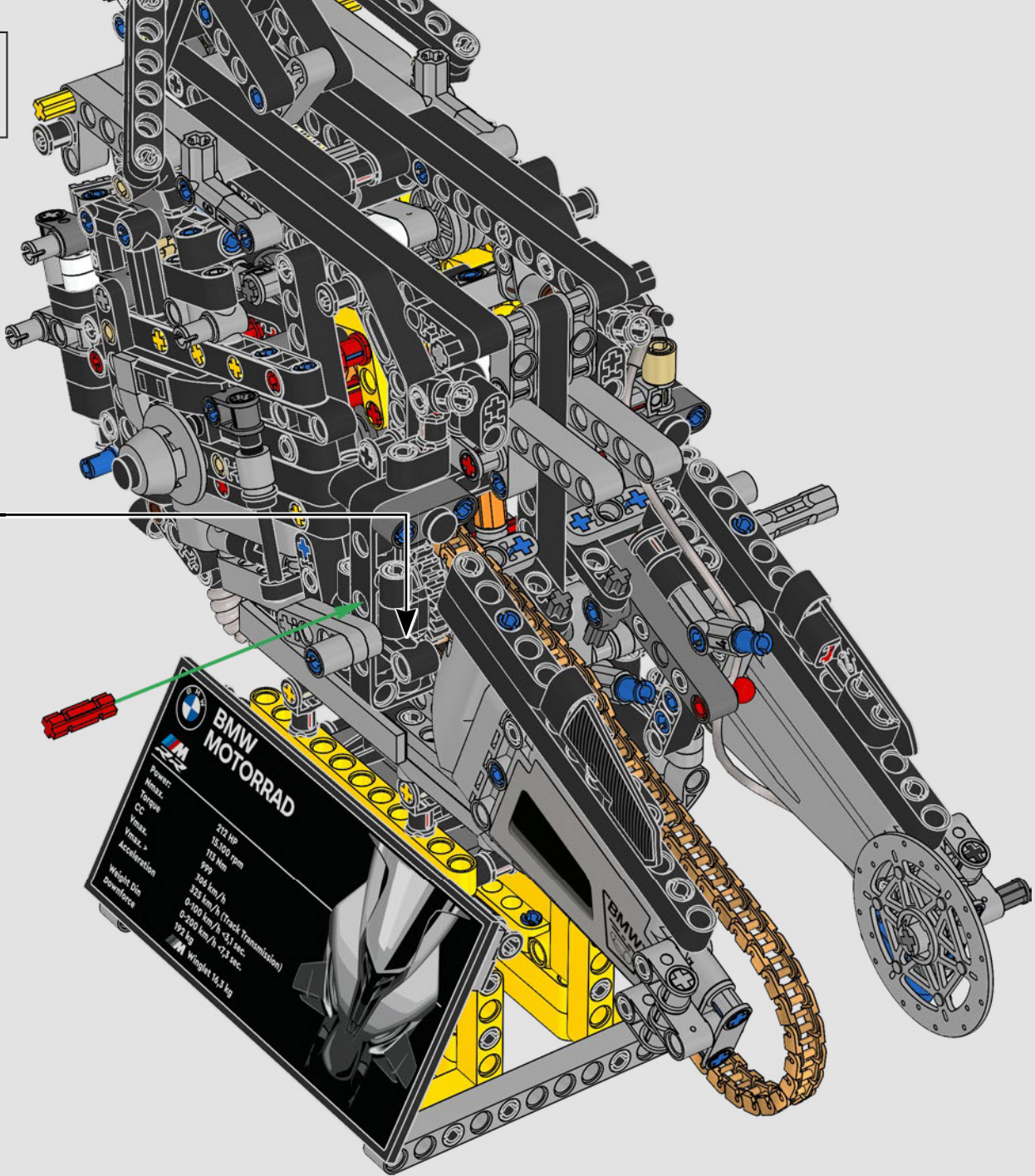
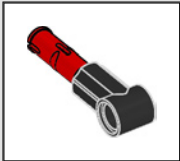

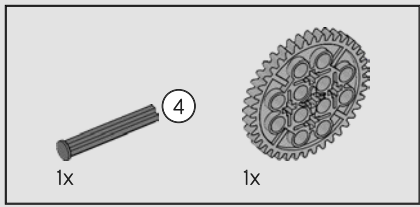

316

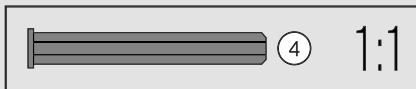
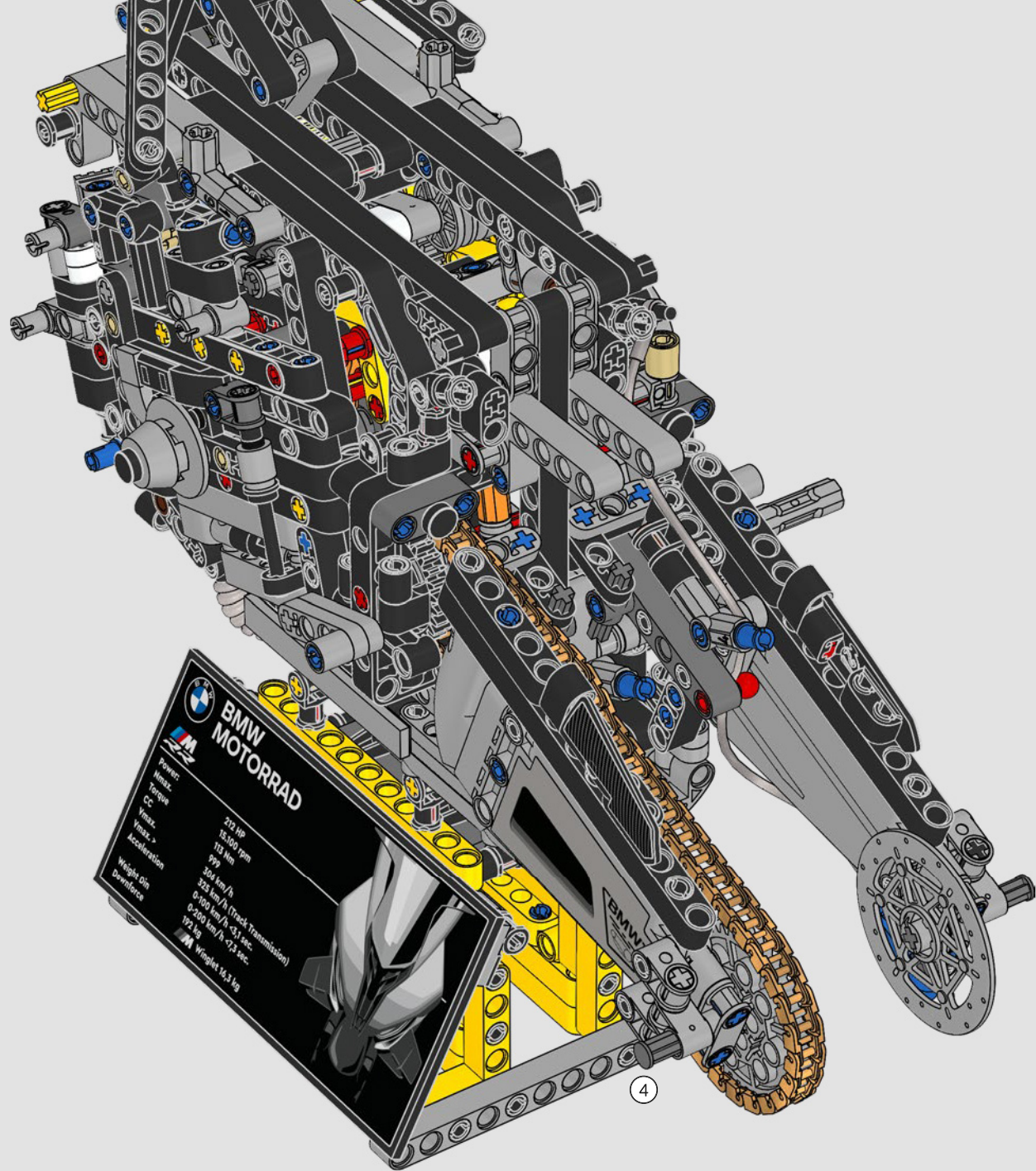

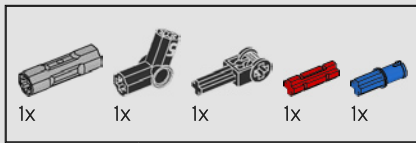

317

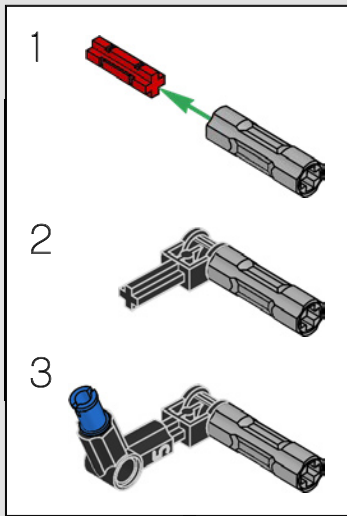
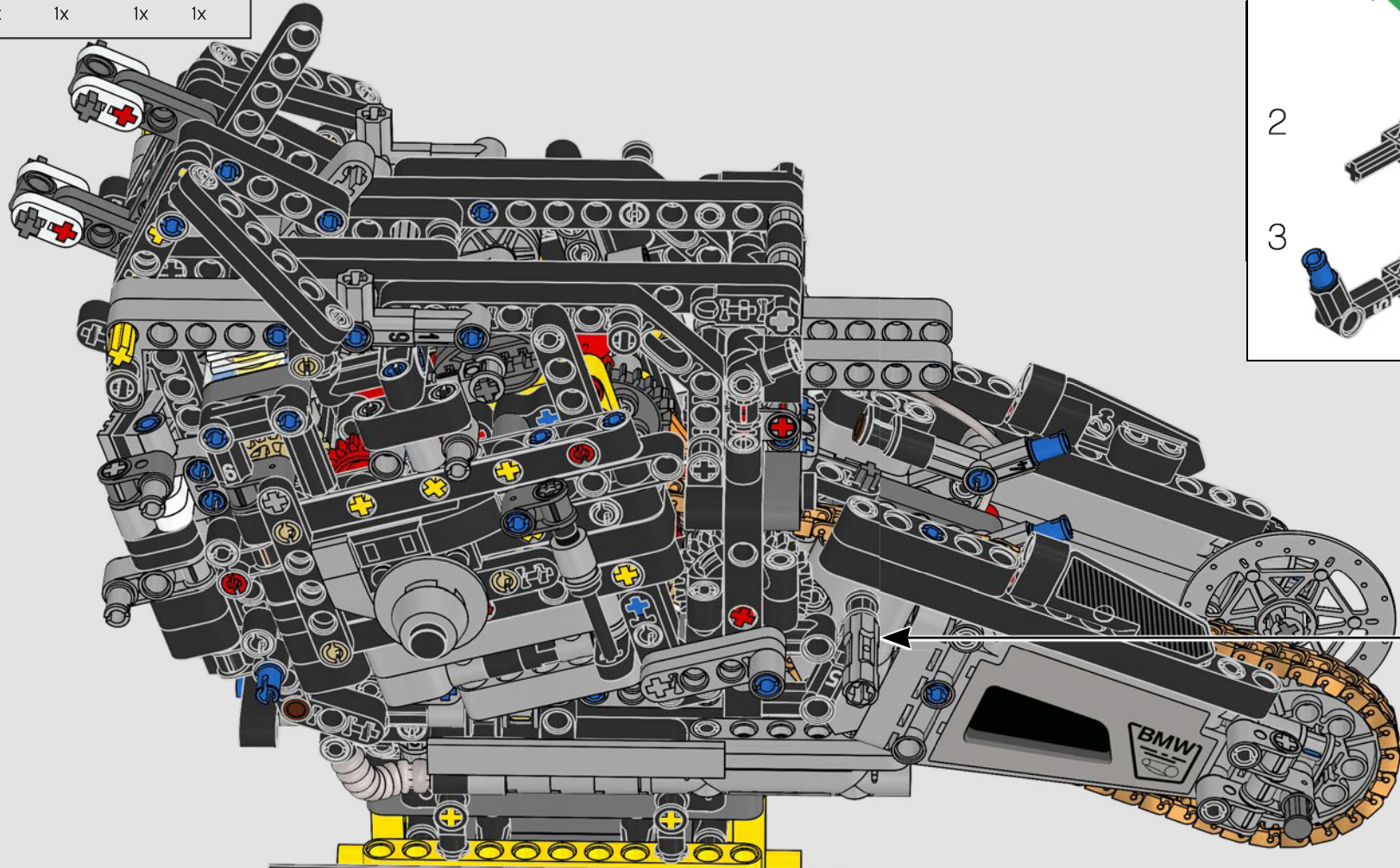

BMW MOTORRAD

Power:	212 HP
Nmax:	15.100 rpm
Torque	113 Nm
CC	999
Vmax:	306 km/h
Vmax. >	325 km/h (Track Transmission)
Acceleration	0-100 km/h <3,1 sec.
	0-200 km/h <7,3 sec.
Weight Din	192 kg
Downforce	Winglet 16,3 kg

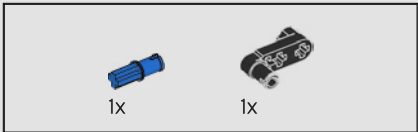

318

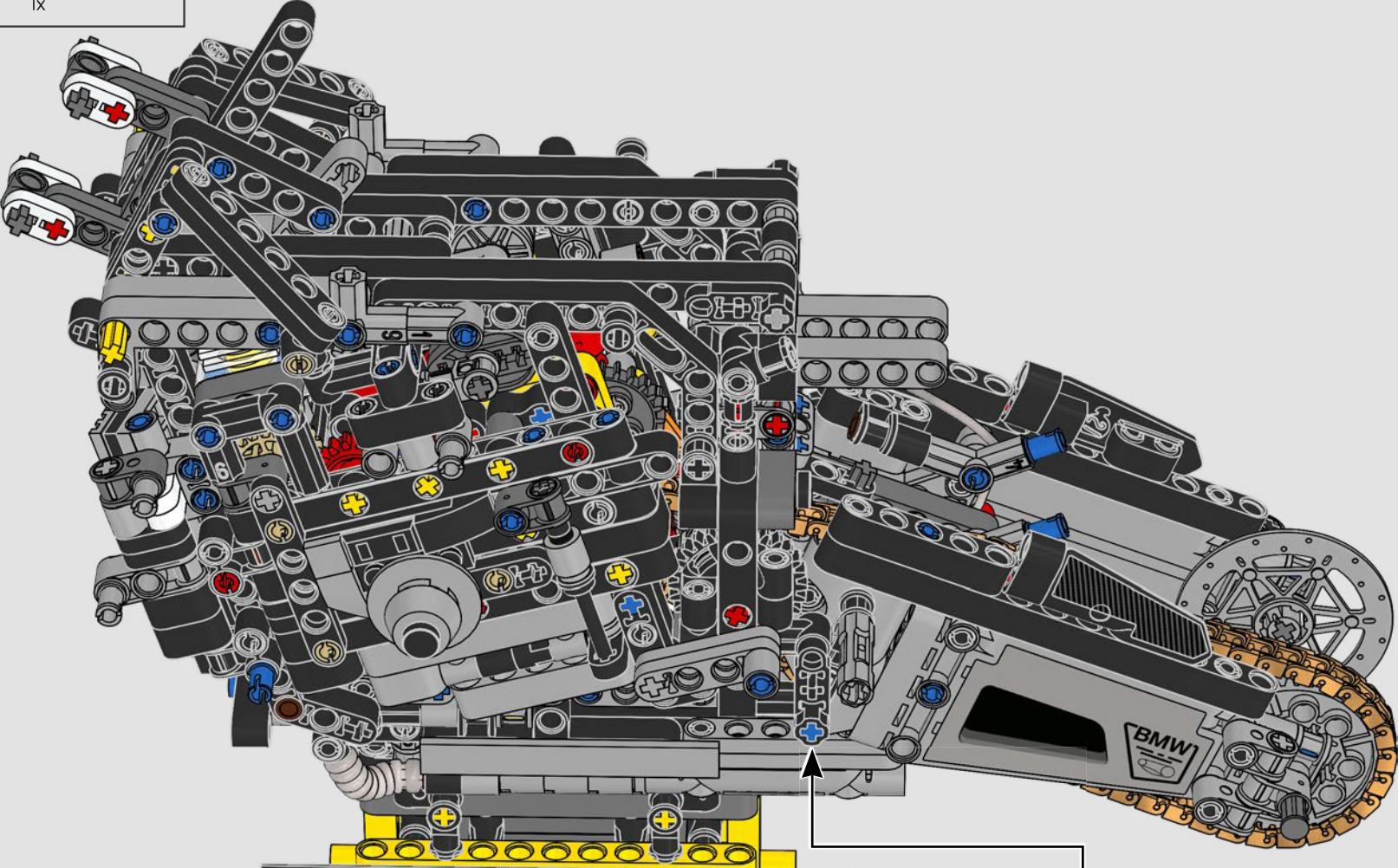

BMW

MOTORRAD

Power: 212 HP

Nmax: 15.100 rpm

Torque 113 Nm

CC 999

Vmax. 306 km/h

Vmax. > 325 km/h (Track Transmission)

Acceleration 0-100 km/h <3,1 sec.

0-200 km/h <7,3 sec.

Weight Din 192 kg

Downforce Winglet 16,3 kg

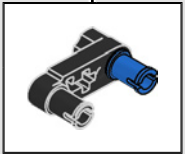

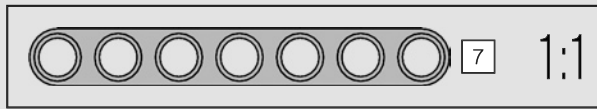
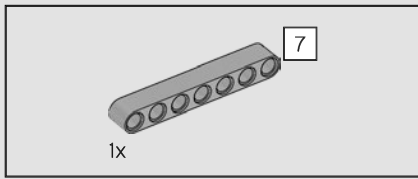

319

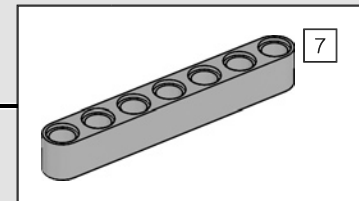
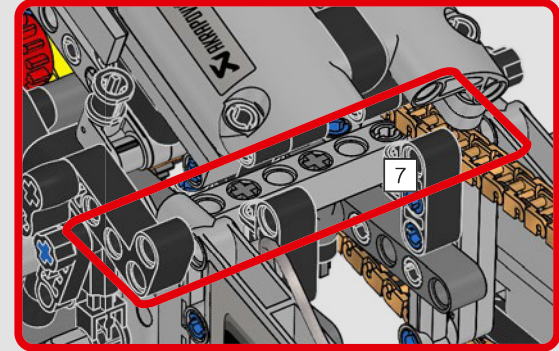
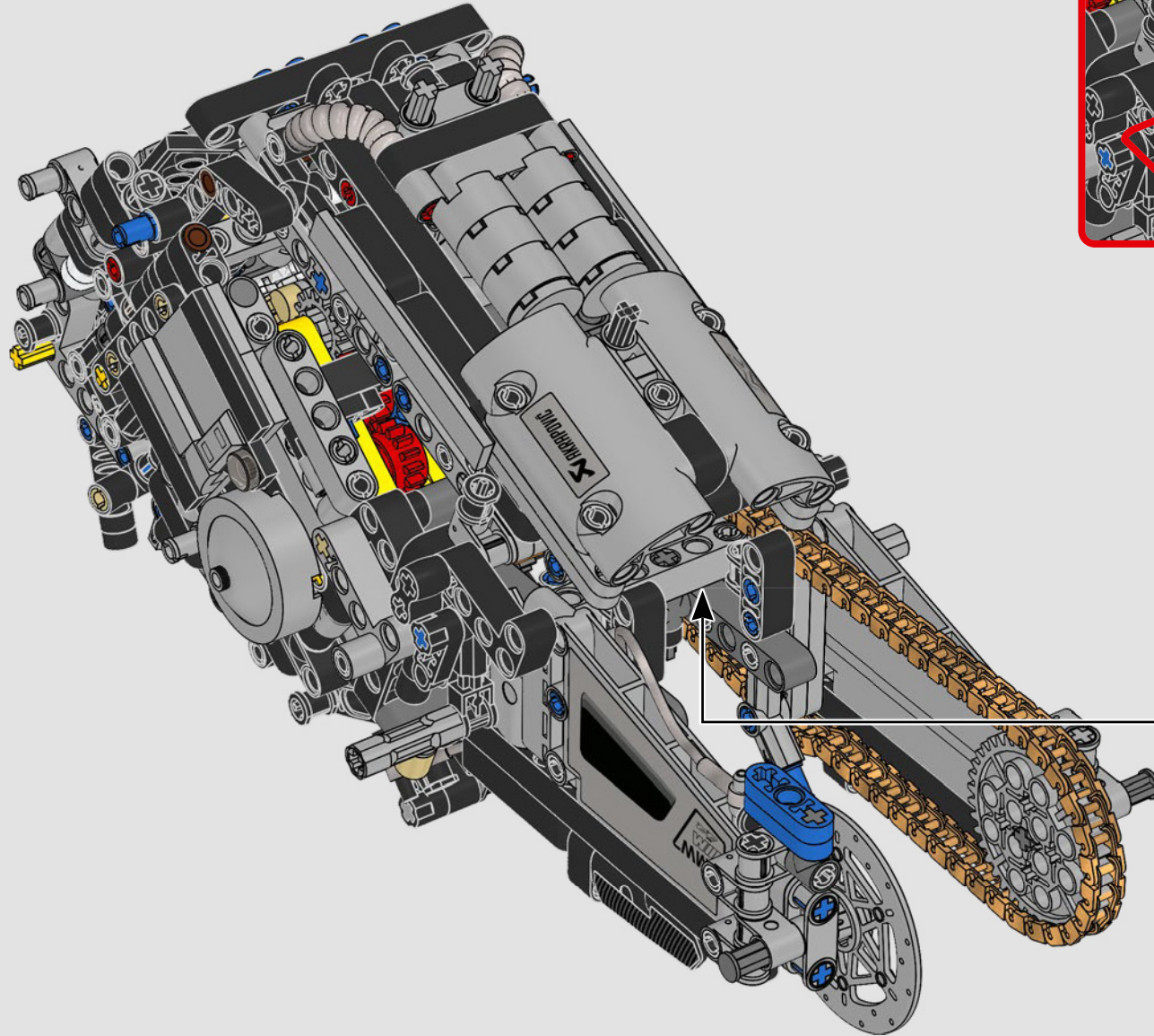

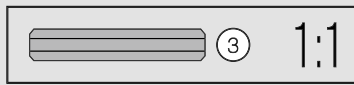
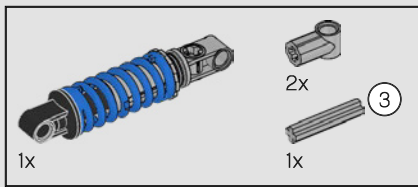

320

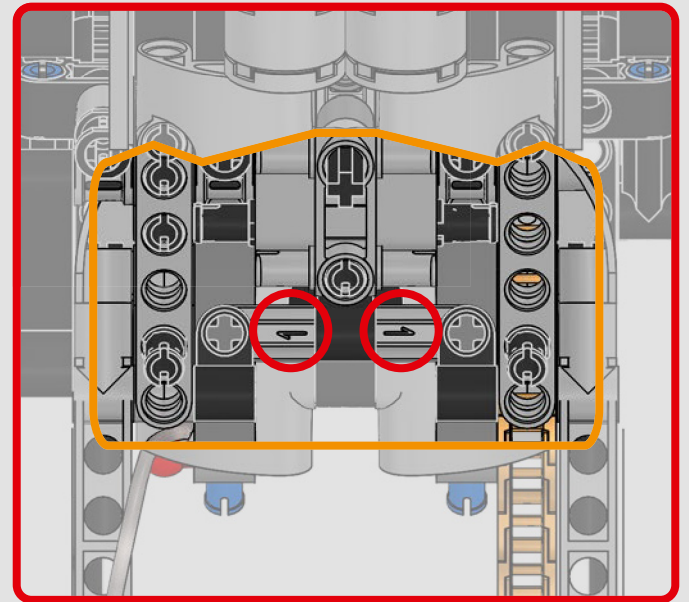
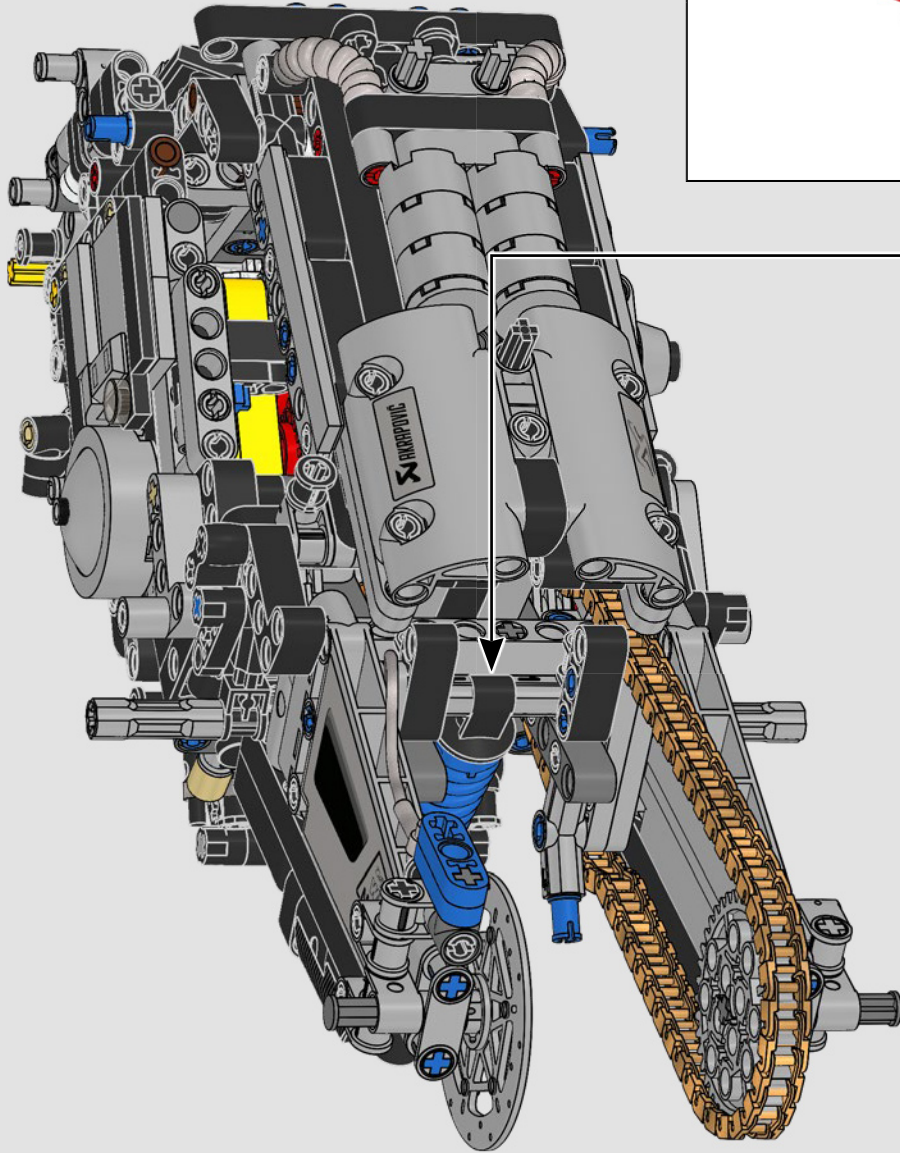
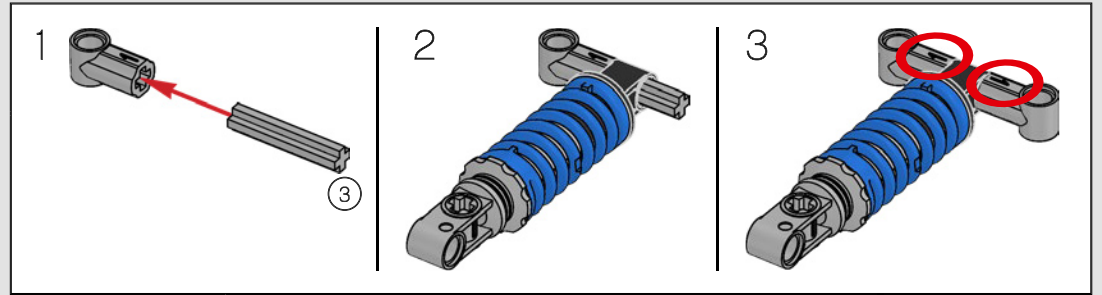

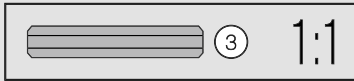
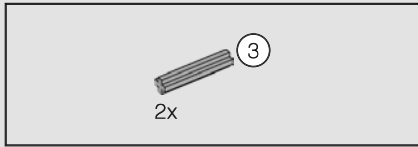

321

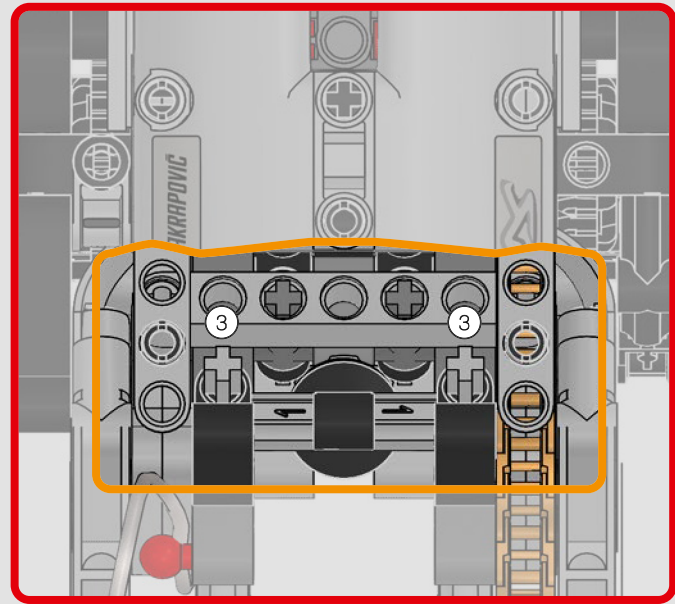
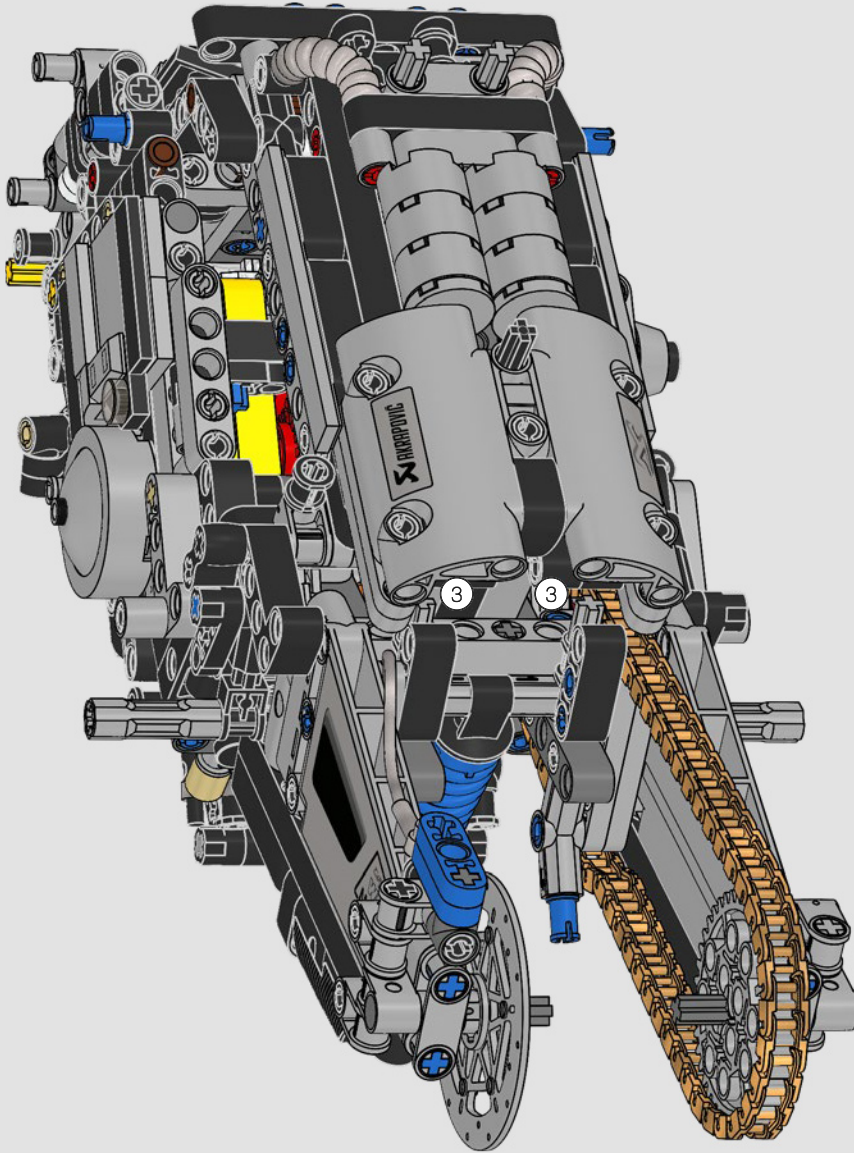

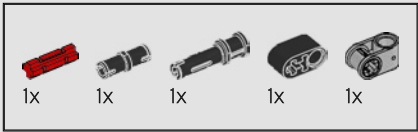

322

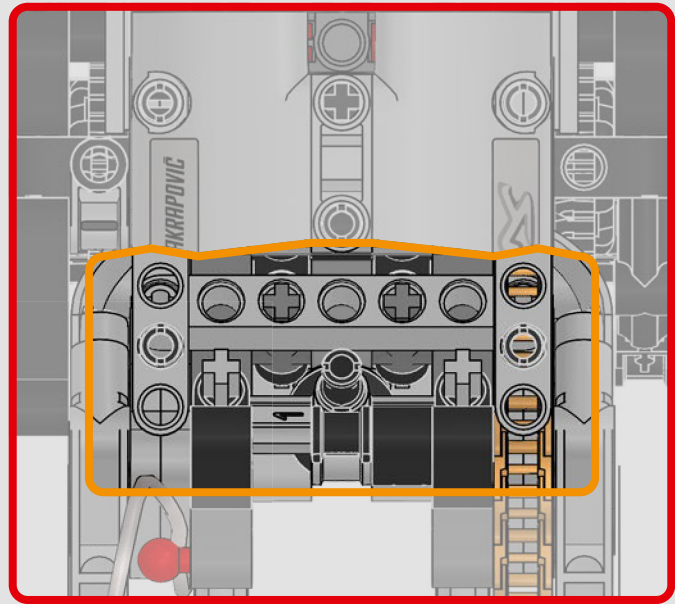
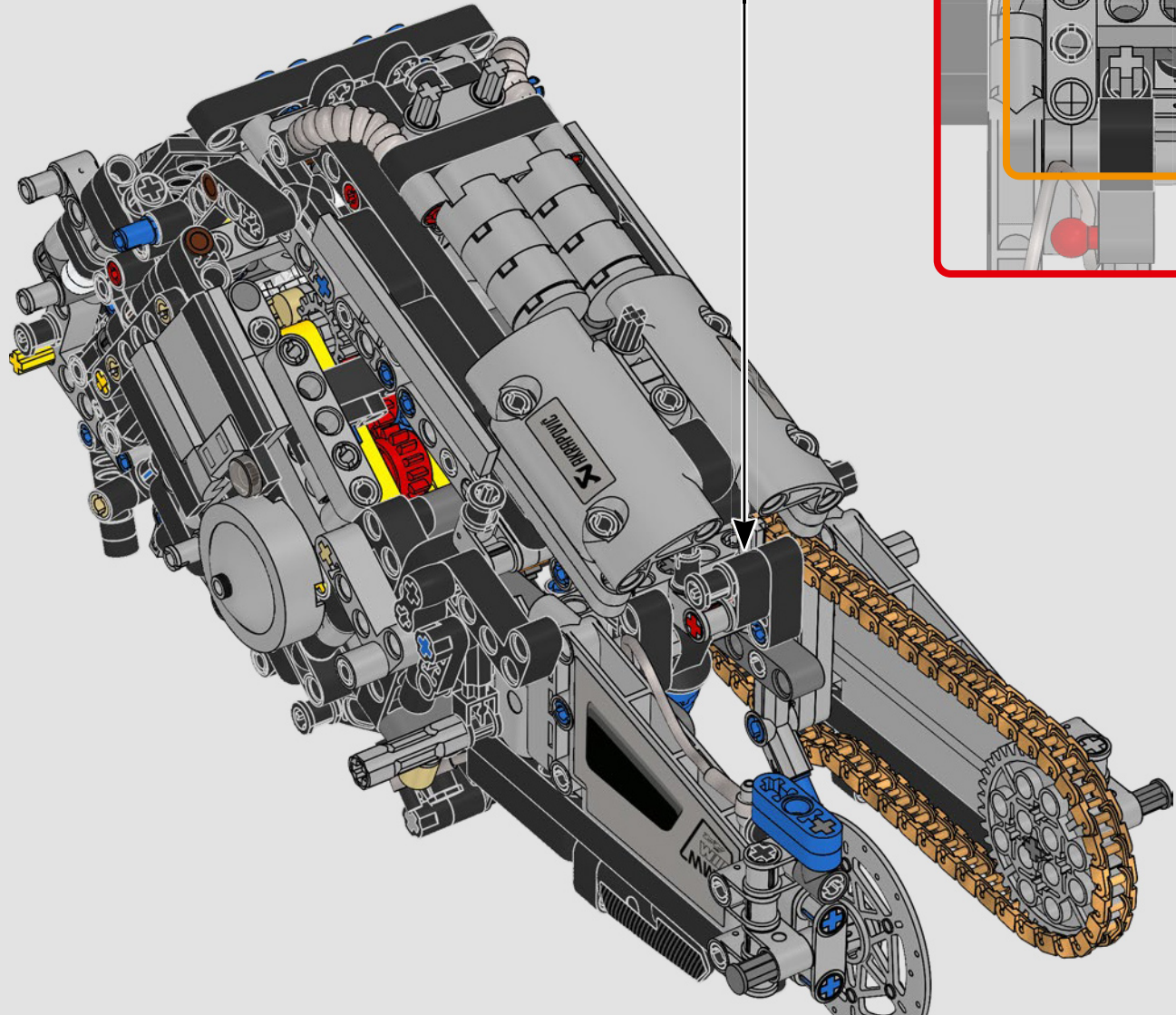
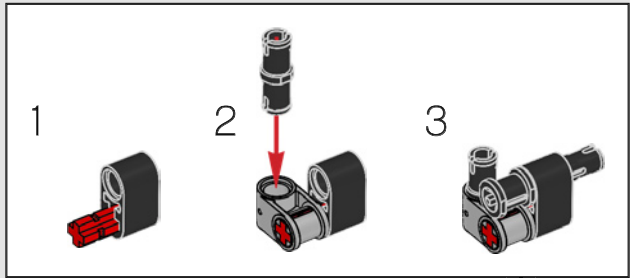

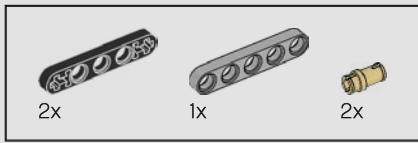

323

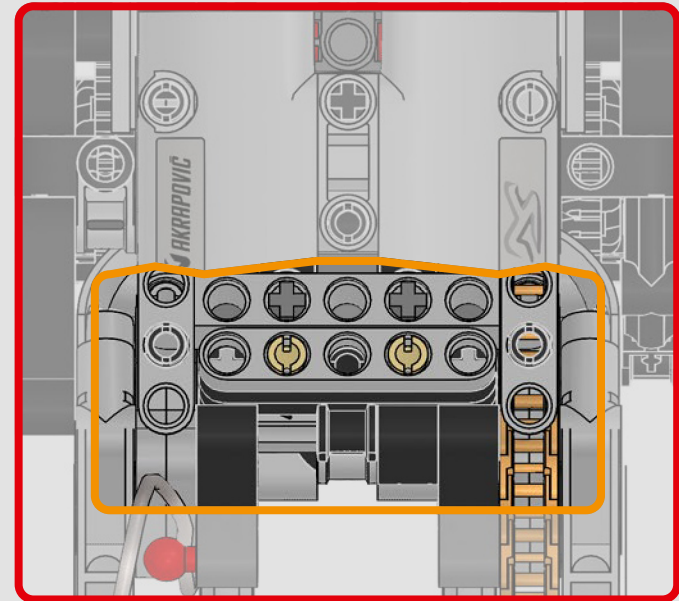
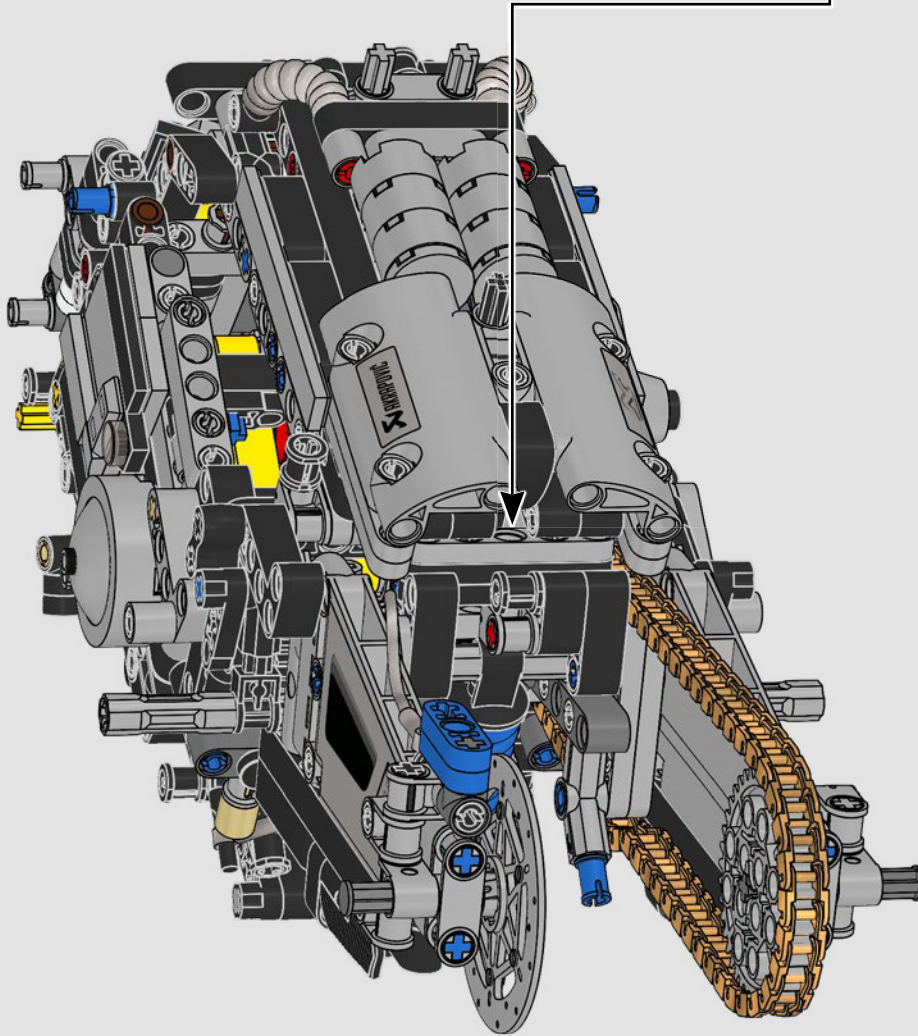
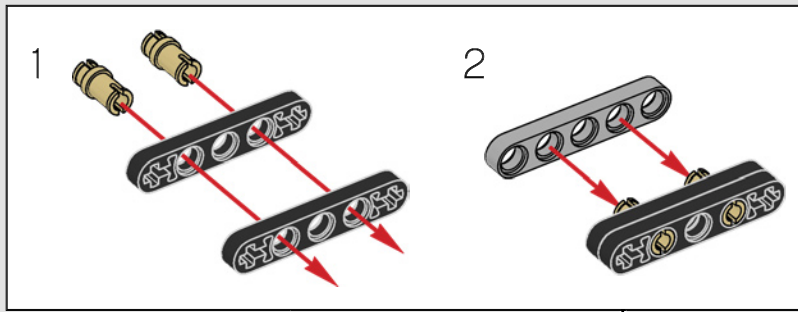

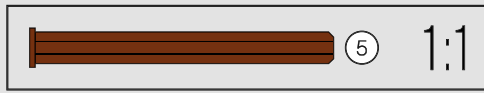
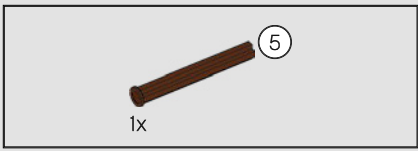

324

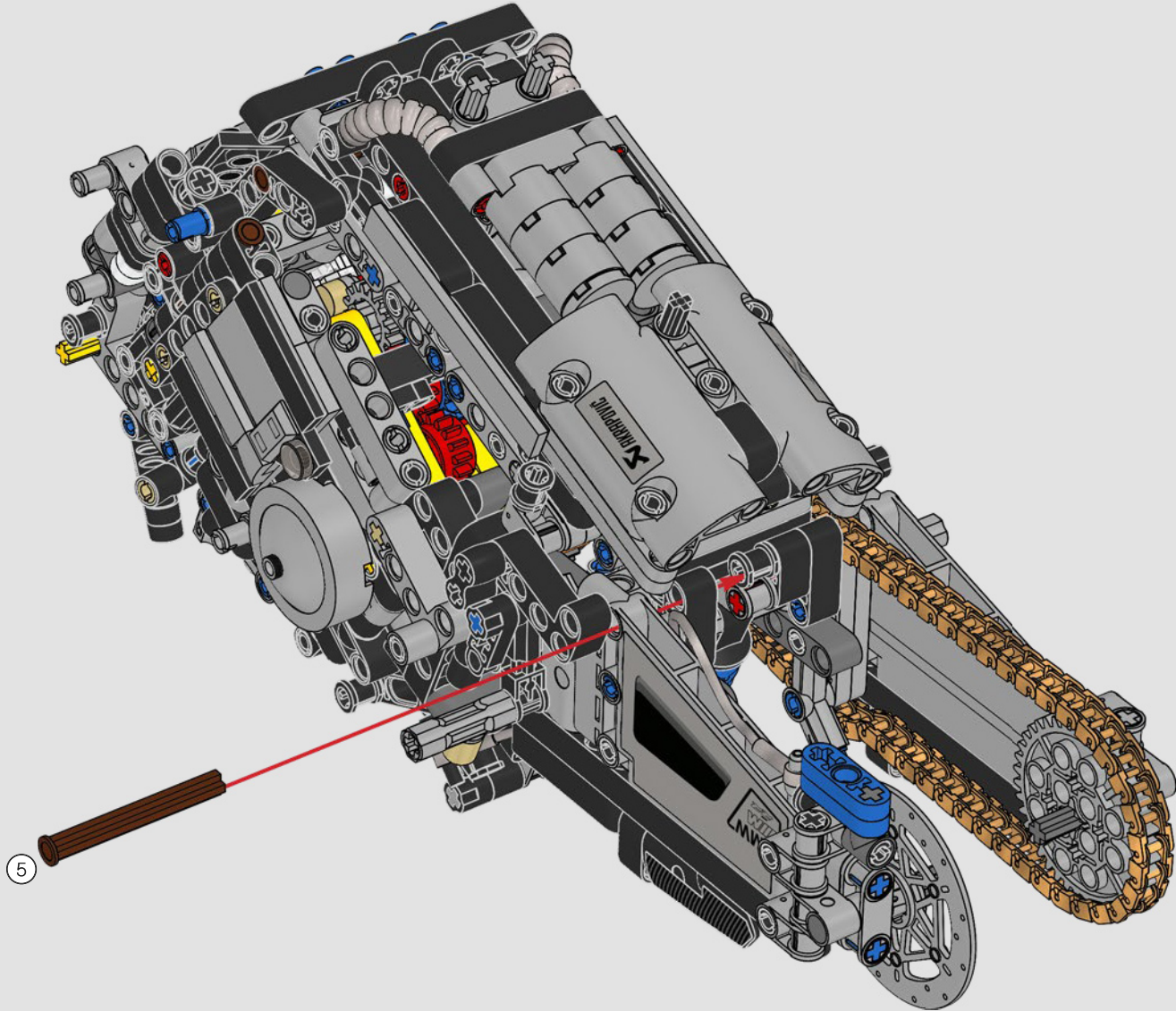

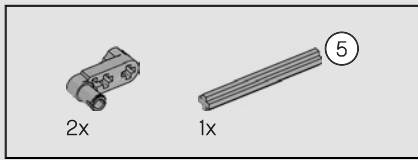

325

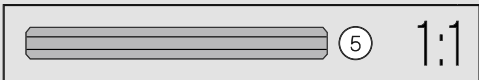
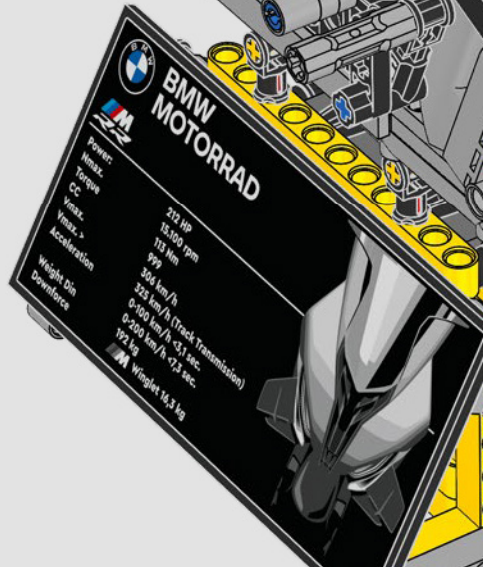
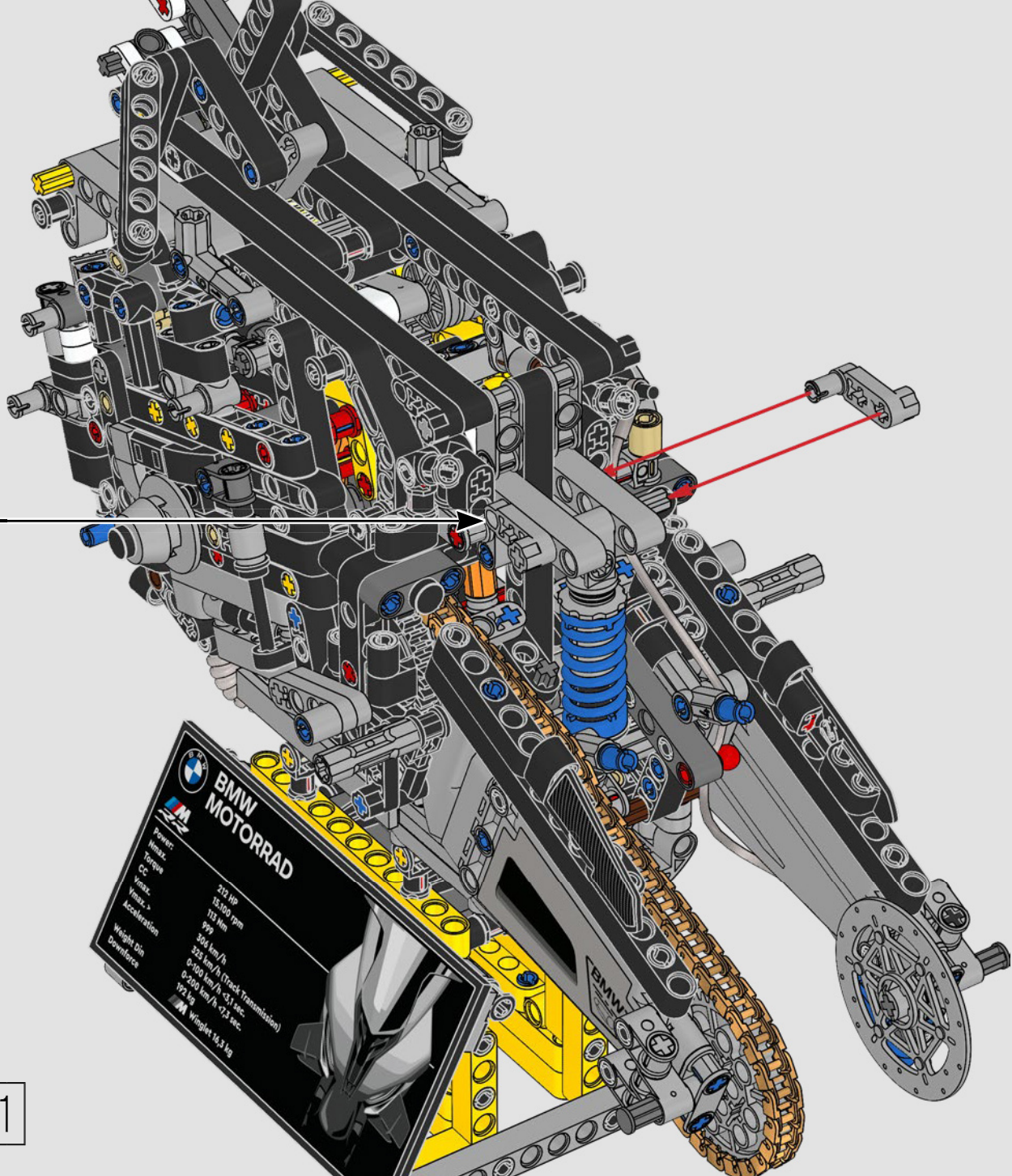
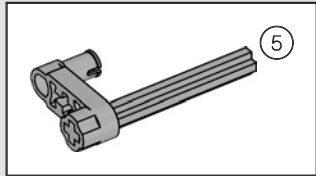

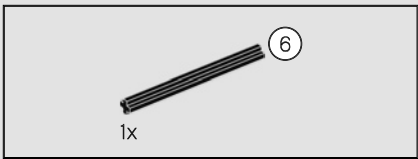

326

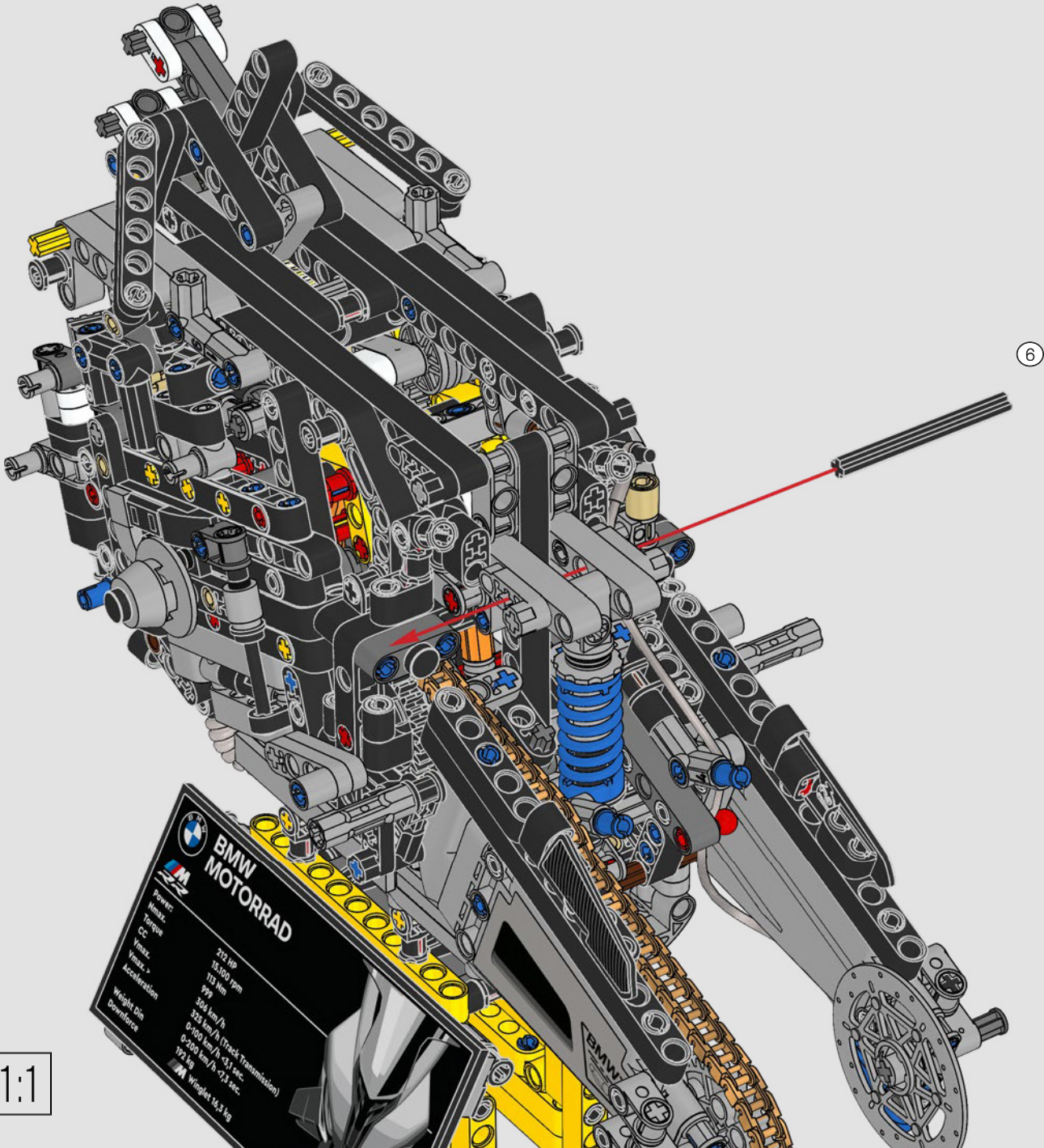

BMW MOTORRAD

Power	212 HP
Max. torque	15,100 Nm
CC	113 Nm
v _{max}	99
v _{max} +	304 km/h
Acceleration	323 km/h (Track transmission)
Weight (Dry)	0-100 km/h < 3.1 sec.
Downforce	0-200 km/h < 7.1 sec.
	172 kg
	Weight 14.3 kg

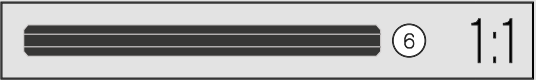

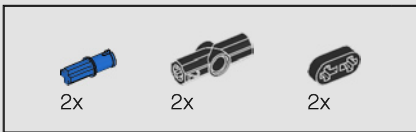

327

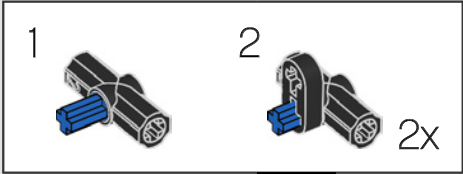
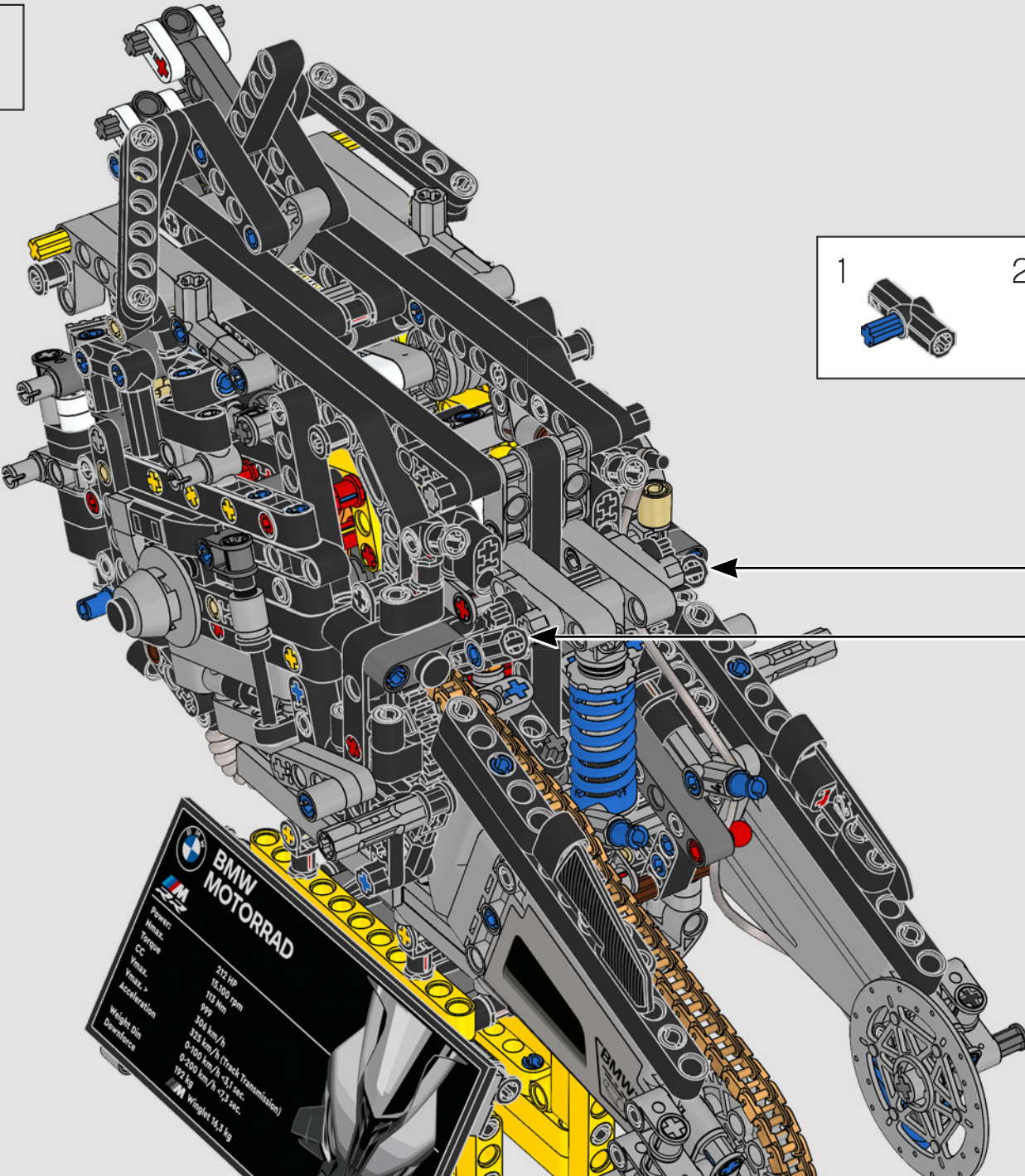

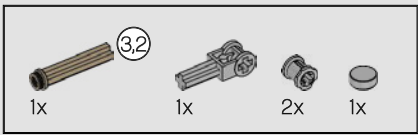

328

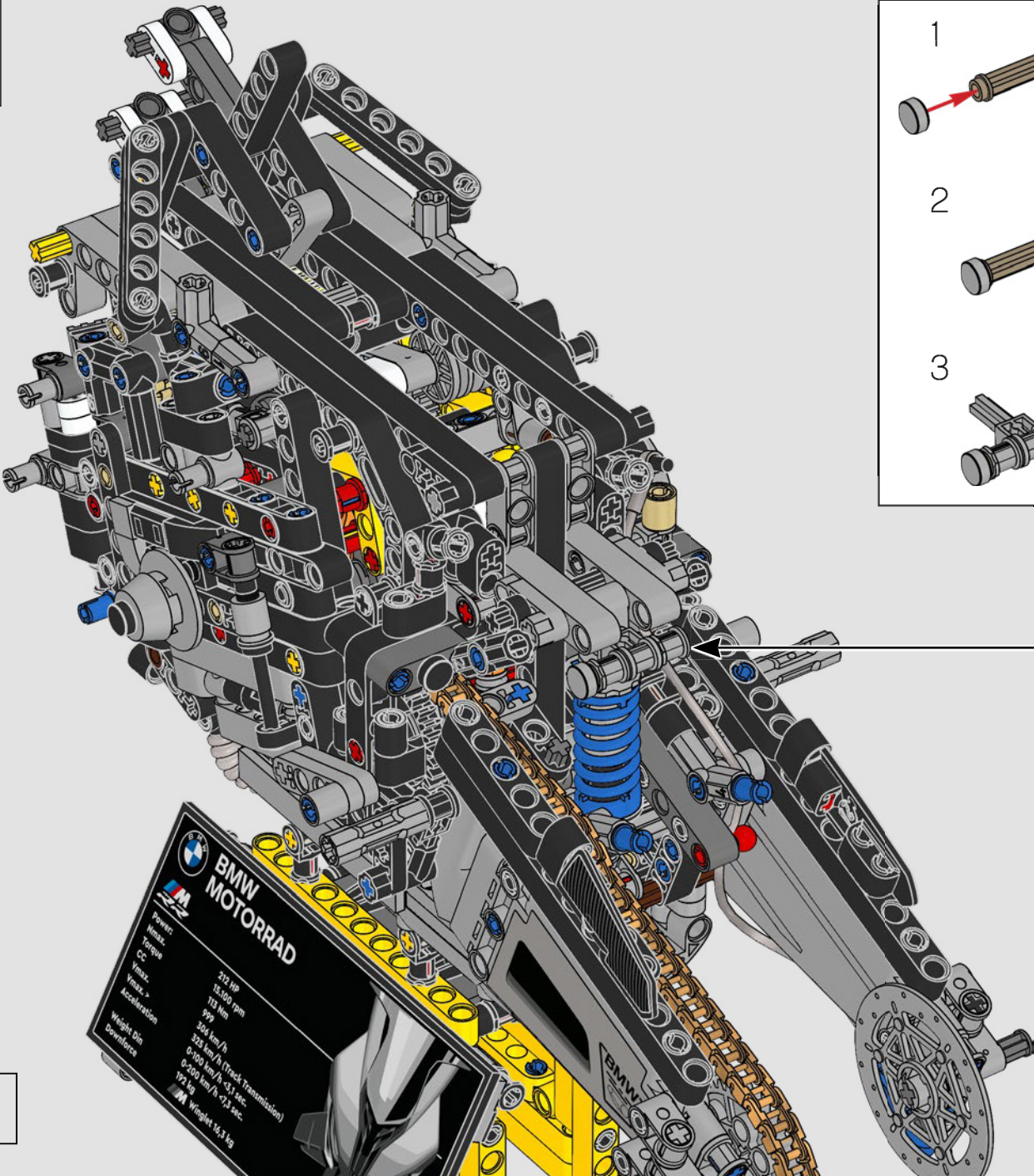
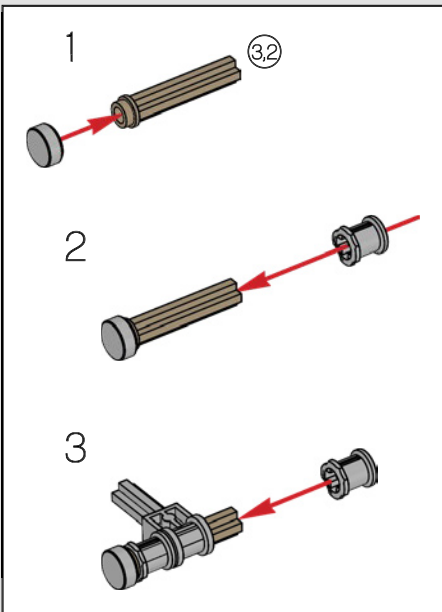

BMW MOTORRAD

Power	212 hp
Max. Torque	15.100 rpm
CC	113 cm ³
v _{max}	599 km/h
v _{max} >	304 km/h
Acceleration	0-100 km/h: 0,3 sec.
Weight (Dry)	192 kg
Downforce	192 kg

Weight 16,3 kg

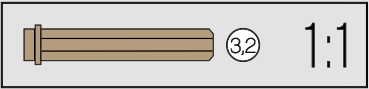

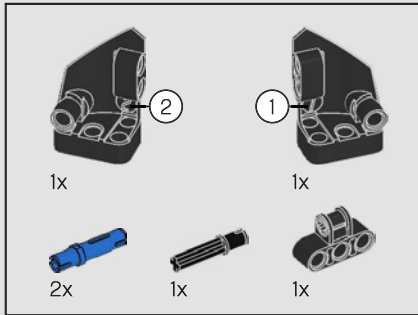

329

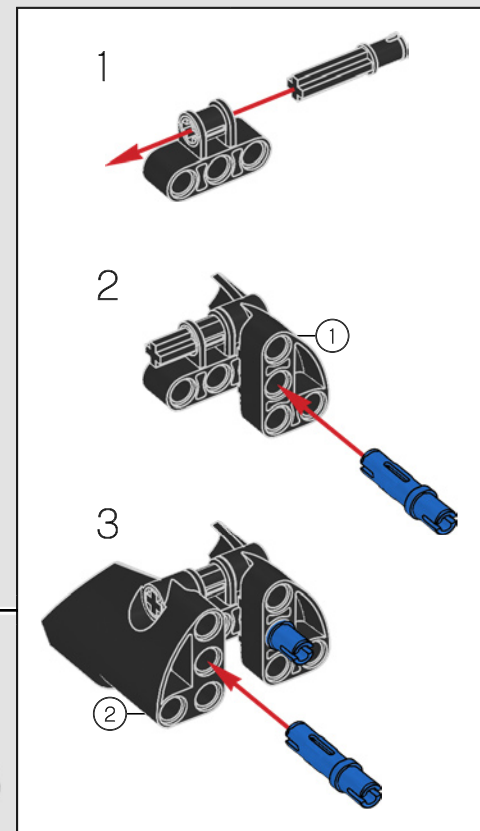
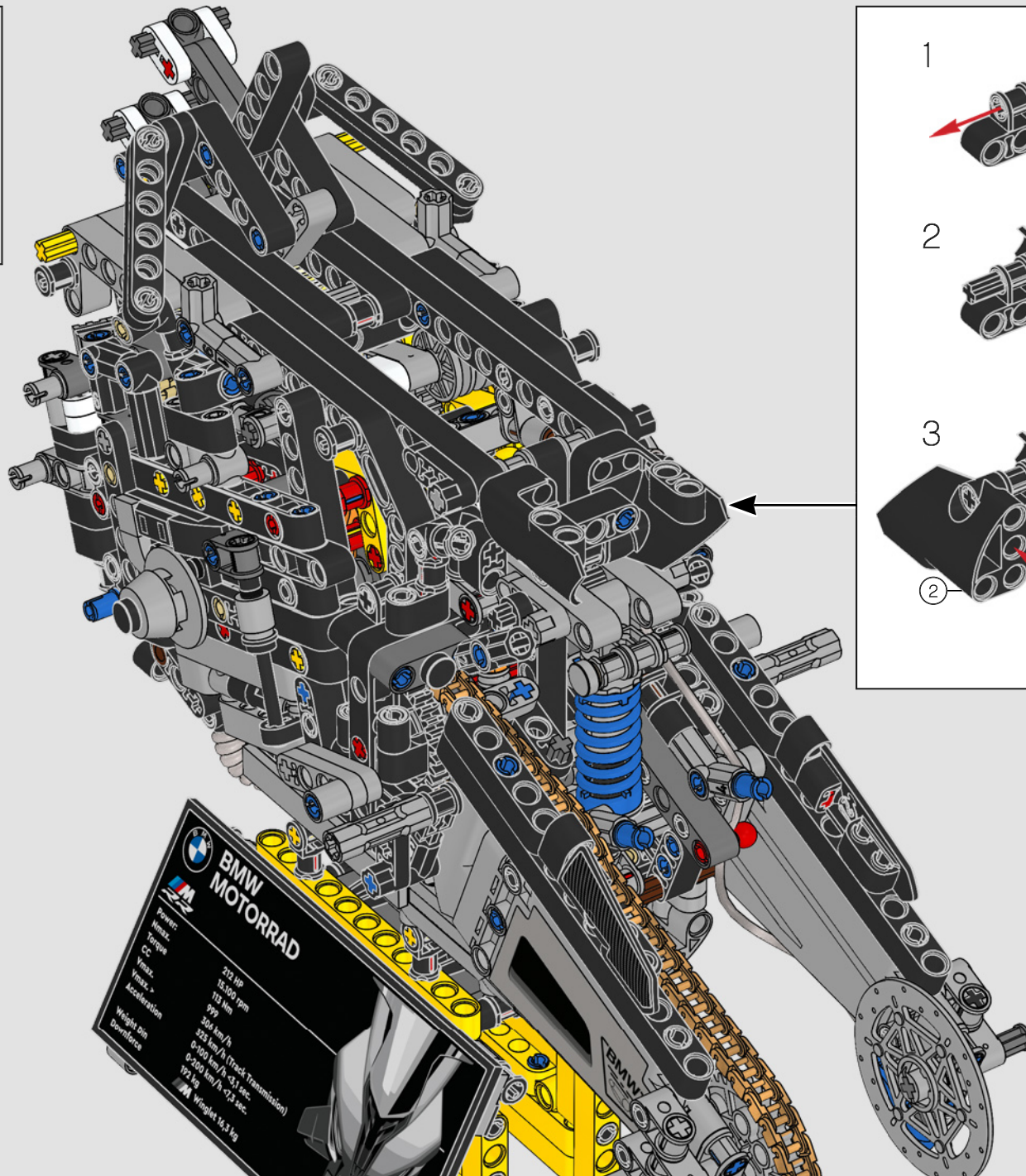

BMW MOTORRAD	
Power:	210 HP
Horsepower:	15,100 rpm
Torque:	112 Nm
CC:	999
0-100 km/h:	3.04 sec
0-200 km/h (Track Transmission):	9.100 sec
Acceleration:	0-200 km/h \approx 1.73 sec
Weight (Dry):	172 kg
Weight (Wet):	163 kg

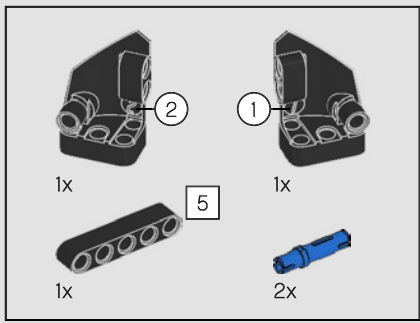

330

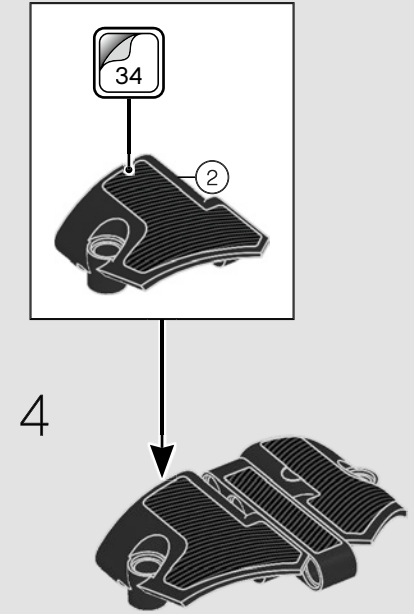
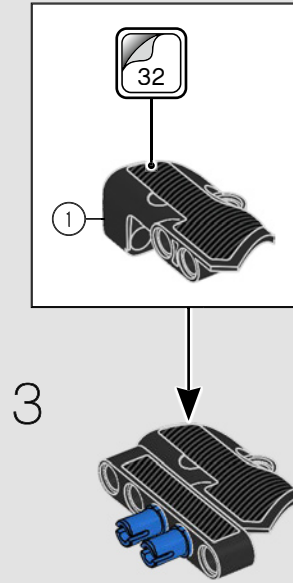
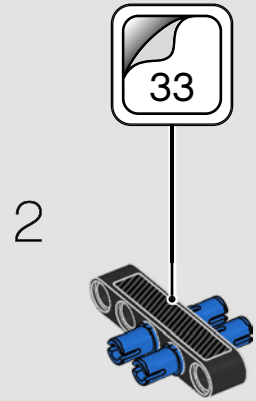
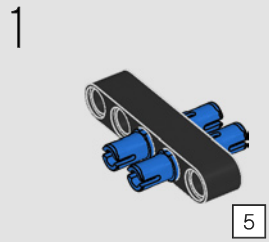

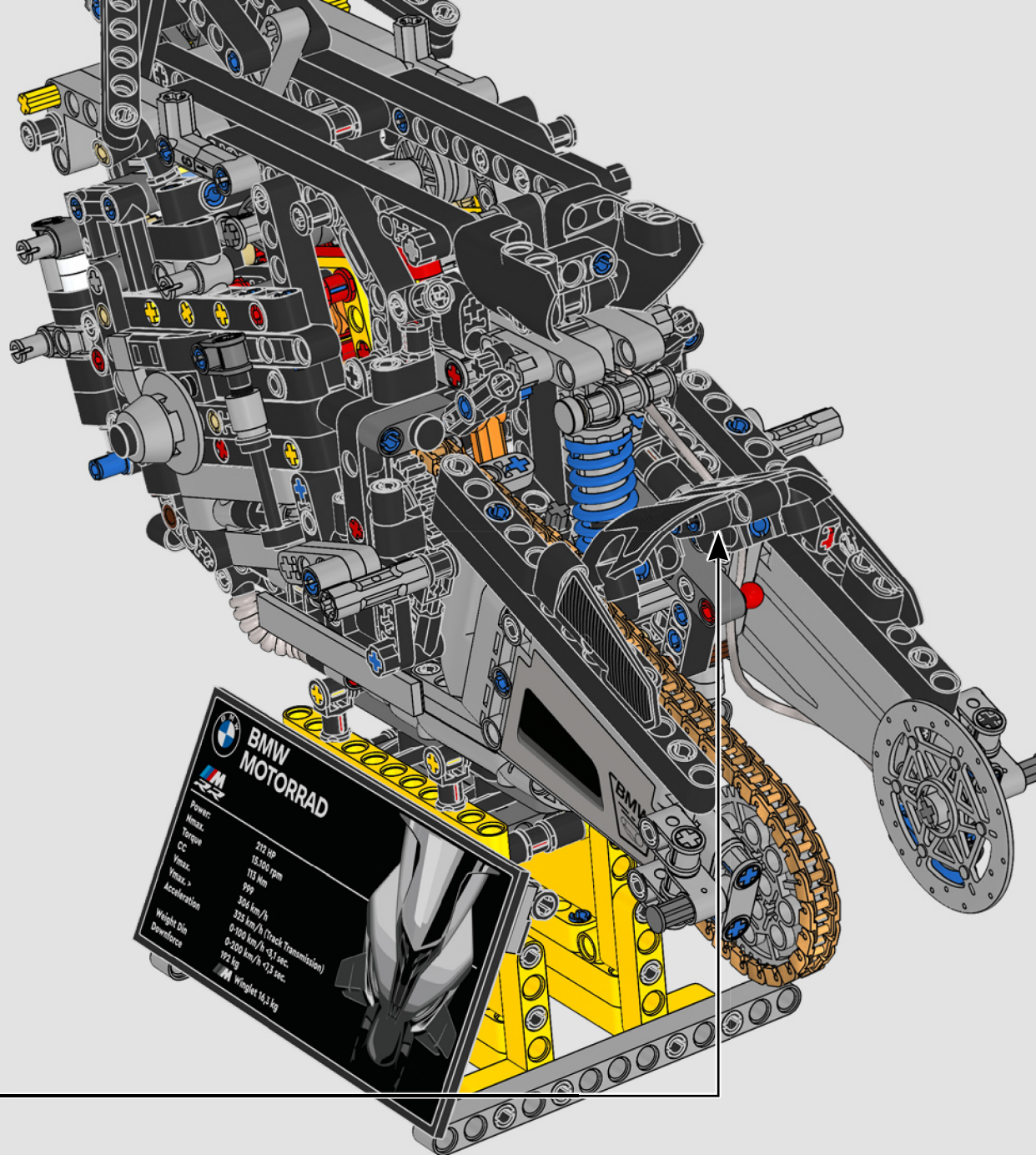

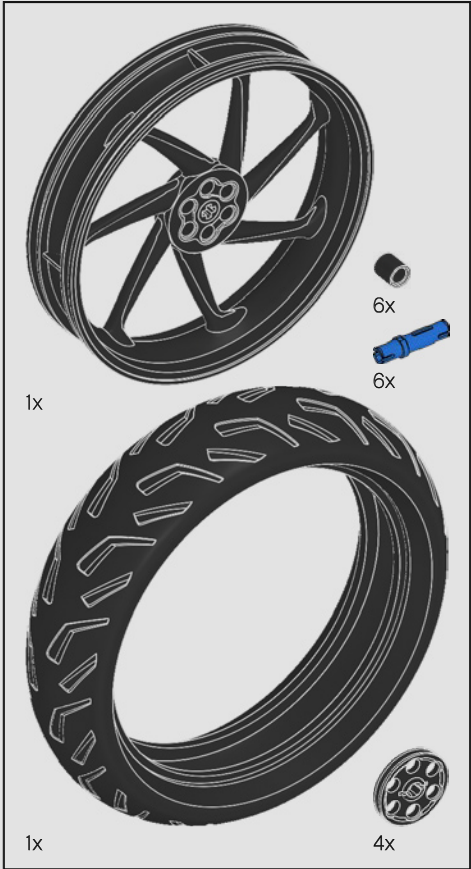

1

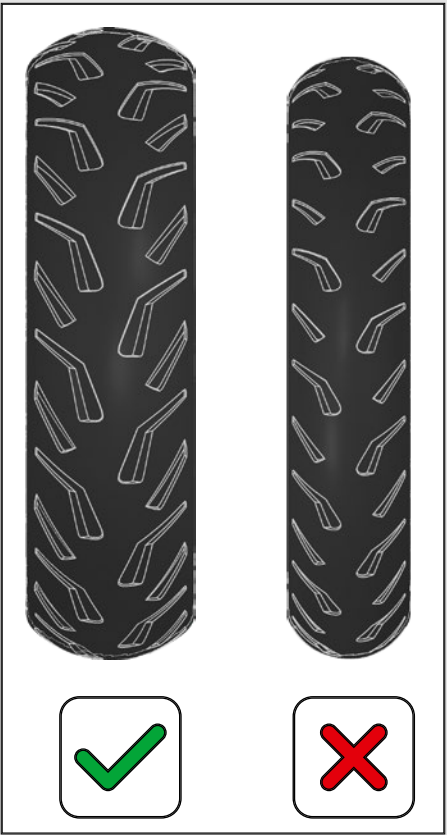

331

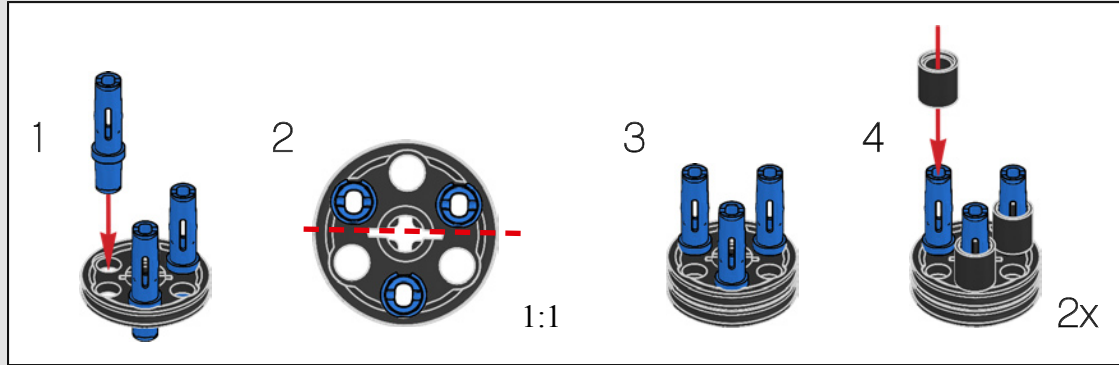

2

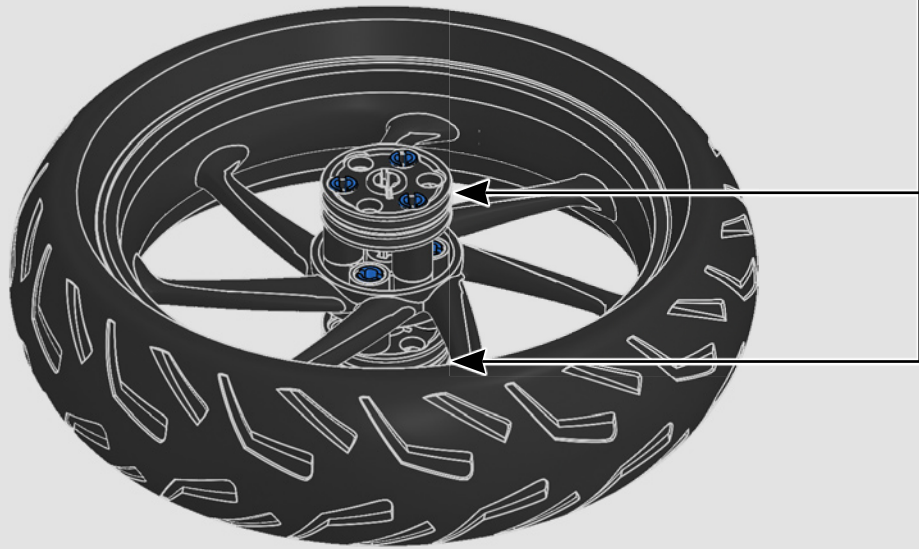

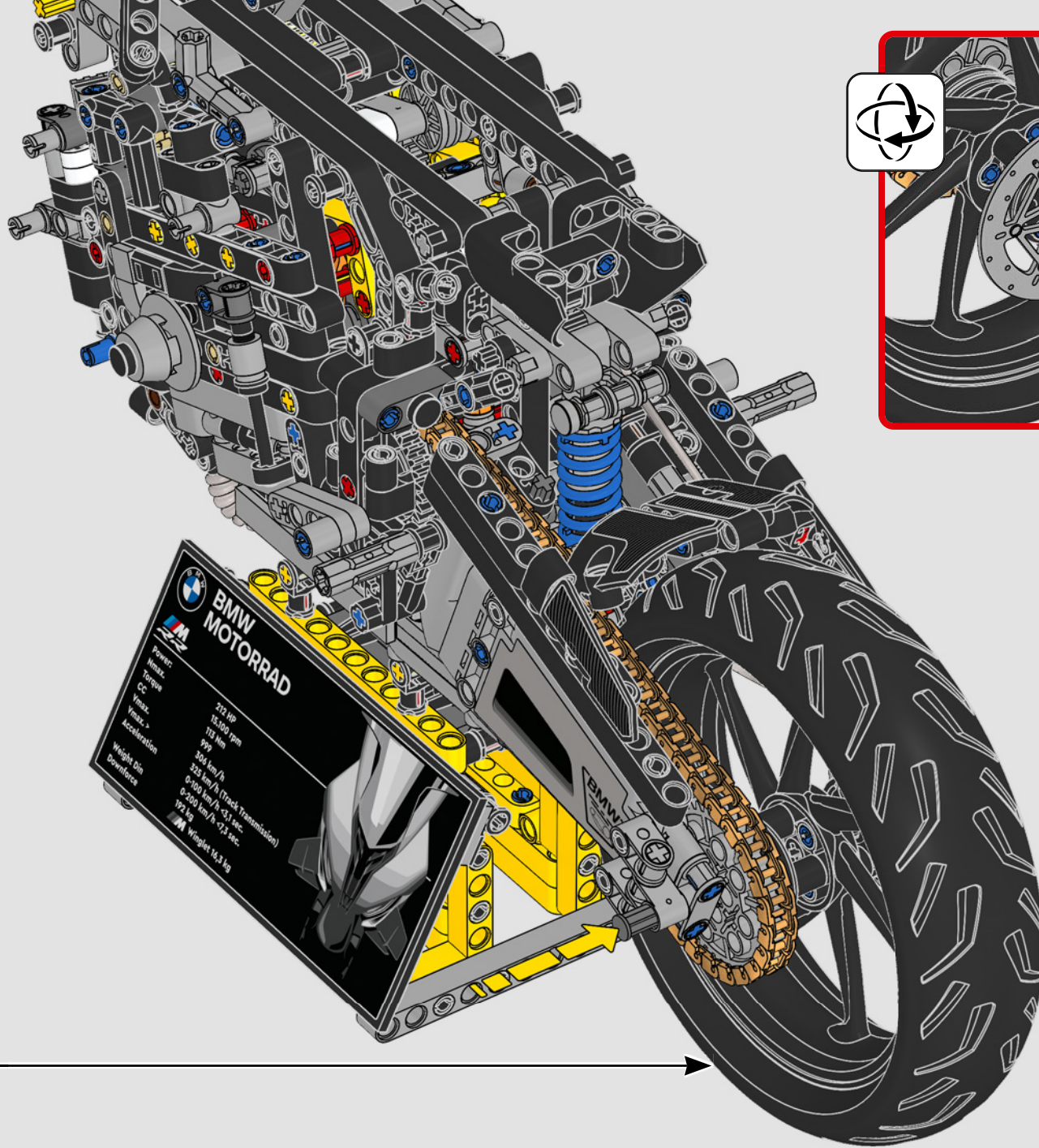

BMW MOTORRAD

Power:	212 hp
Torque:	15,100 rpm
CC:	113 cm
Vmax:	306 km/h
Vmax >	325 km/h (Track Transmission)
Acceleration:	0-200 km/h < 3.1 sec.
Weight Dry:	172 kg
Weight Full:	193 kg

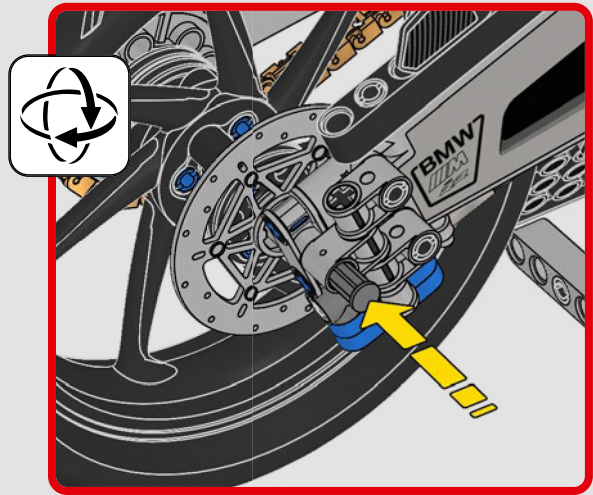

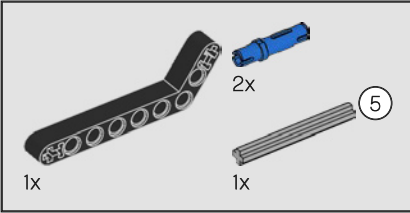
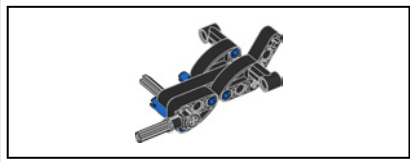

332

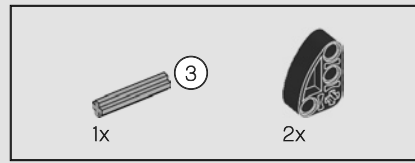
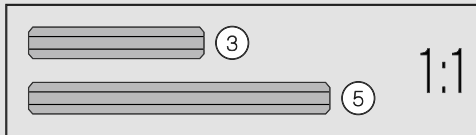
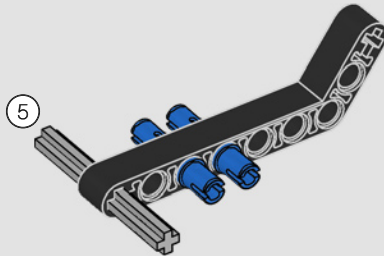

333

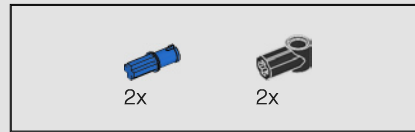
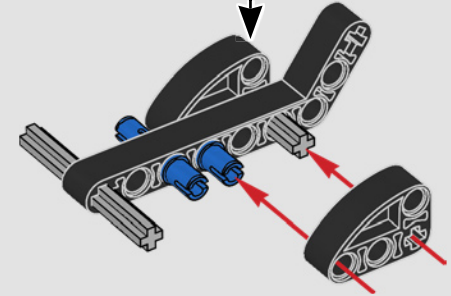
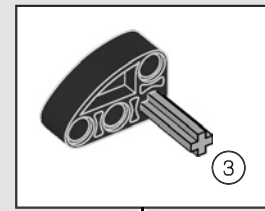

334

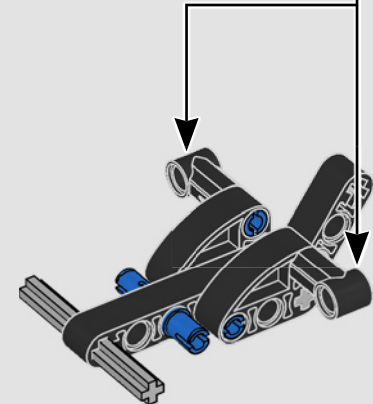
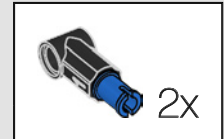

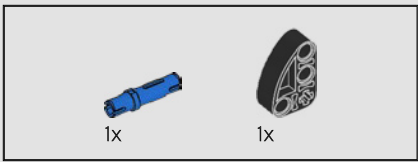

335

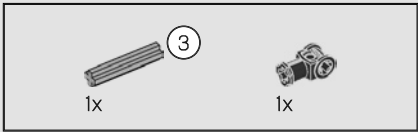
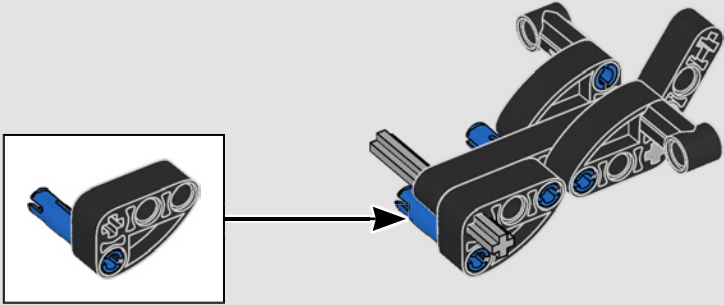

336

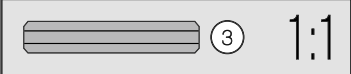
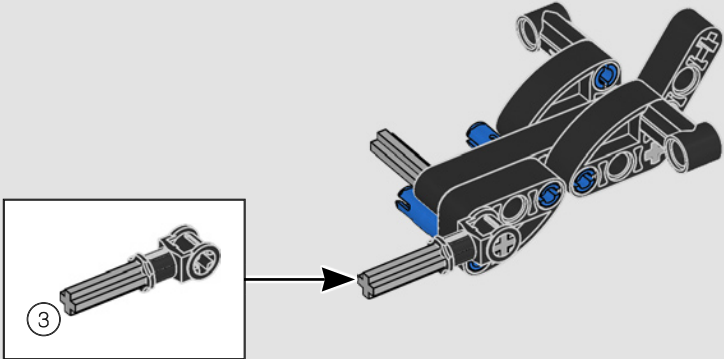

337

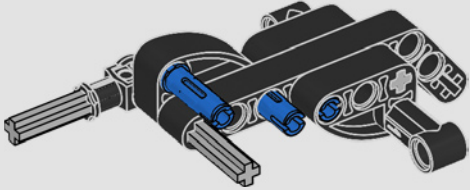

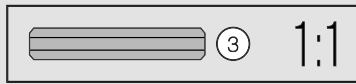
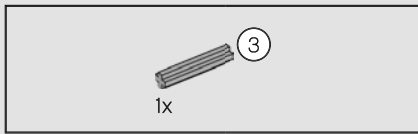

338

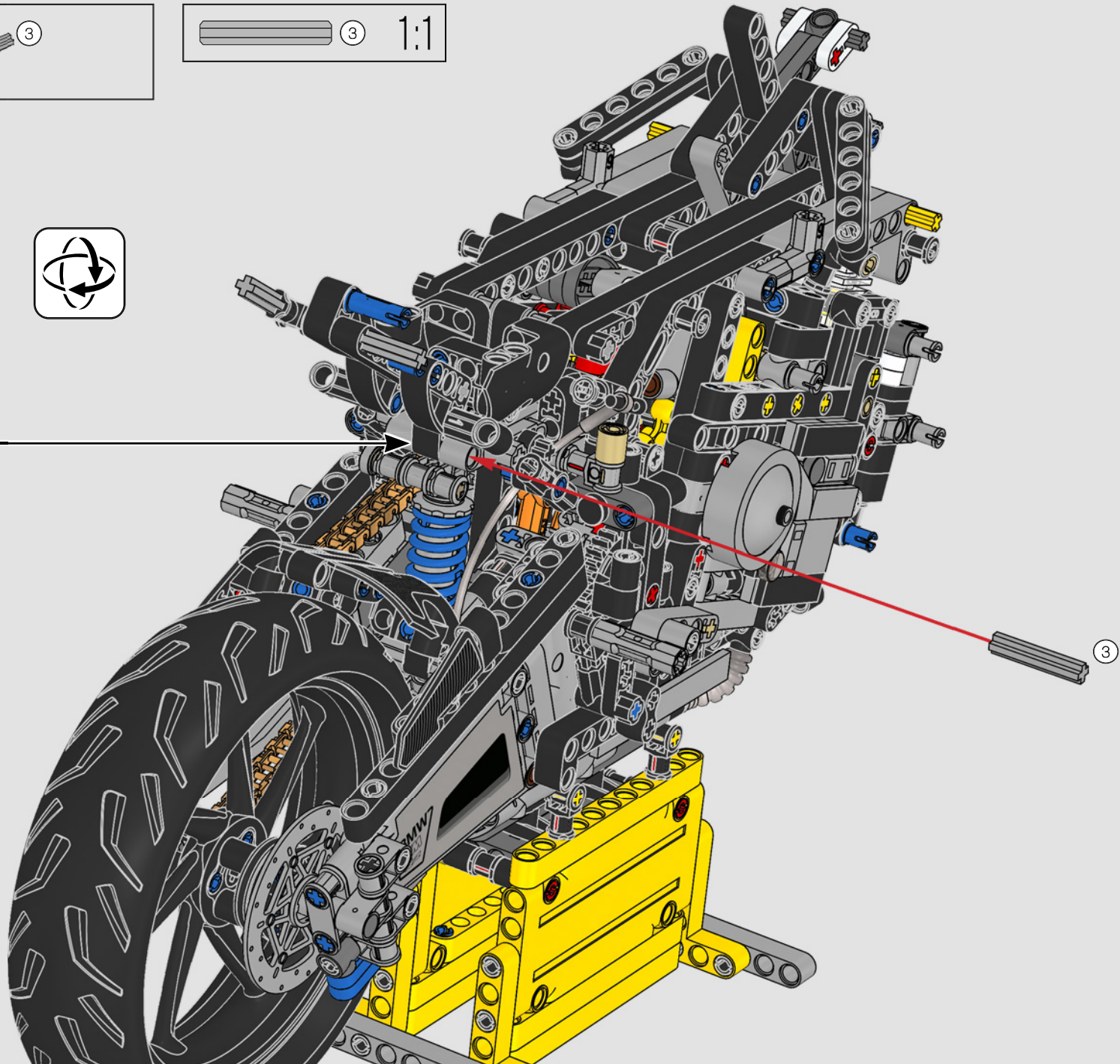

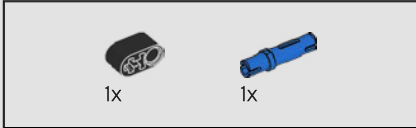
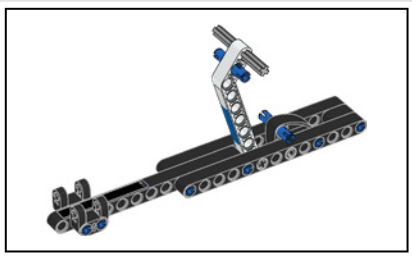

339

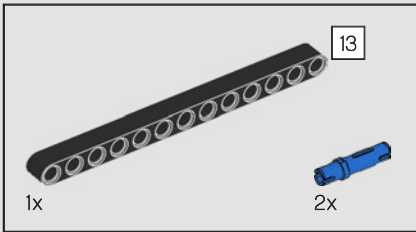

340

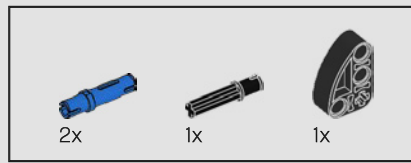
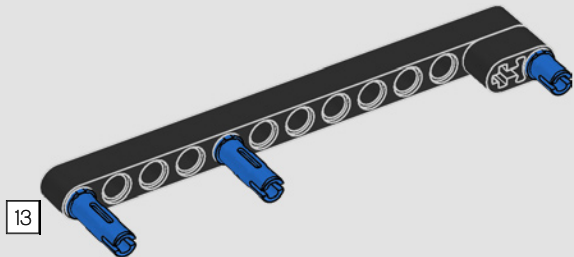

341

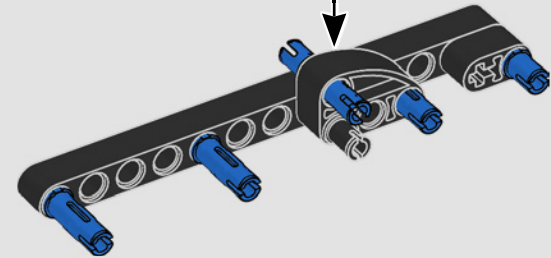
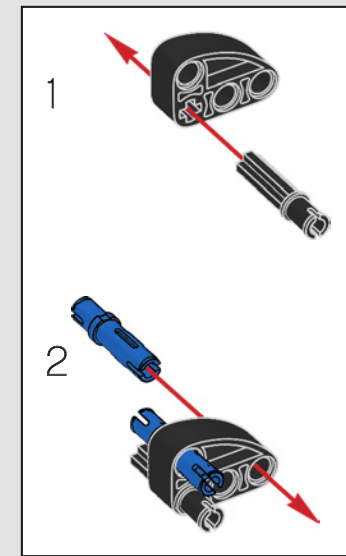

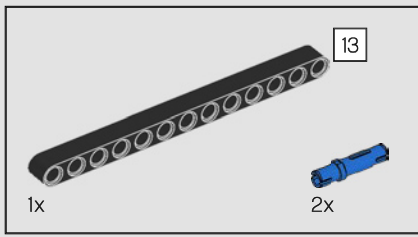

342

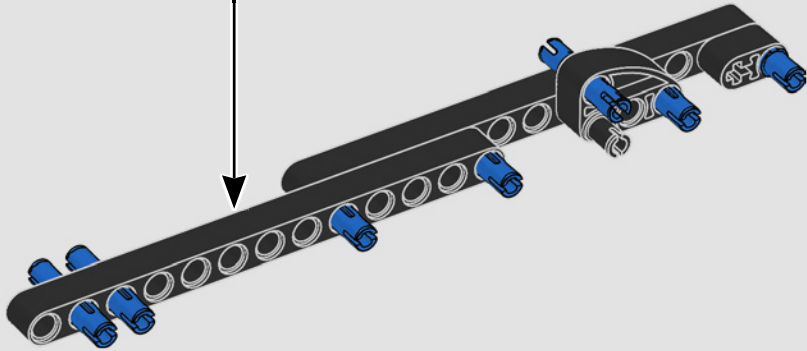
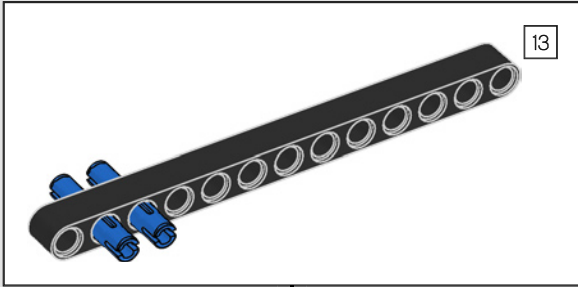

343

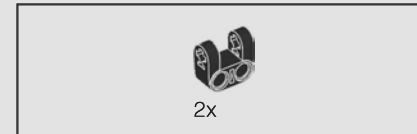
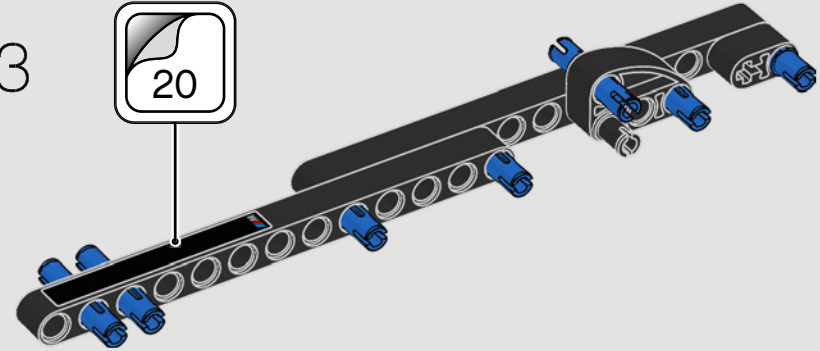

344

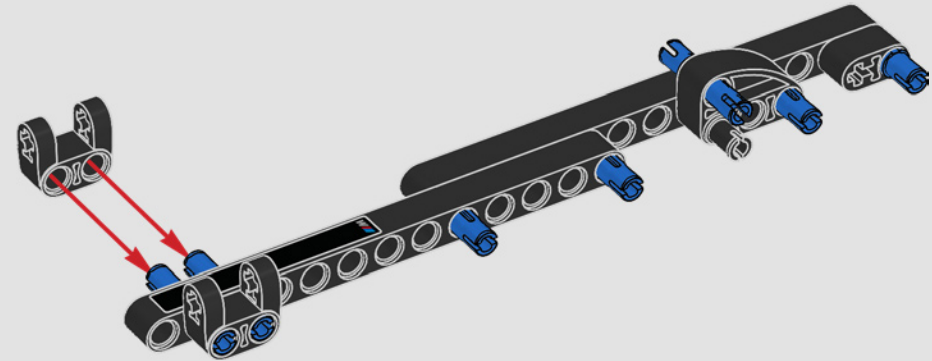

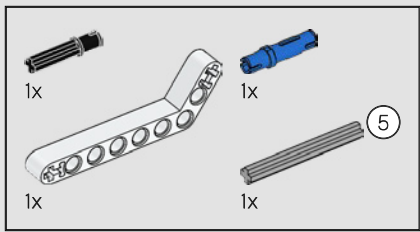

345

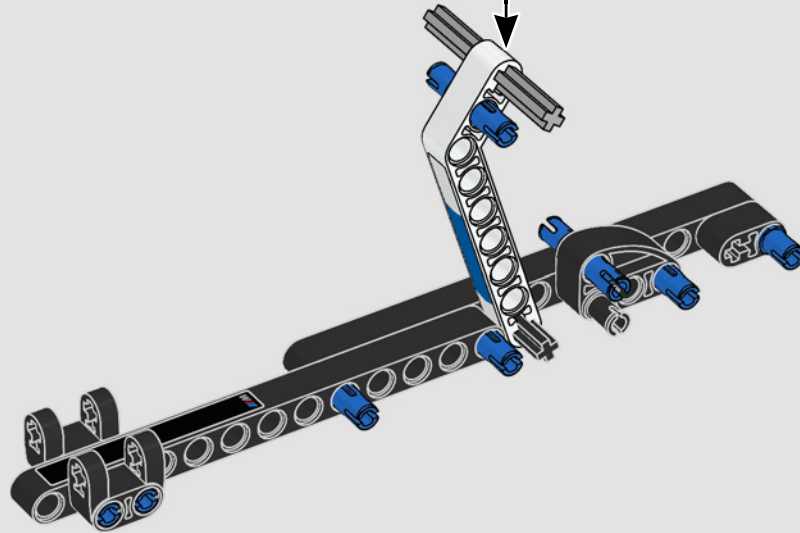
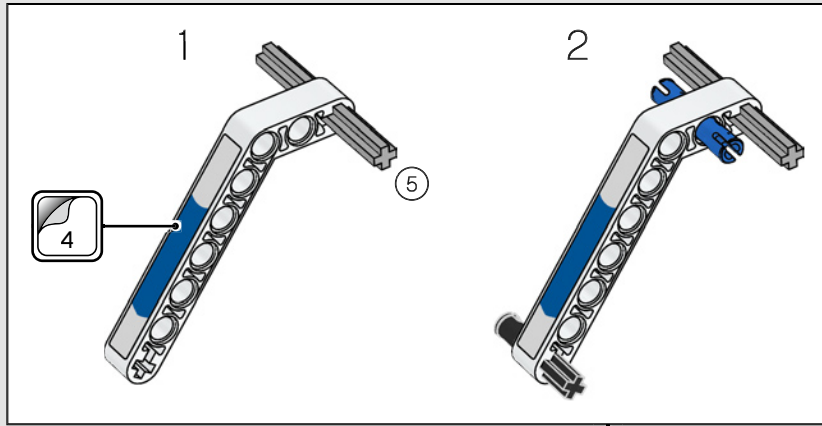
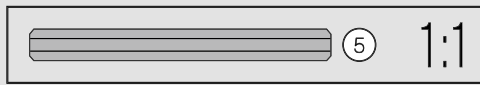

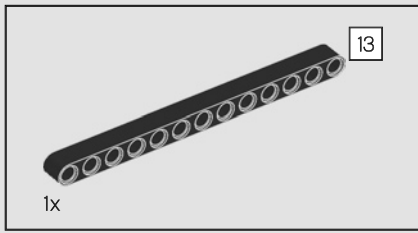

346

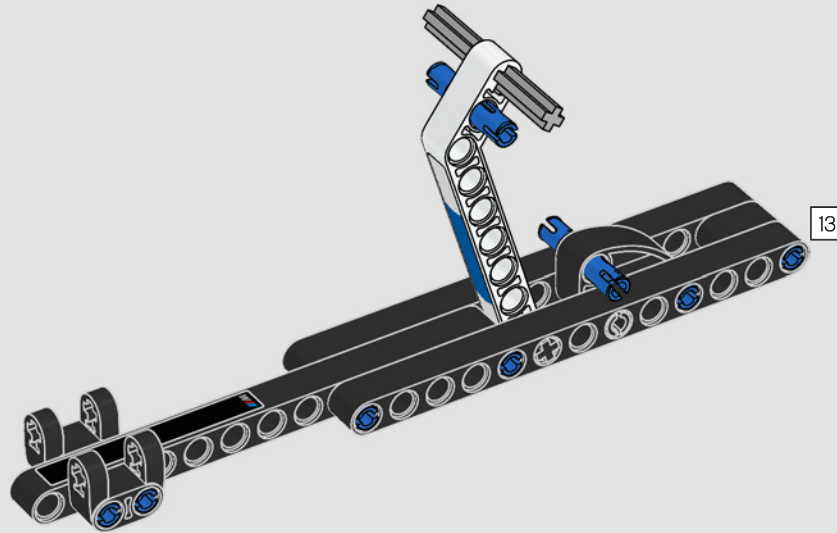

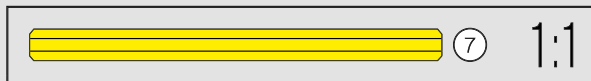
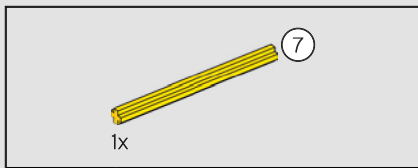

347

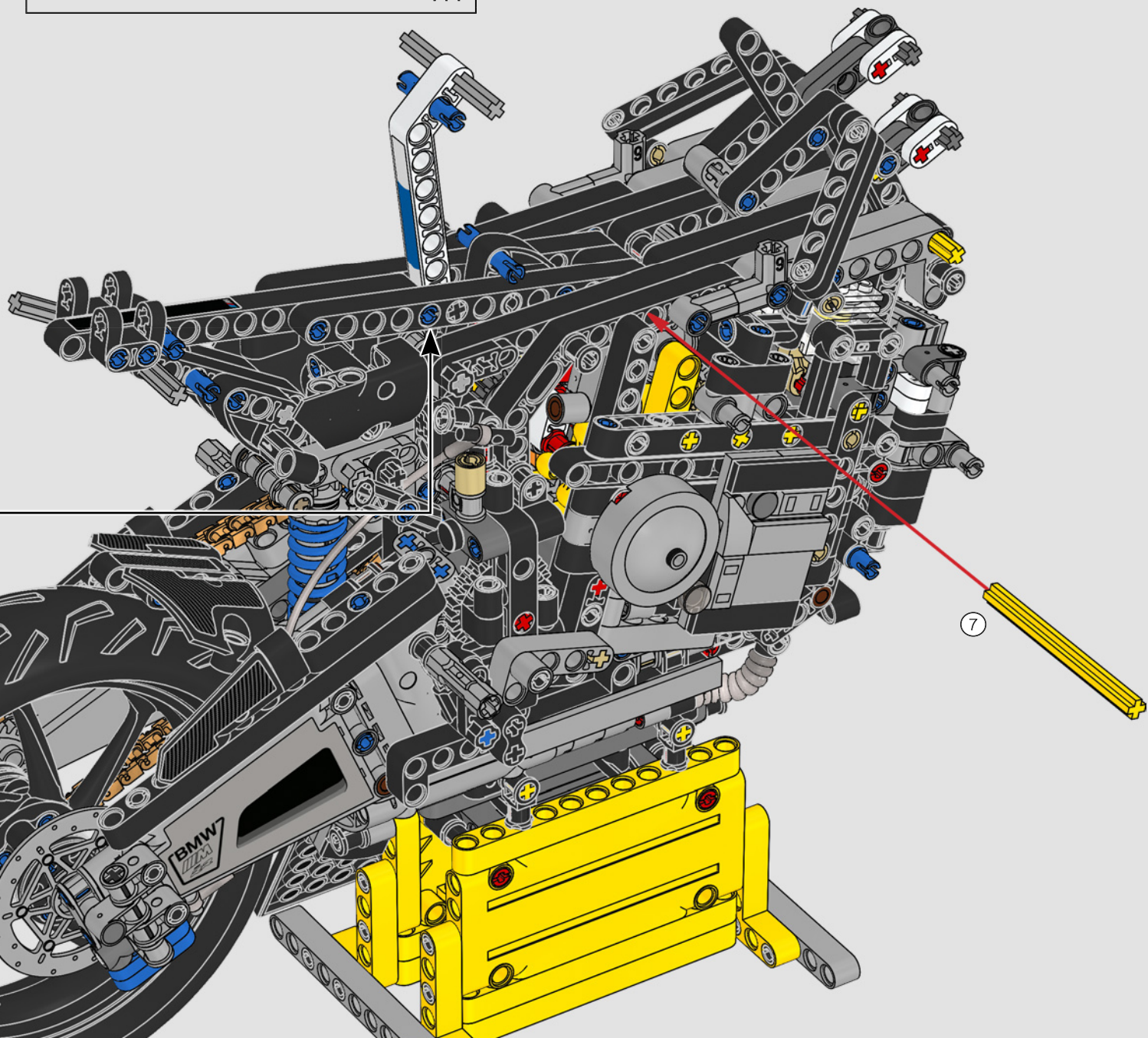
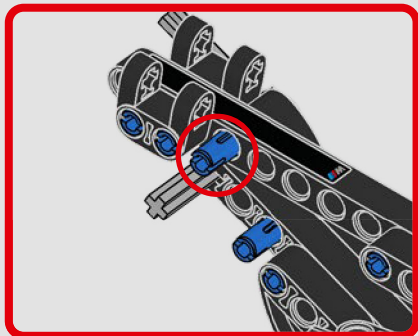

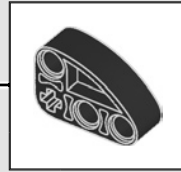
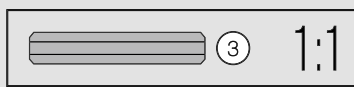

348

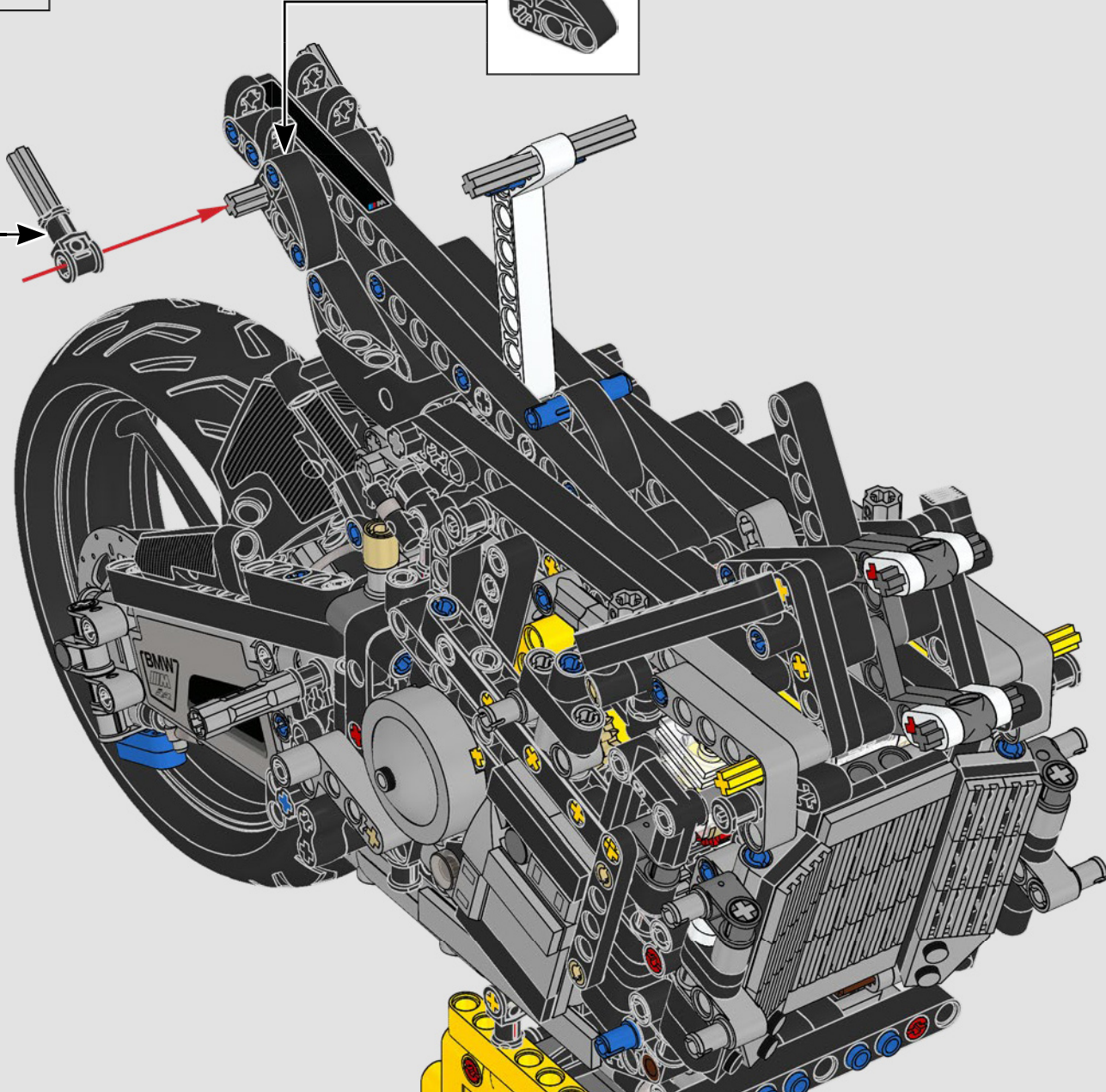
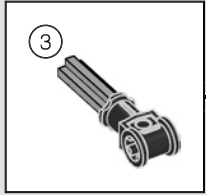



2x

349

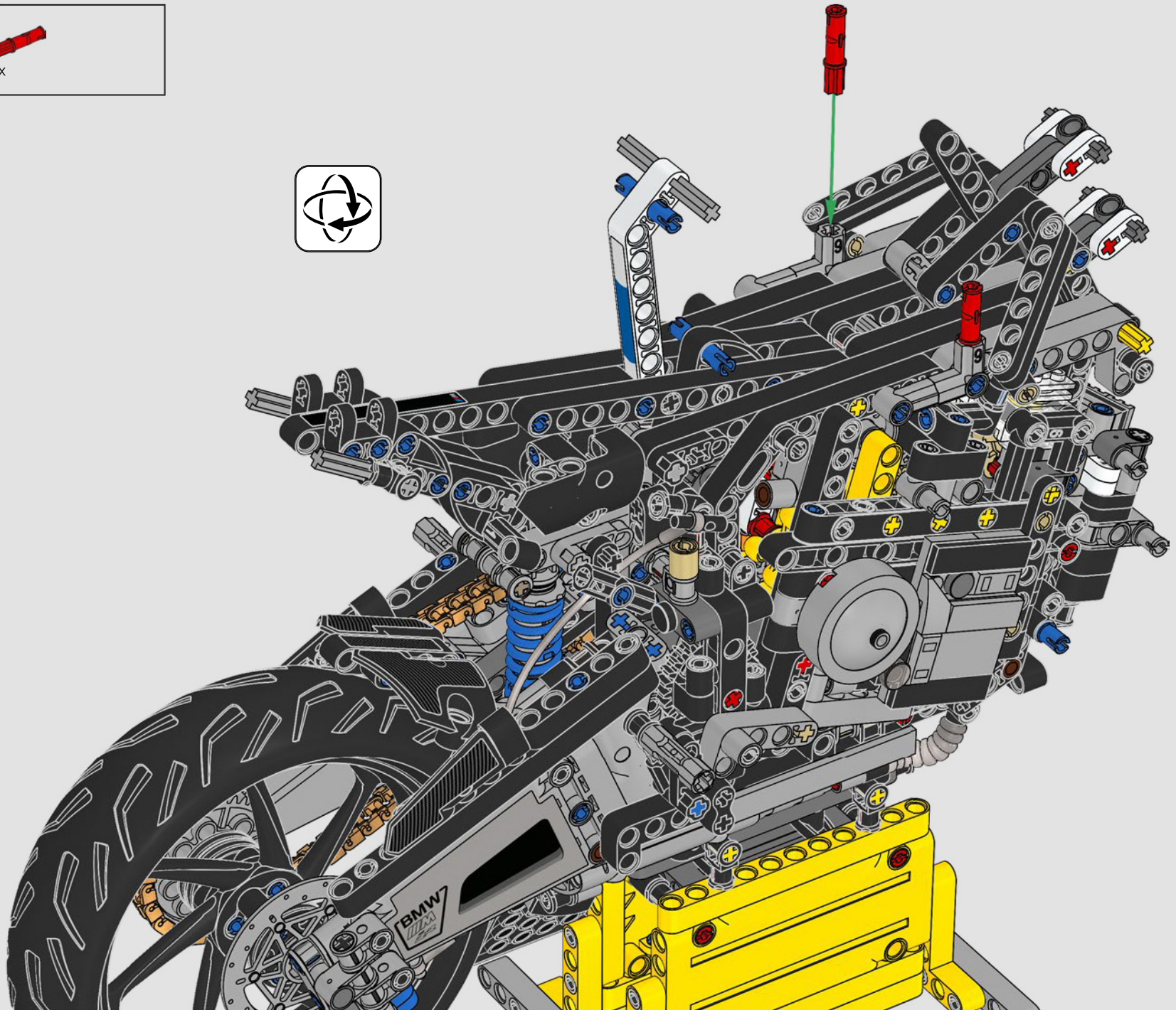

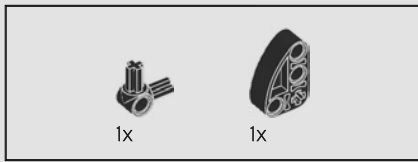

350

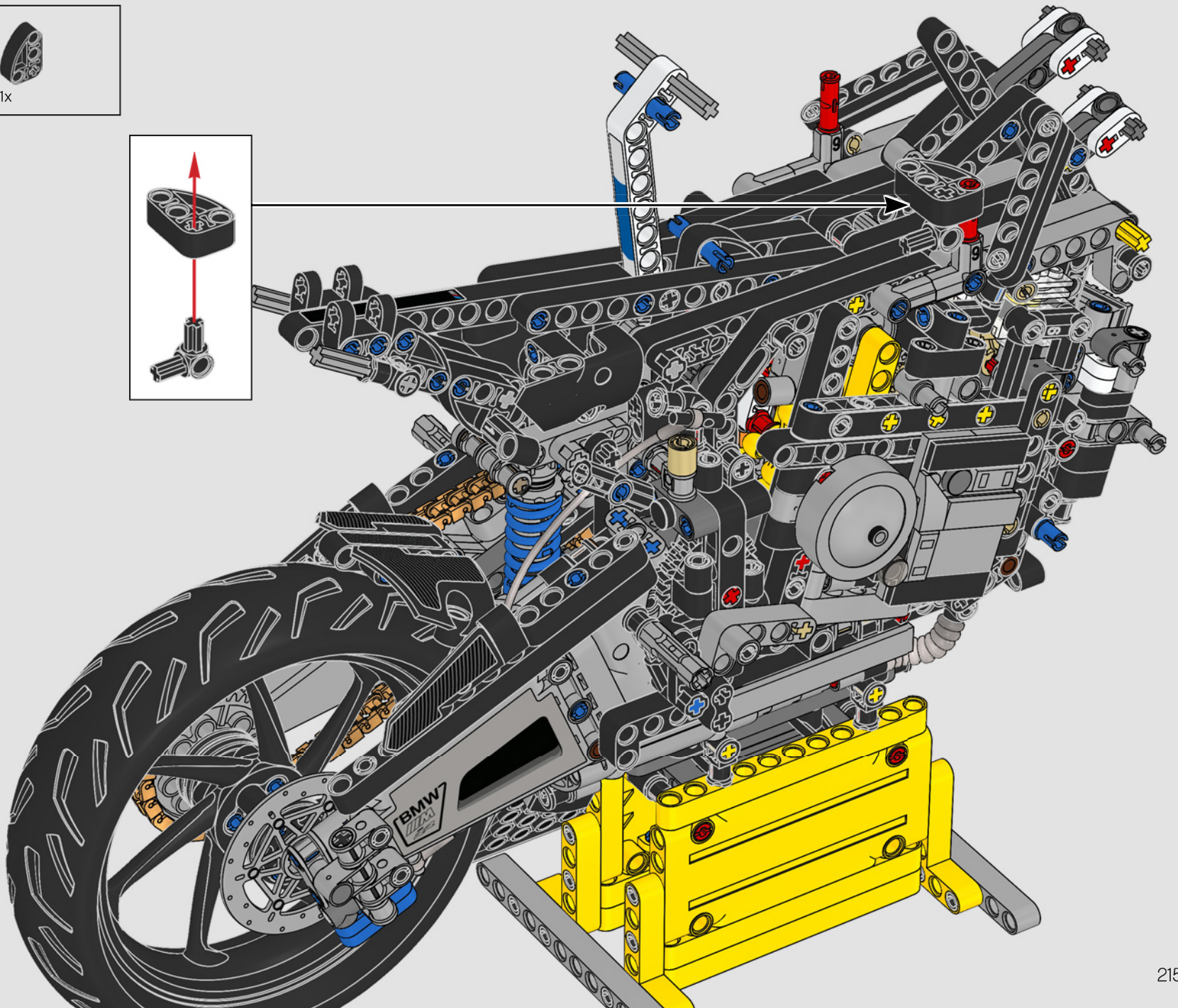
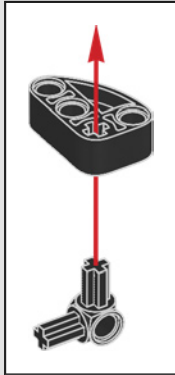

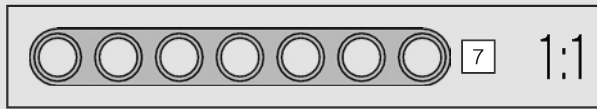
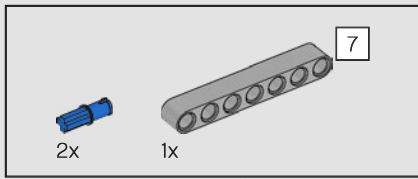

351

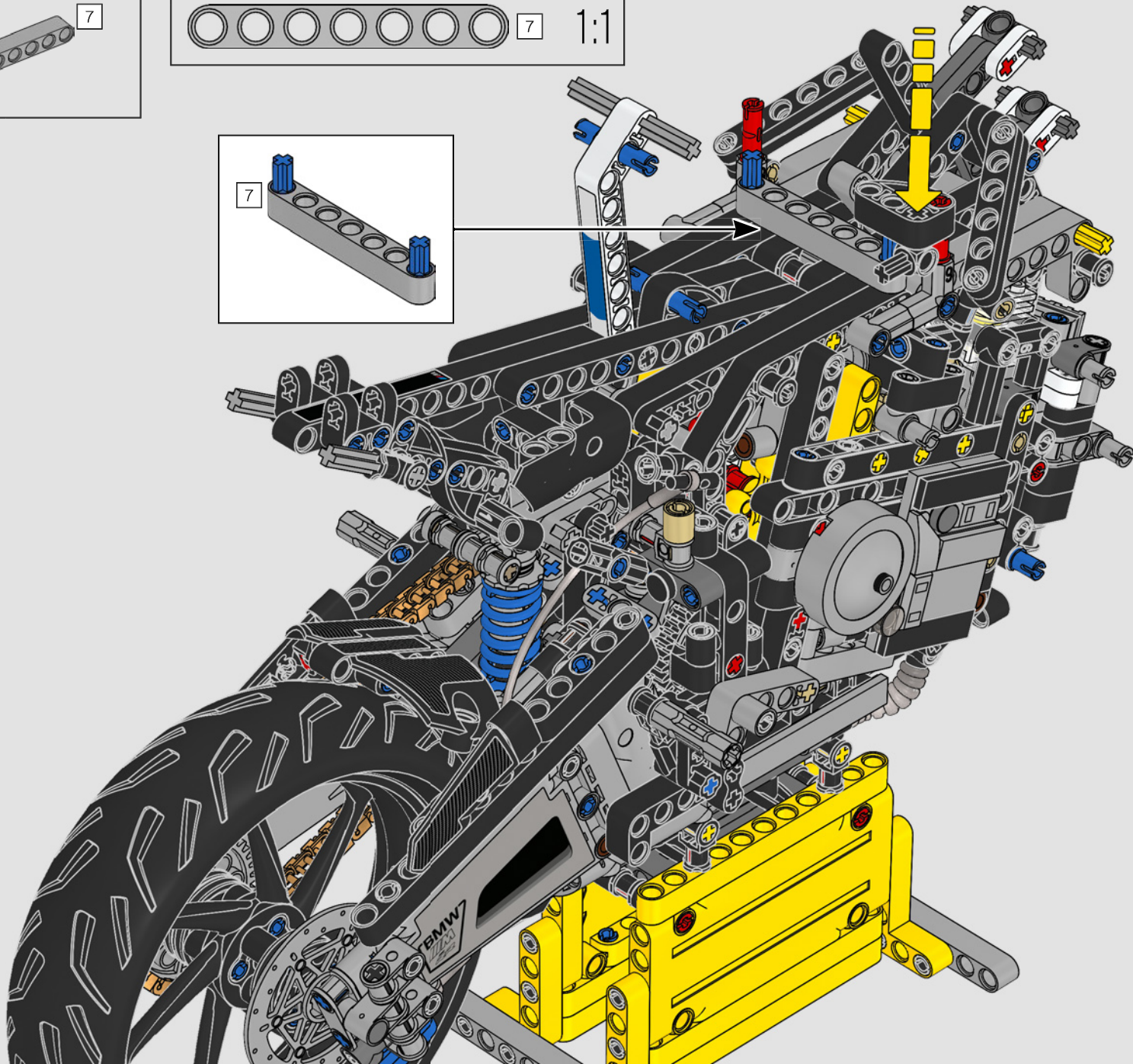
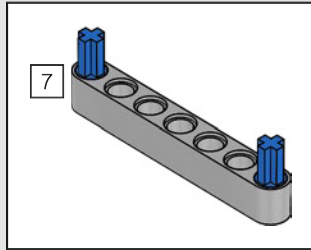

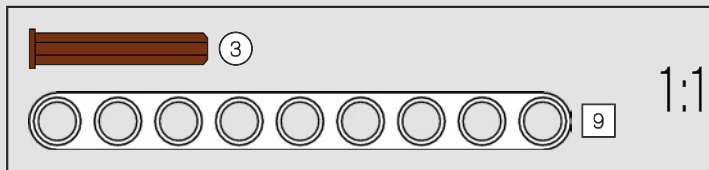
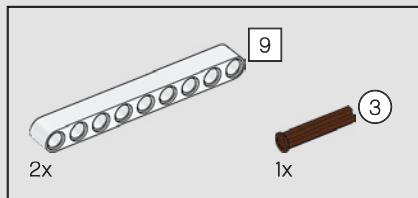

352

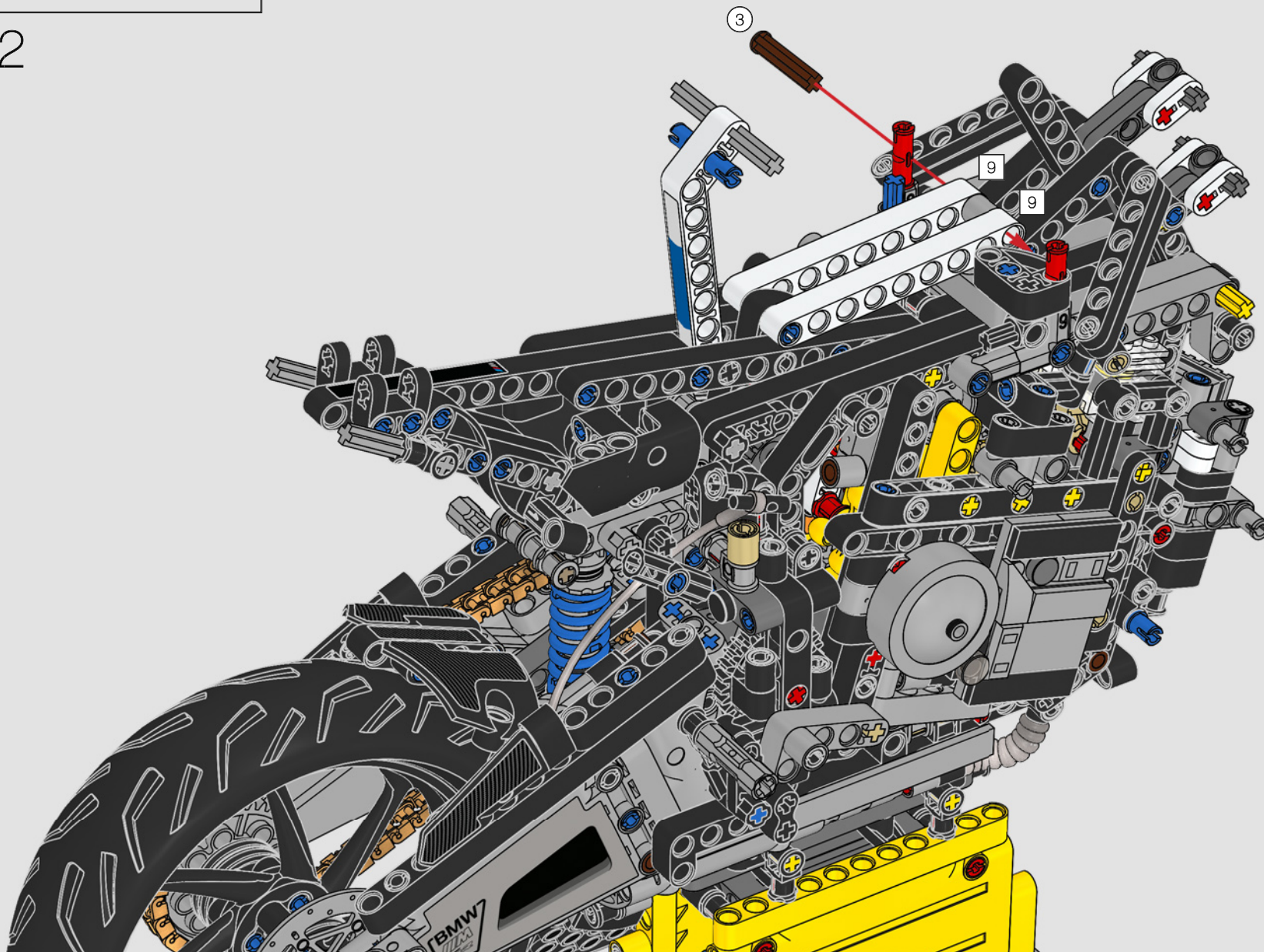

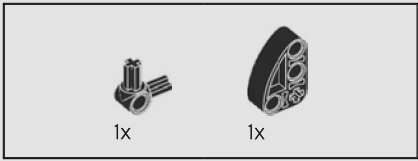

353

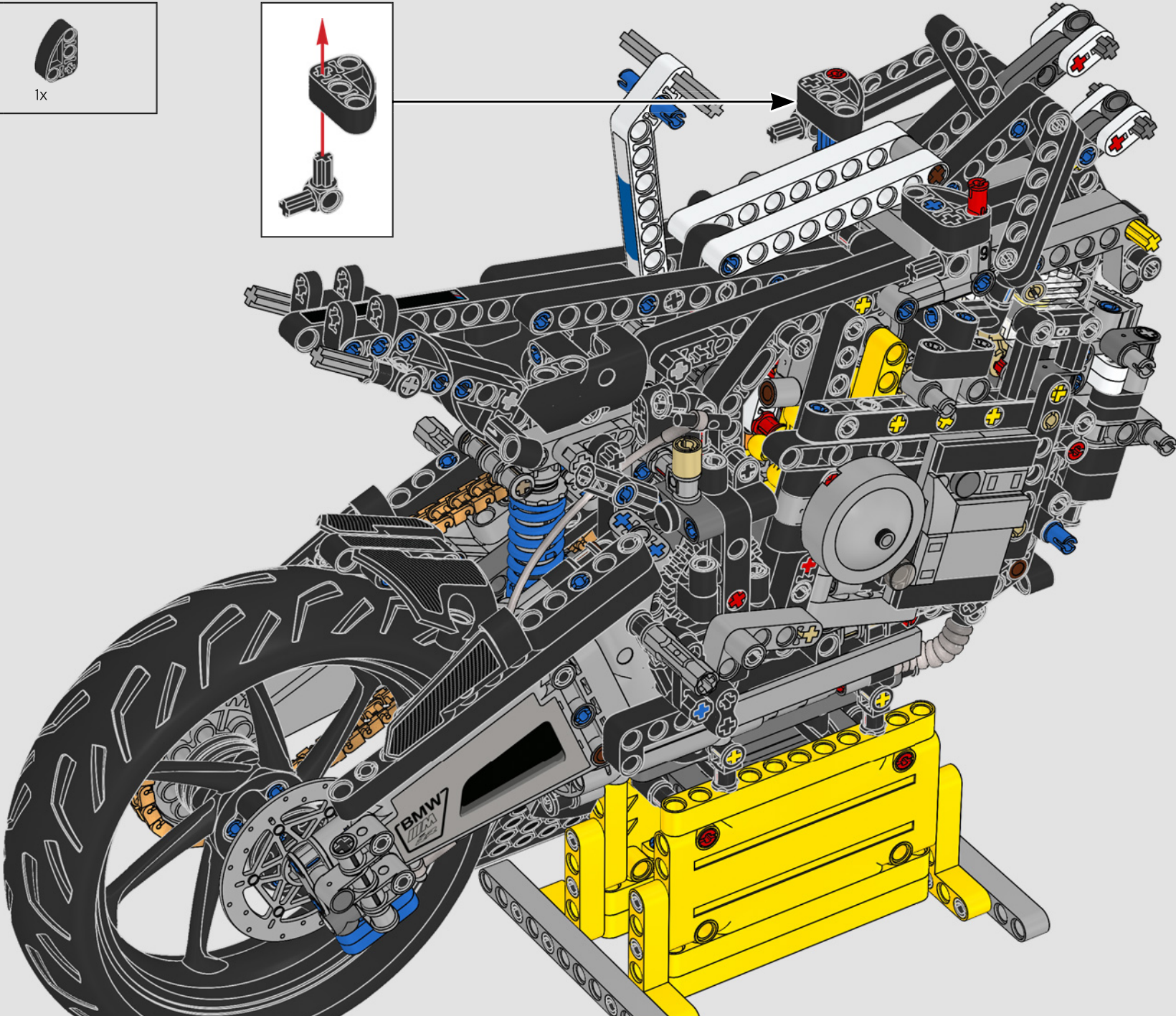
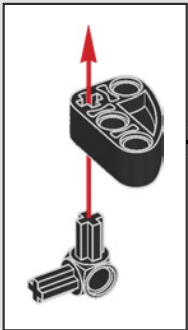

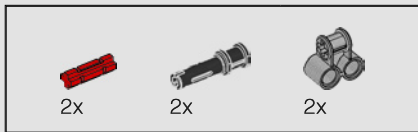

354

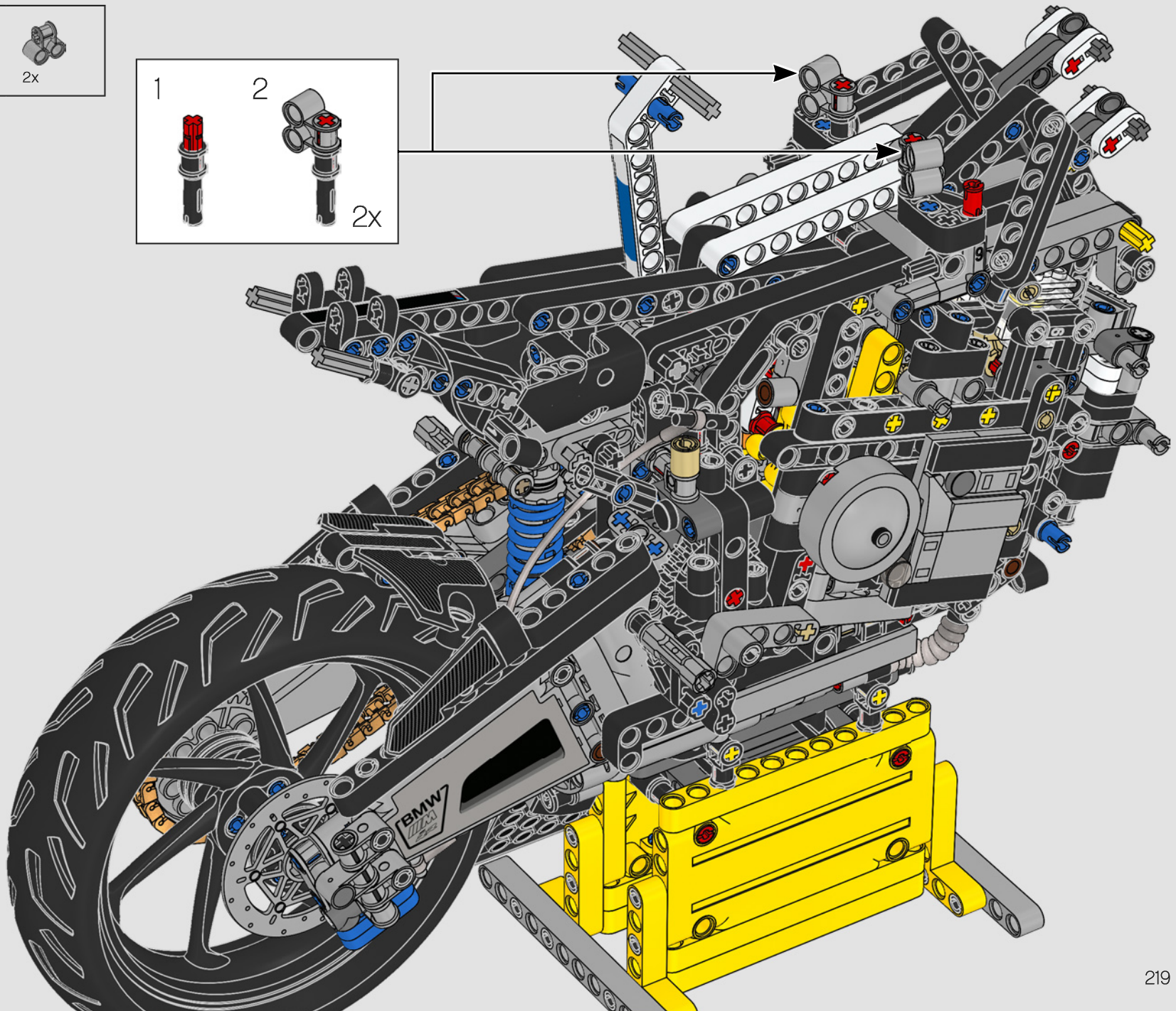
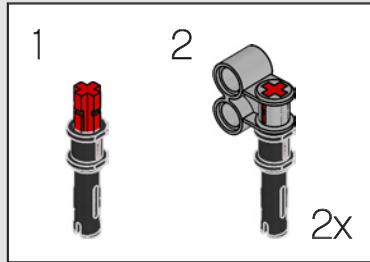

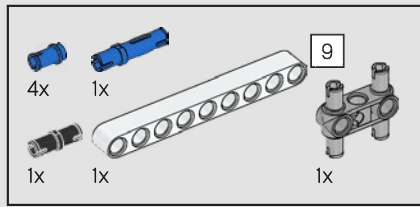

355

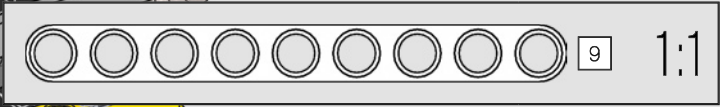
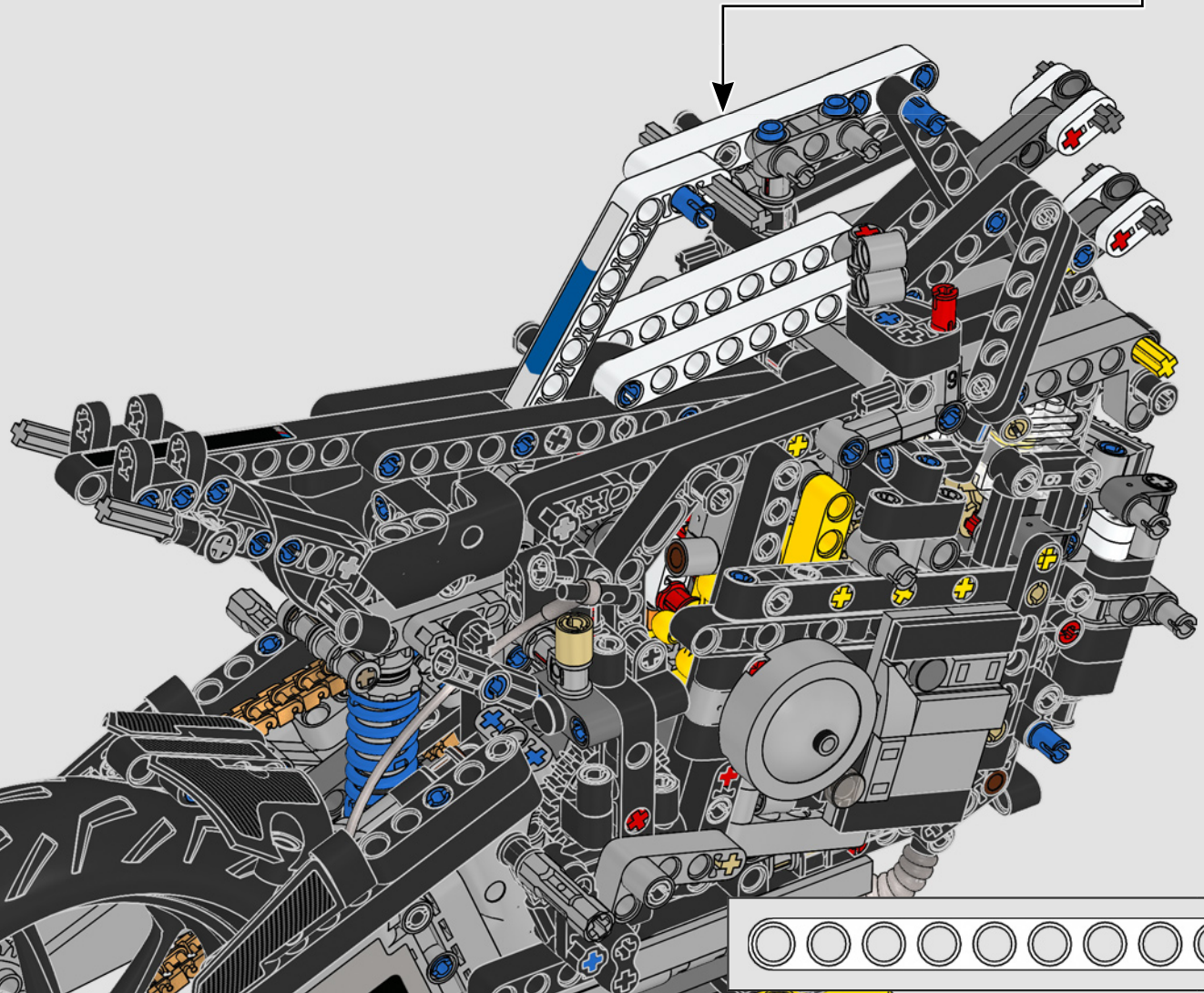
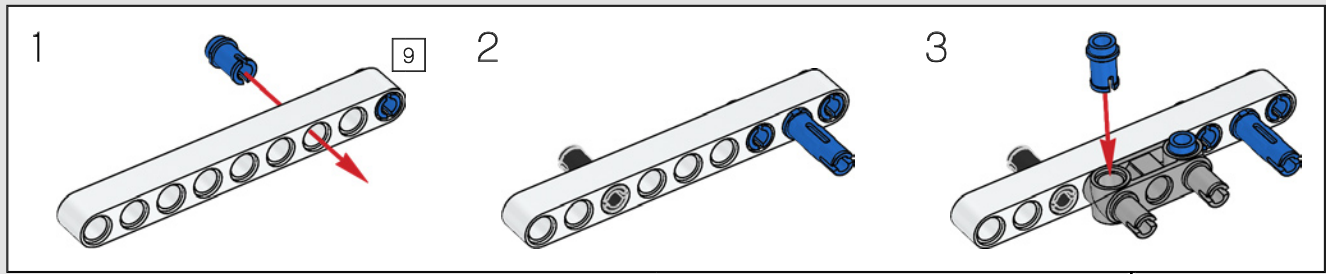

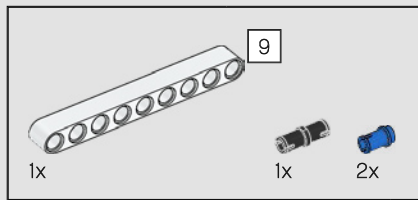

356

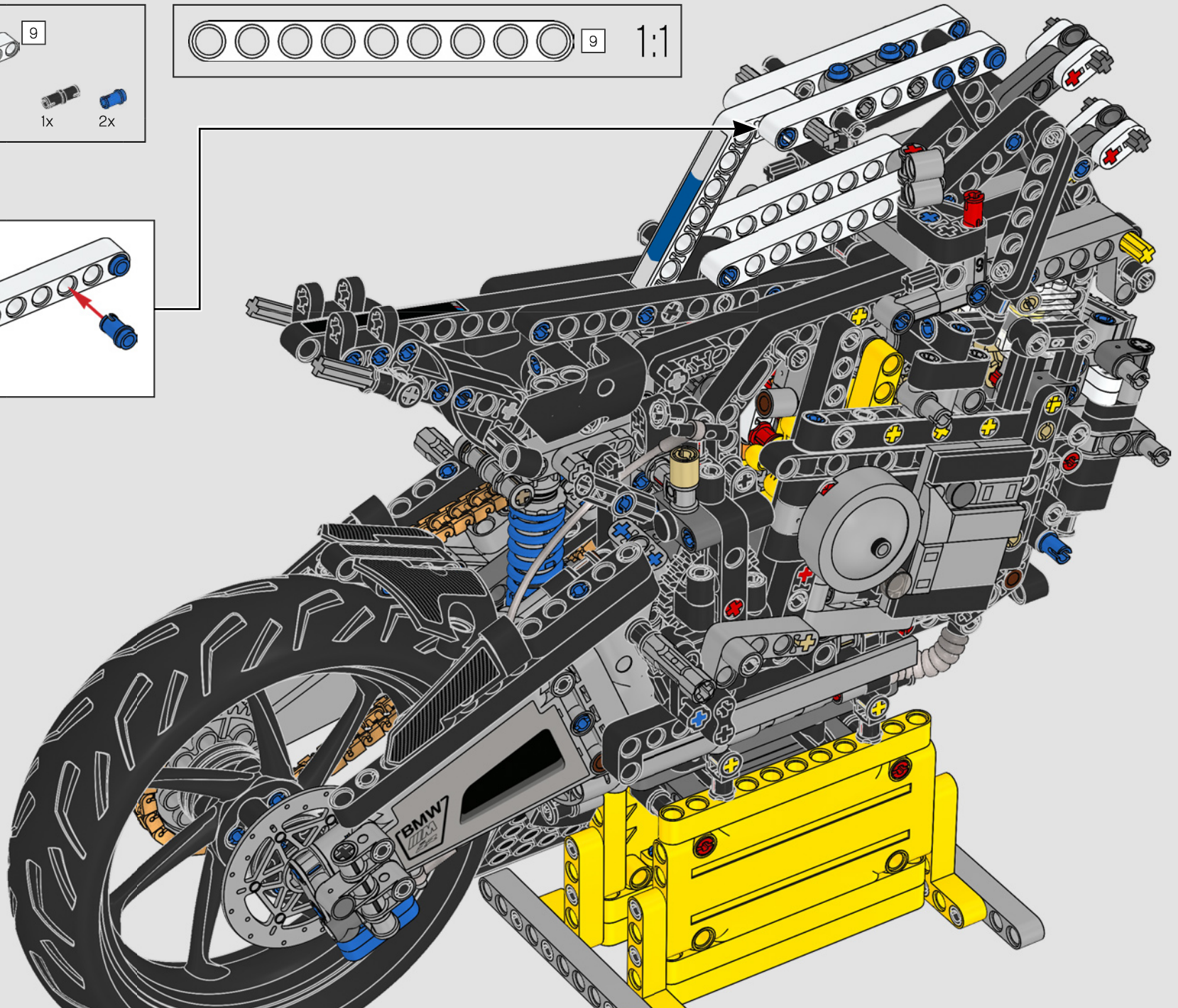
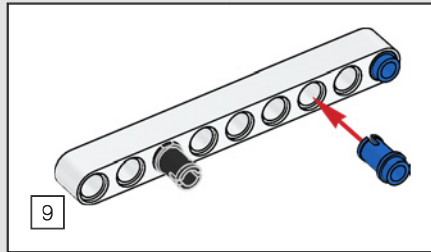

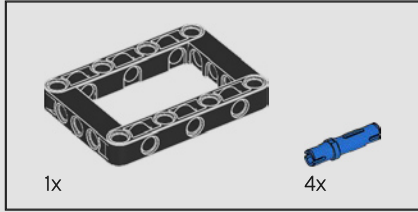
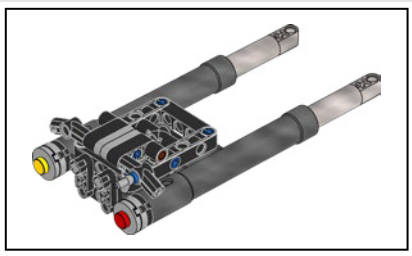

357

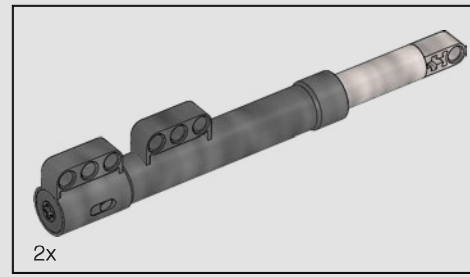
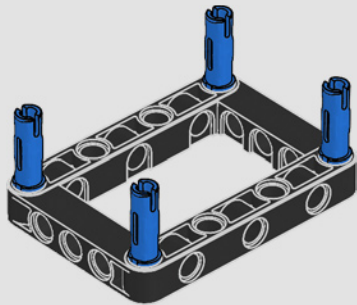

358

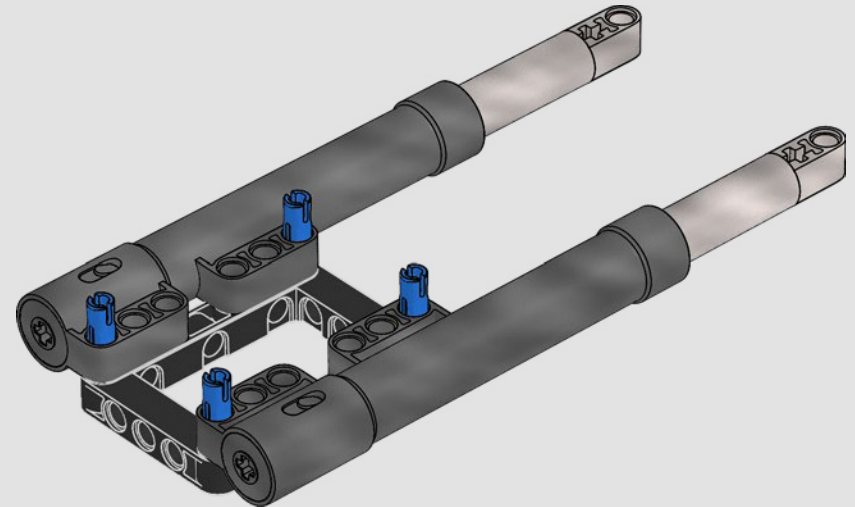

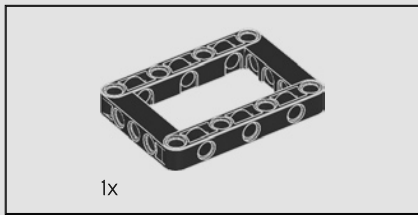

1x

359

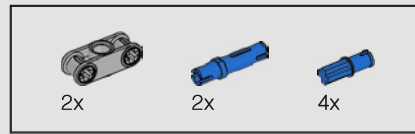
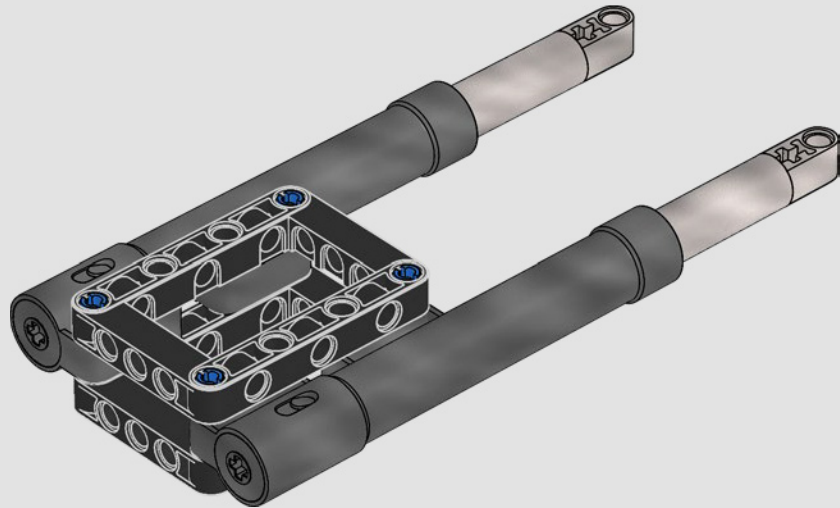

360

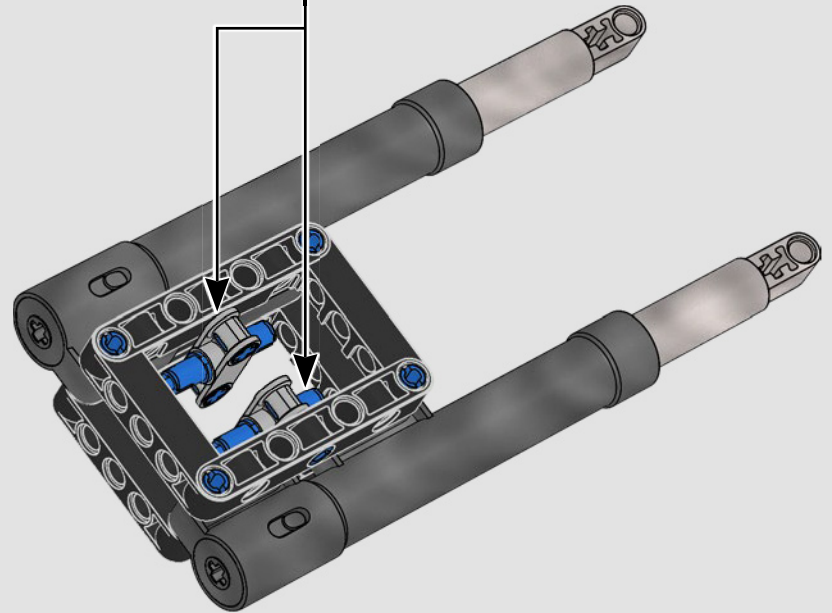
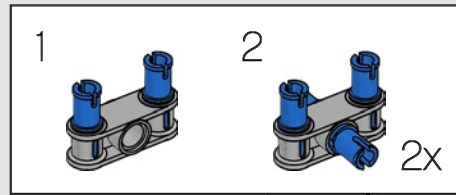
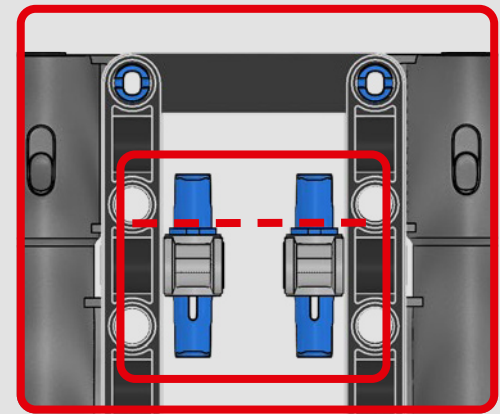

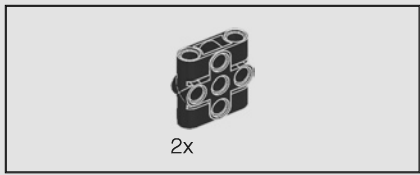

361

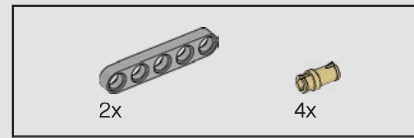
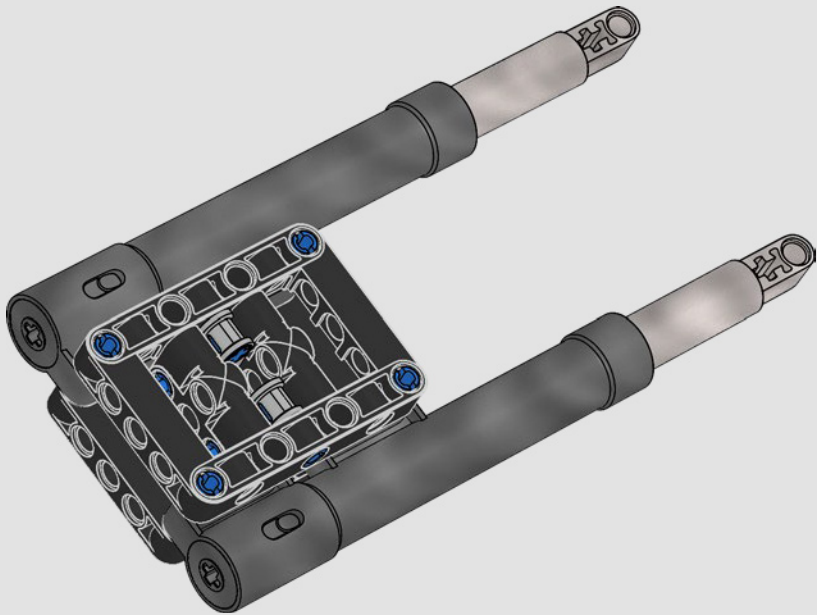

362

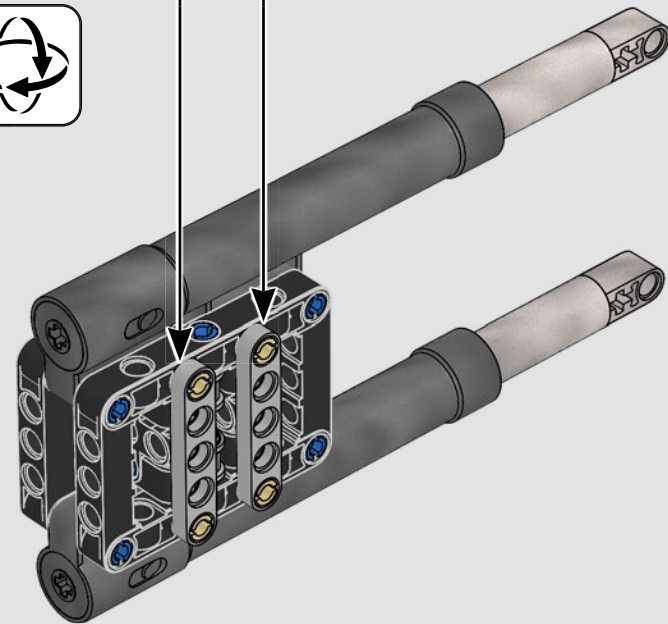
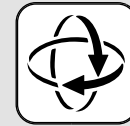
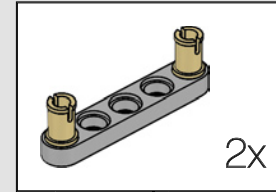

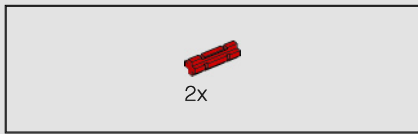

363

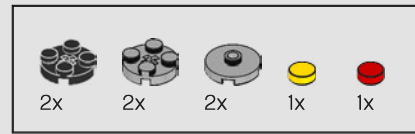
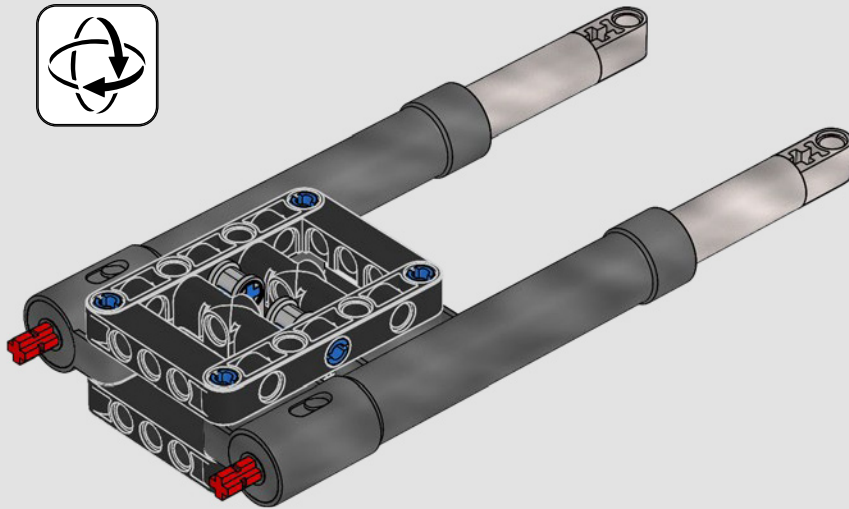

364

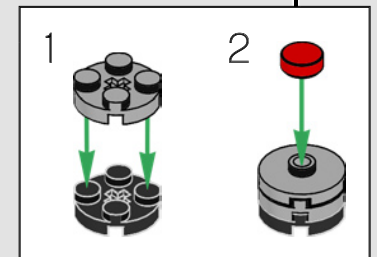
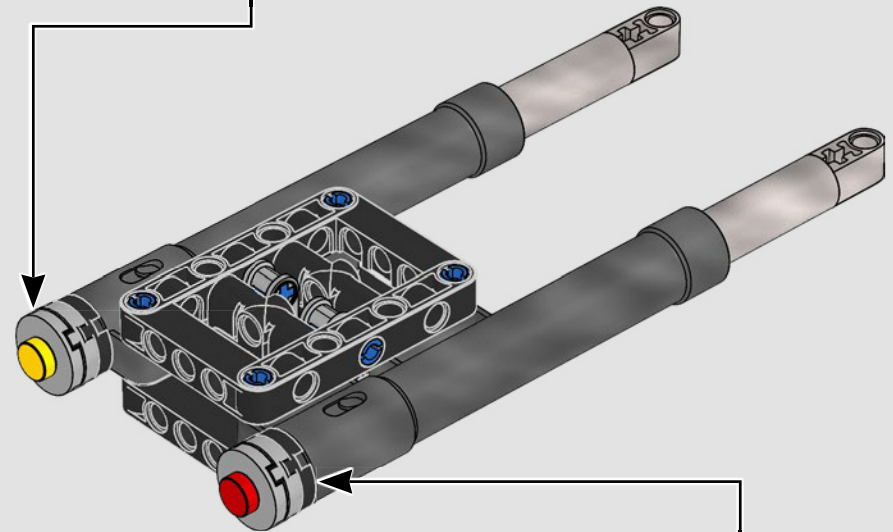
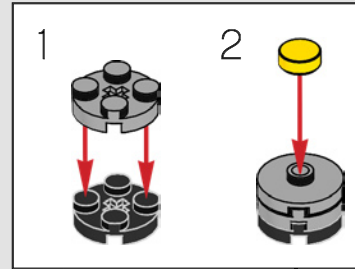



2x

365

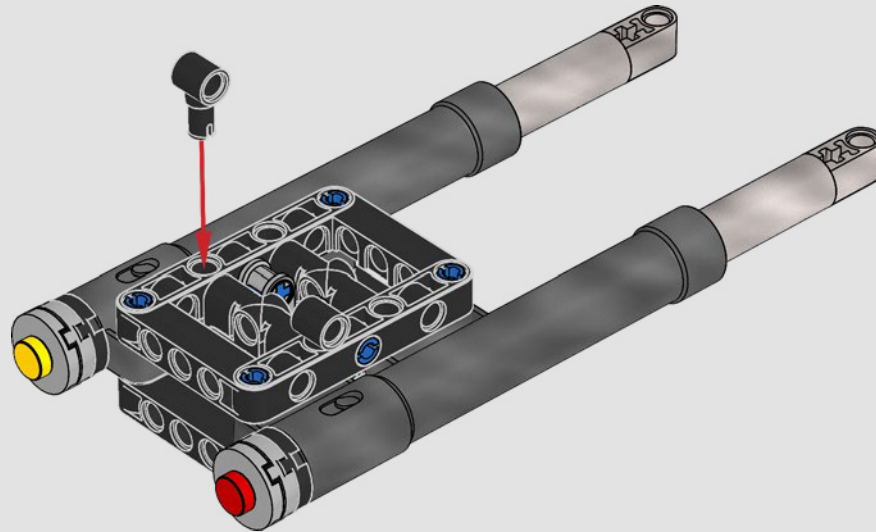

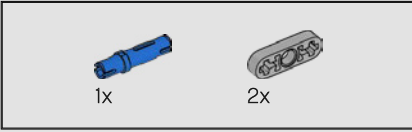
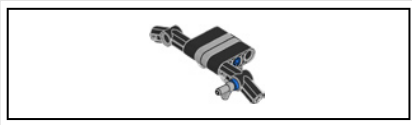

366

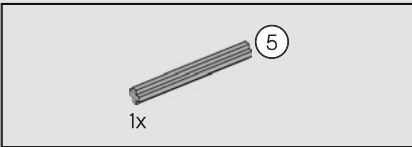
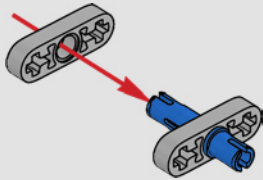

367

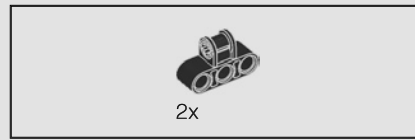
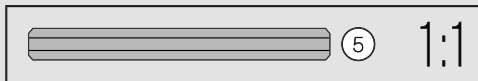
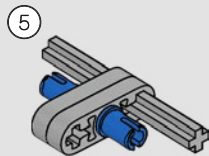

368

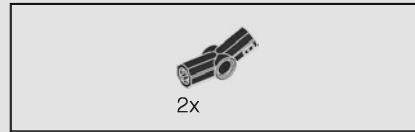
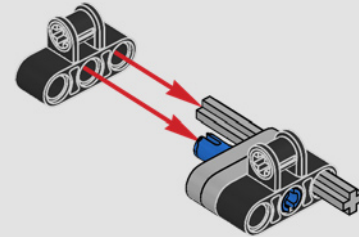

369

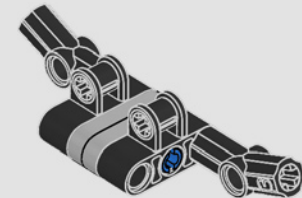
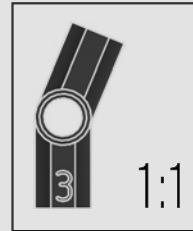

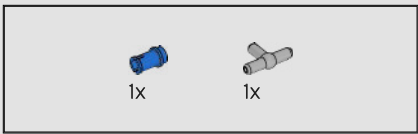

370

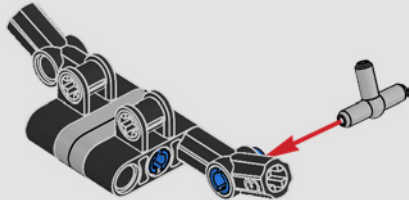

371

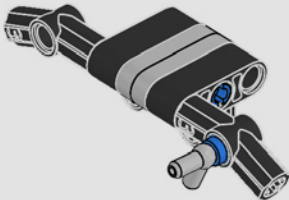

372

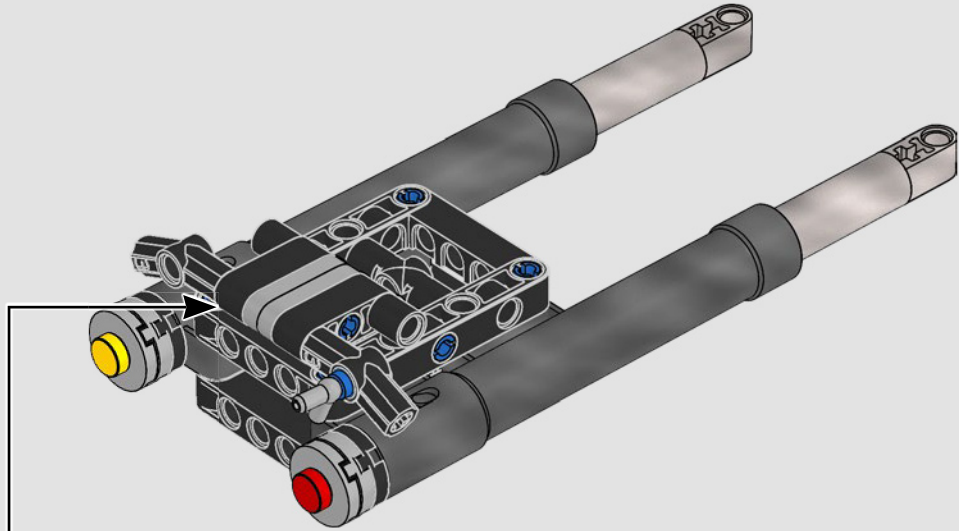

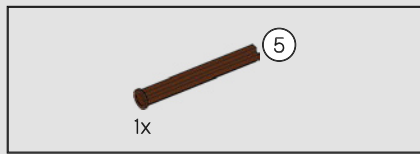

373

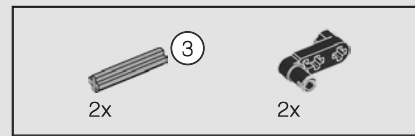
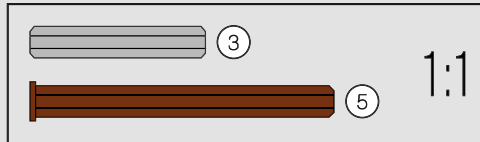
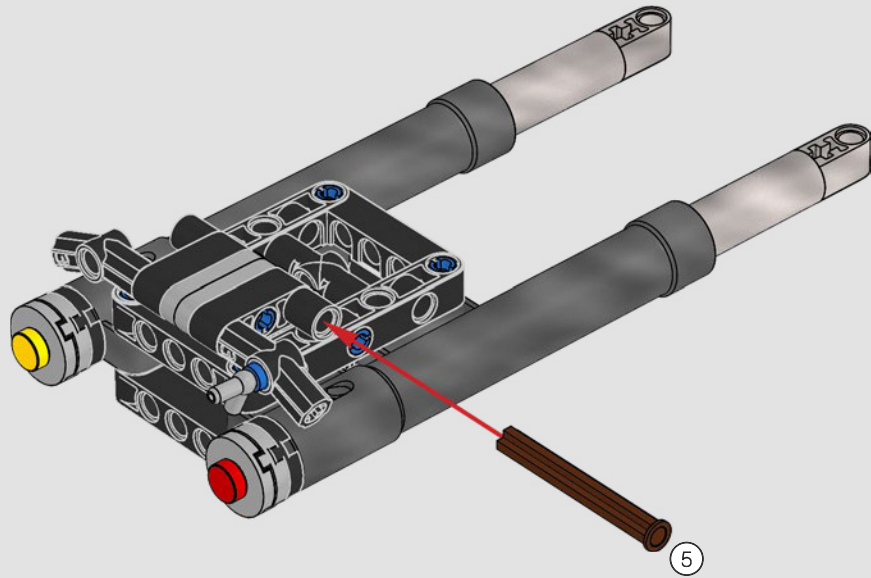

374

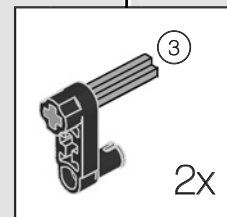
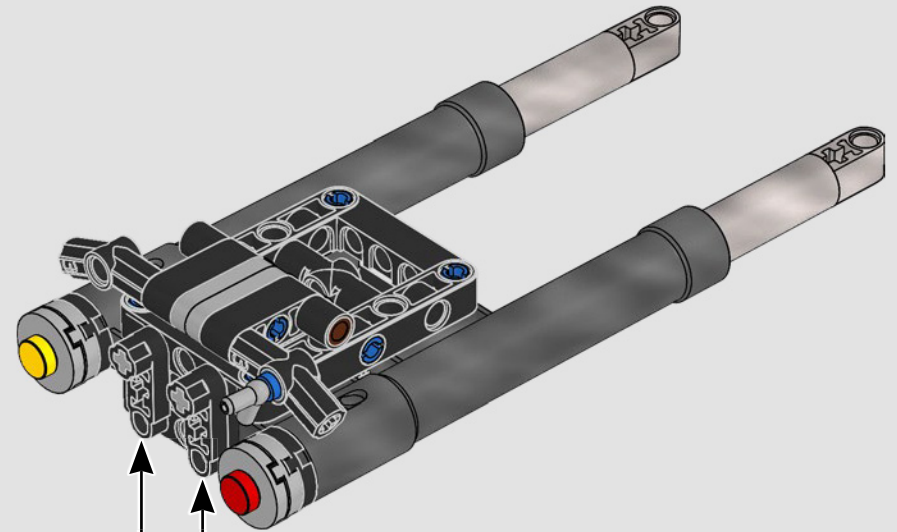

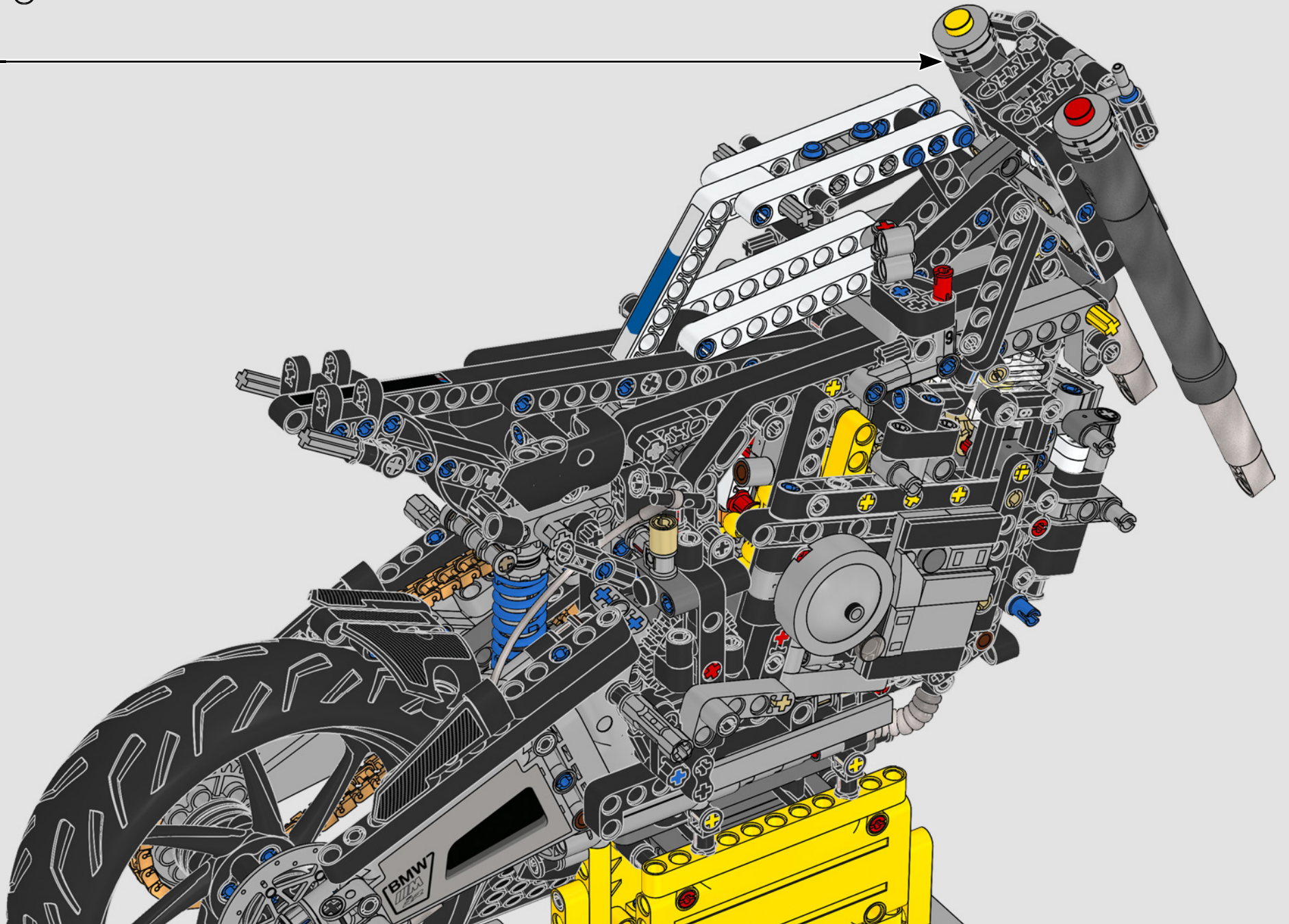

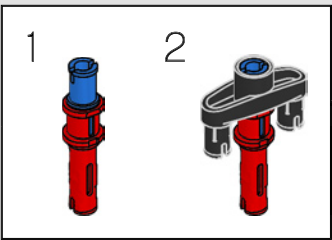
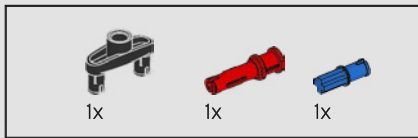

376

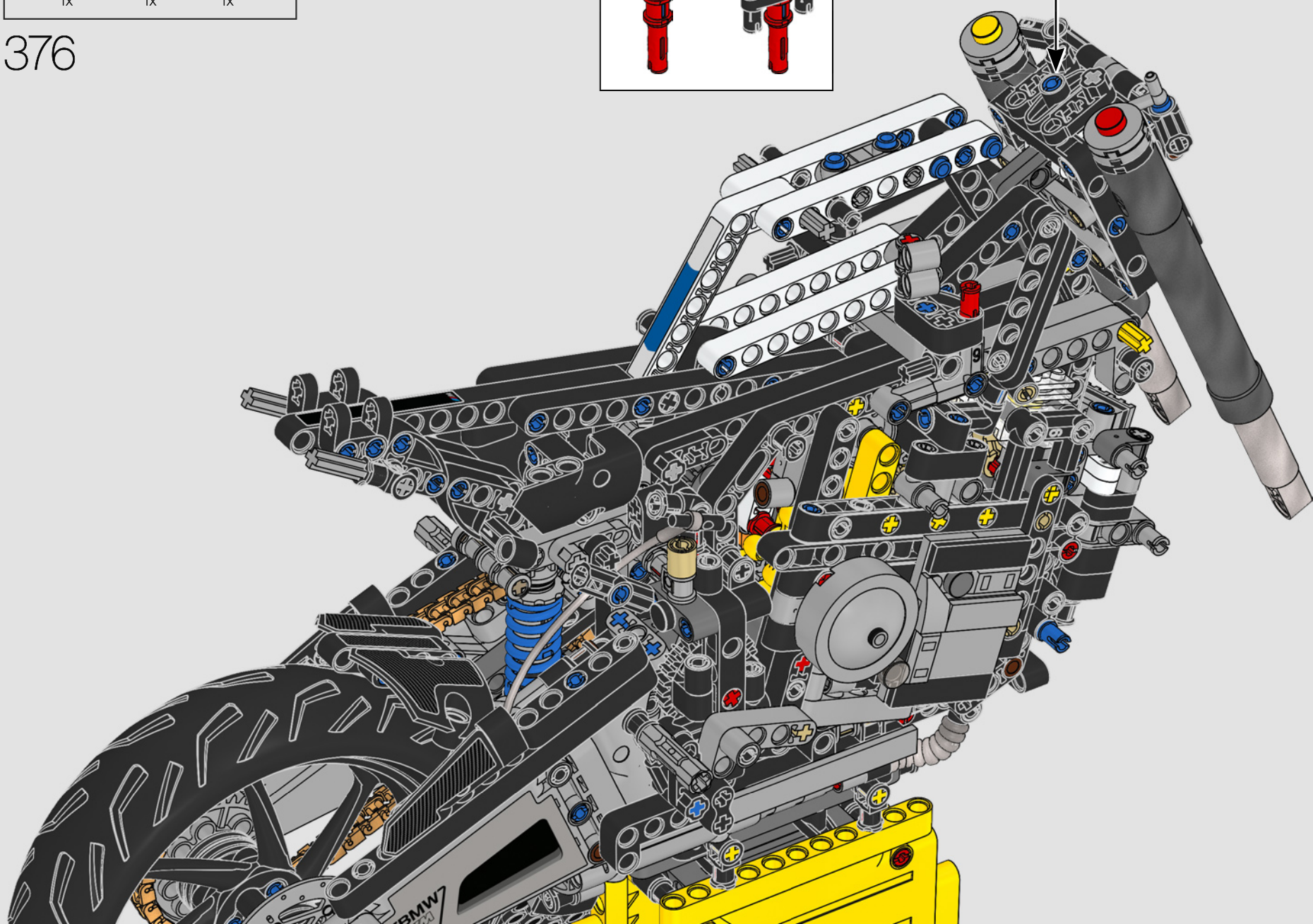

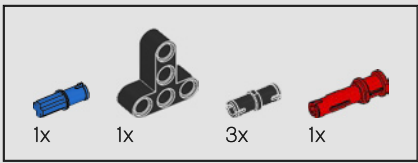

377

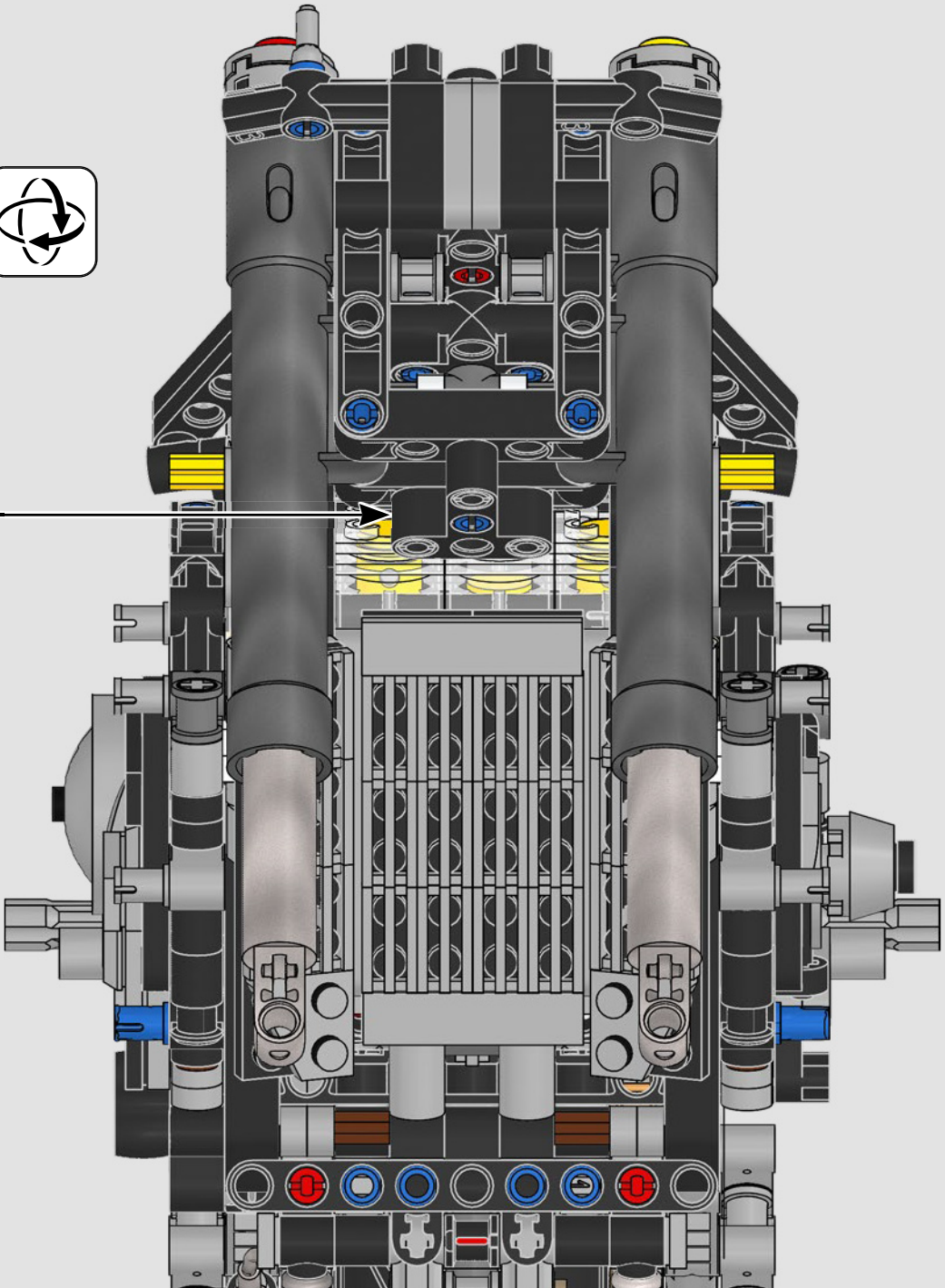
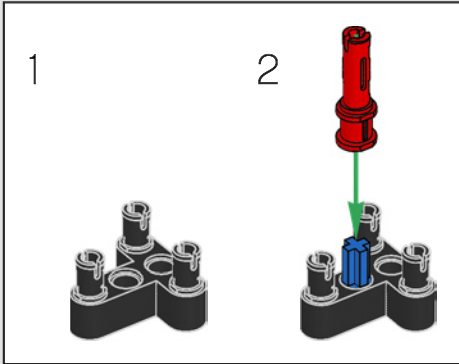

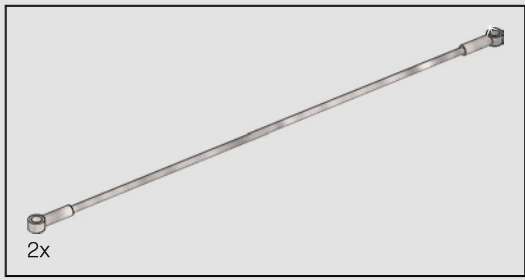

378

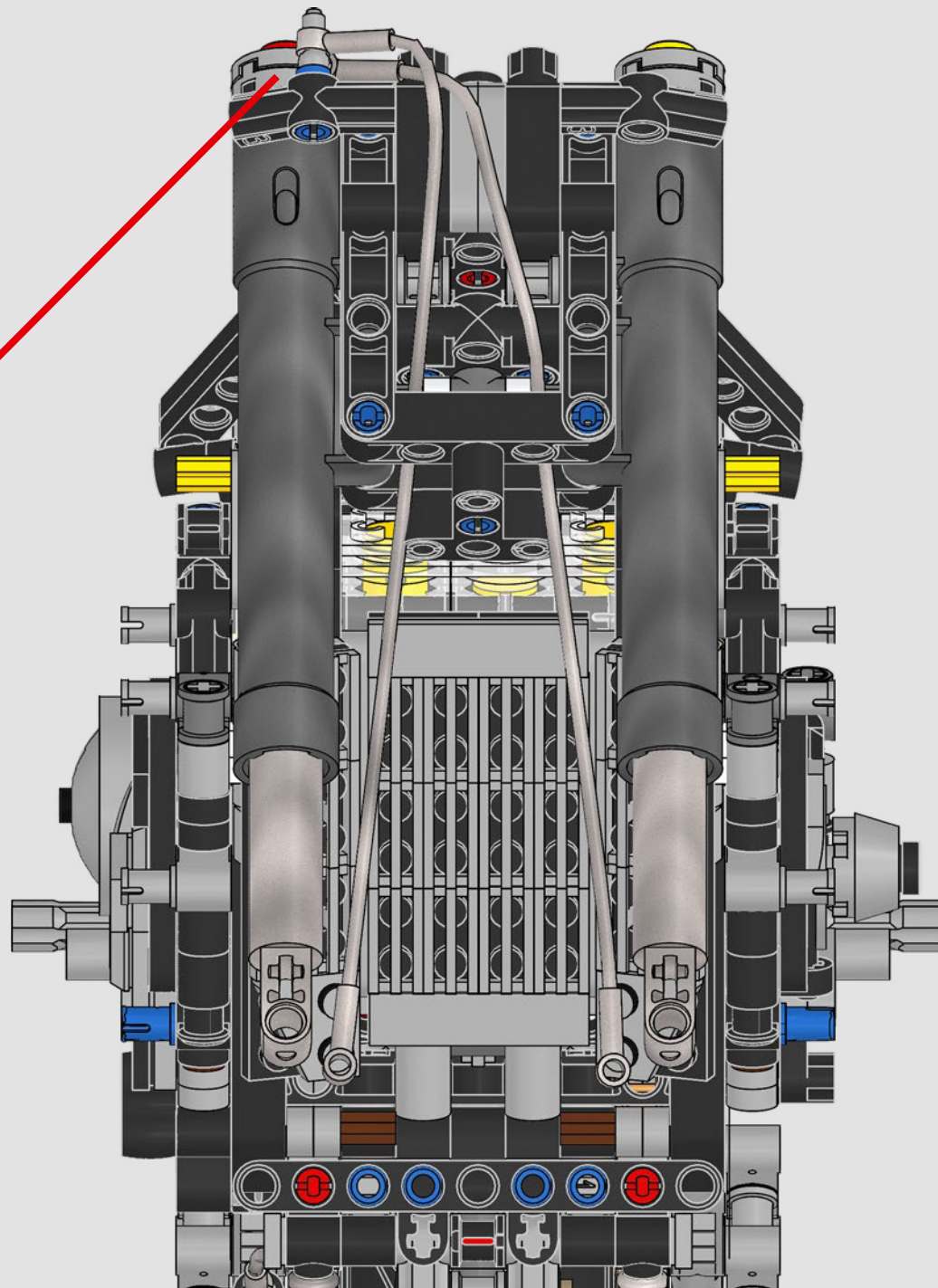
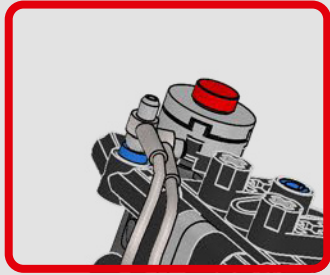

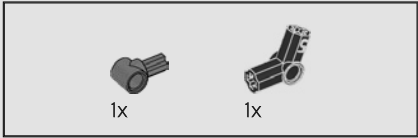
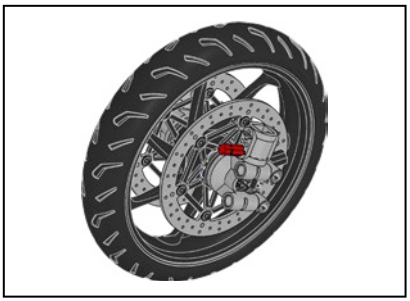

379

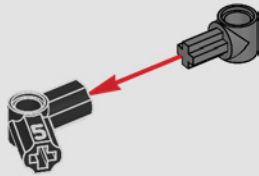

380



381

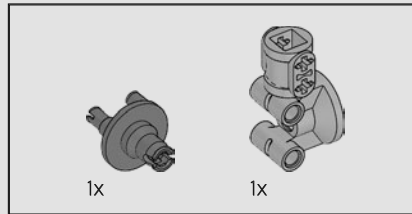
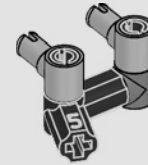

382

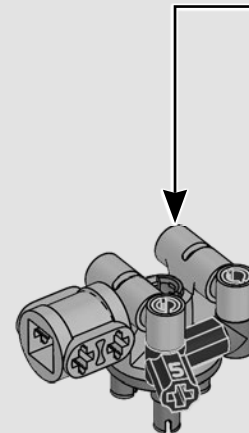
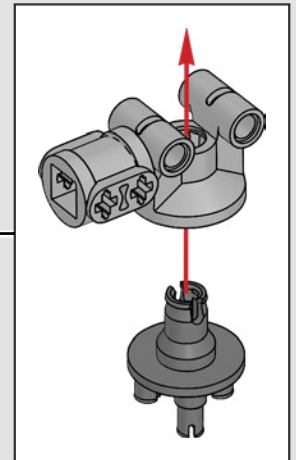

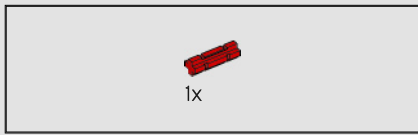

383

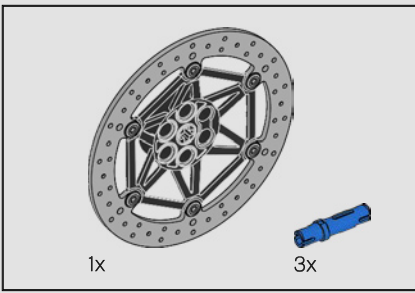
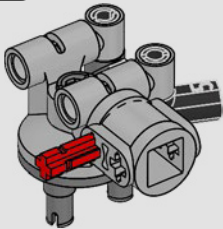

384

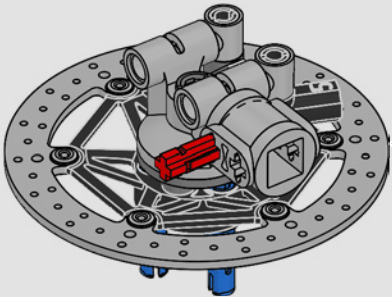
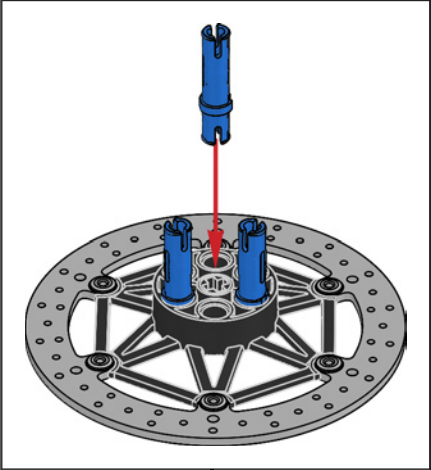

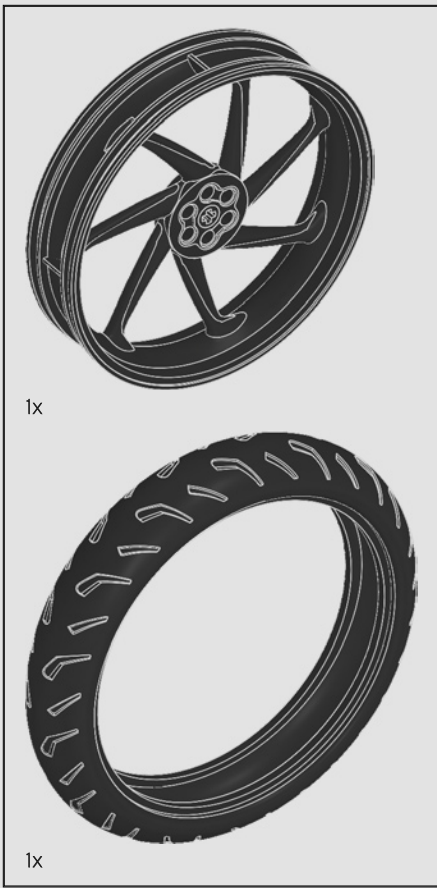

1x

1x

385

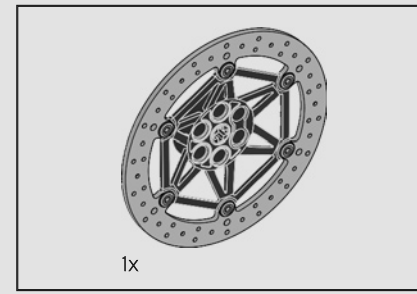
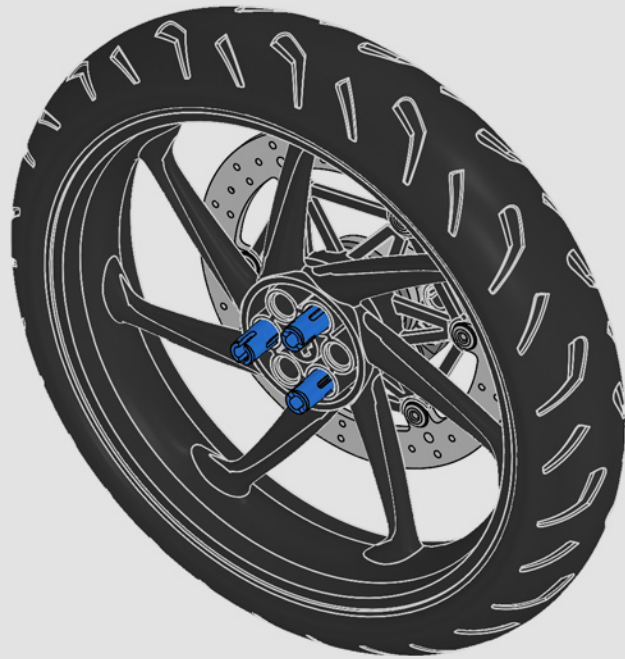

1x

386



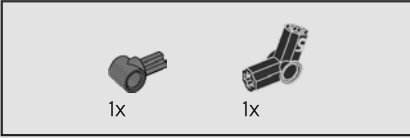
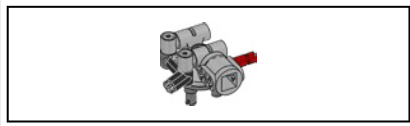

387

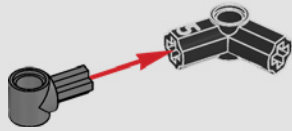

388

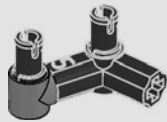

389

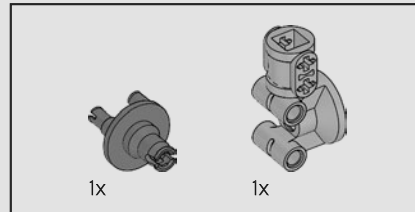
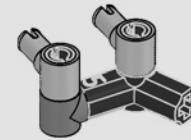

390

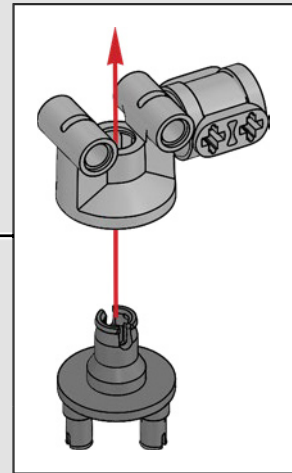
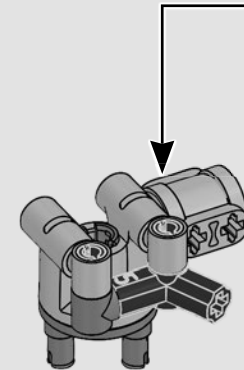



1x

391

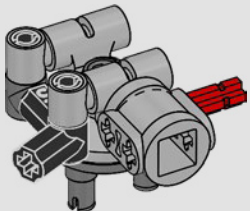

392



393

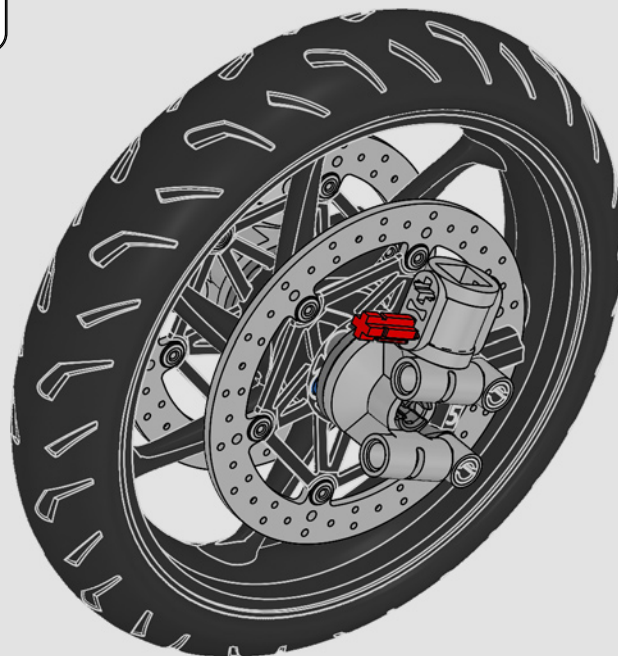

394

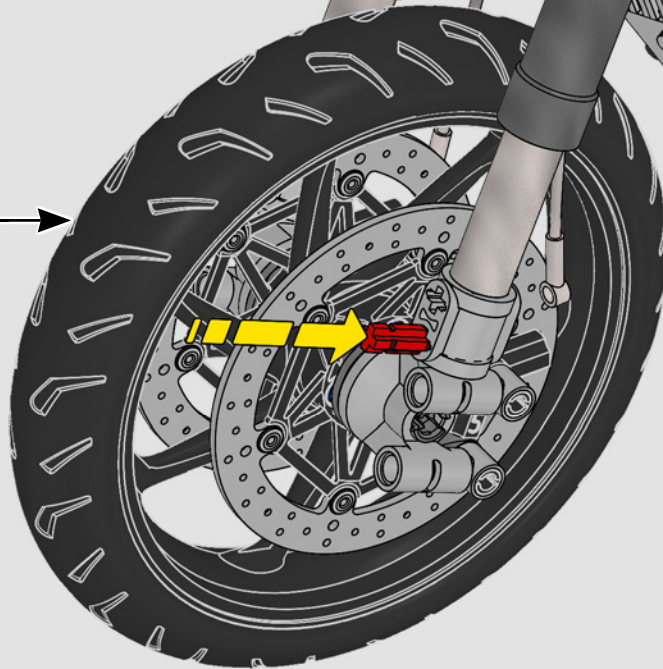
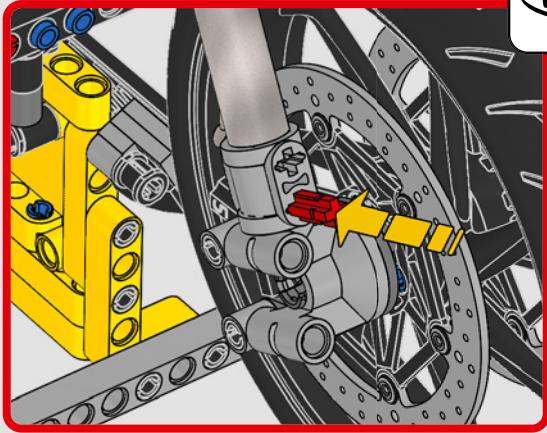

BMW MOTORRAD

Power:	212 HP
Nmax:	15,100 rpm
Torque:	113 Nm
CC	999
Ymax.	306 km/h
Acceleration	325 km/h (<3.1 sec.)
Weight Din	0-100 km/h <7.5 sec.
Downforce	0-200 km/h <7.5 sec.
	192 kg
	Winglet 16,3 kg

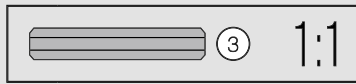
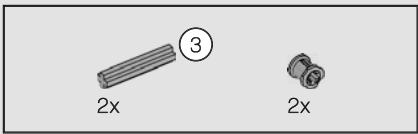

395

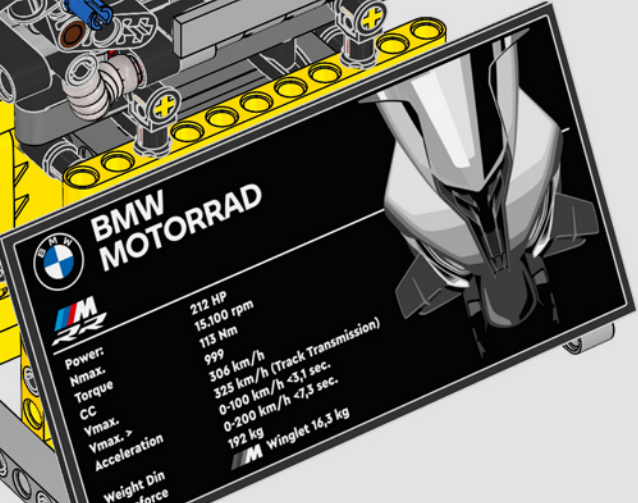
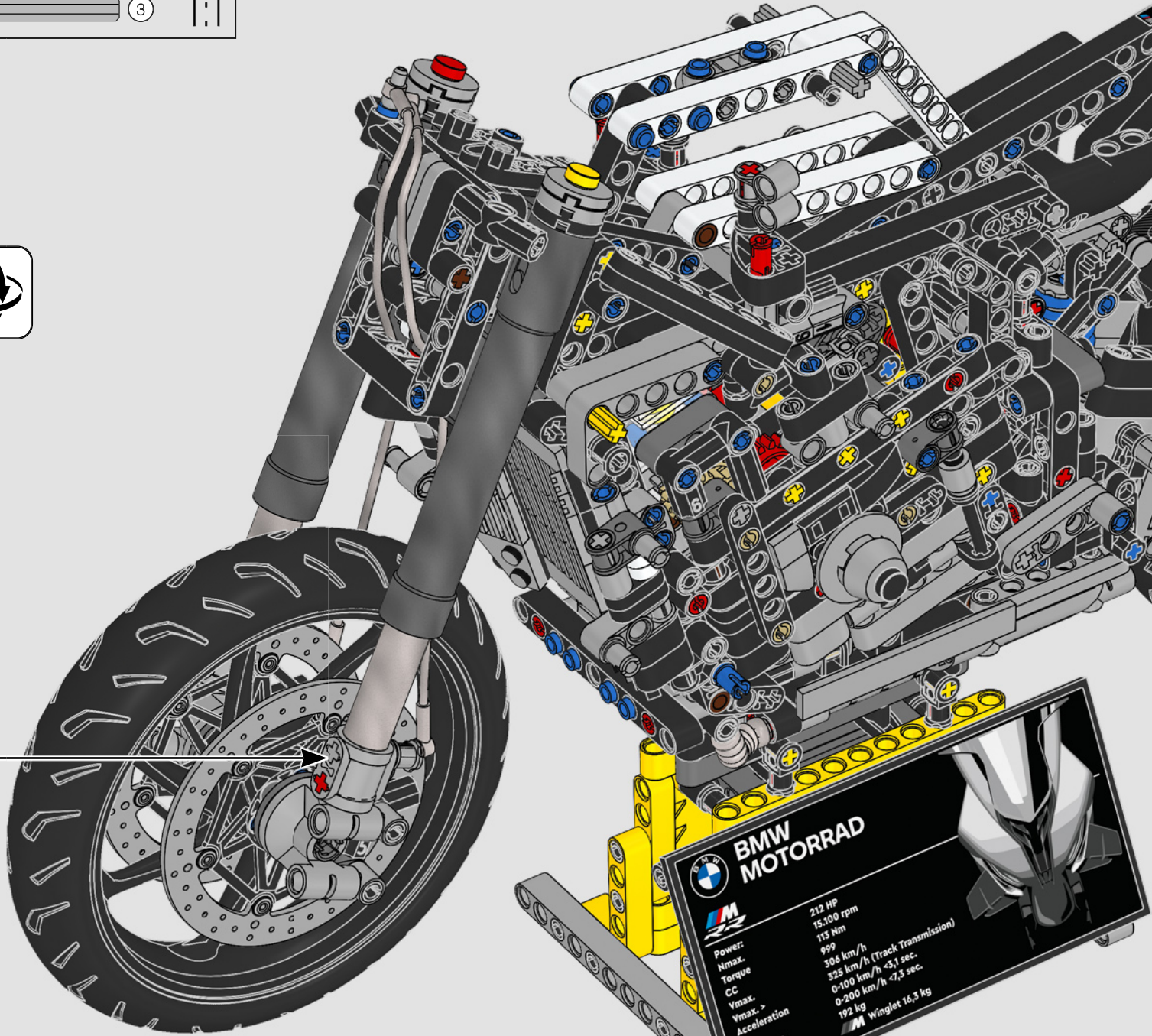
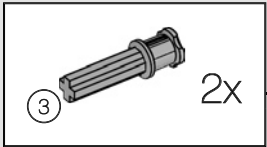
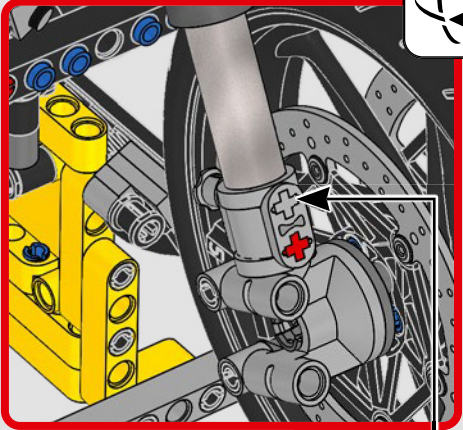



396



397

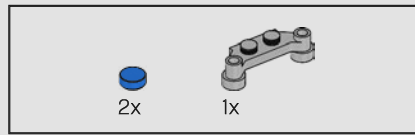

398

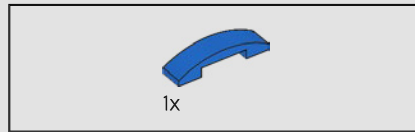
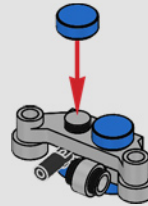

399

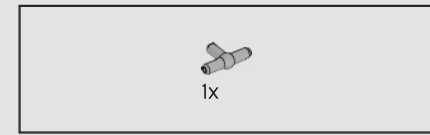
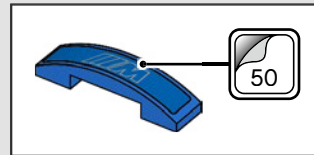

400

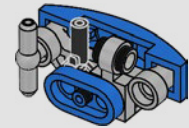
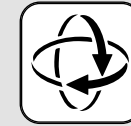

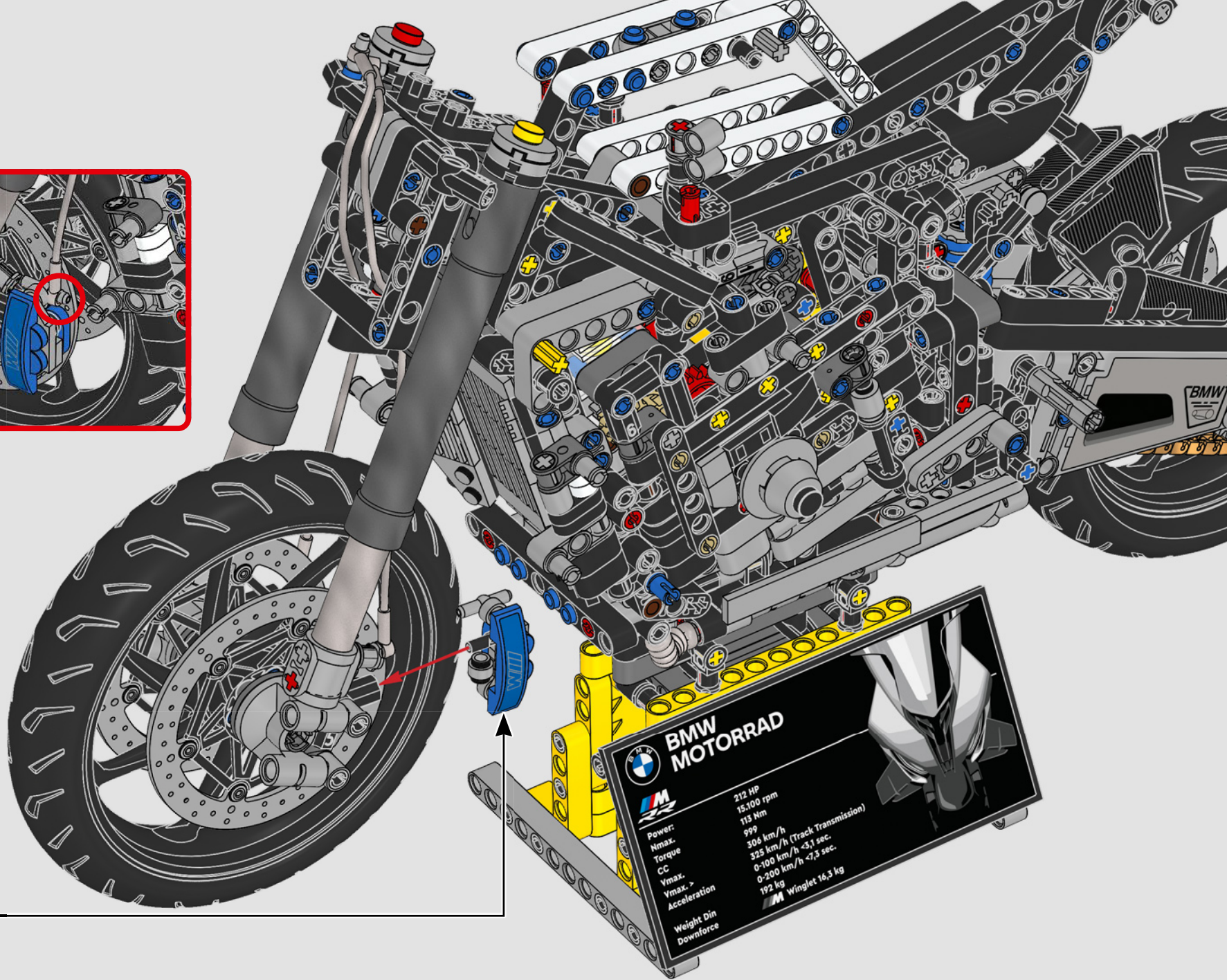
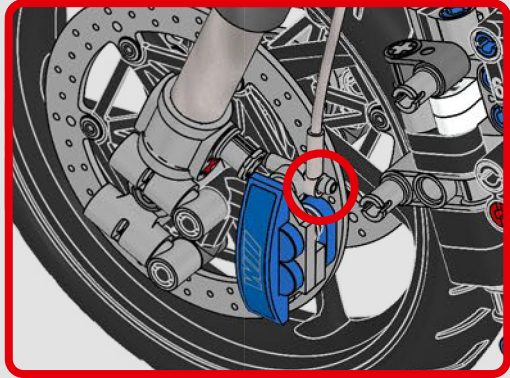



402



403

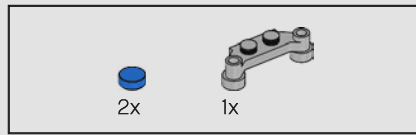

404

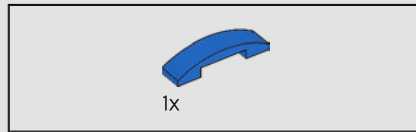
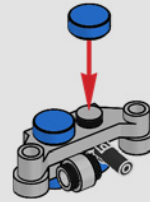

405

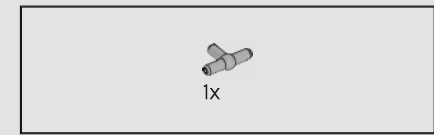
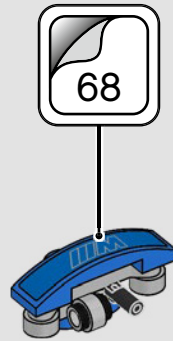

406

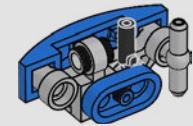
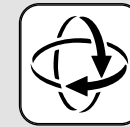

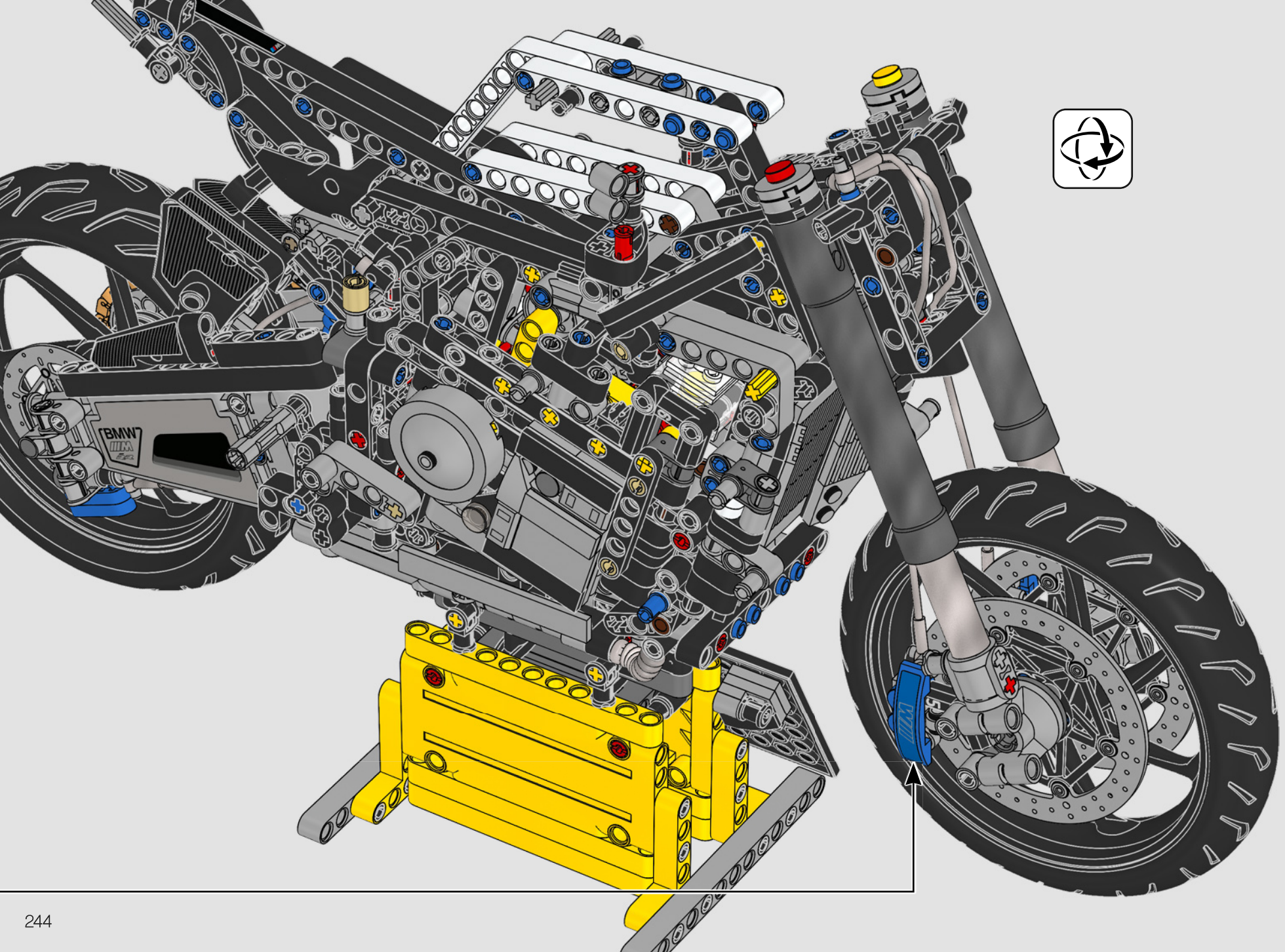

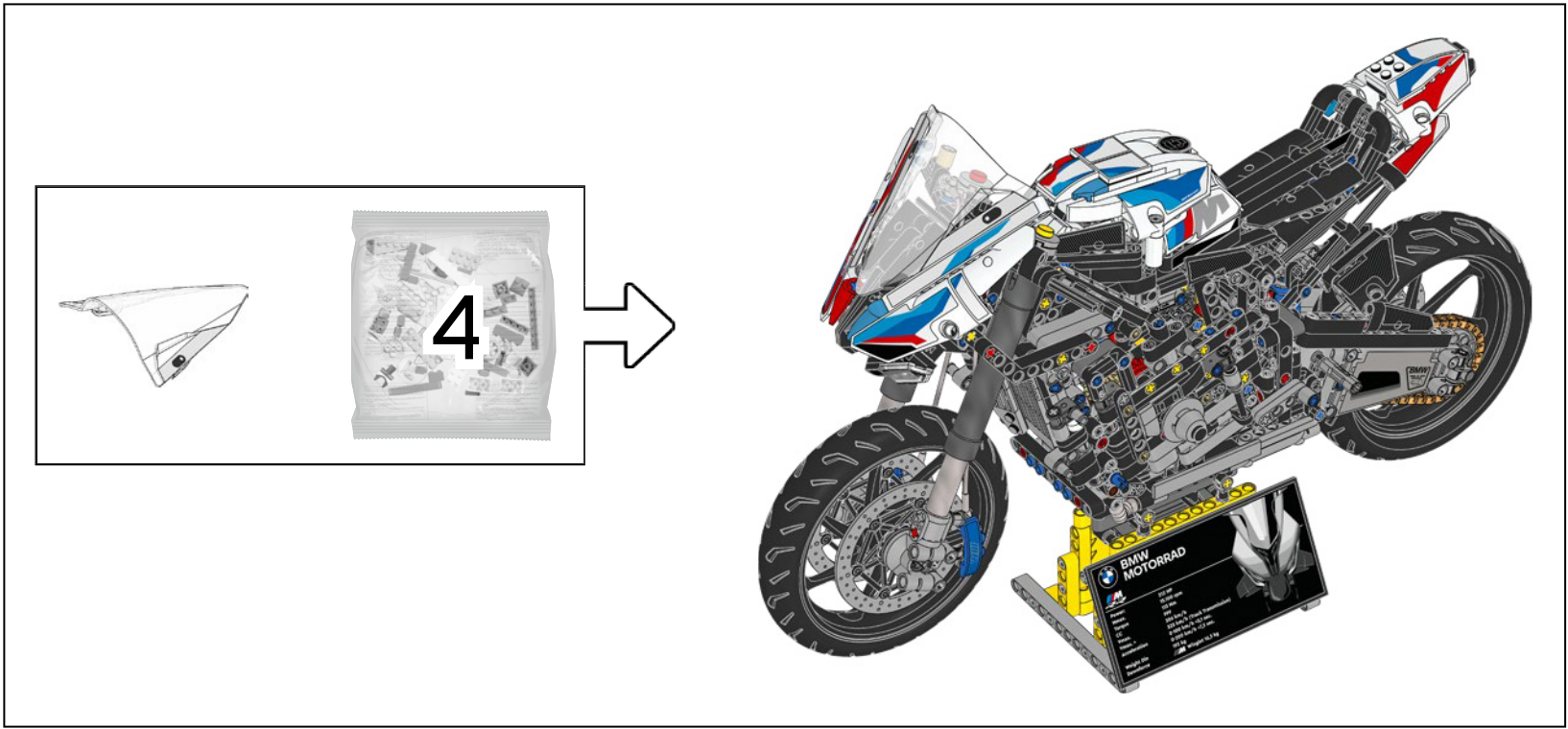

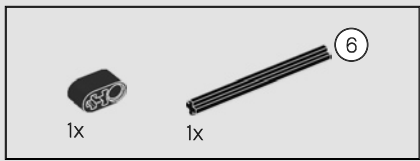

407

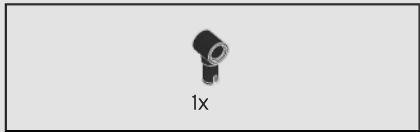
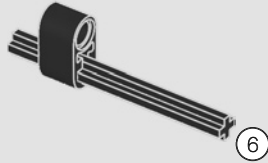

408

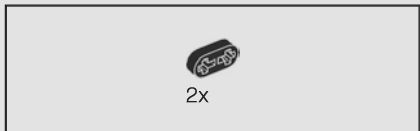
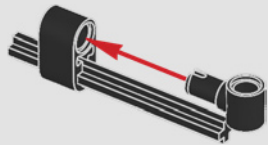

409

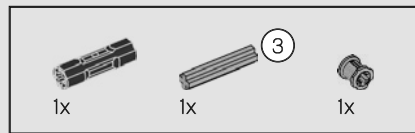
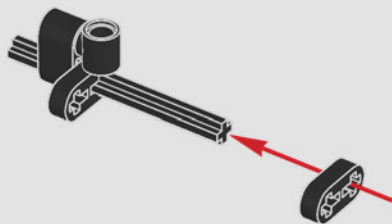

410

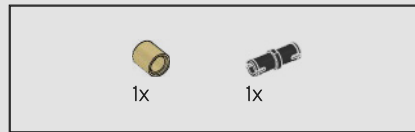
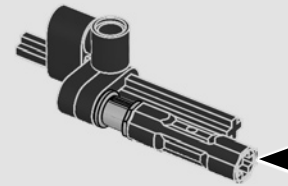
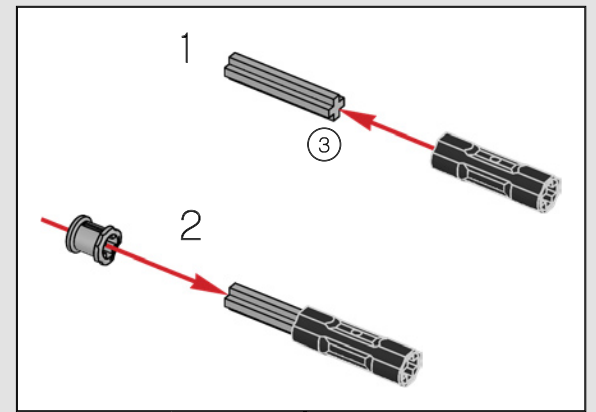

411

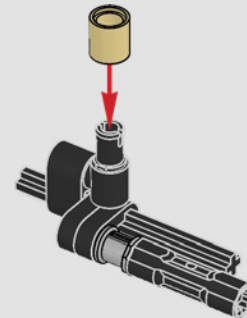

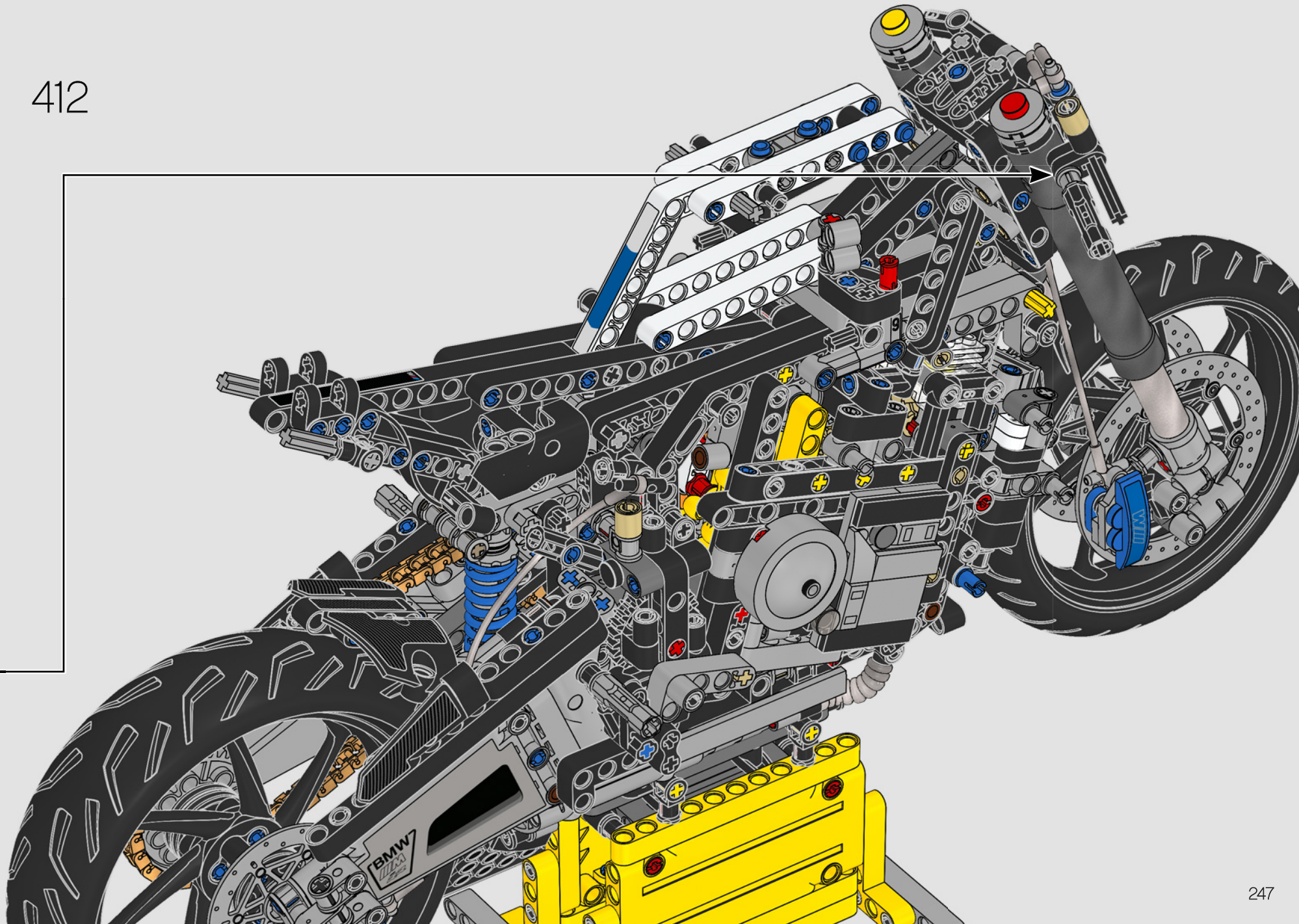

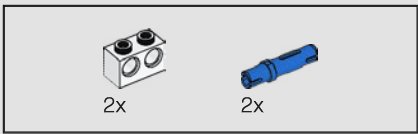

413

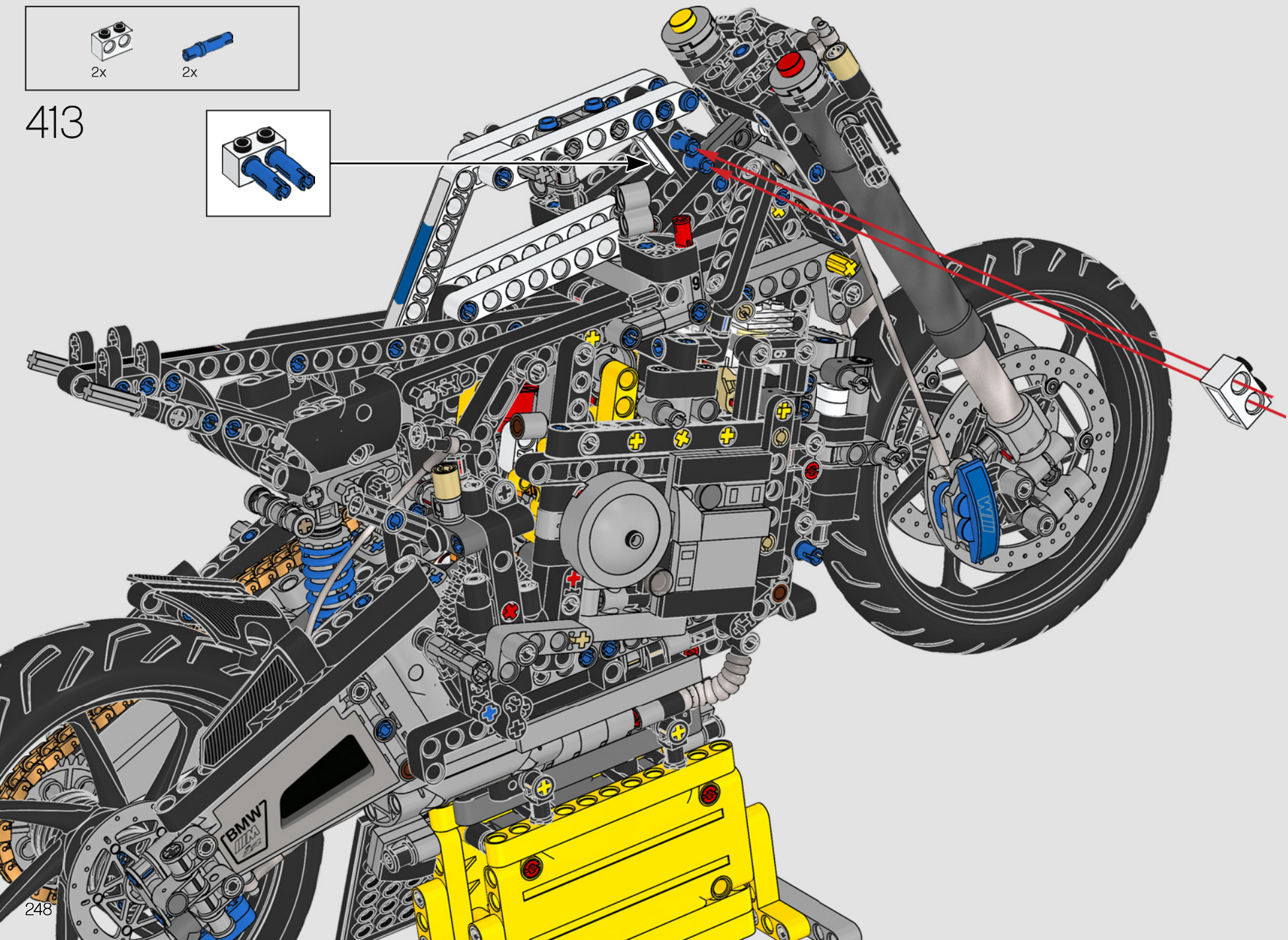
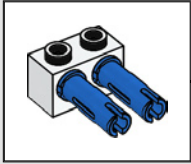

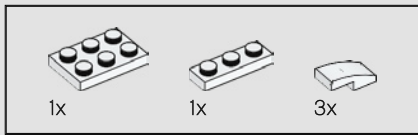

414

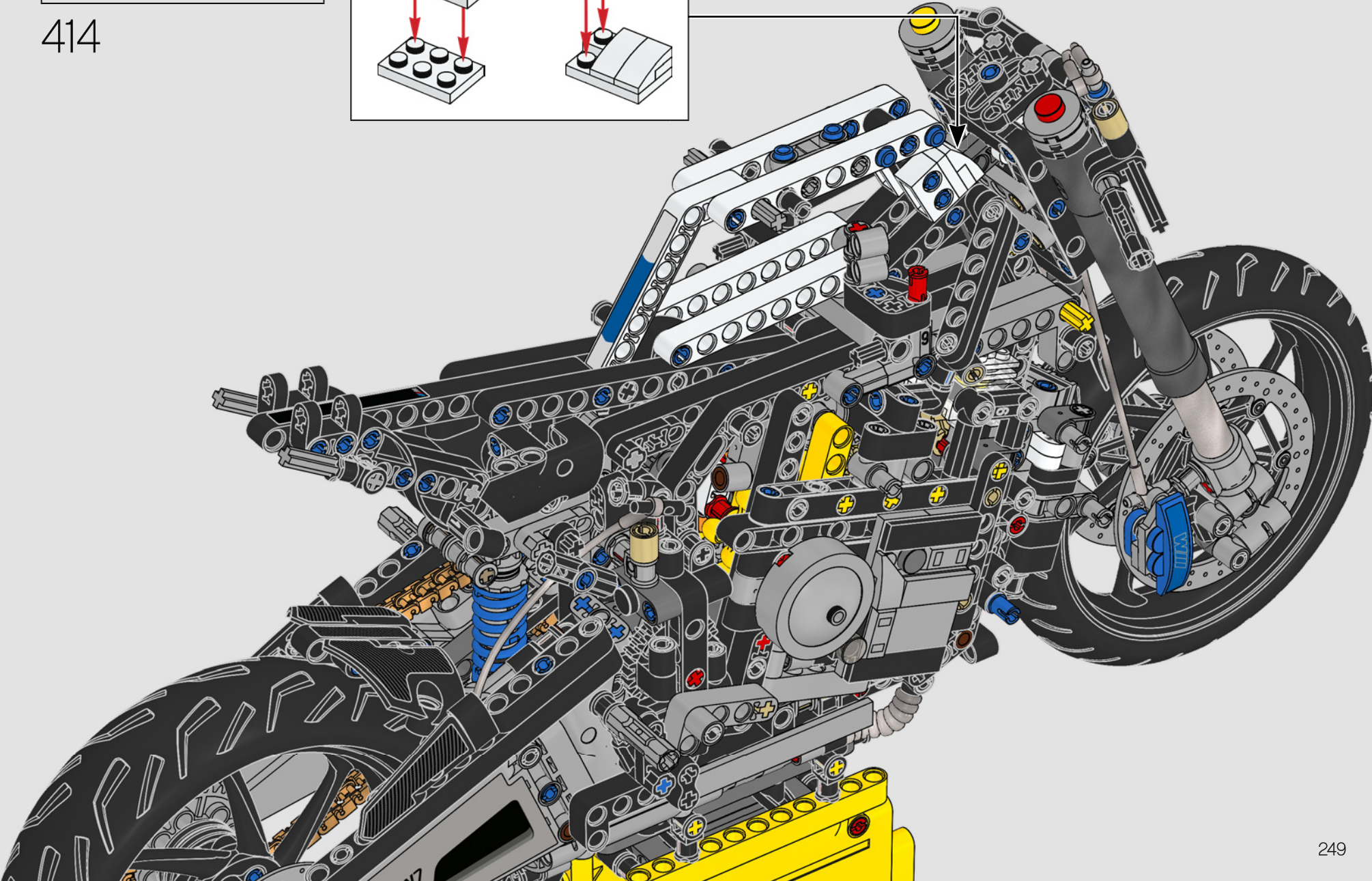
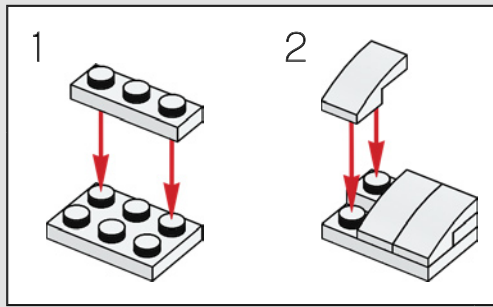

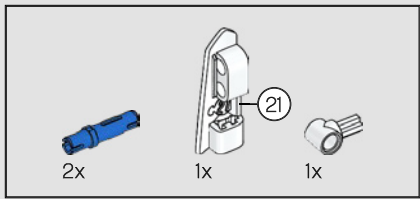

415

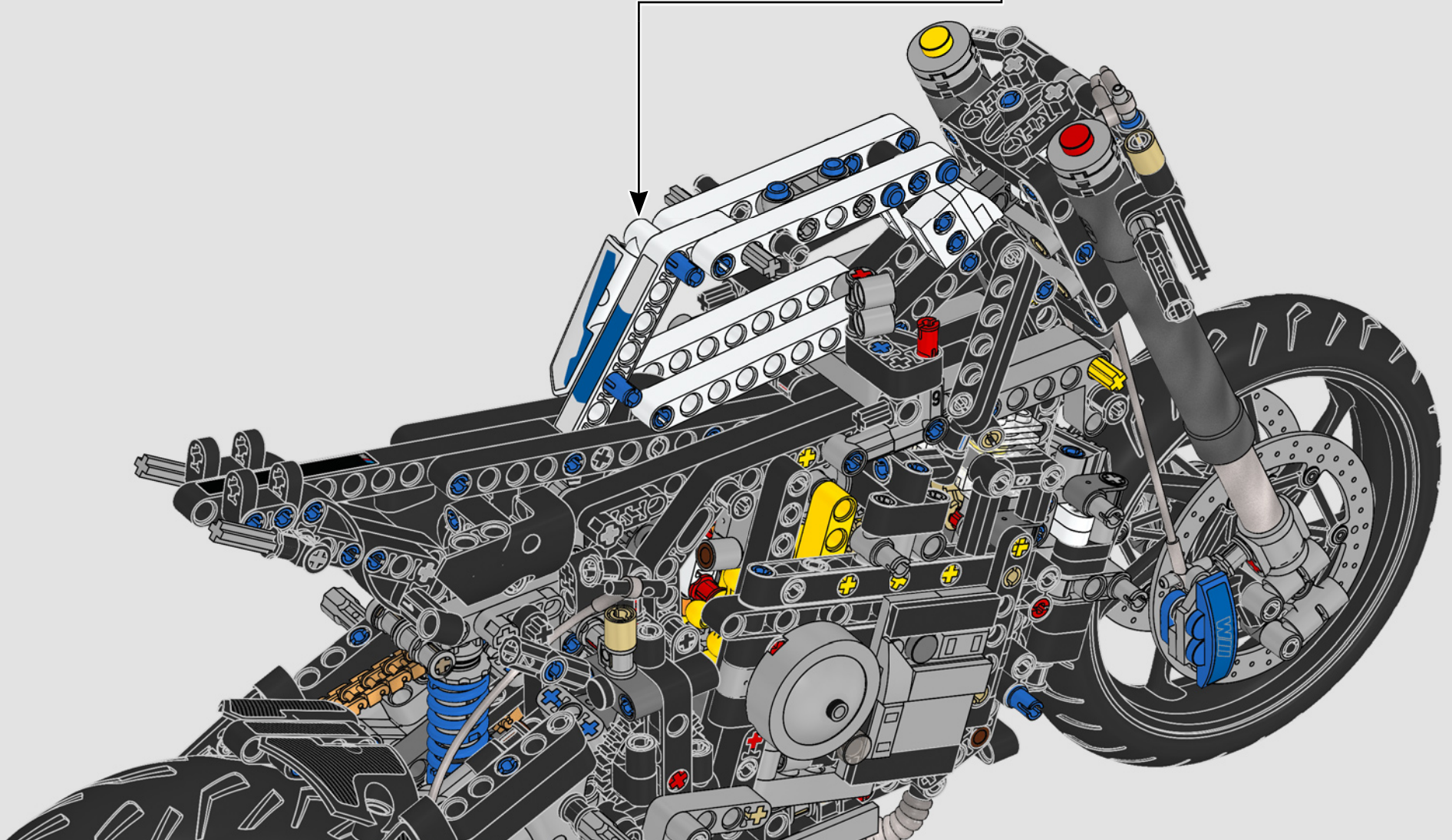
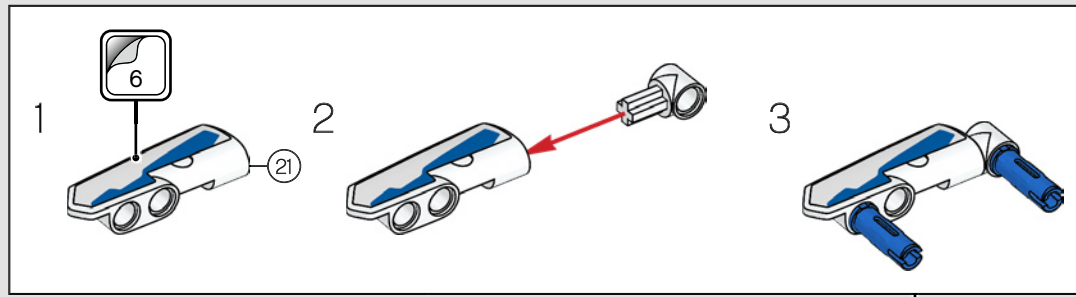

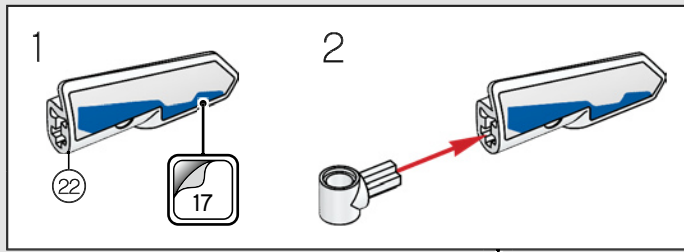
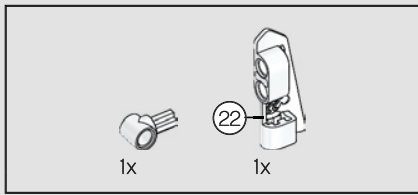

416

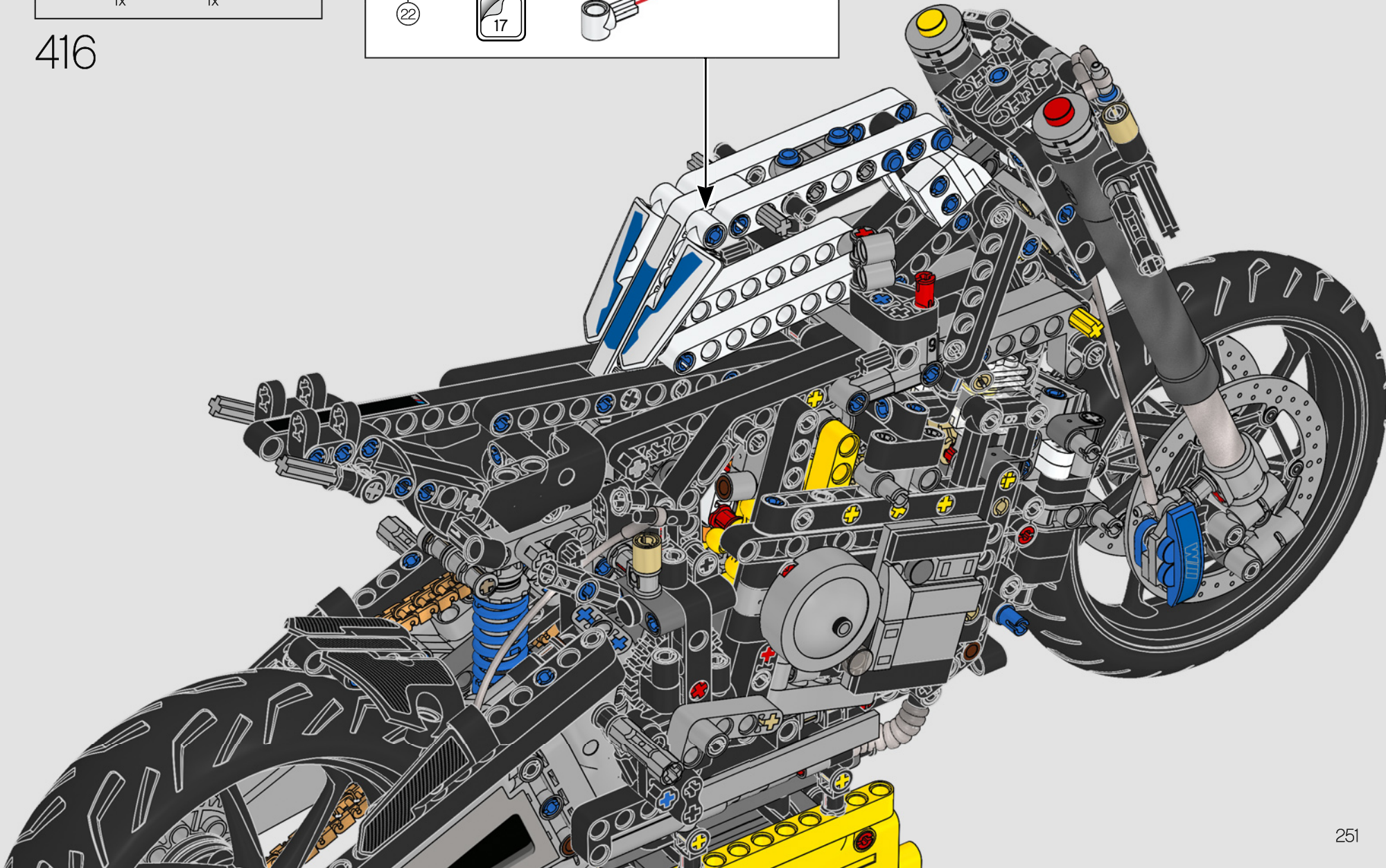



417

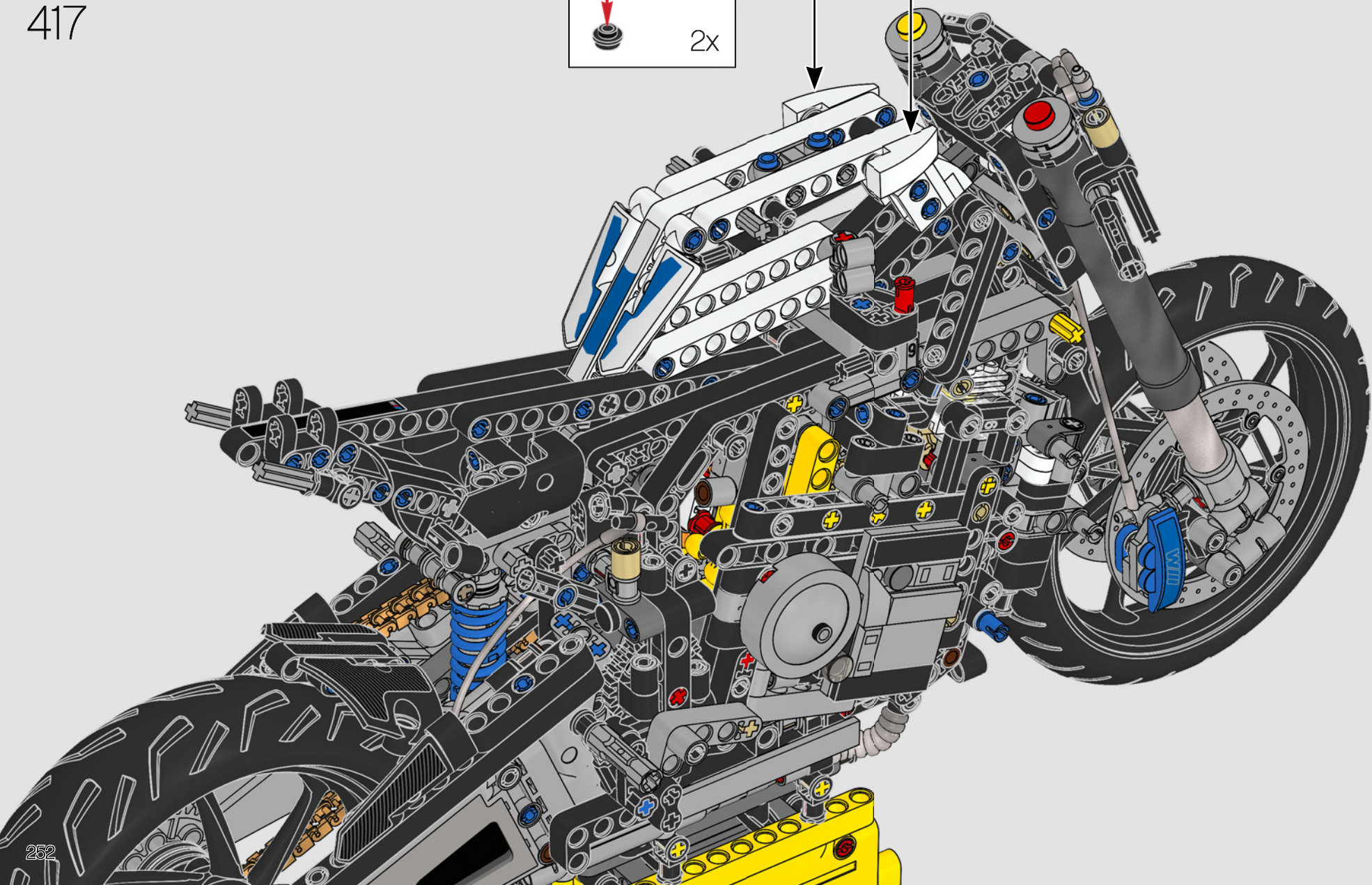
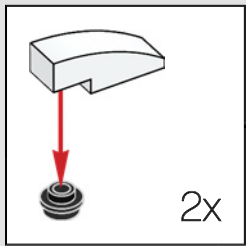



418

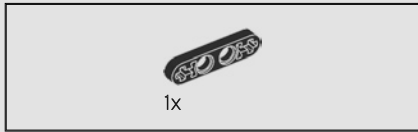

419

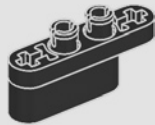

420

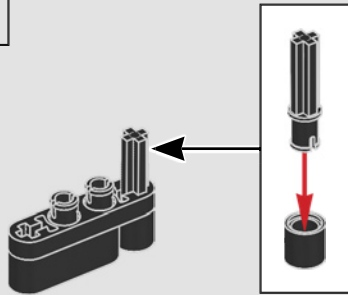

421

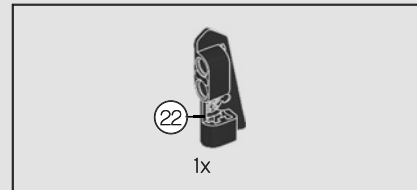
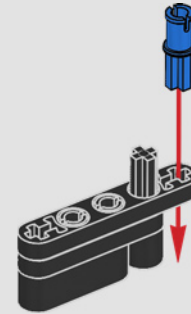

422

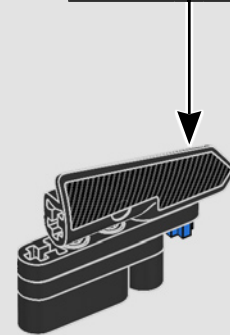
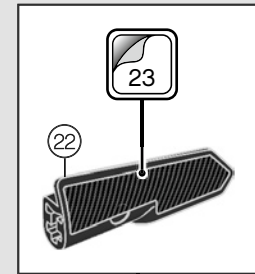

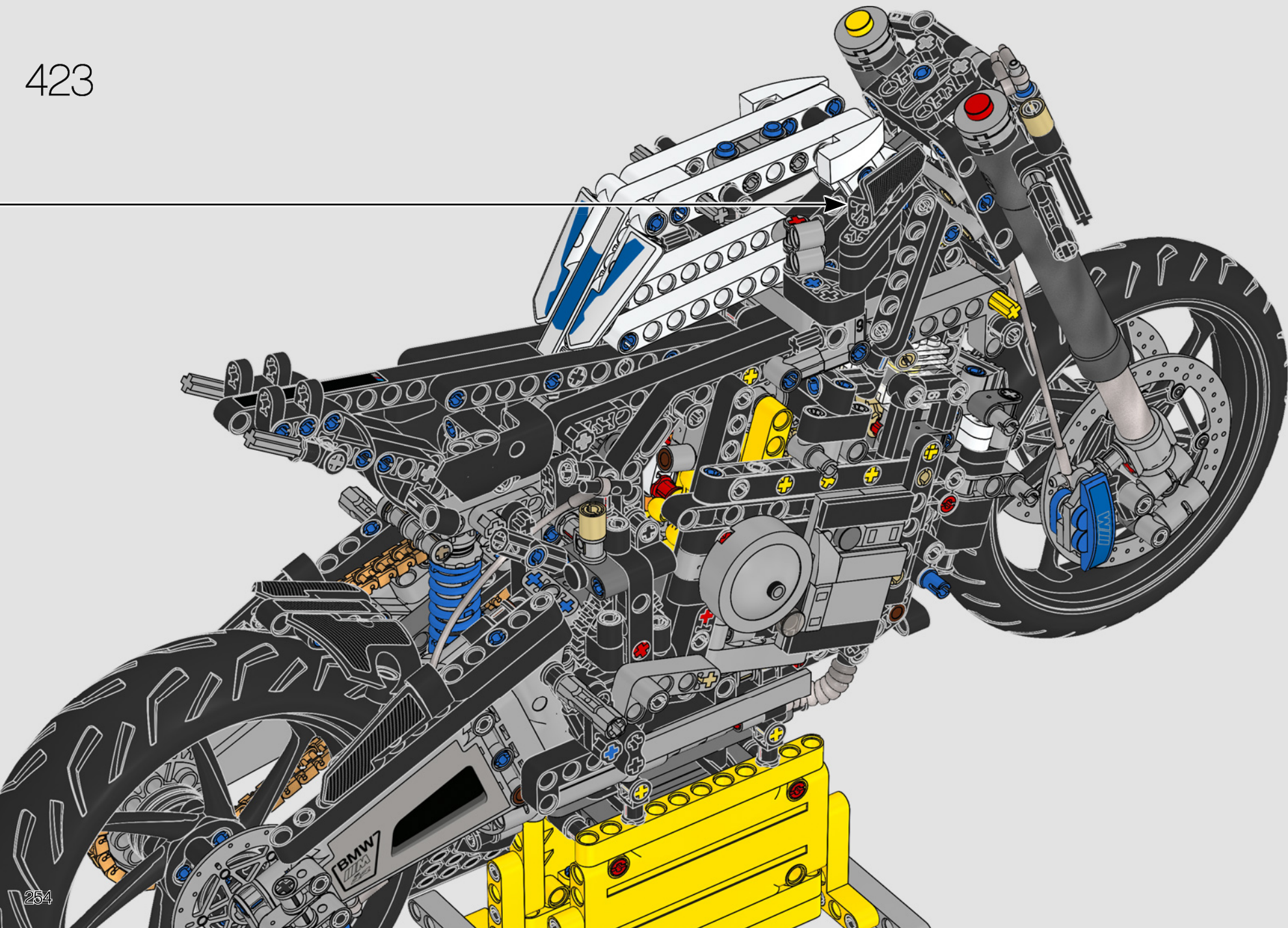

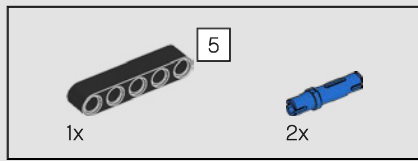

424

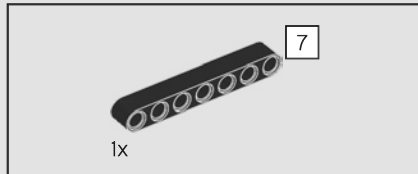
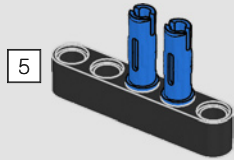

425

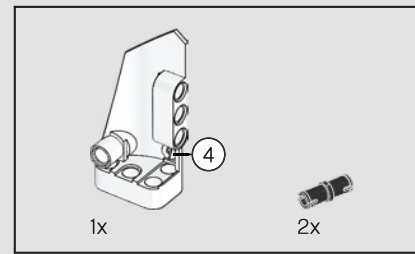
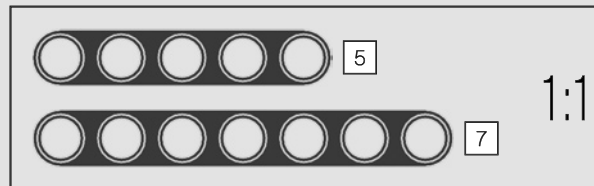
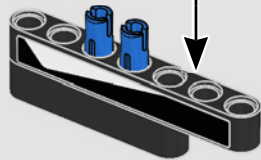
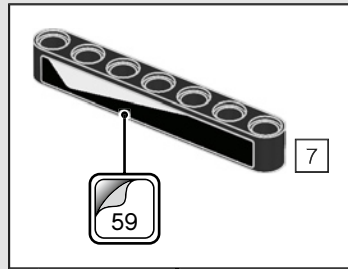

426

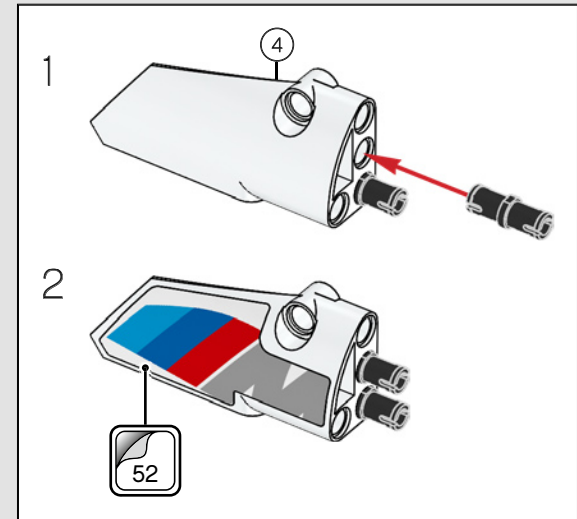

427

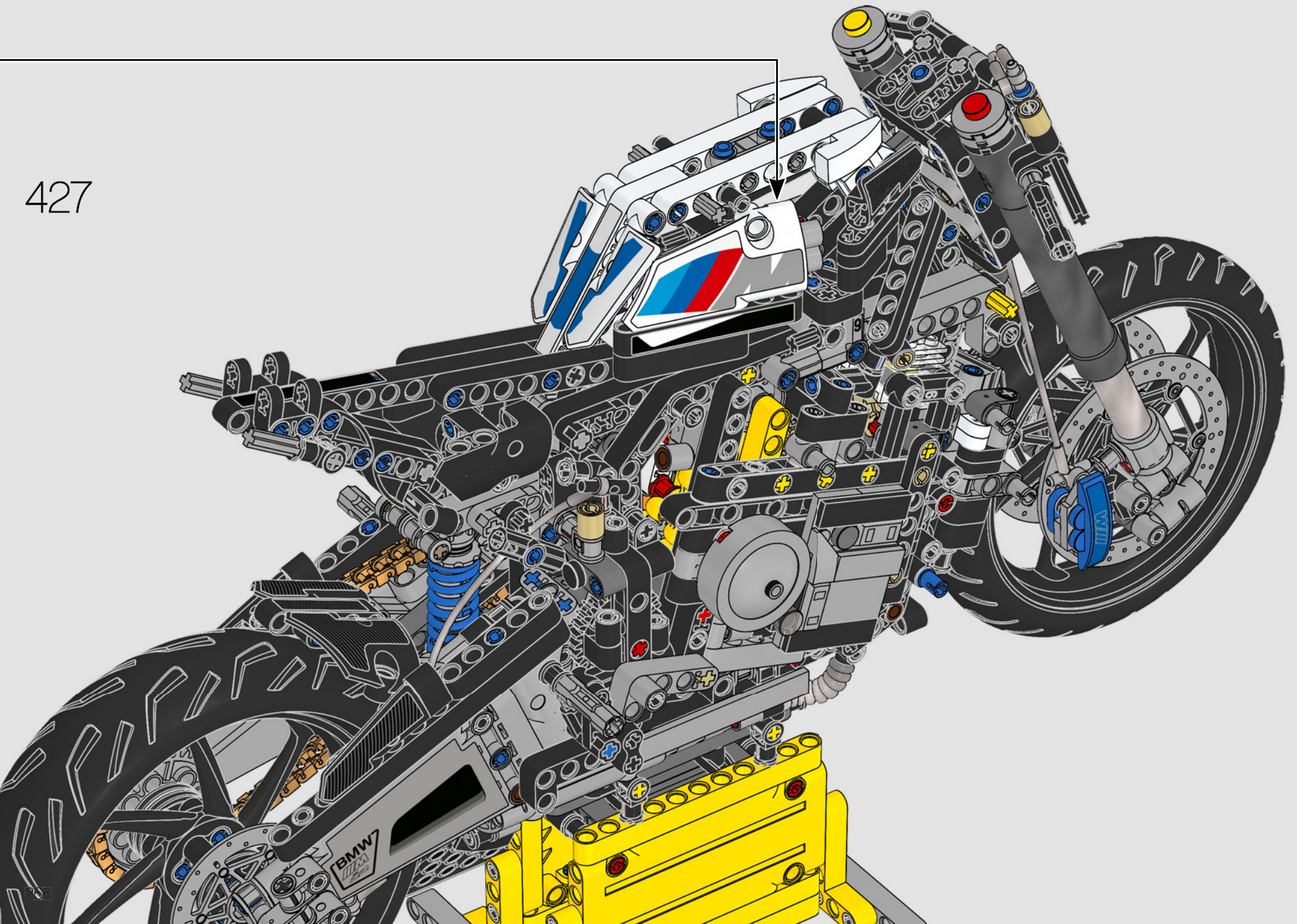

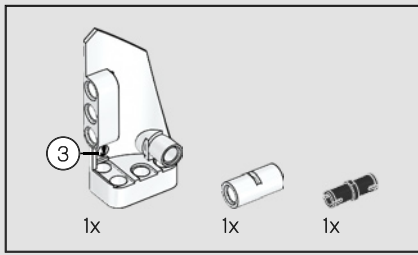

428

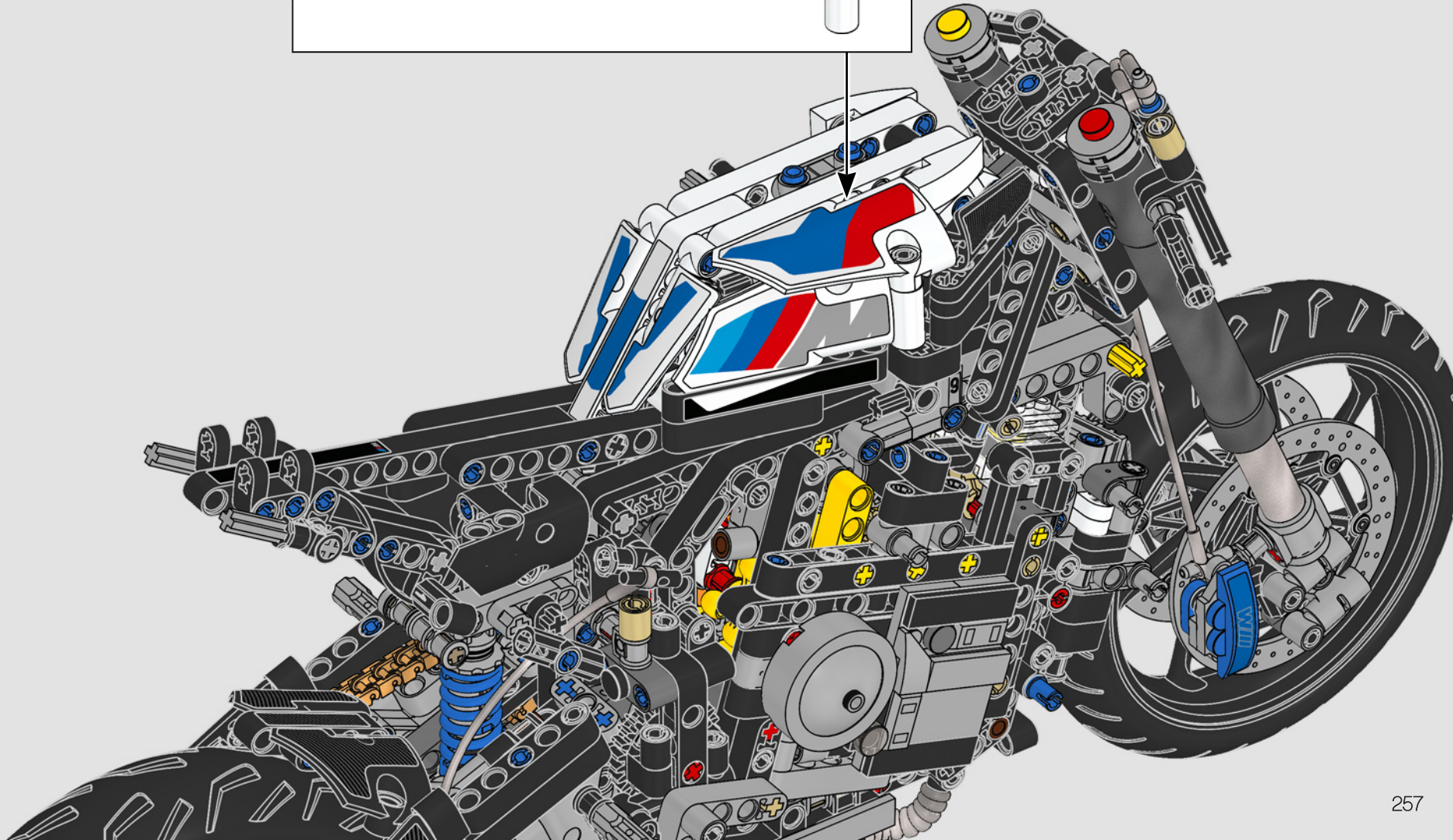
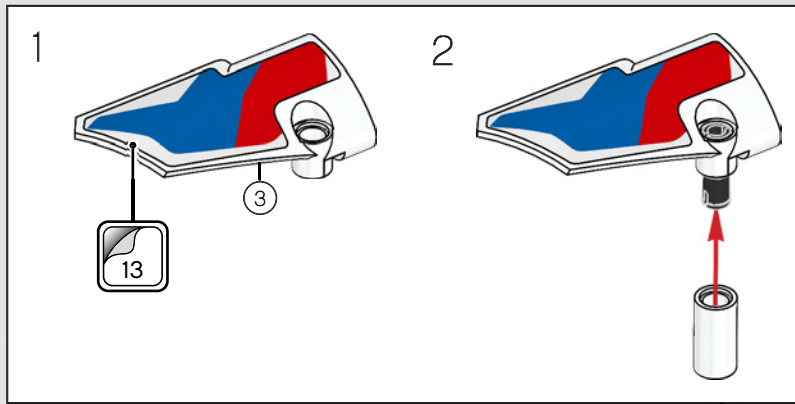

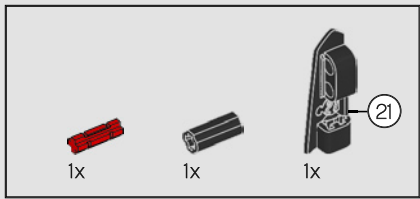

429

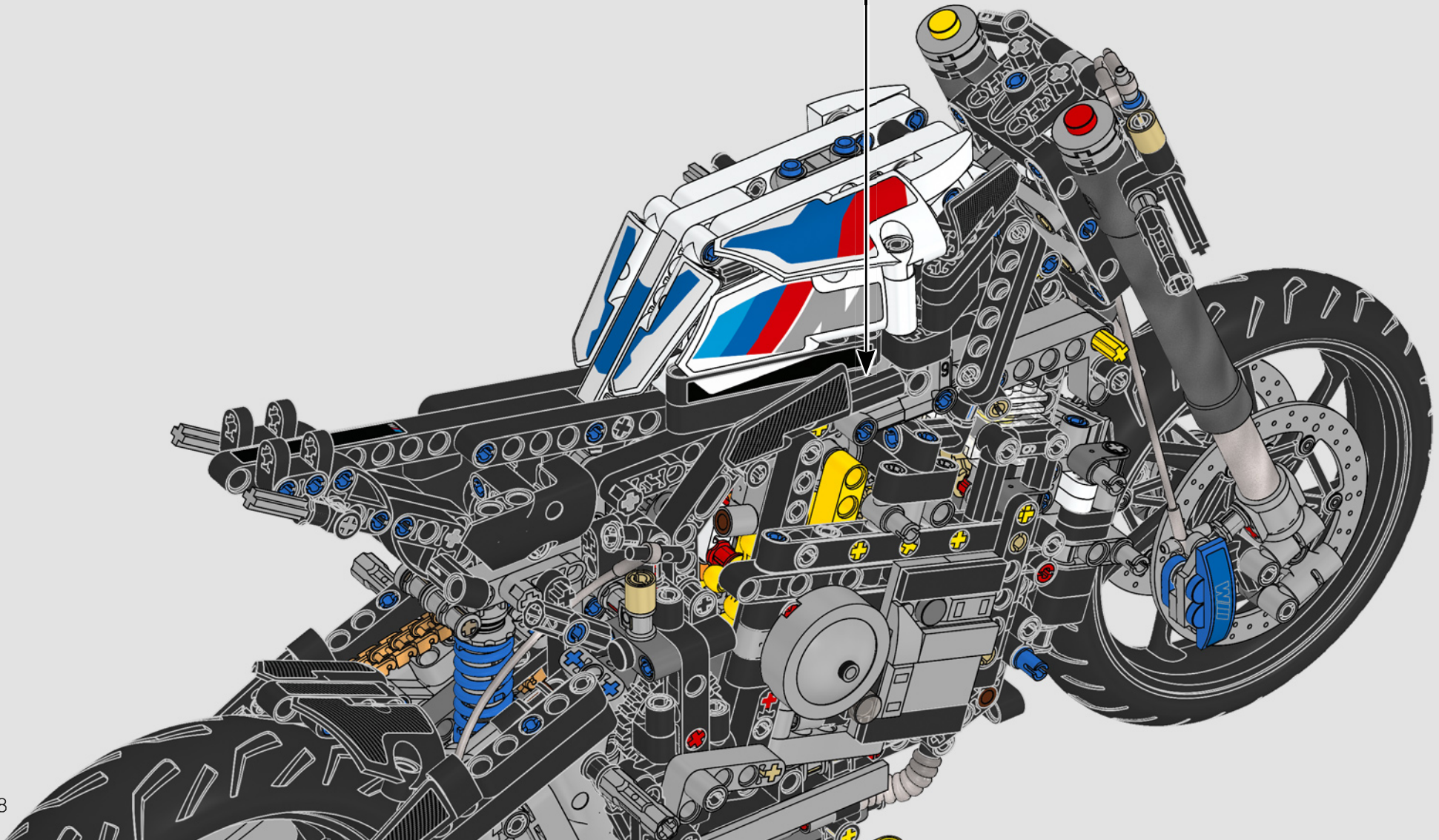
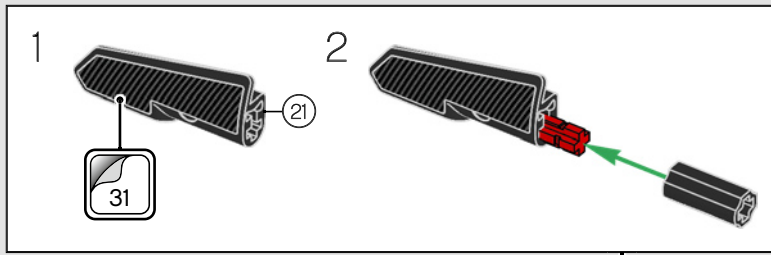

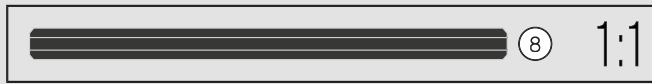
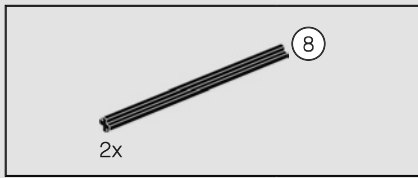

430

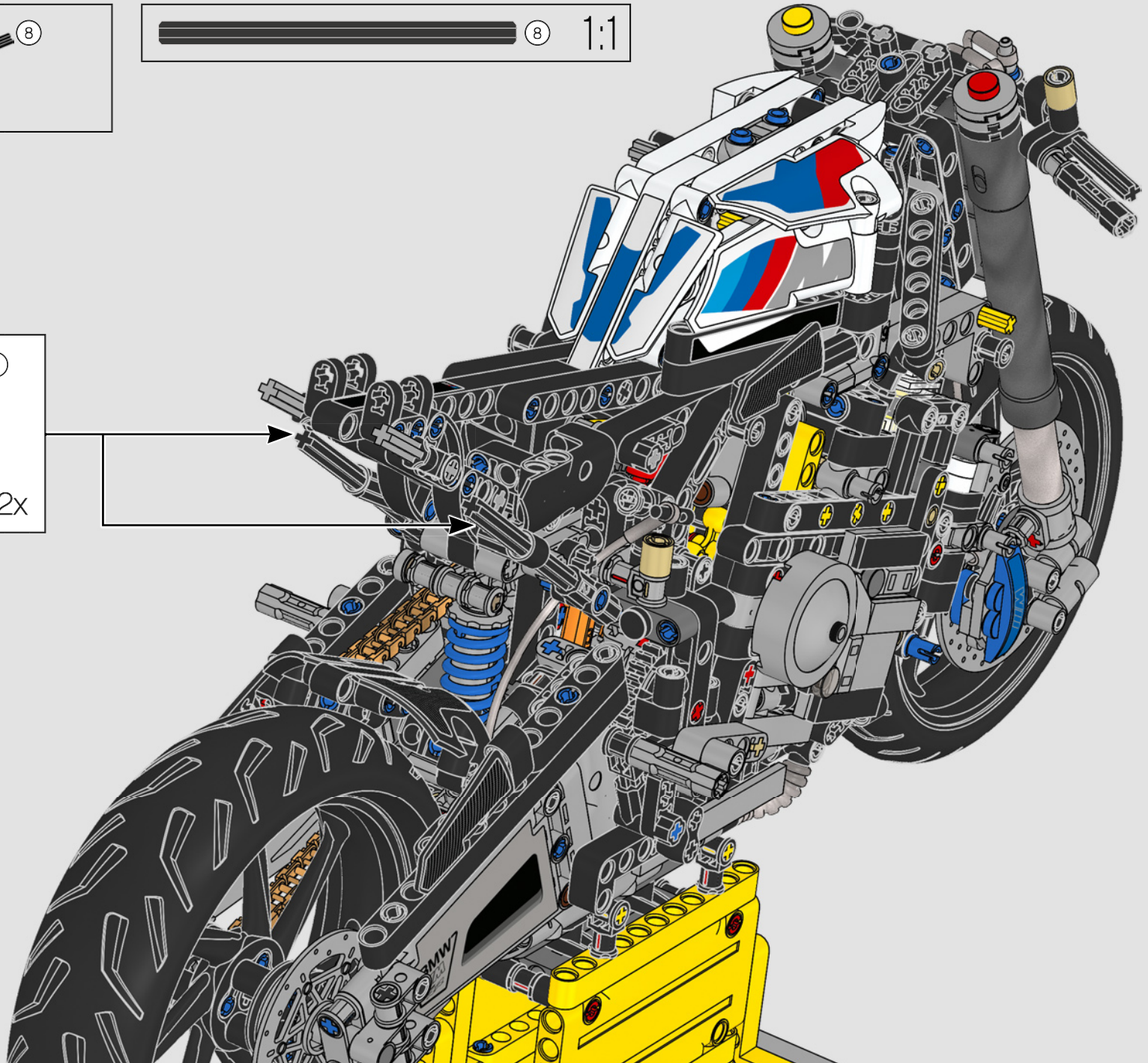
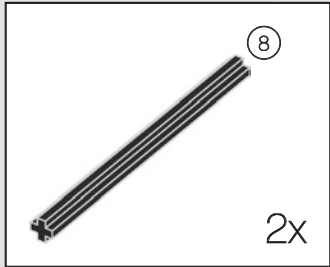

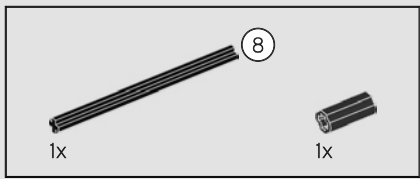

431

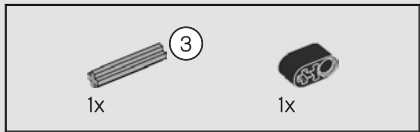
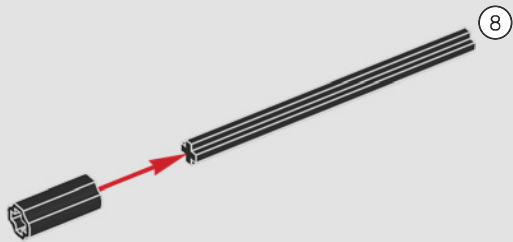

432

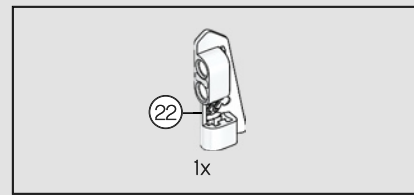
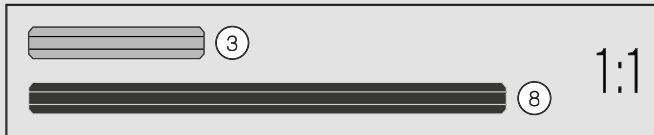
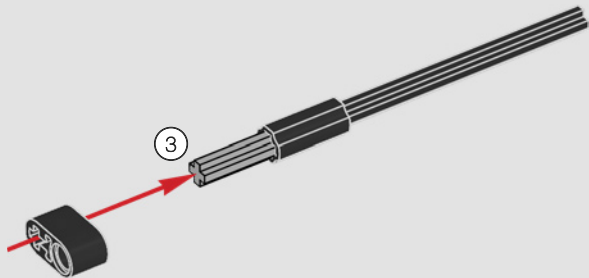

433

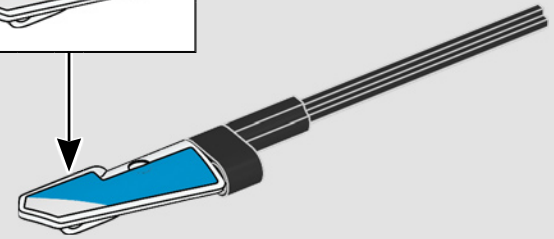
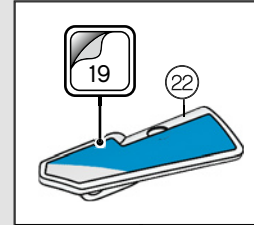

434

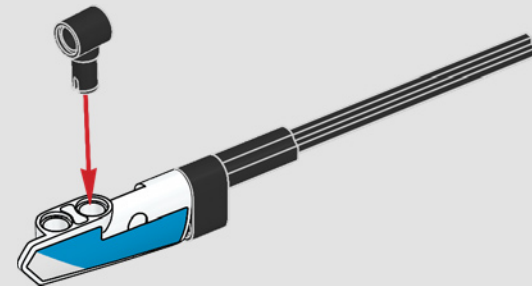

435

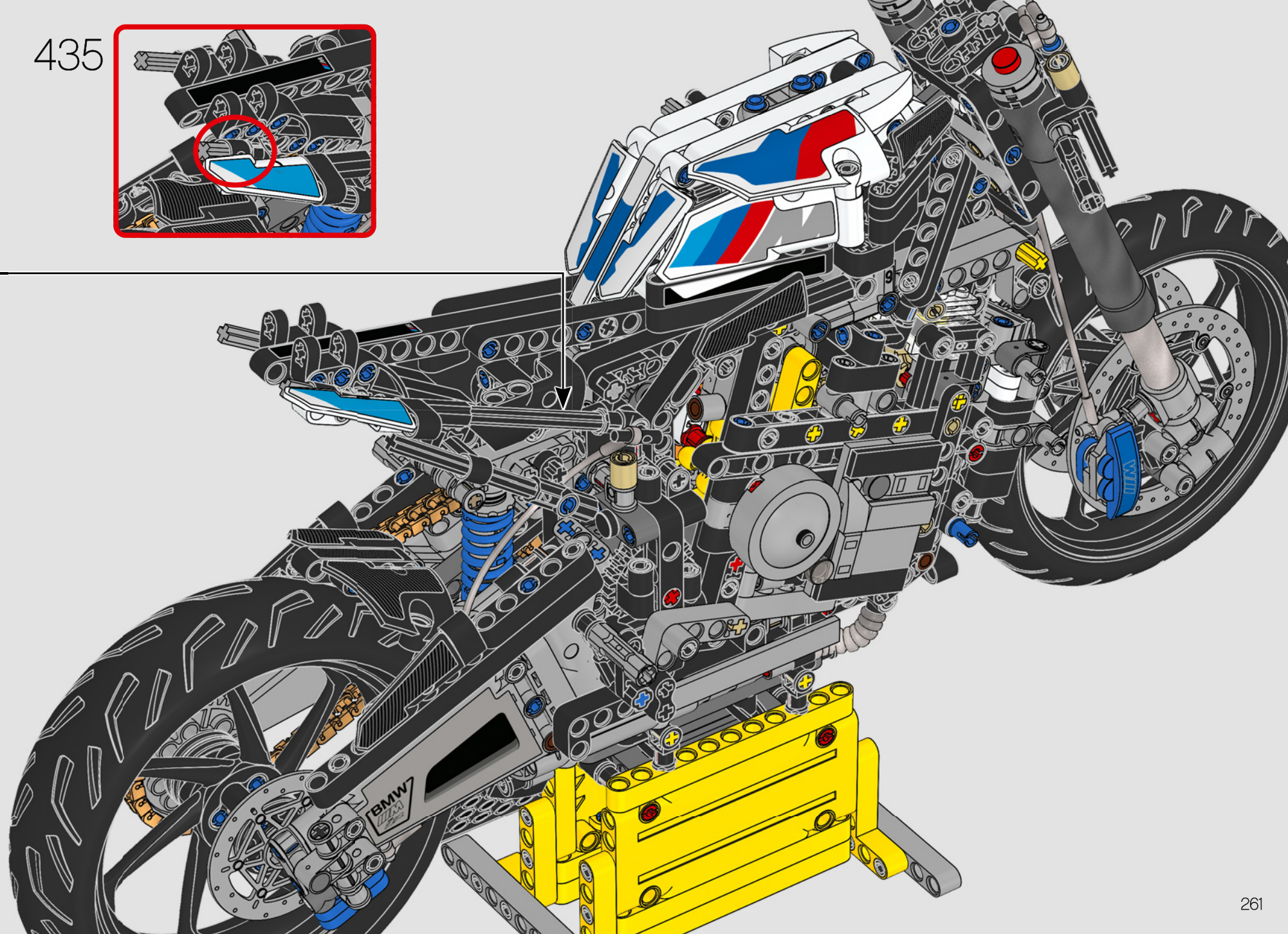
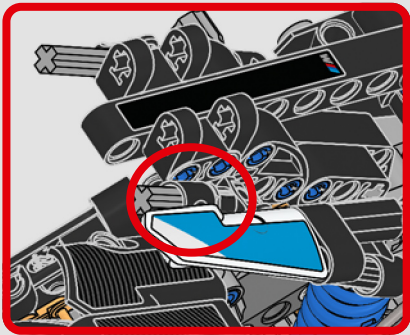

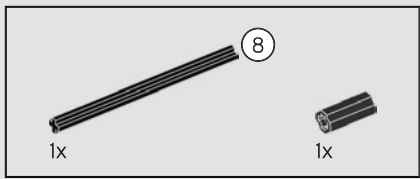

436

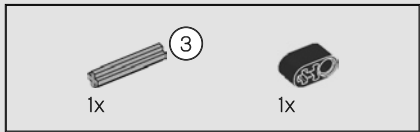
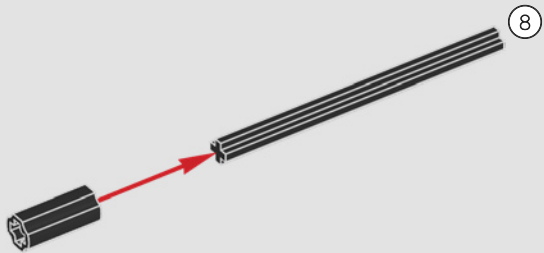

437

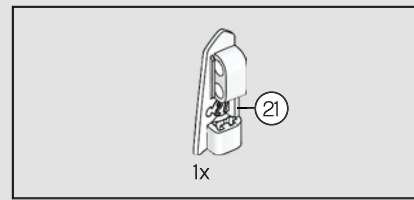
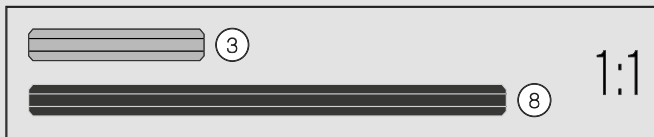
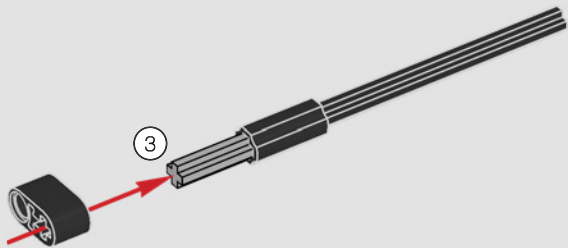

438

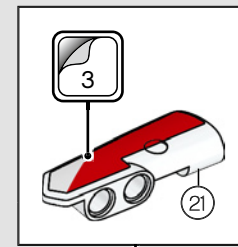
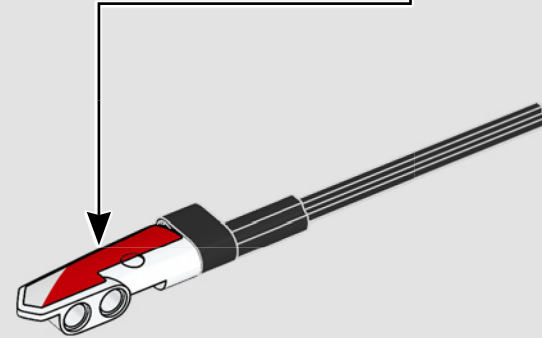

439

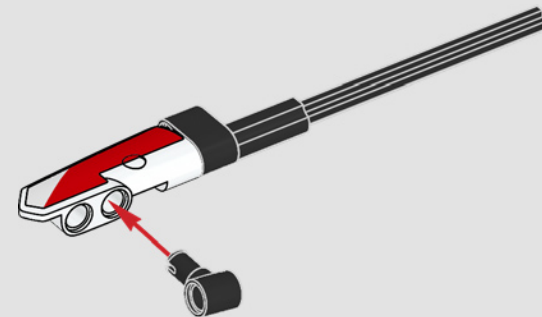

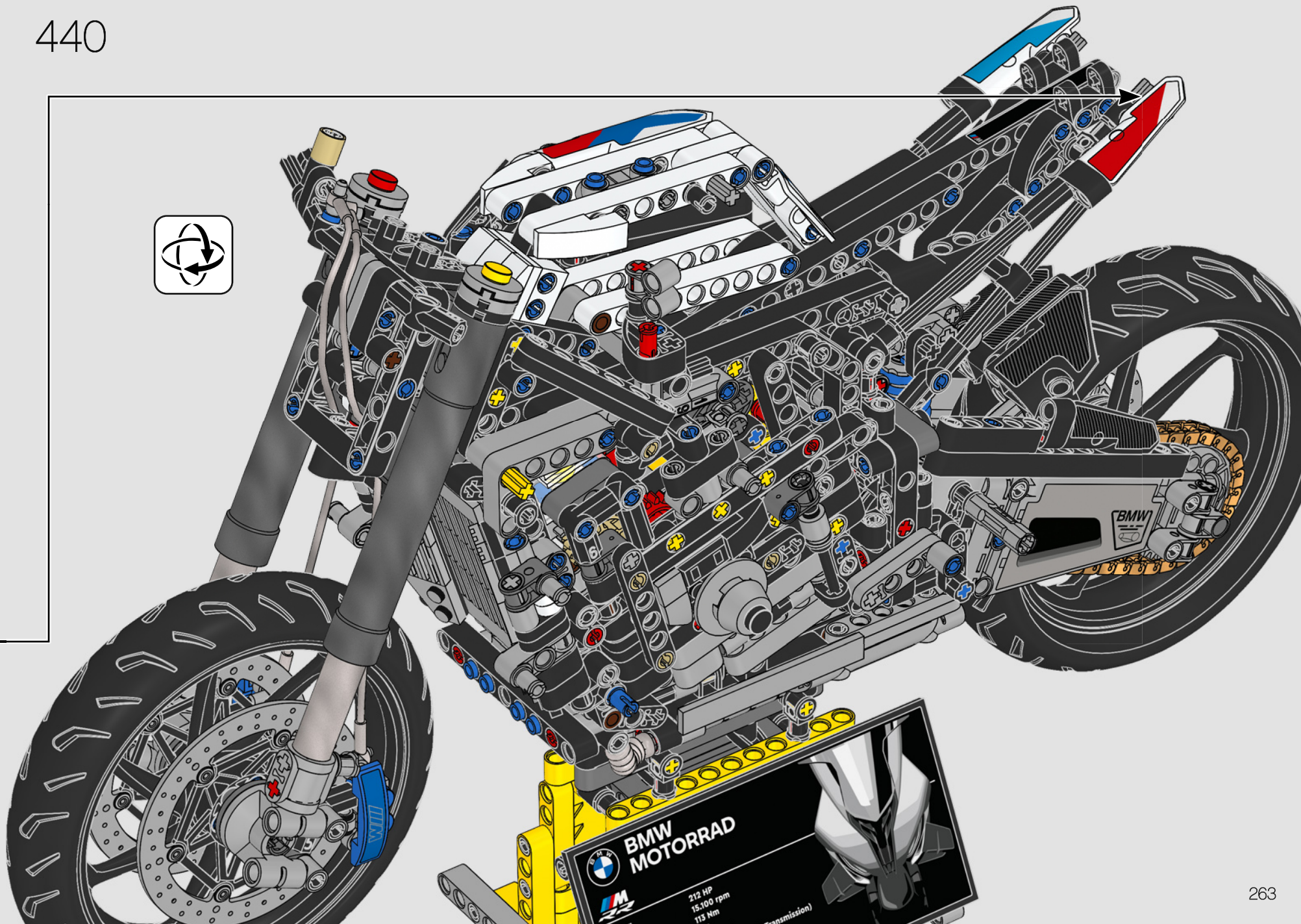

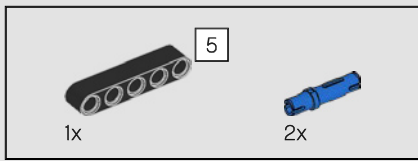

441

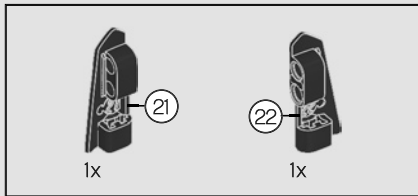
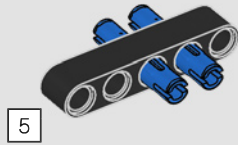

442

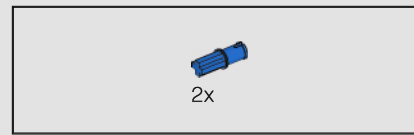
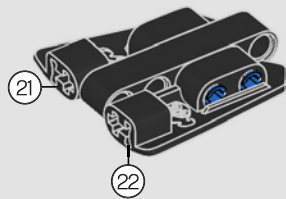

443

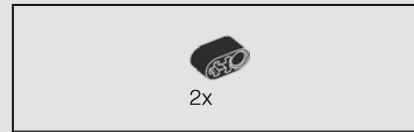
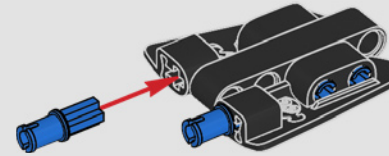

444

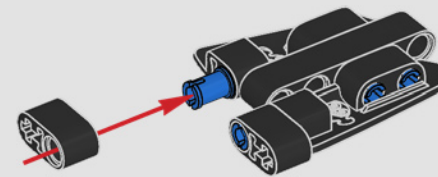

445

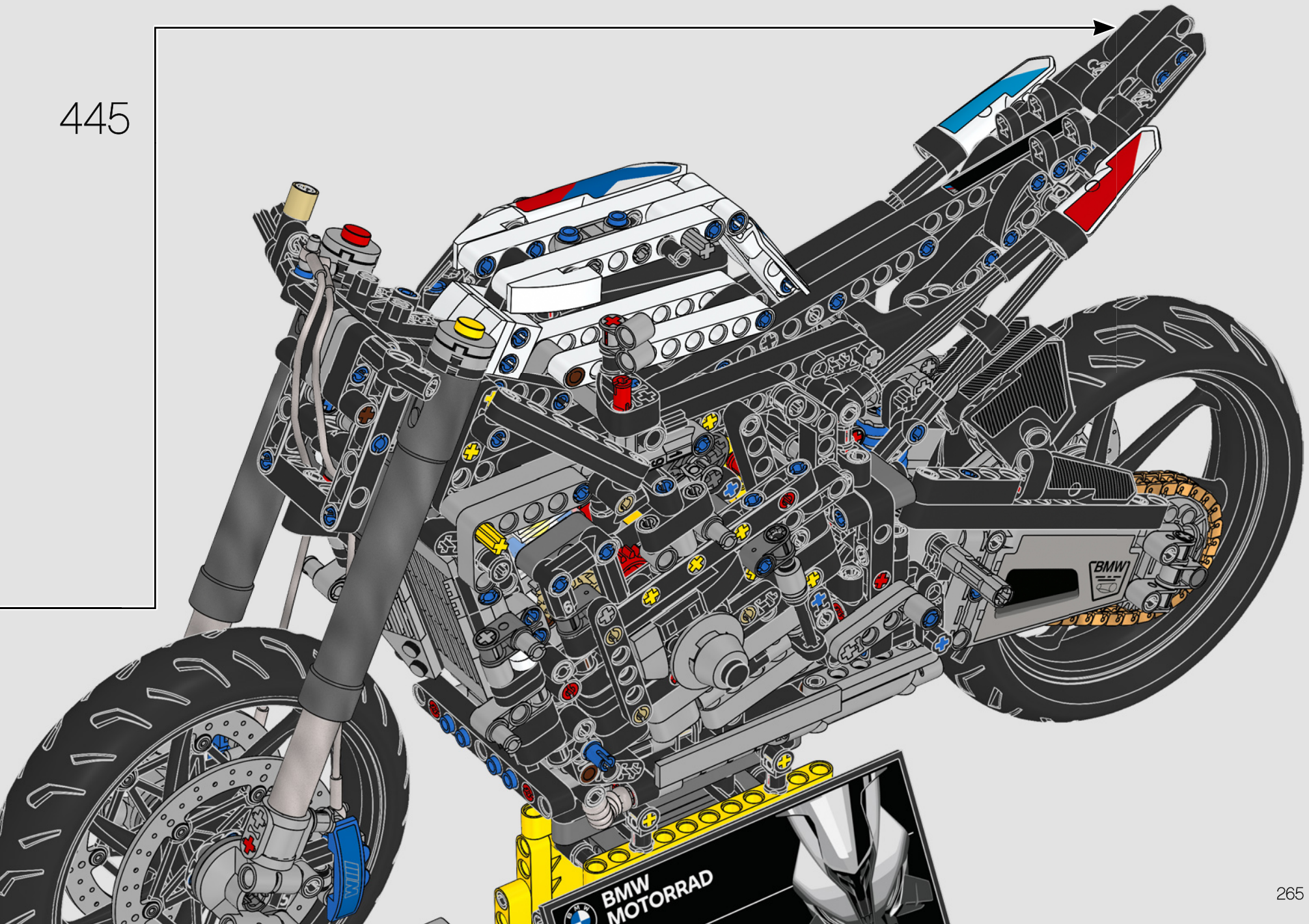

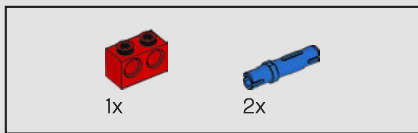

446

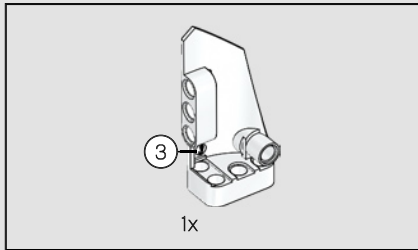
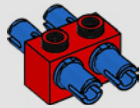

447

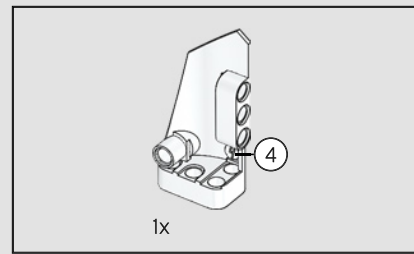
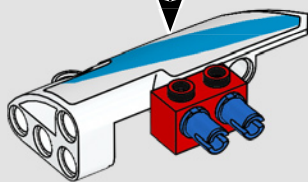
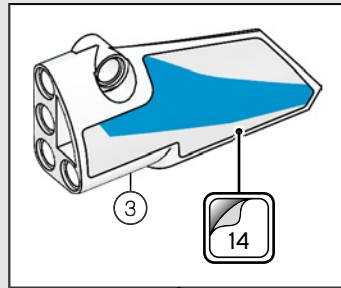

448

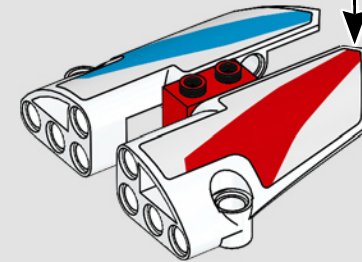
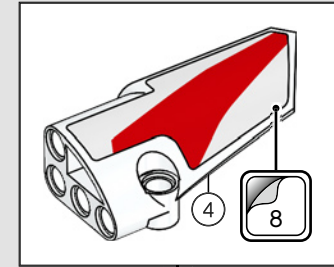

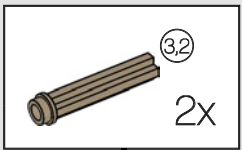
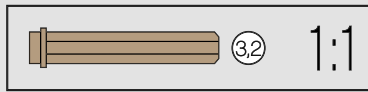
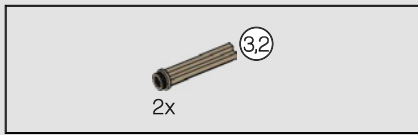

449

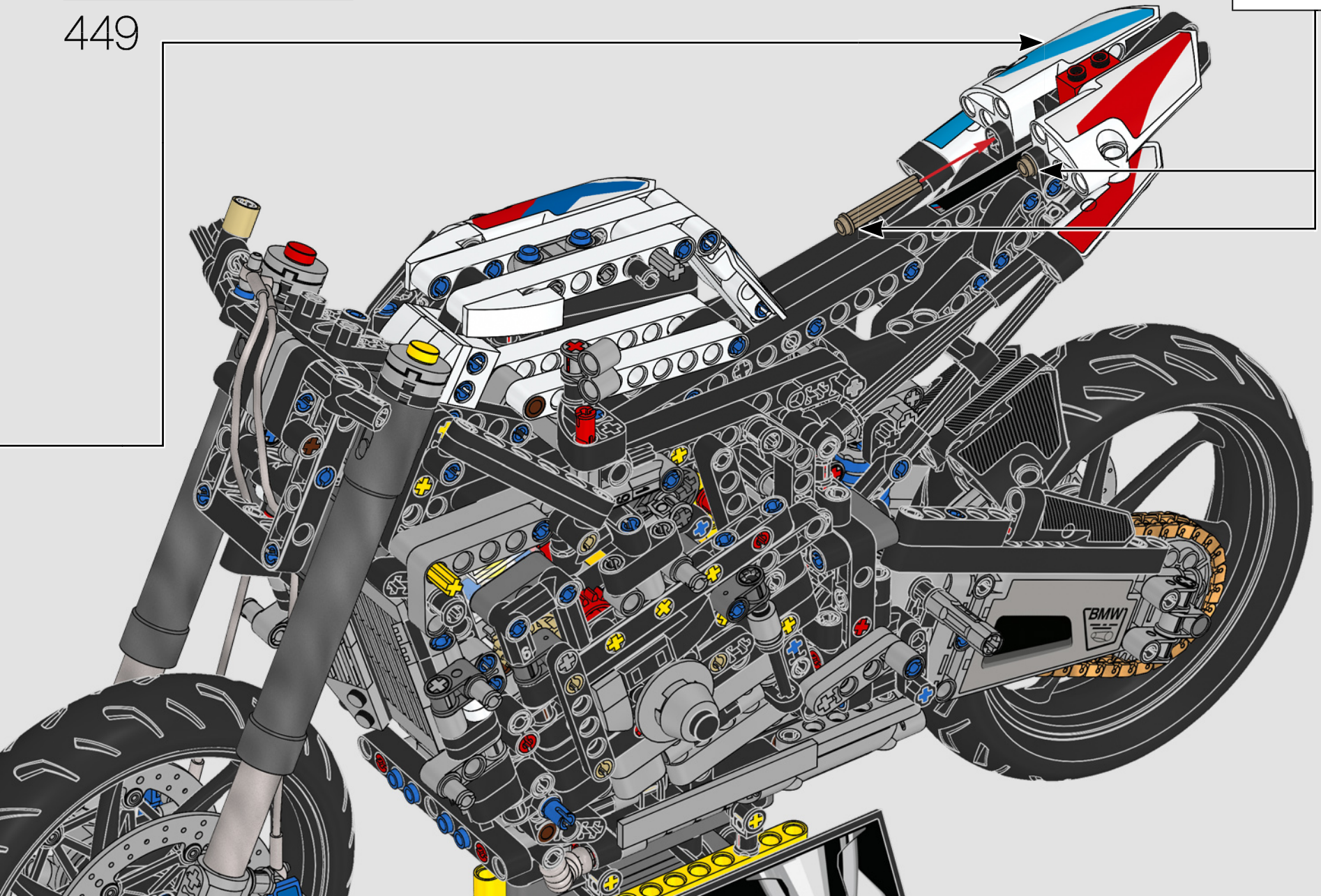

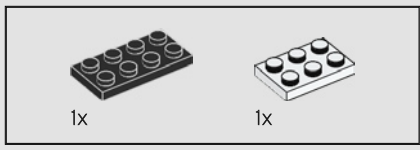

450

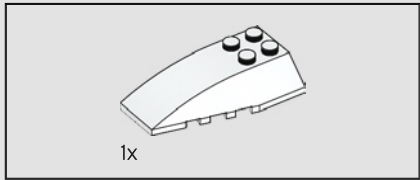
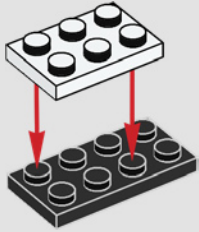

451



452

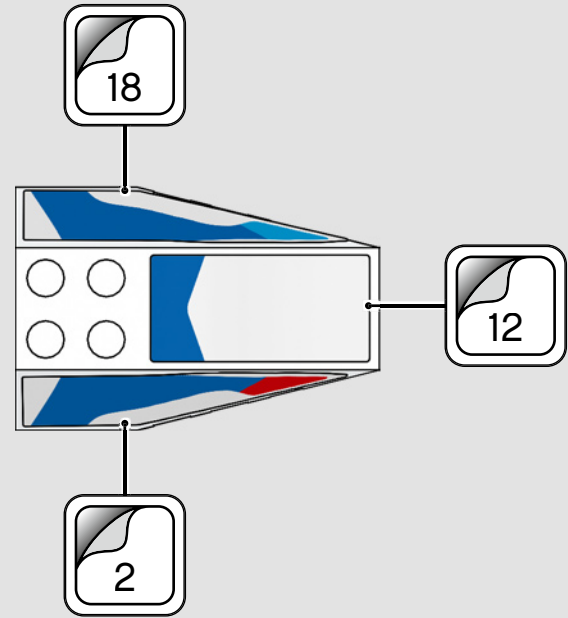

453

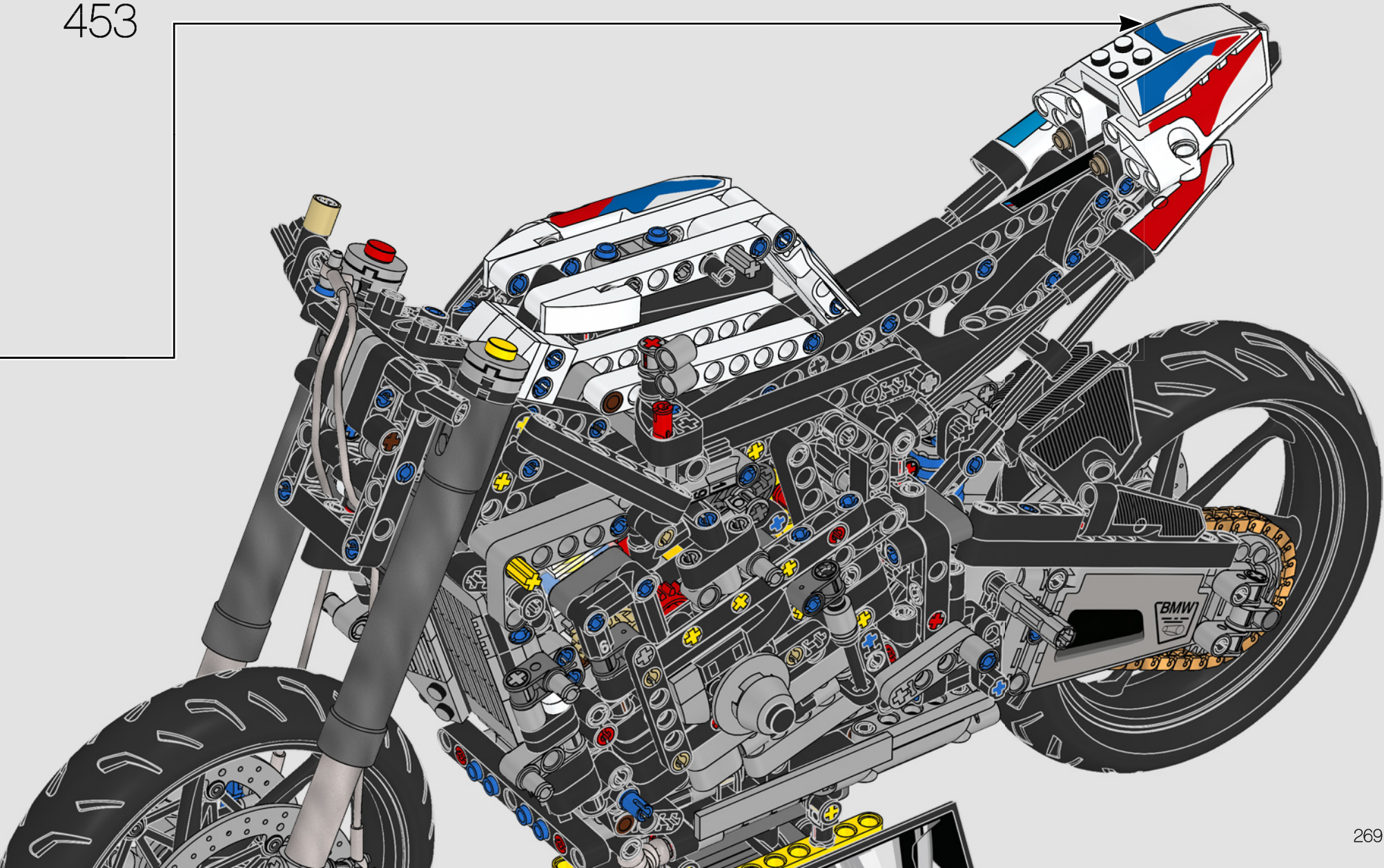

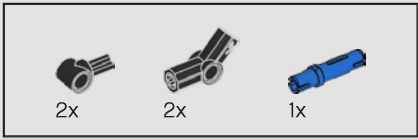

454

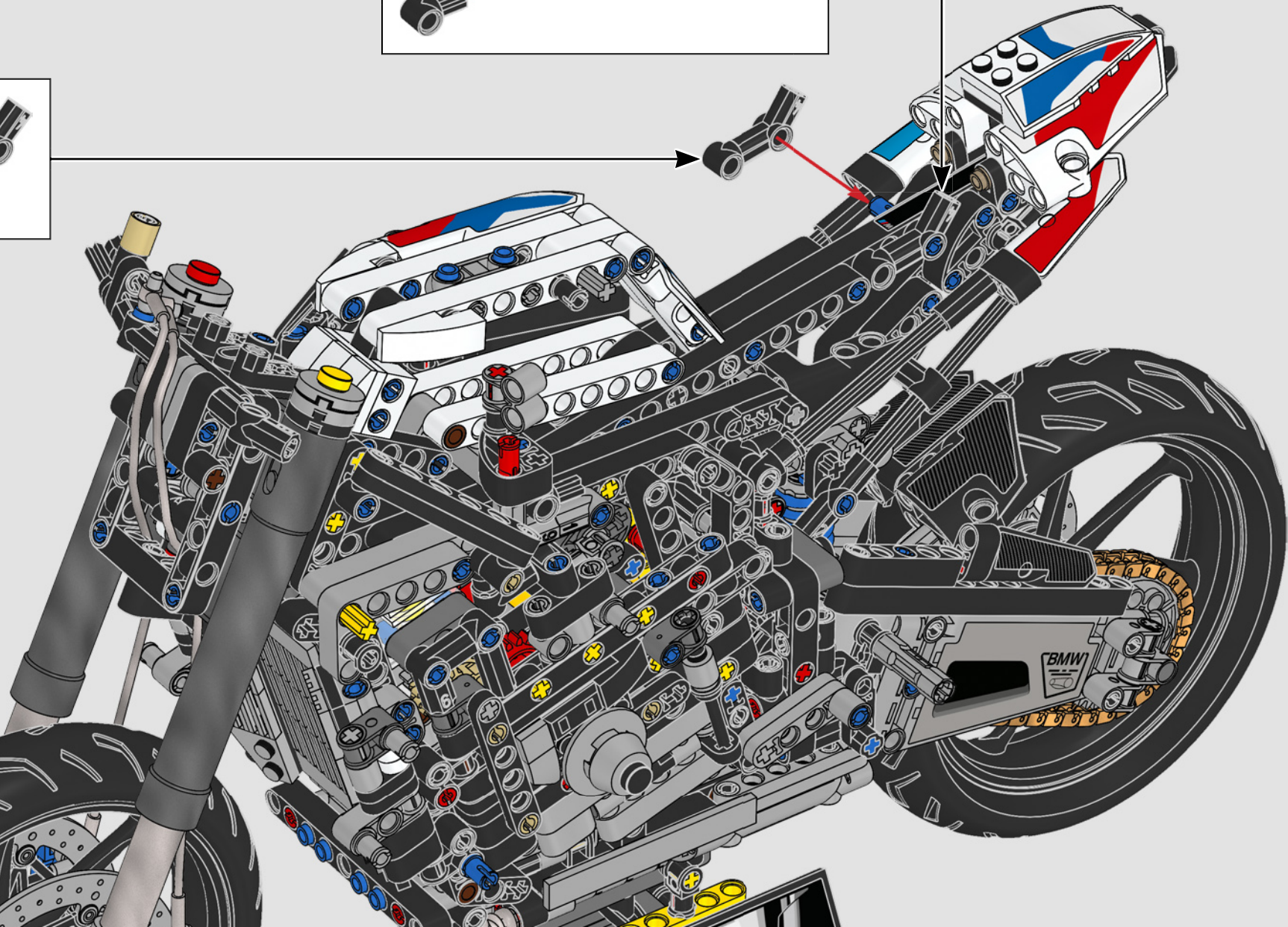
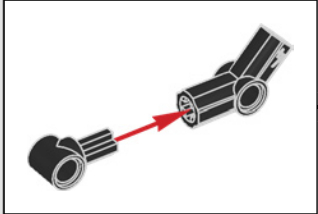
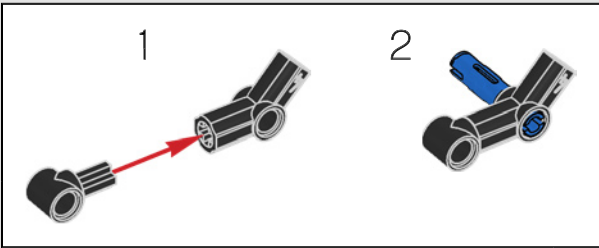

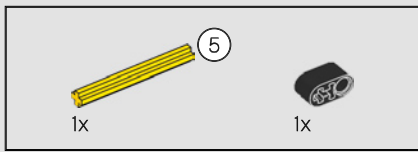

455



456

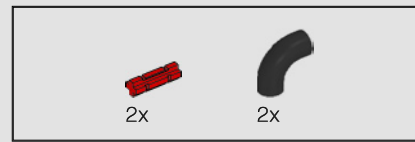
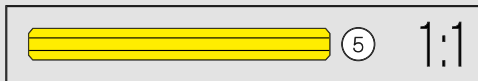
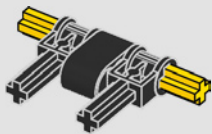

457

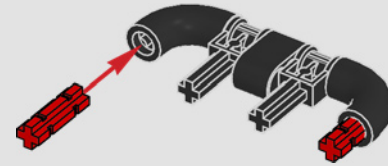

458

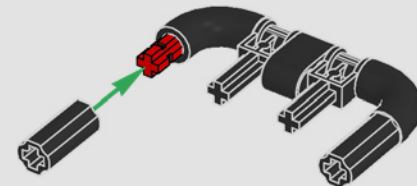

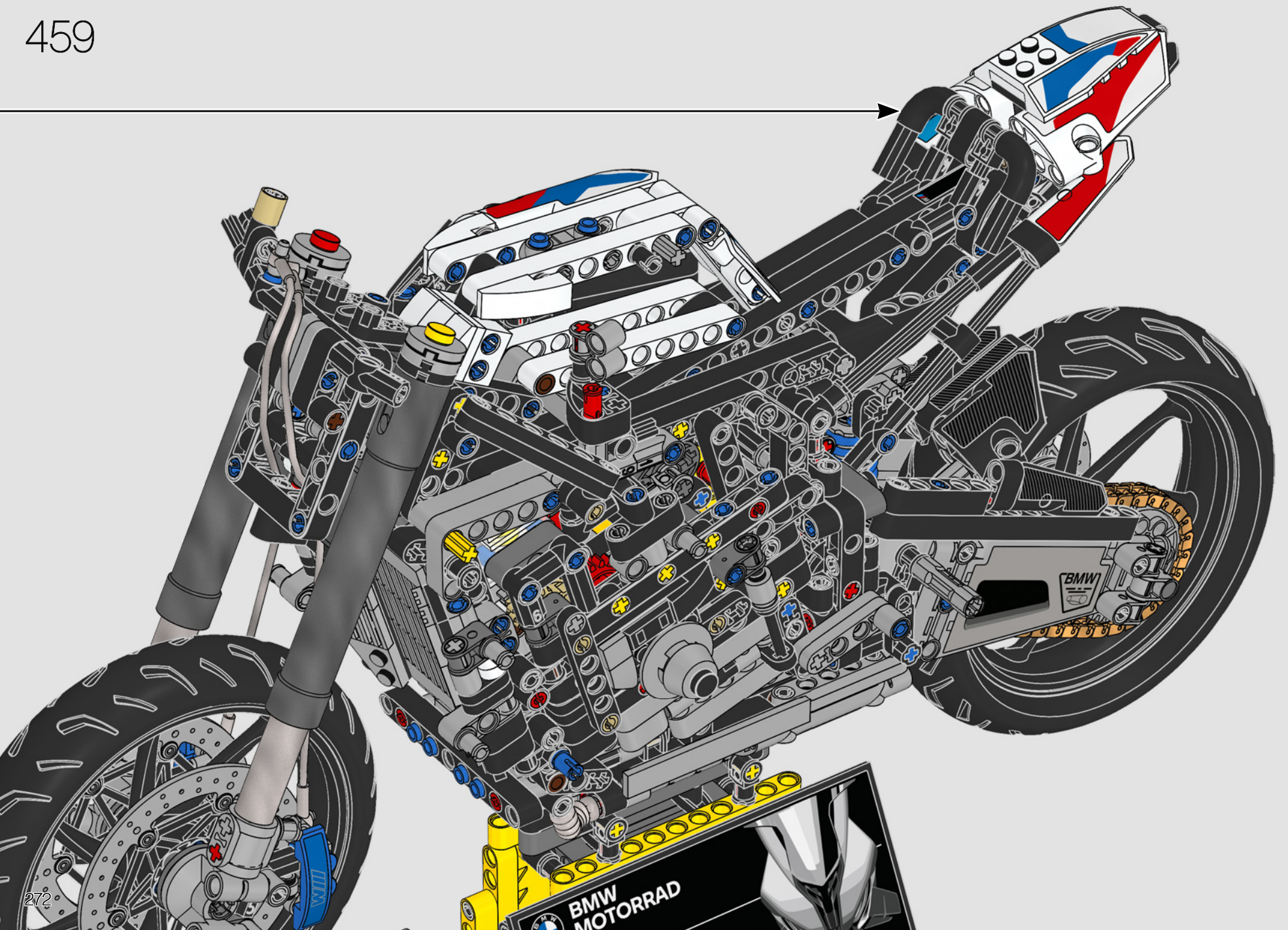

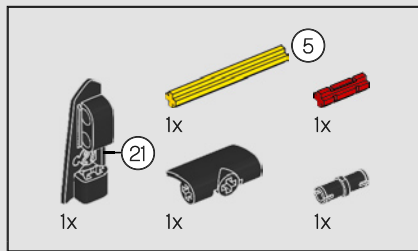

460

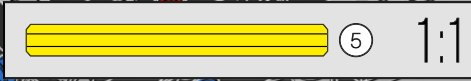
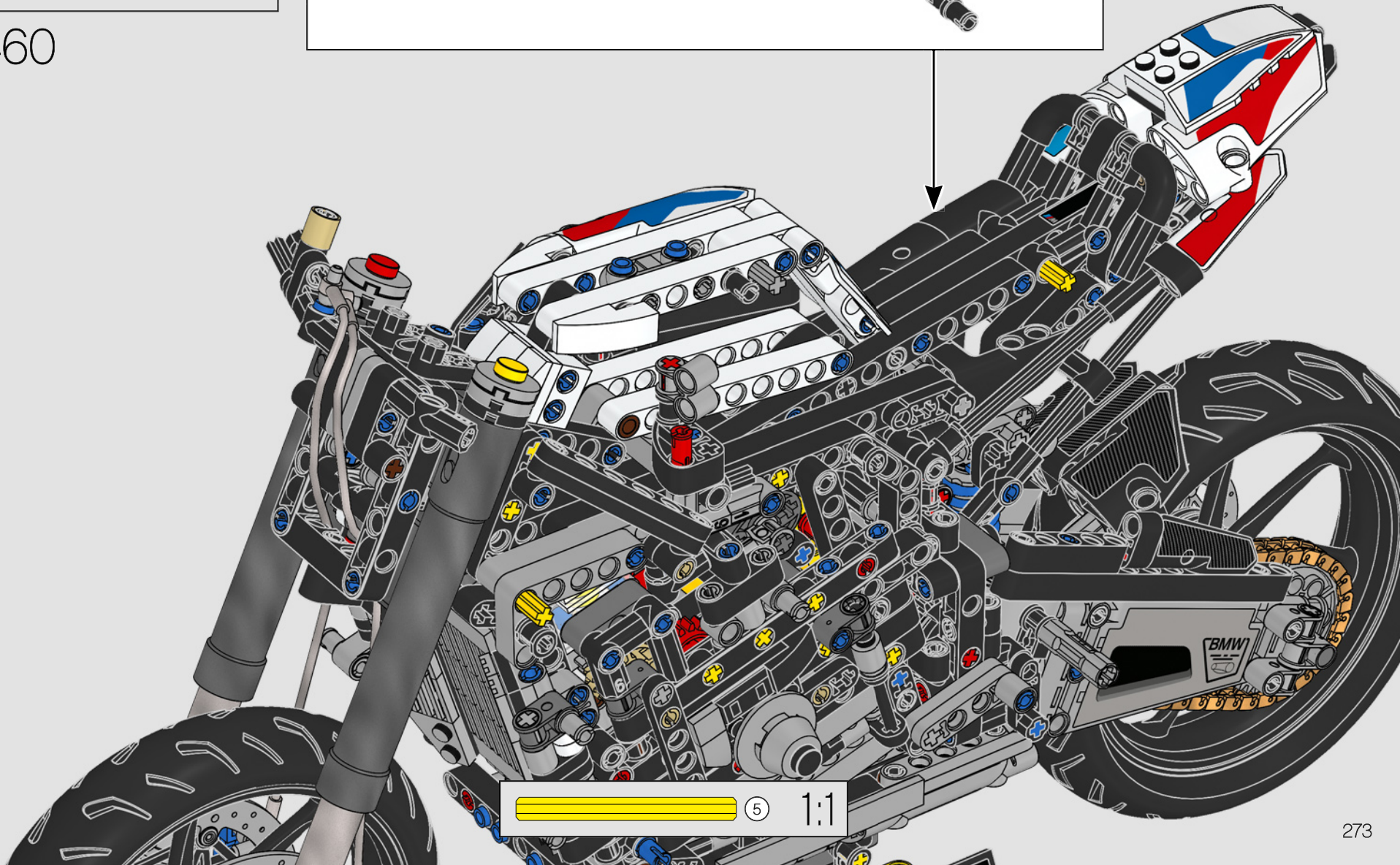
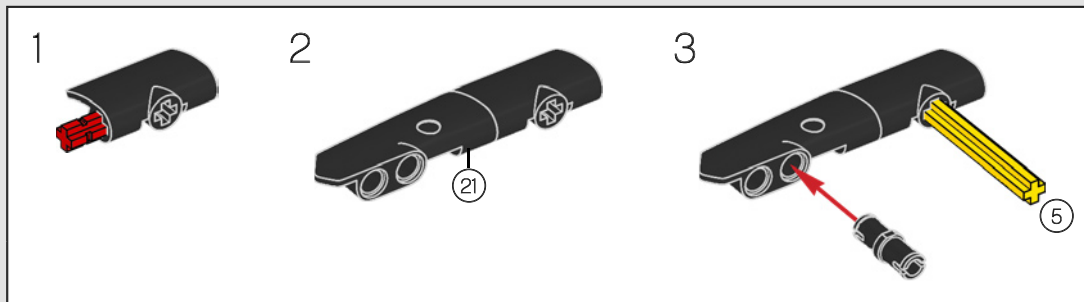

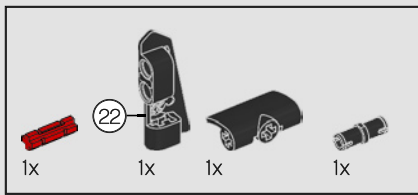

461

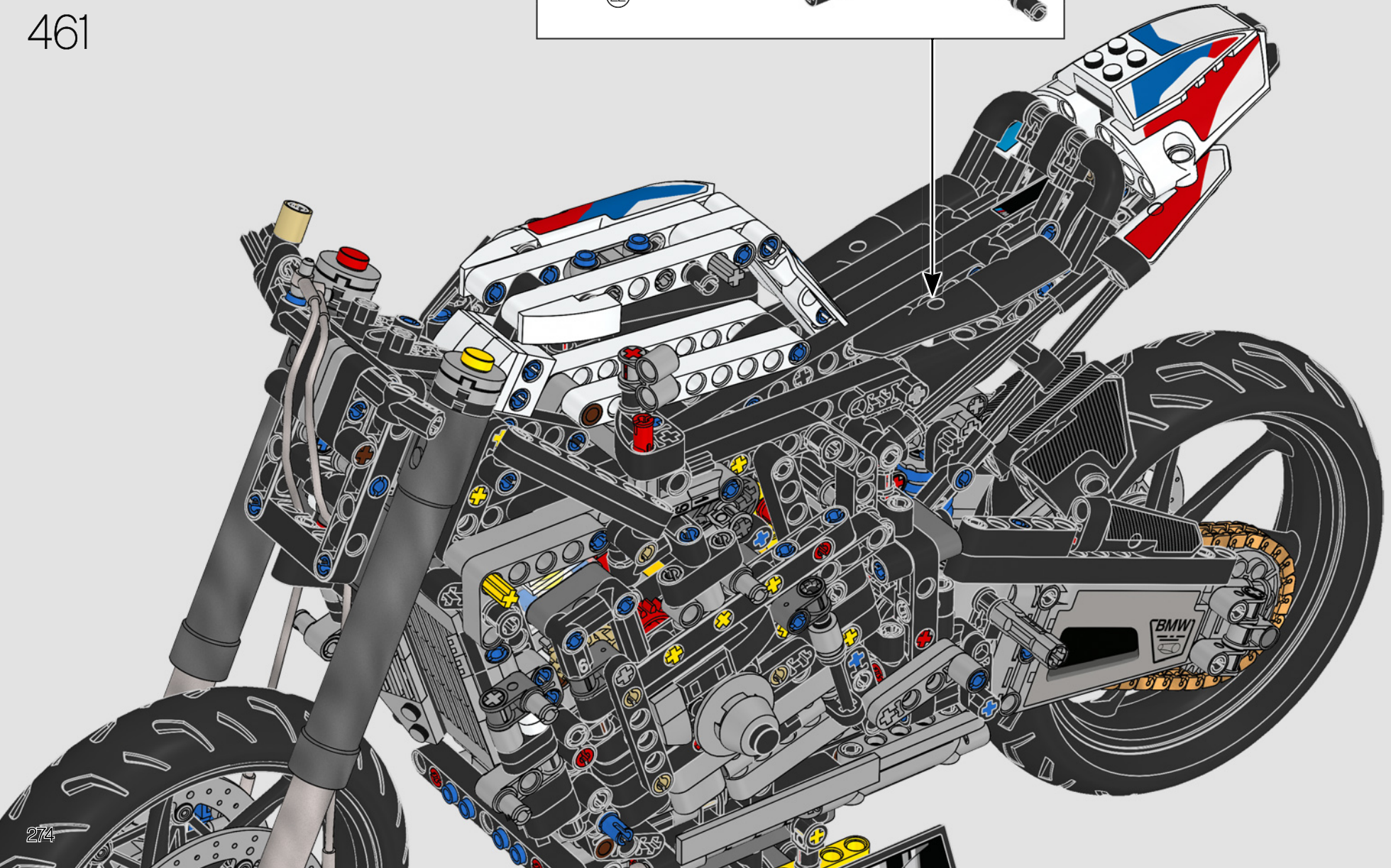
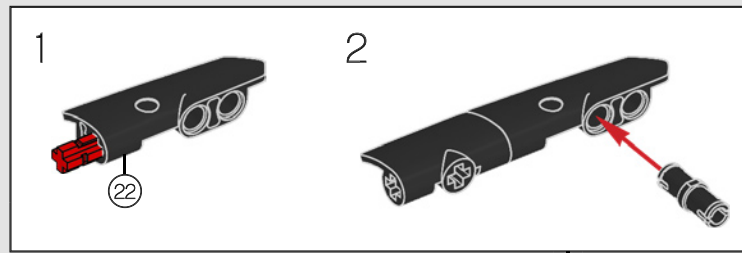

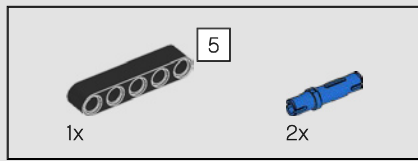

462

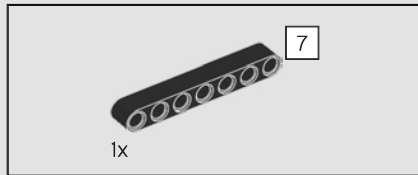
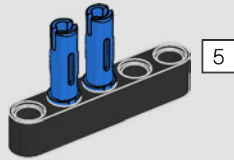

463

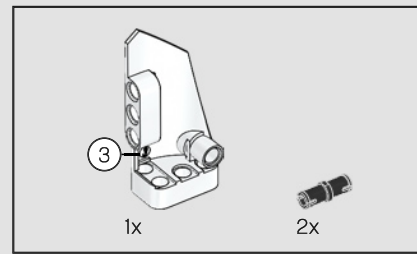
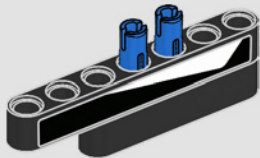
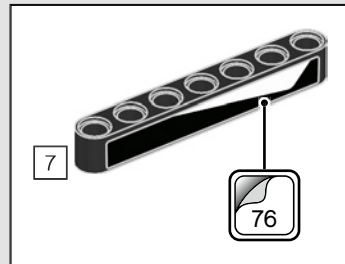

464

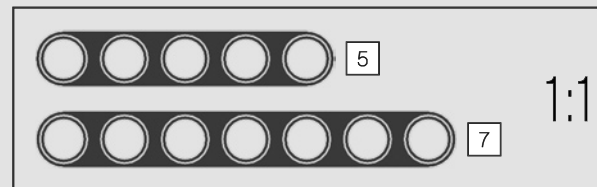
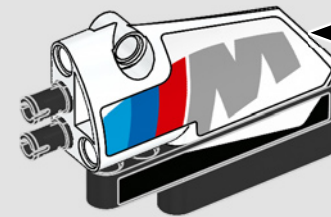
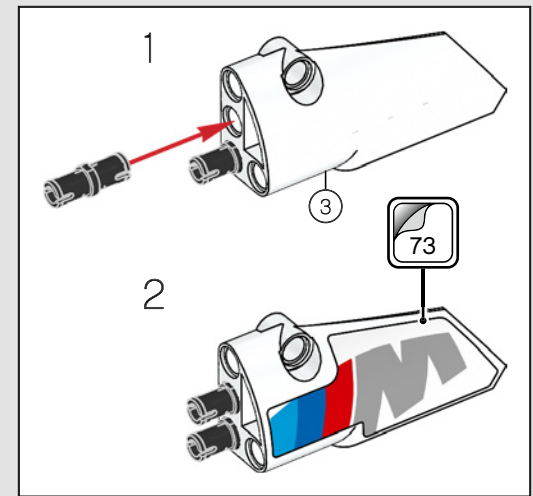

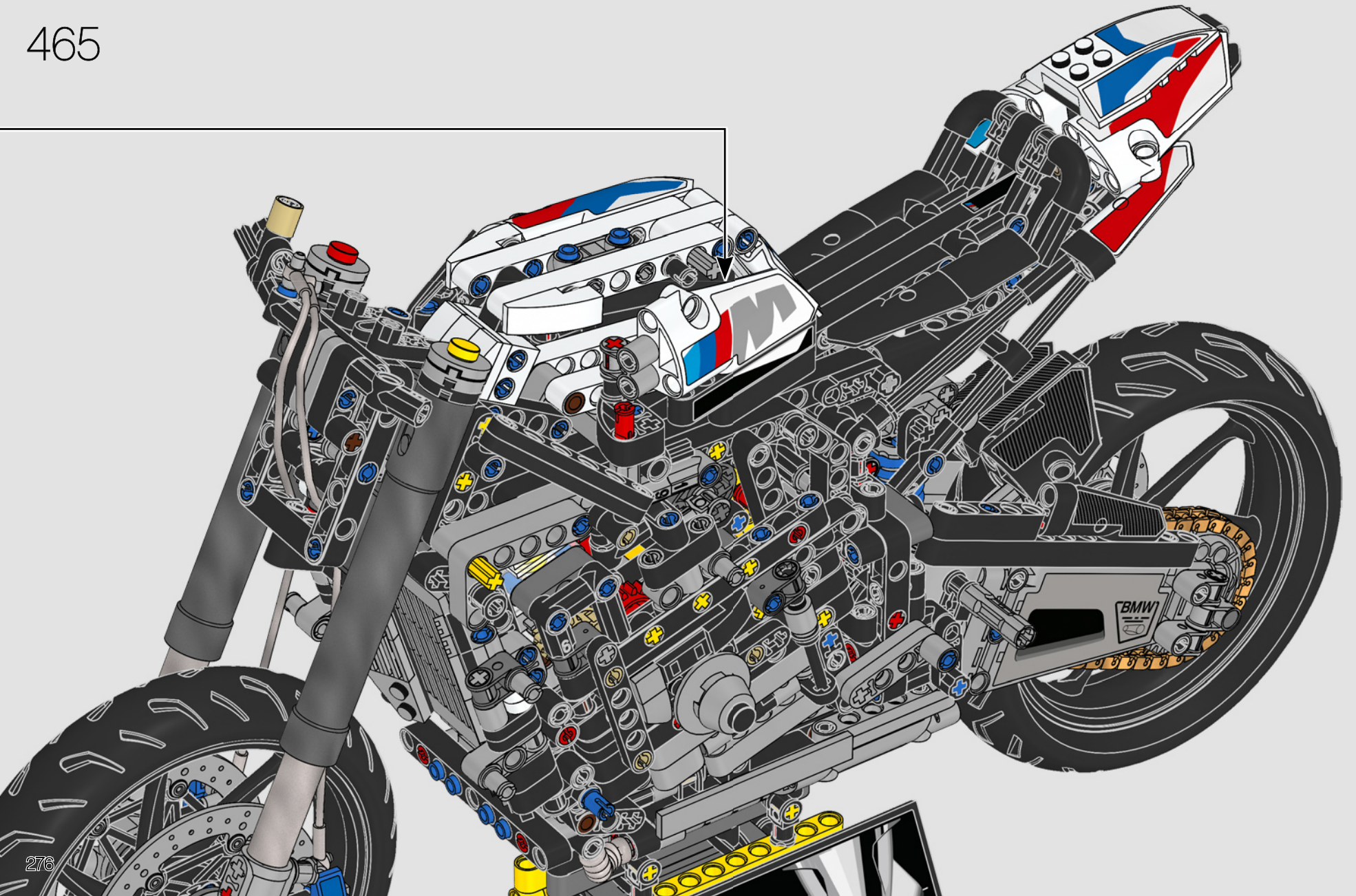



466

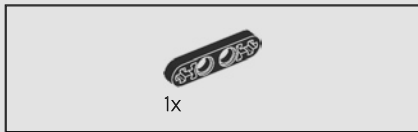
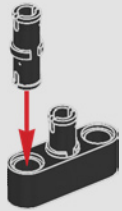

467

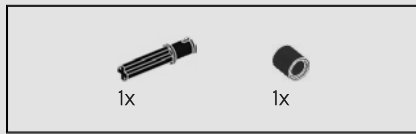
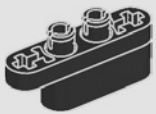

468

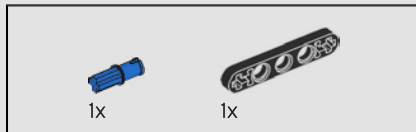
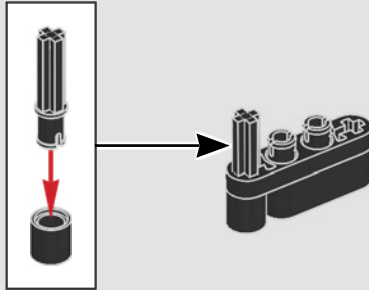

469

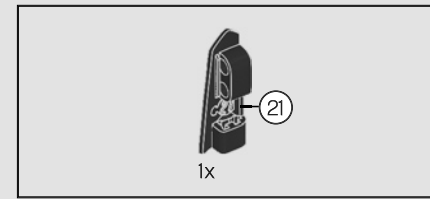
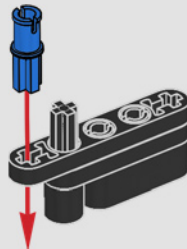

470

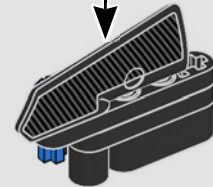
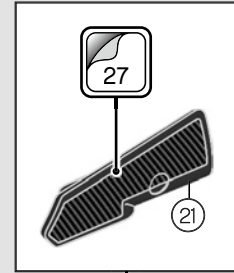

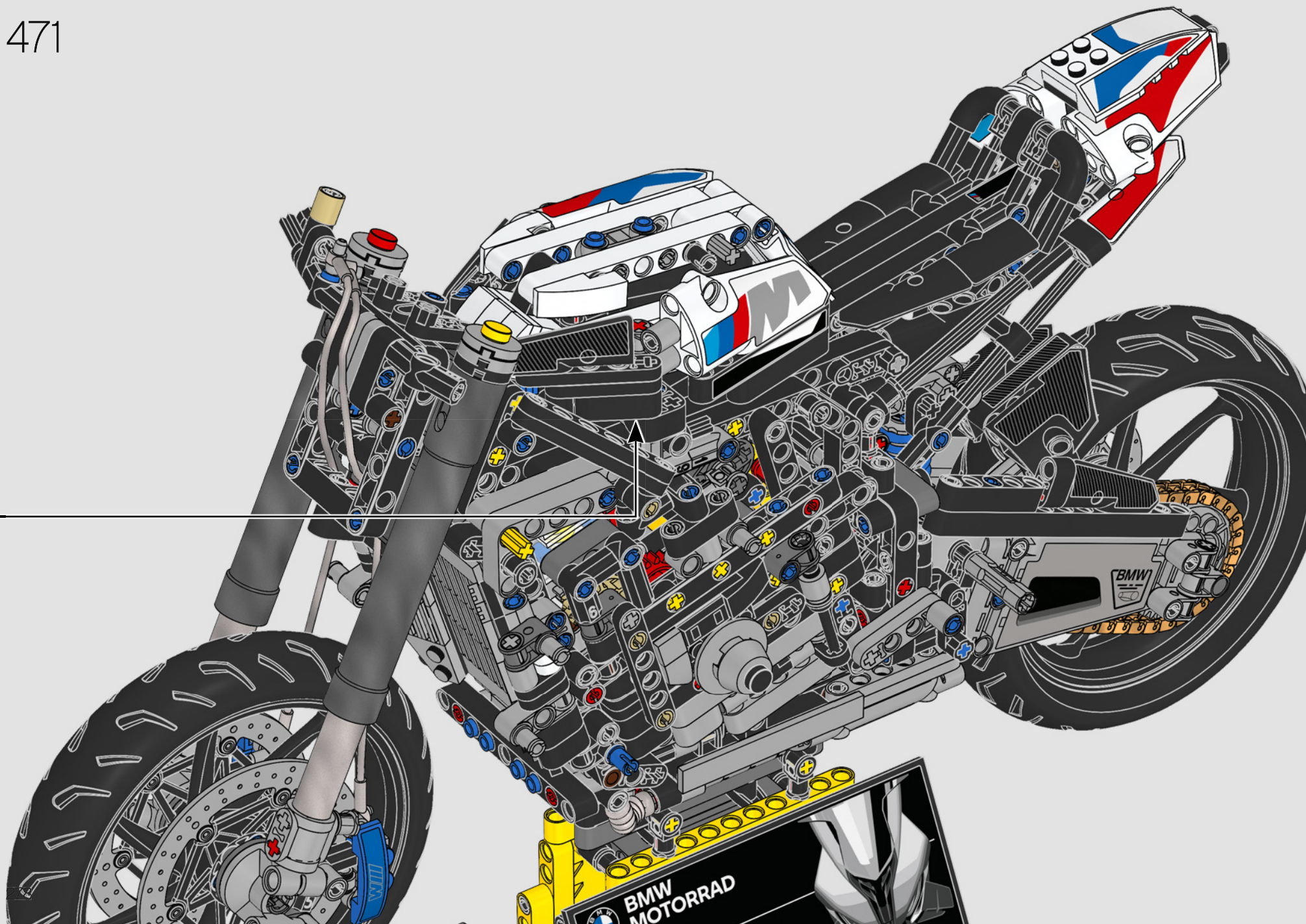

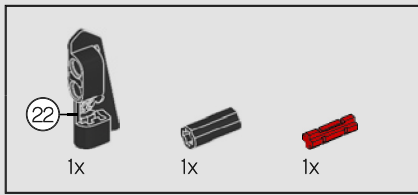

472

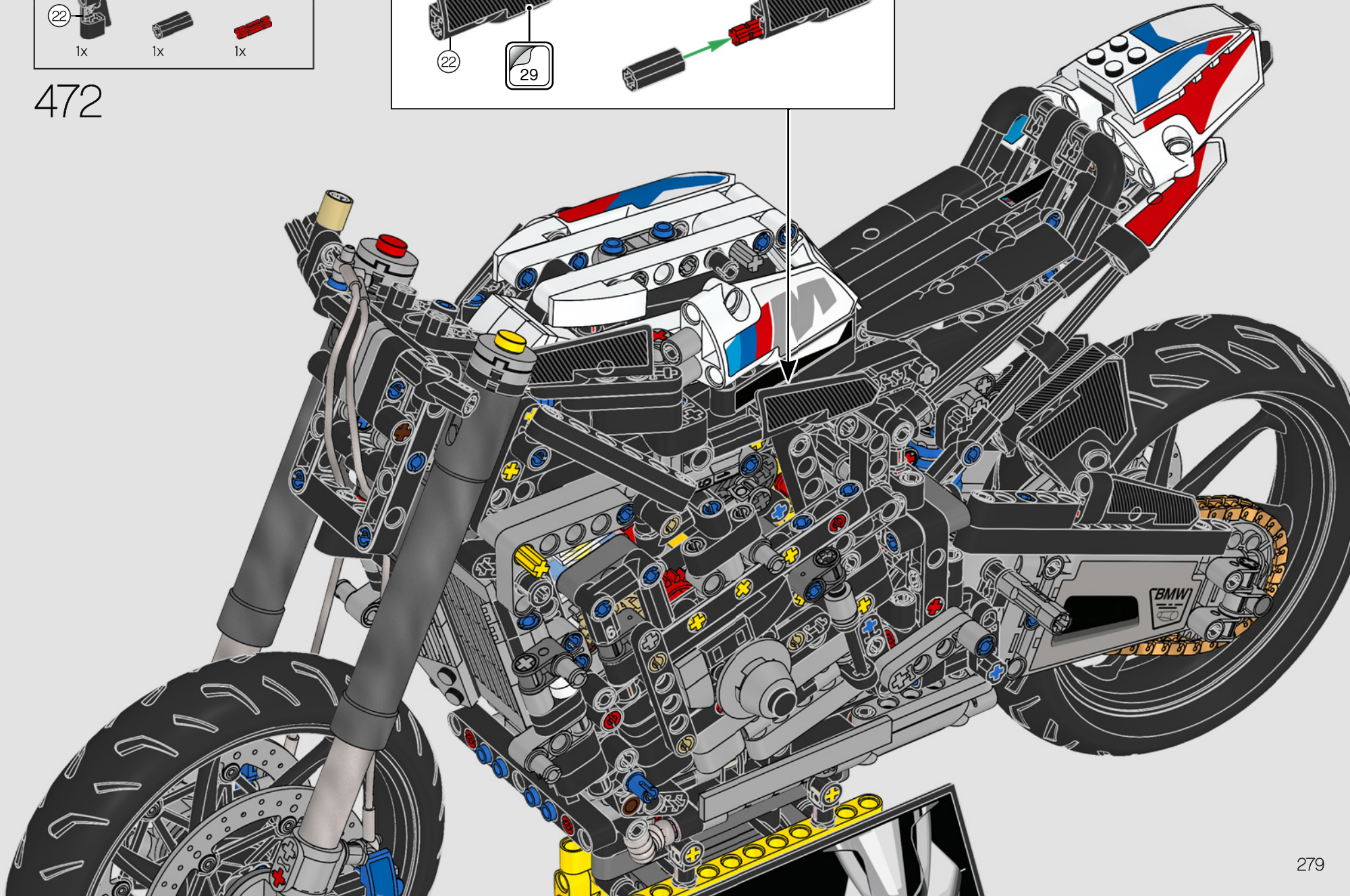
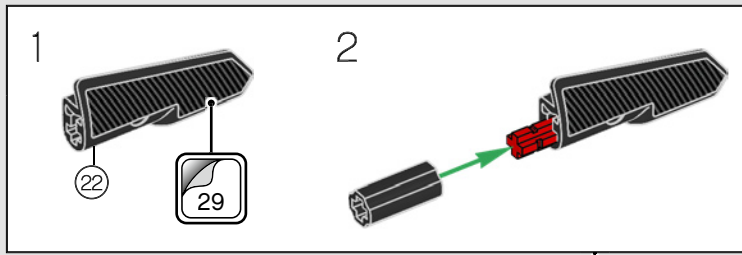

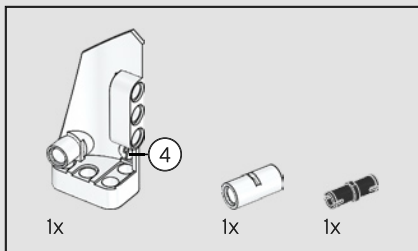

473

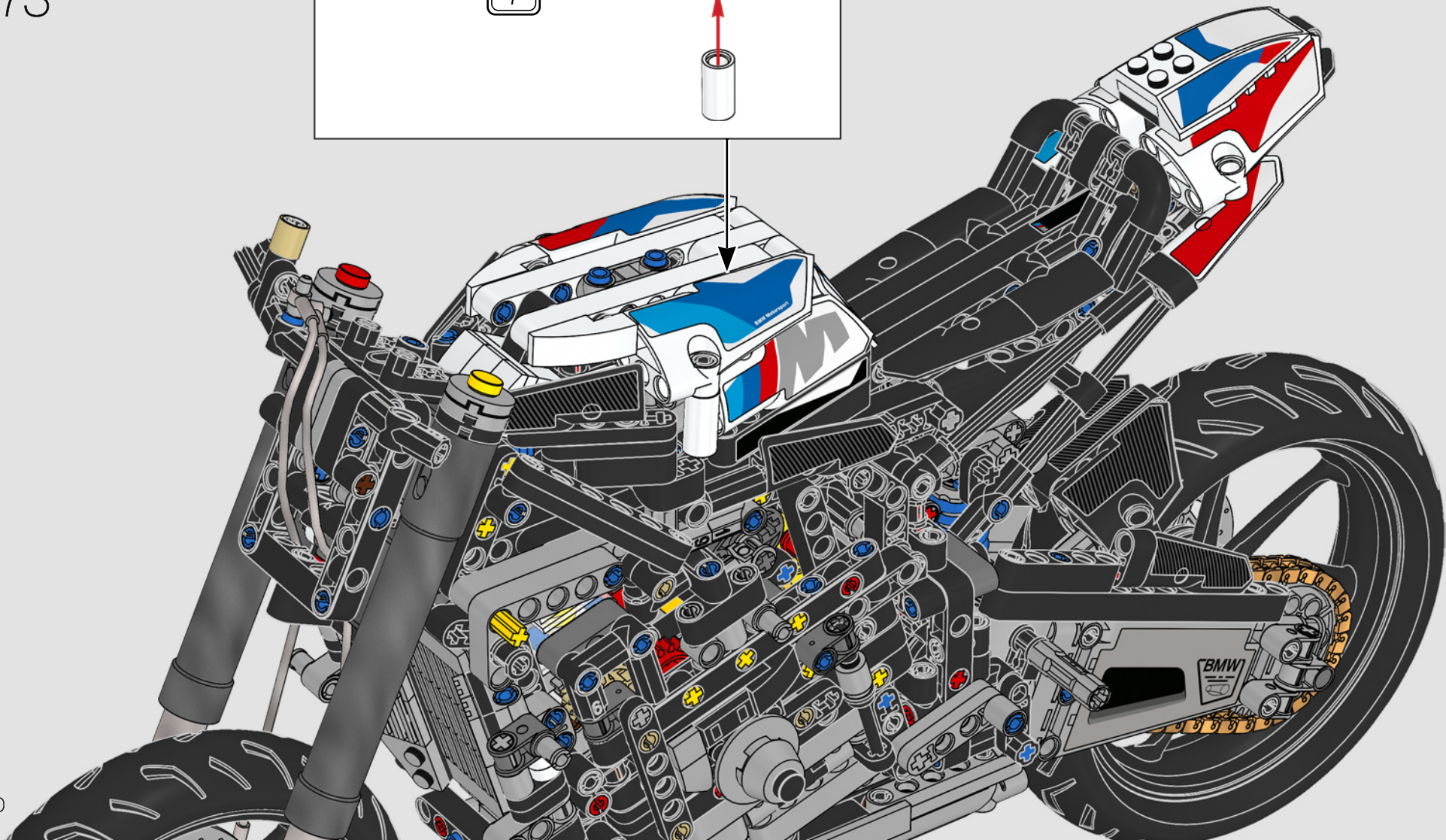
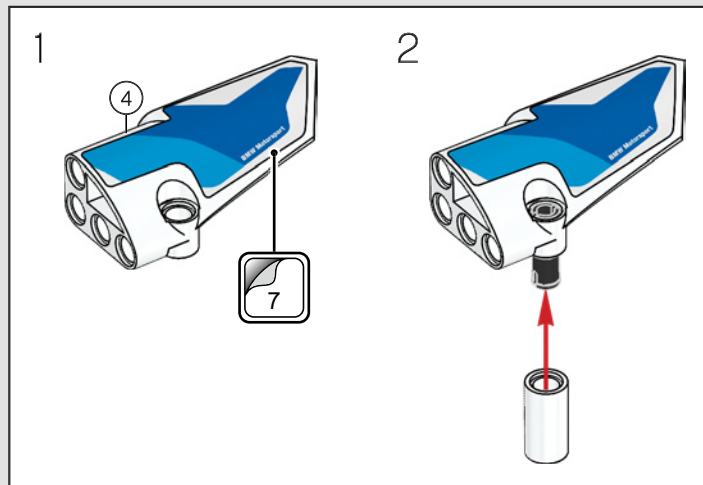

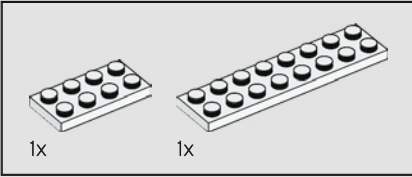
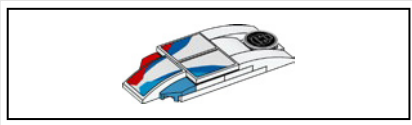

474

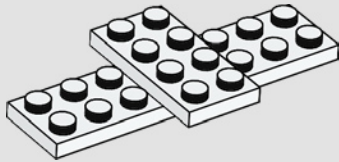

475

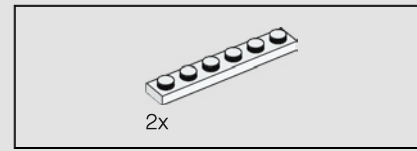
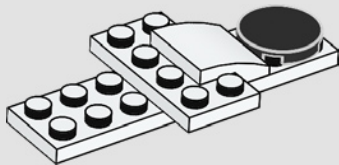

476

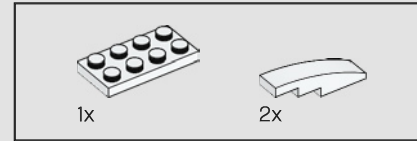
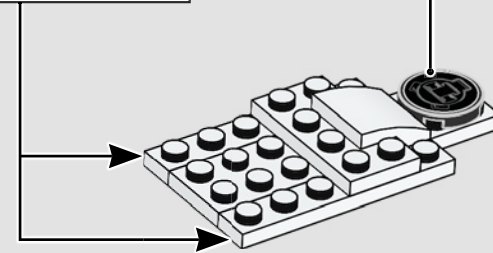
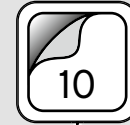
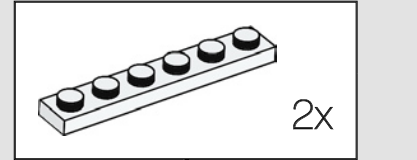

477

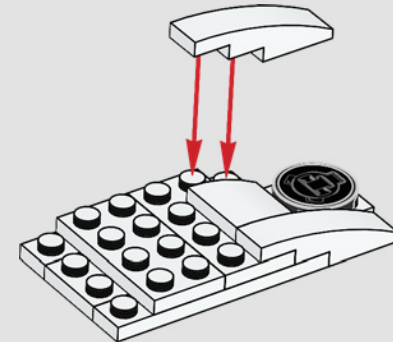

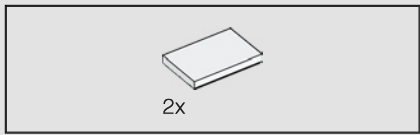

478

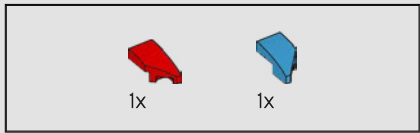
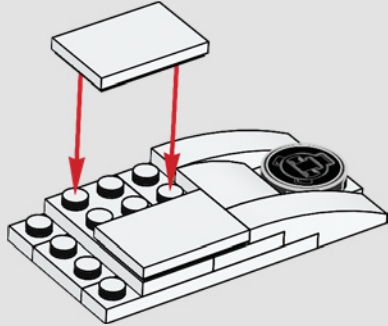

479

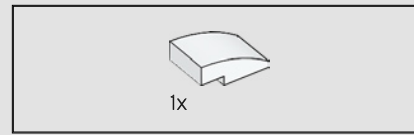
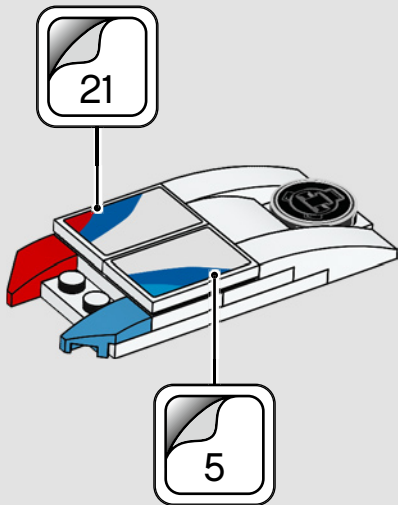

480

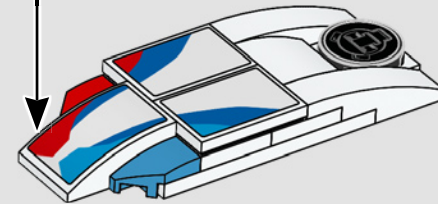
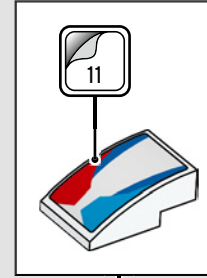

481

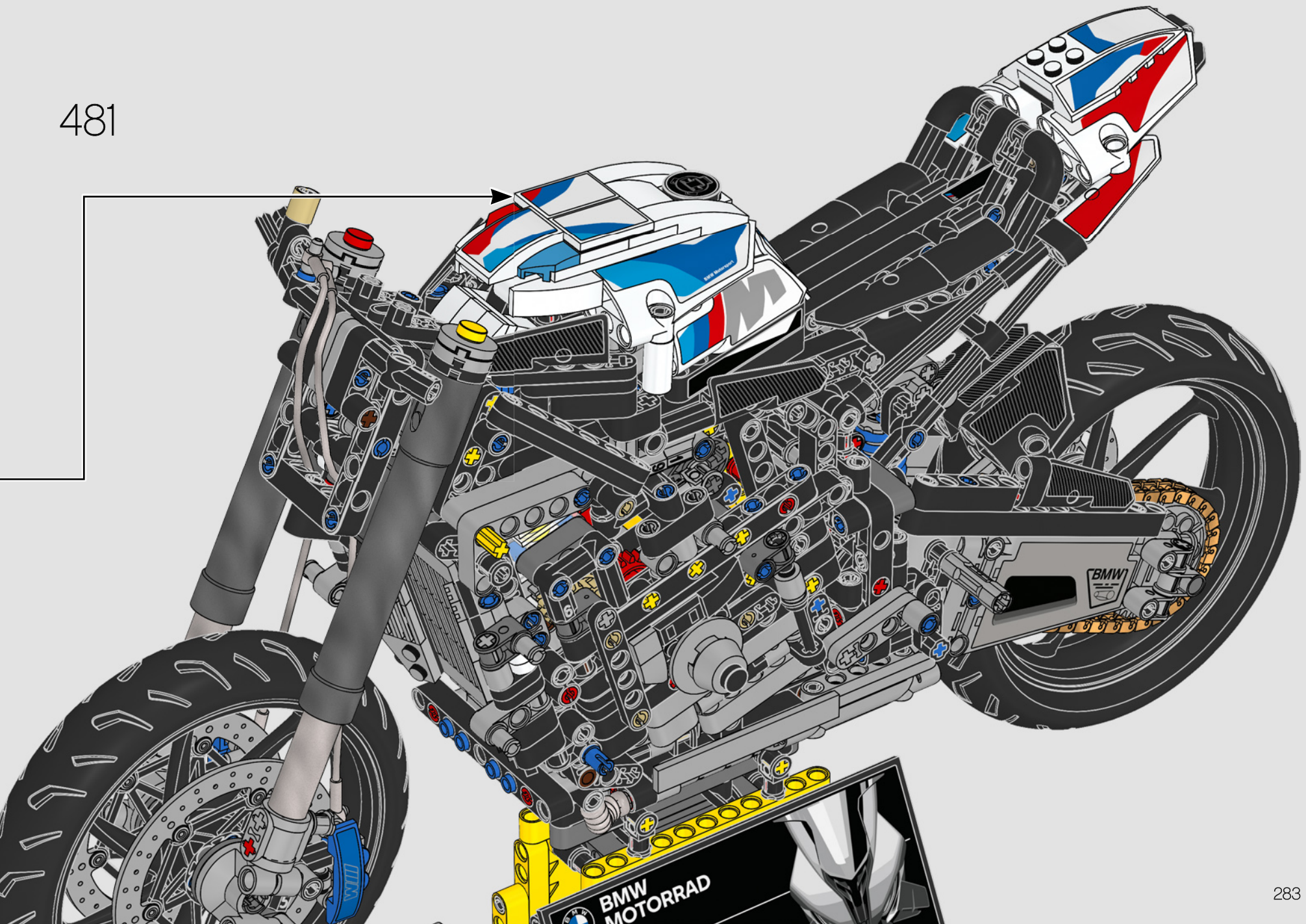

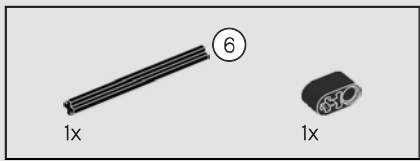

482

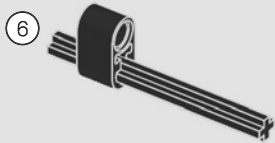

483

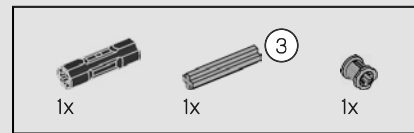
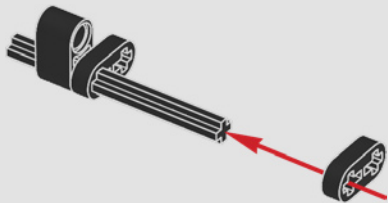

484

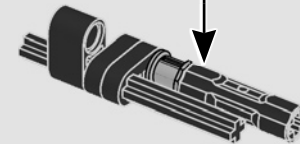
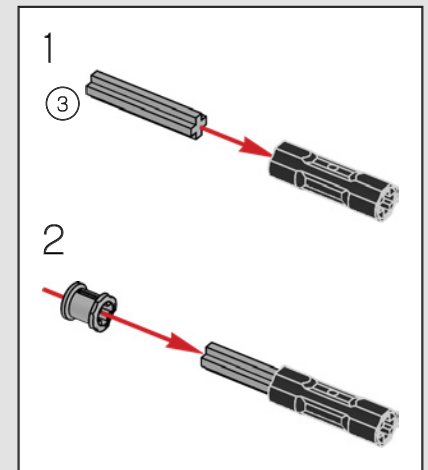

485

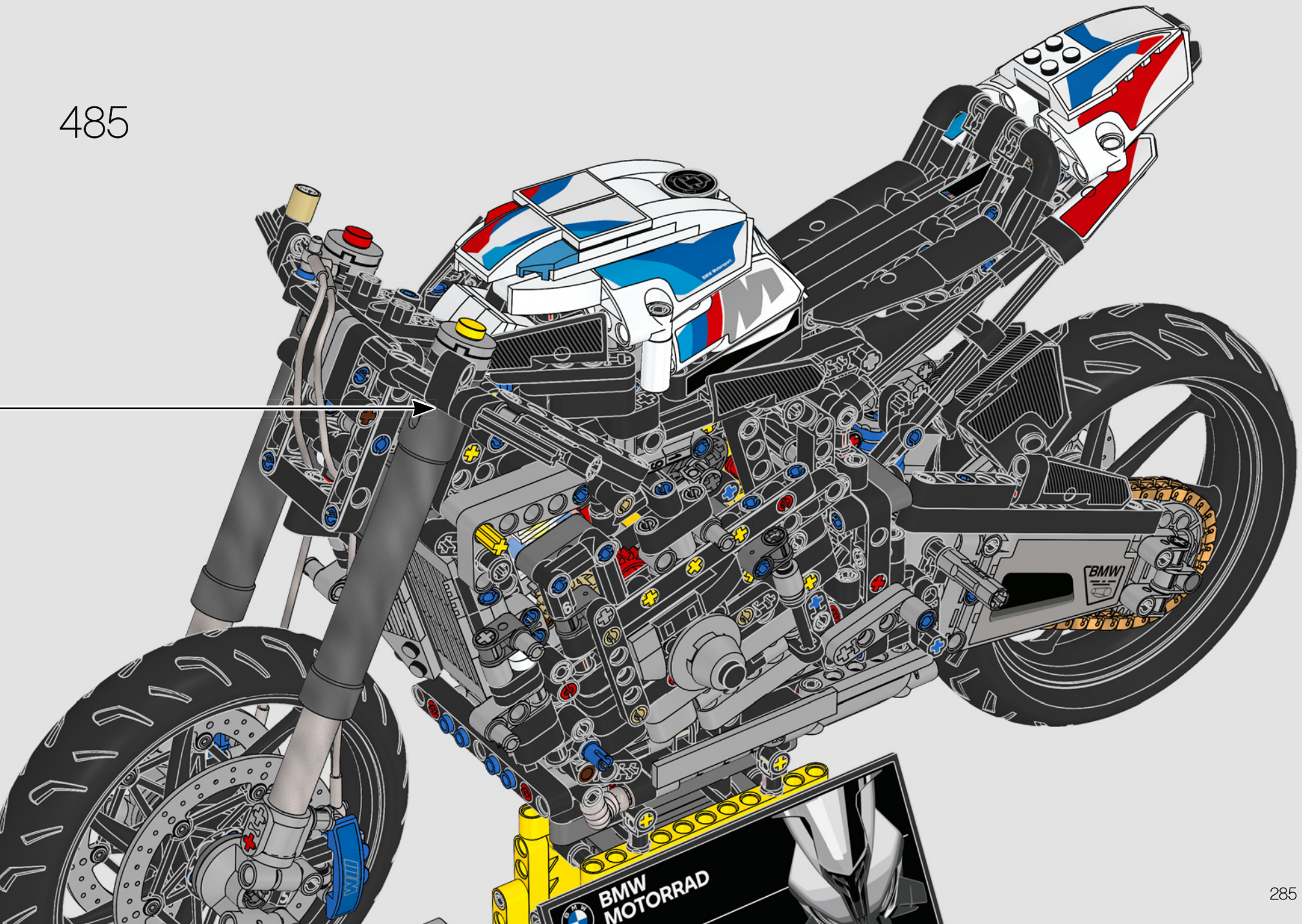

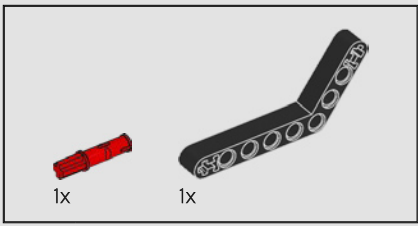

486

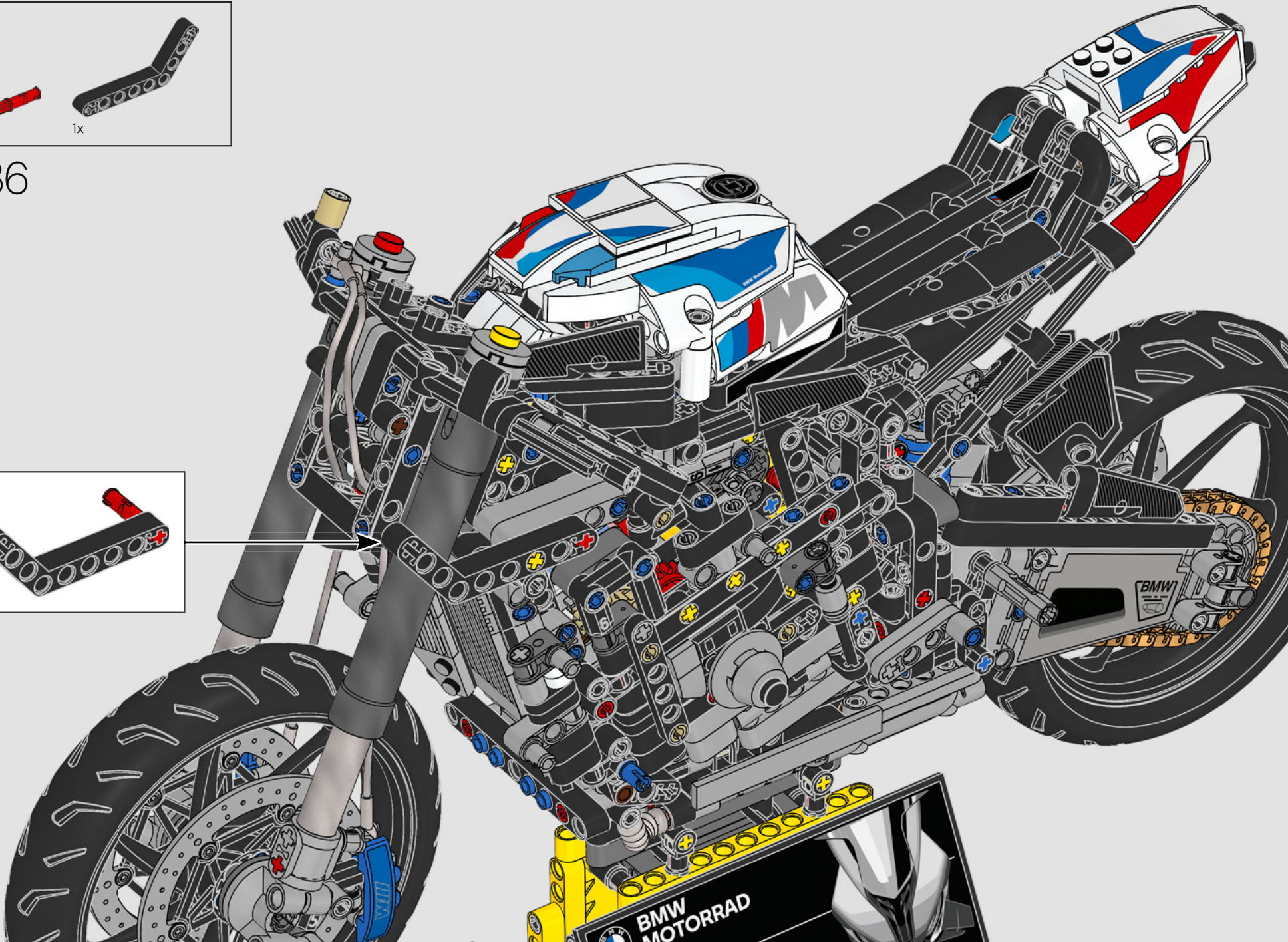
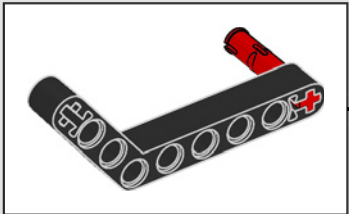

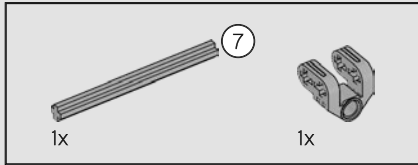
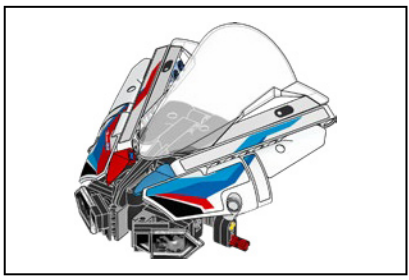

487

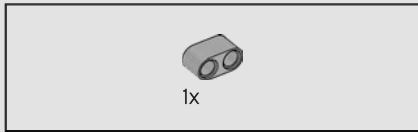
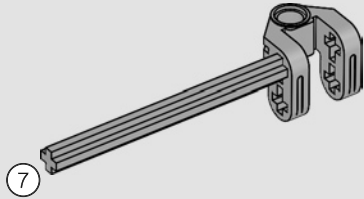

488

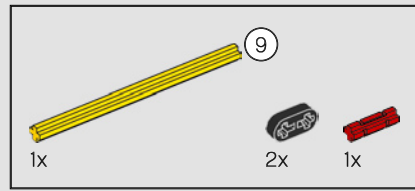
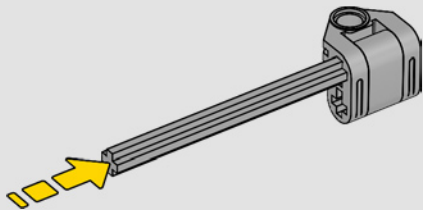

489

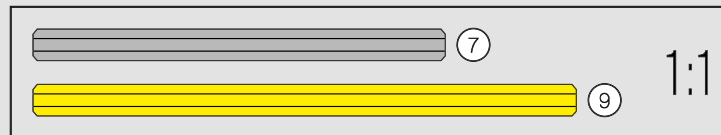
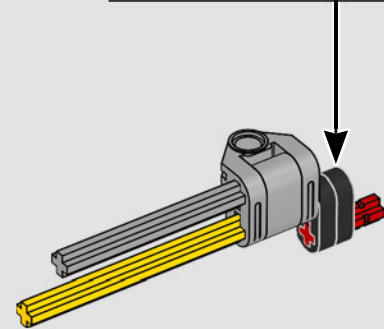
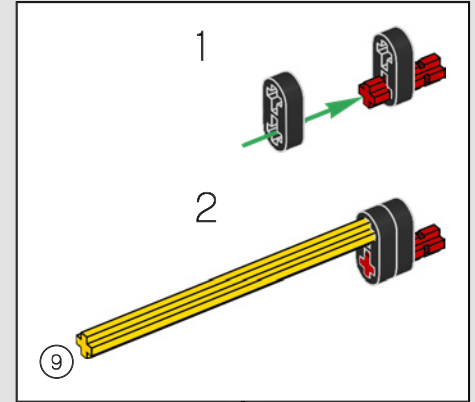

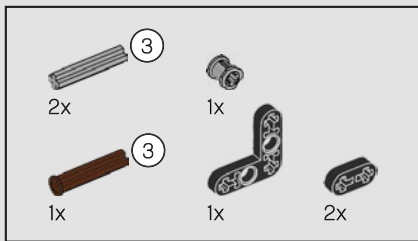

490

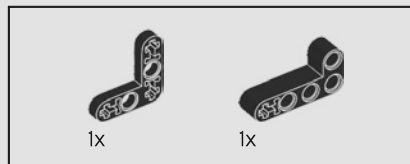
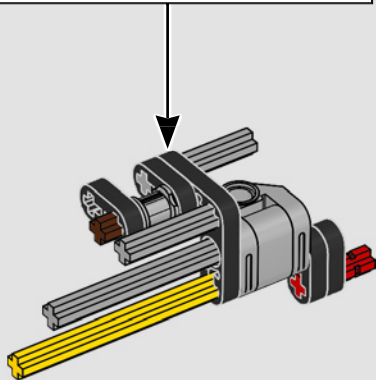
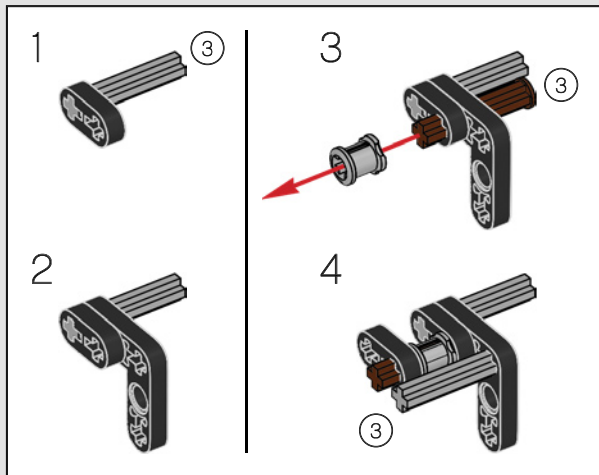

491

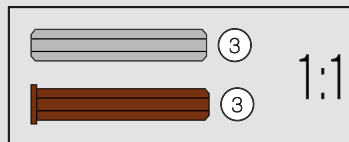
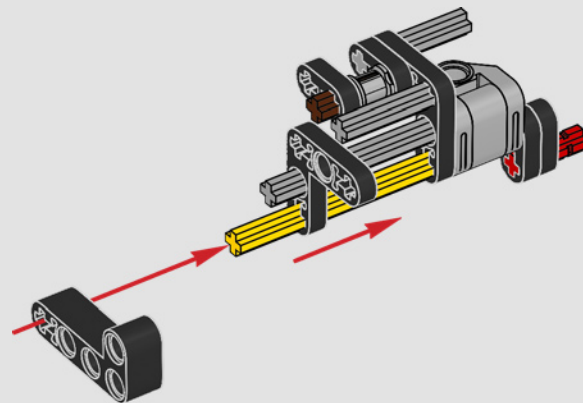

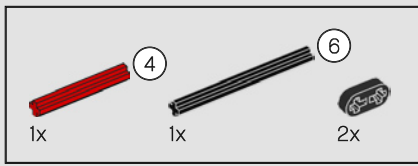

492

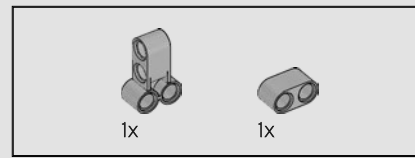
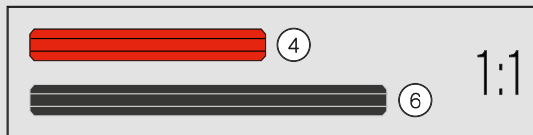
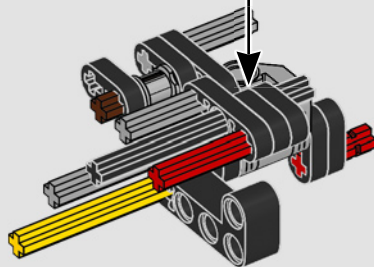
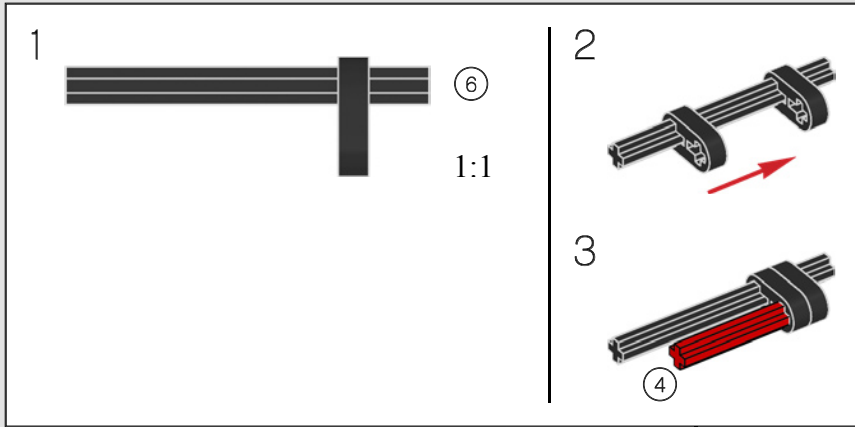

493

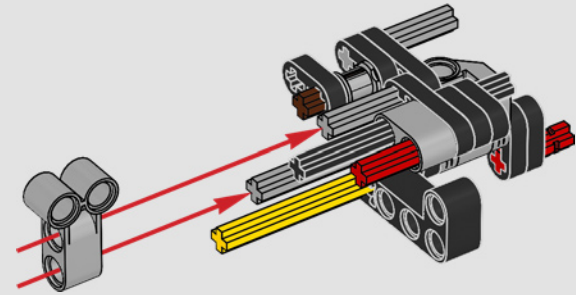

494

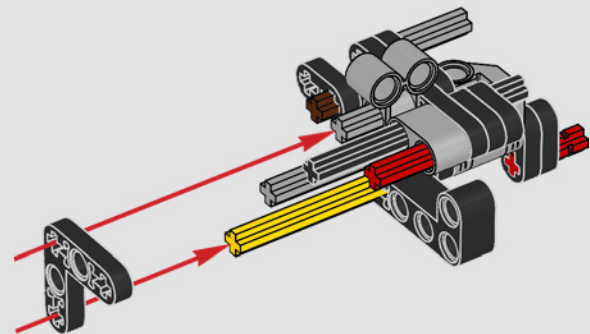

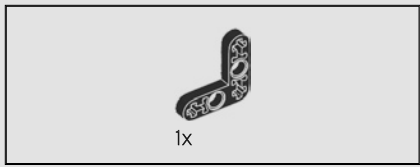

495

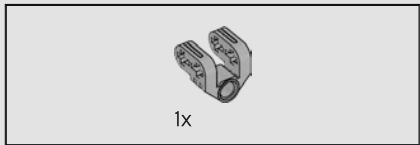
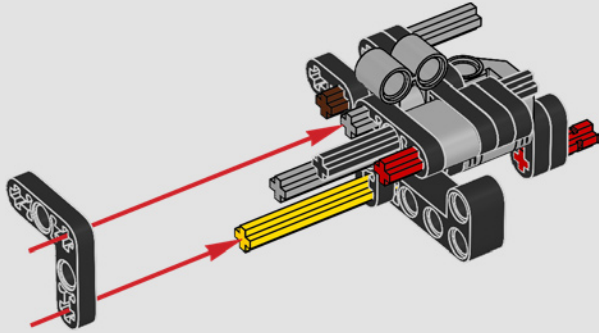

496

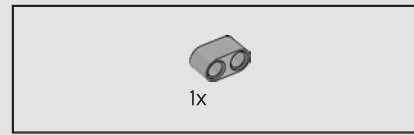
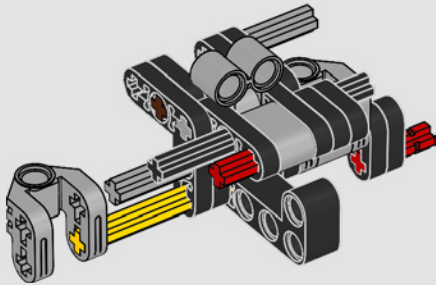

497

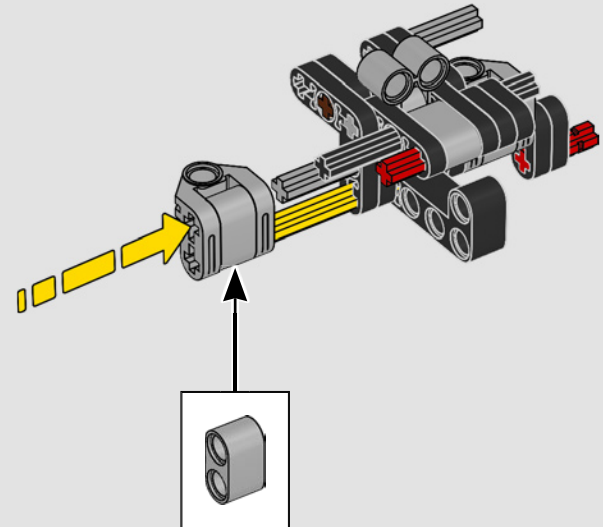

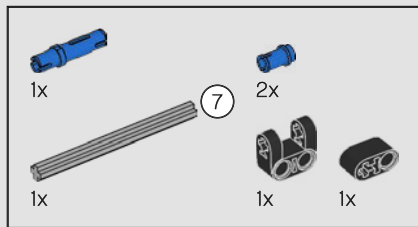

498

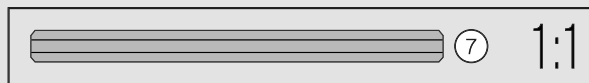
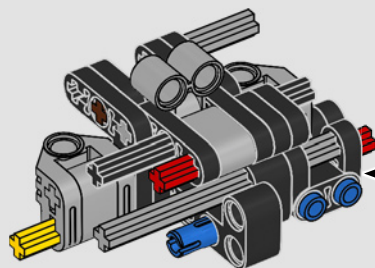
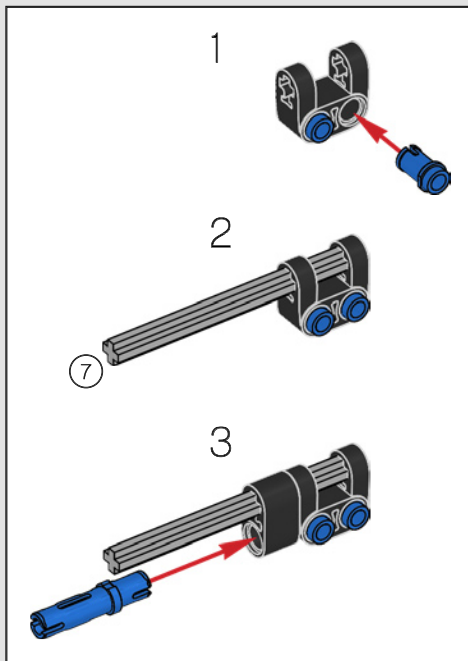

499

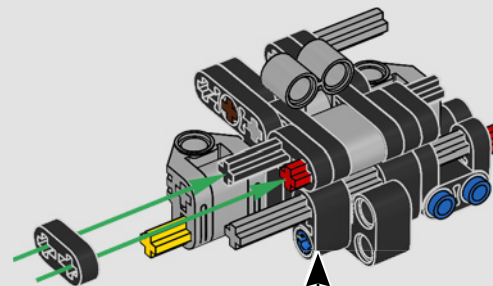

500

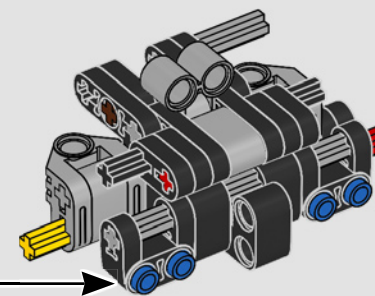
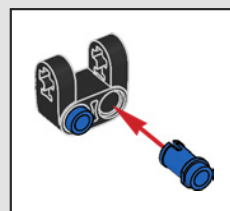

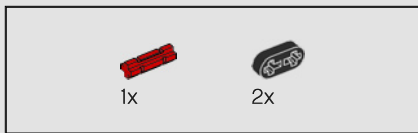

501

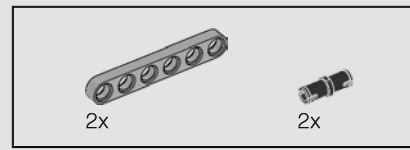
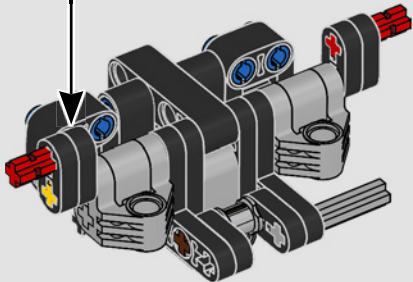
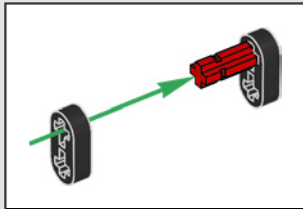

502

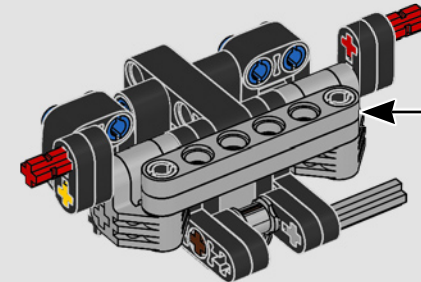
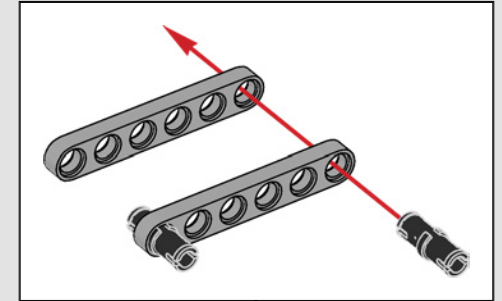

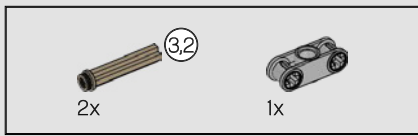

503

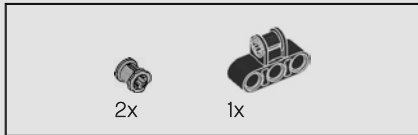
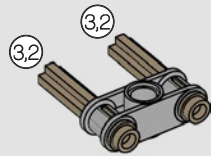
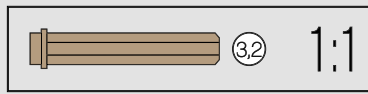

504

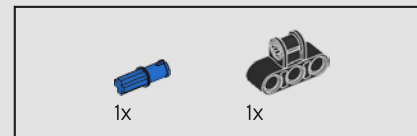
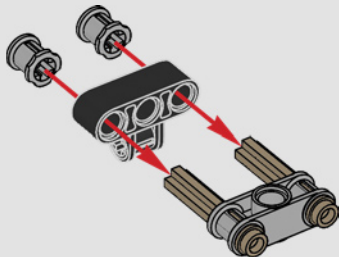

505

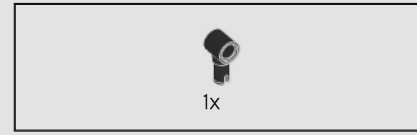
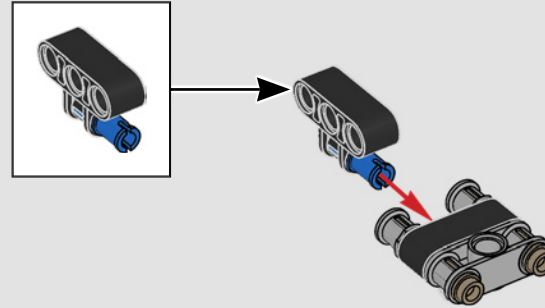

506

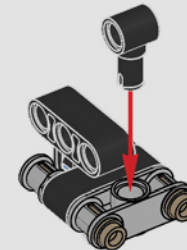

507

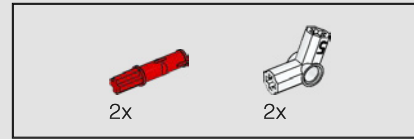
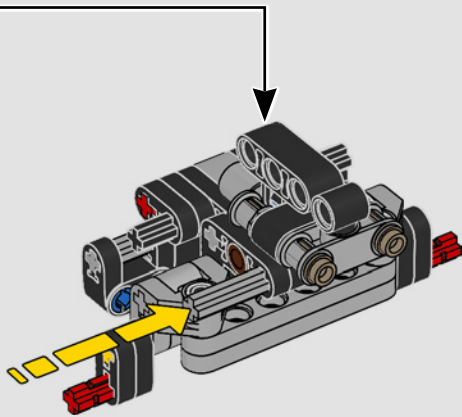

508

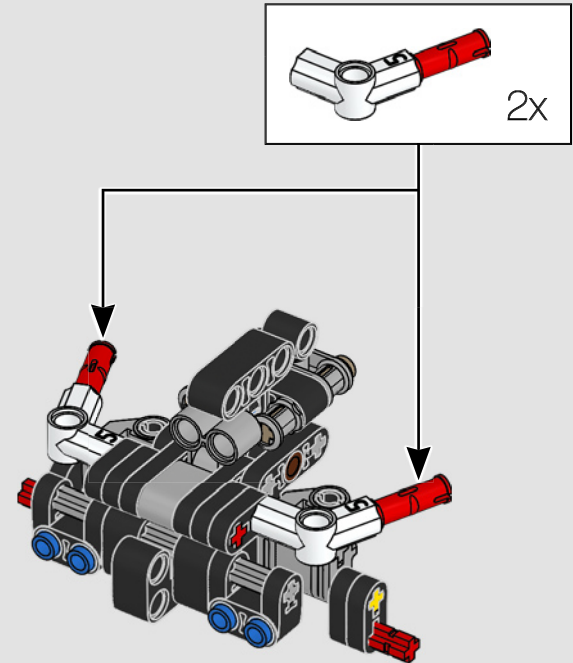
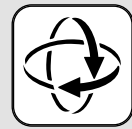

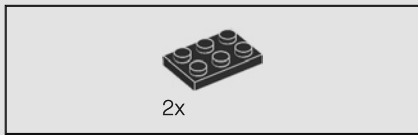

509

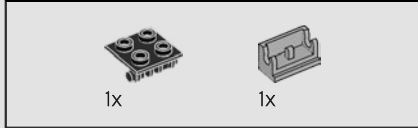
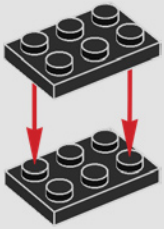

510

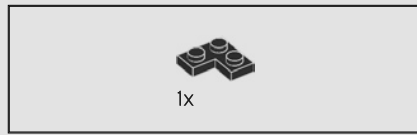
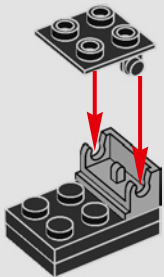

511

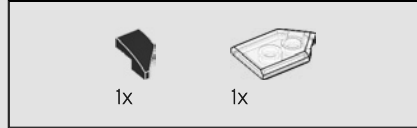
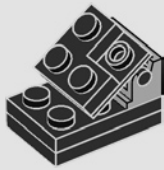

512

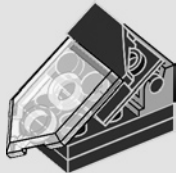

513

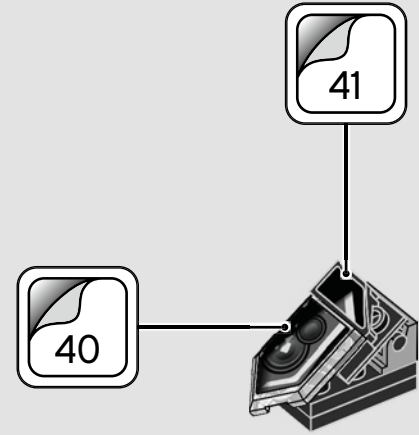

514

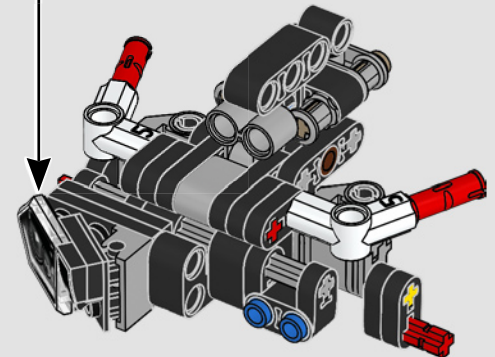

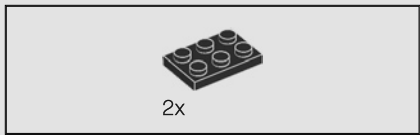

515

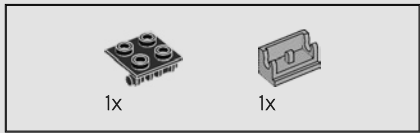
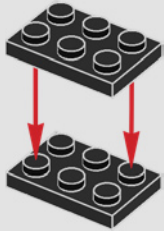

516

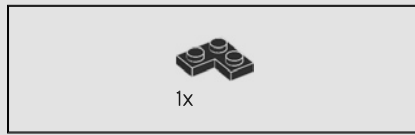
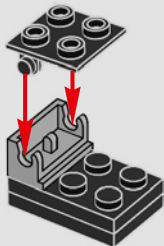

517

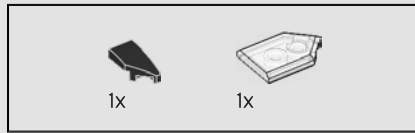
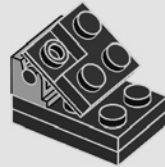

518

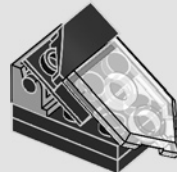

519

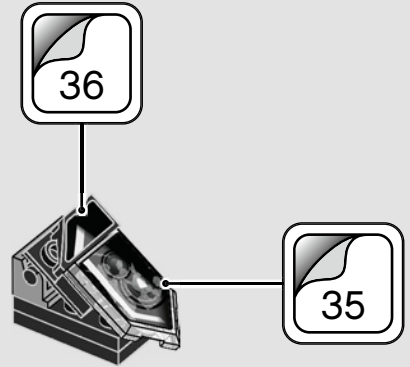

520

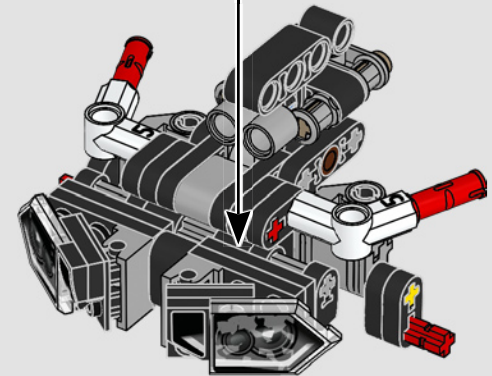

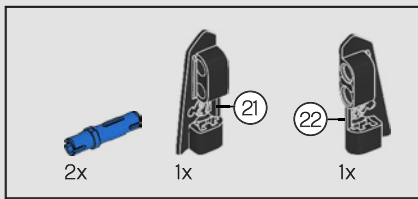

521

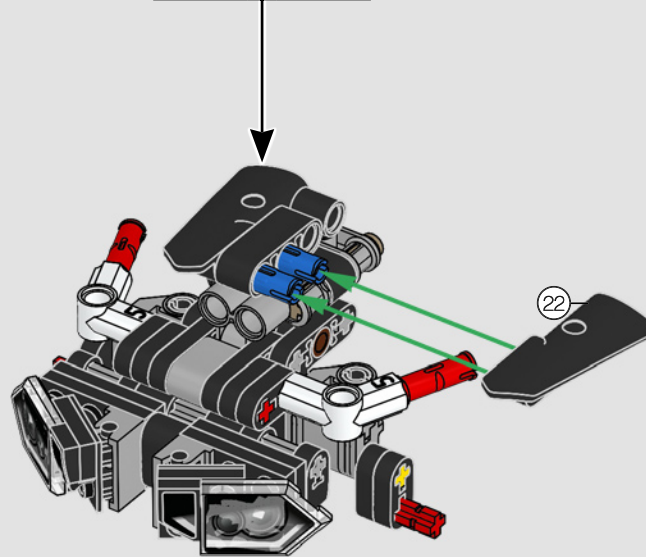
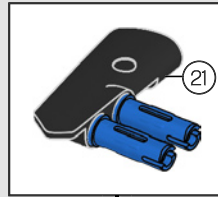

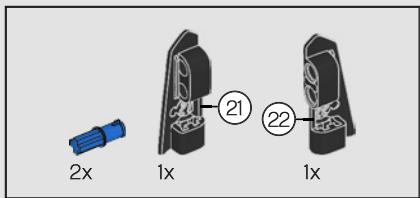

522

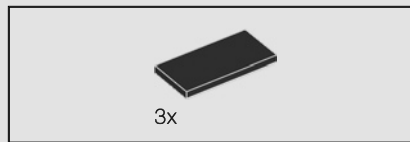
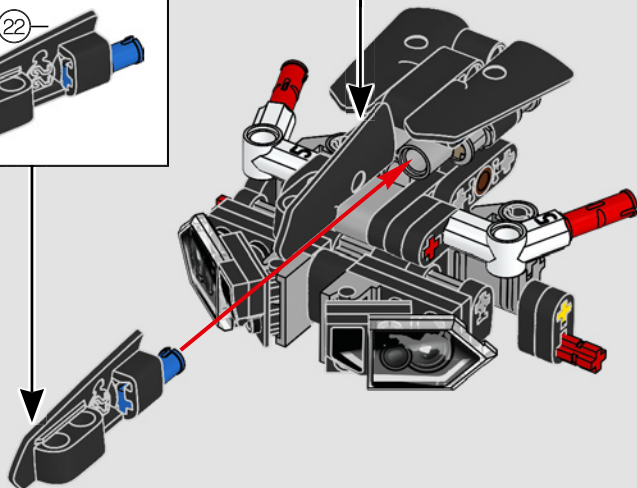
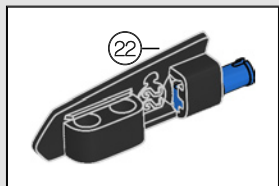
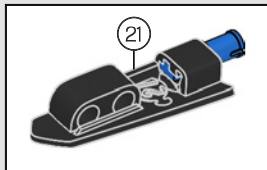

523

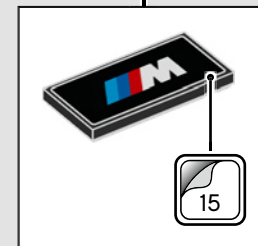
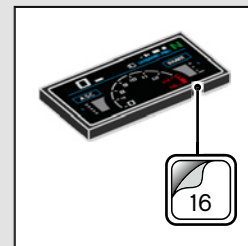
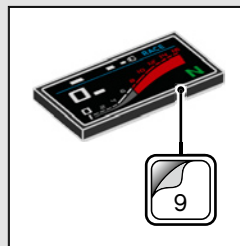
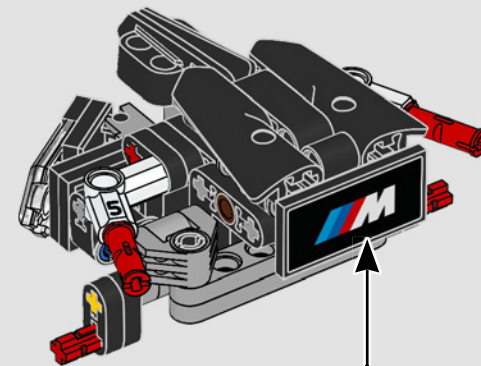
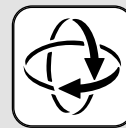

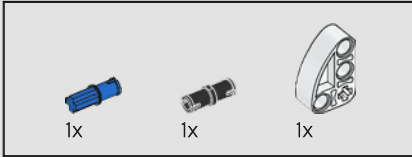
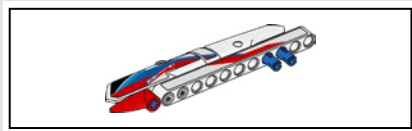

524

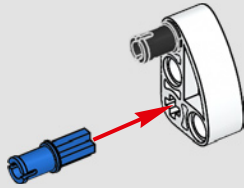

525

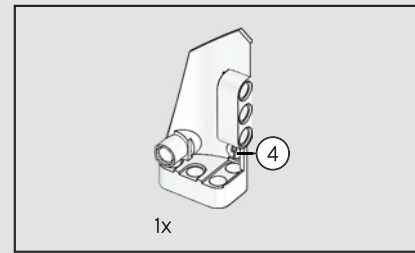
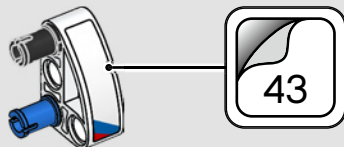

526

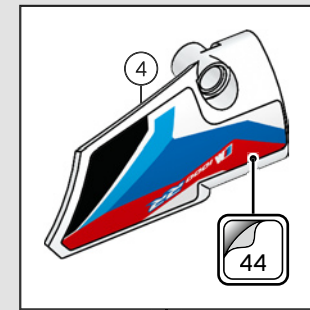

527

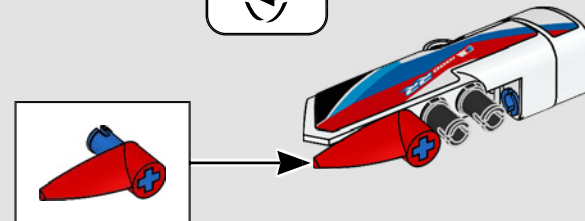
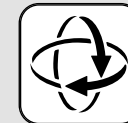

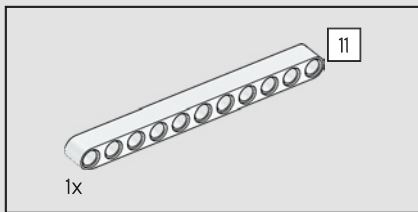

528

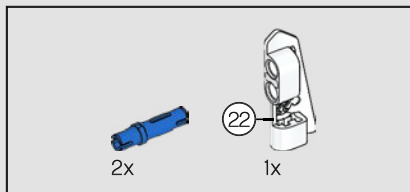
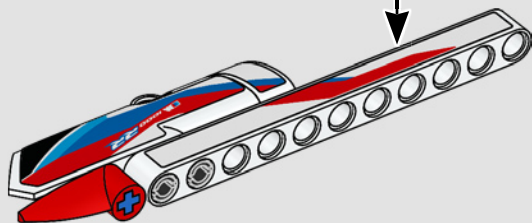
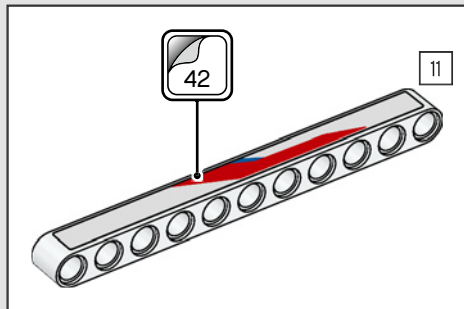

529

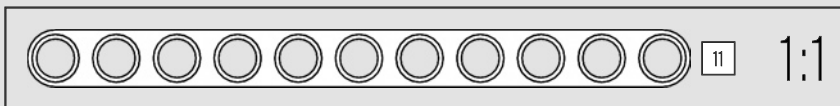
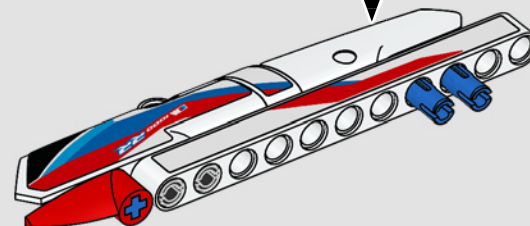
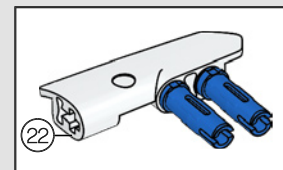

530

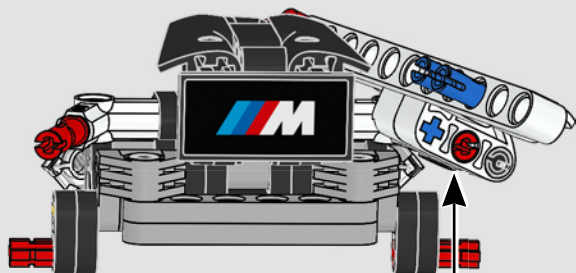

531

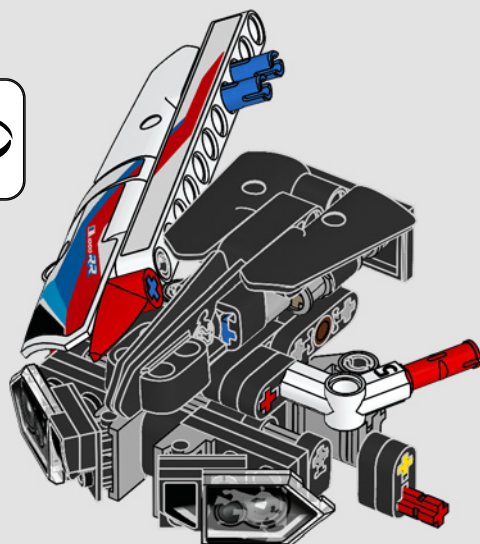

532

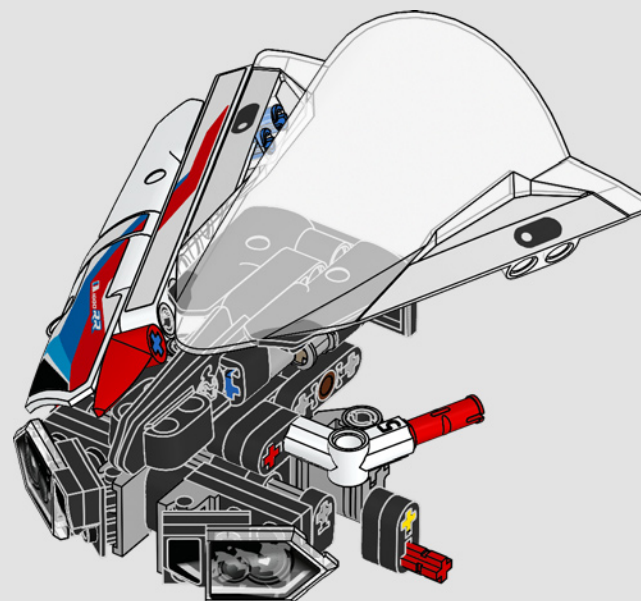
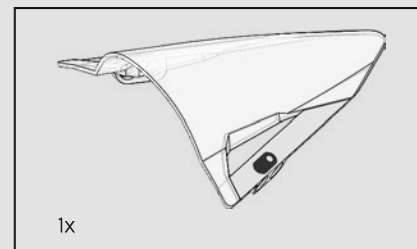

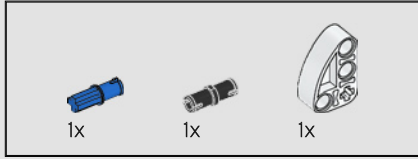
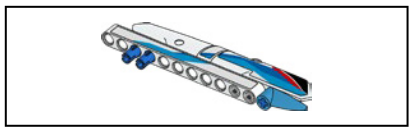

533

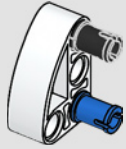

534

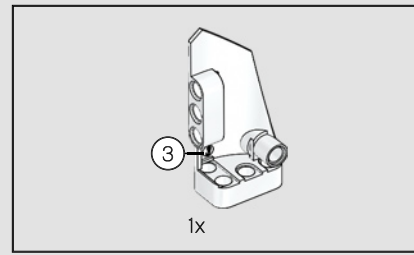
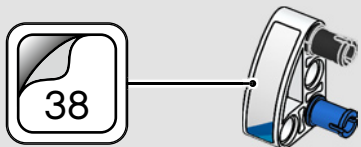

535

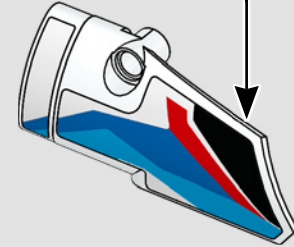
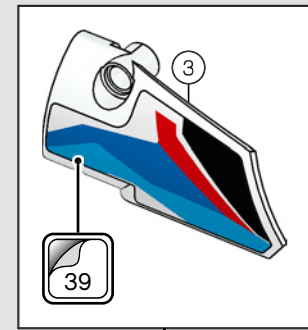

536

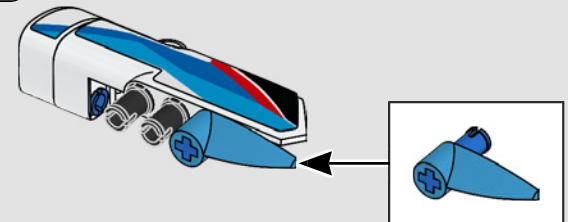
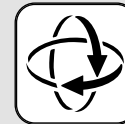

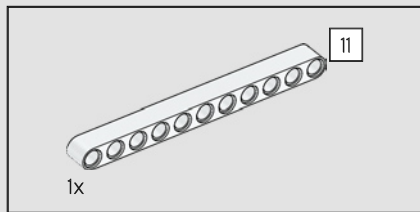

537

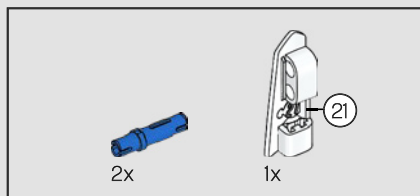
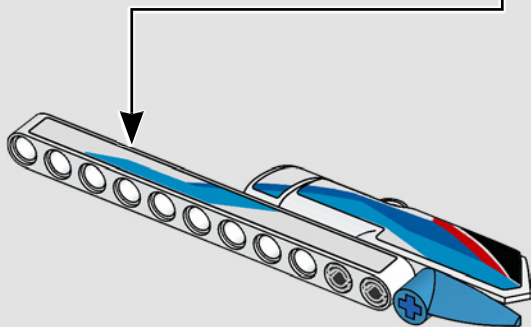
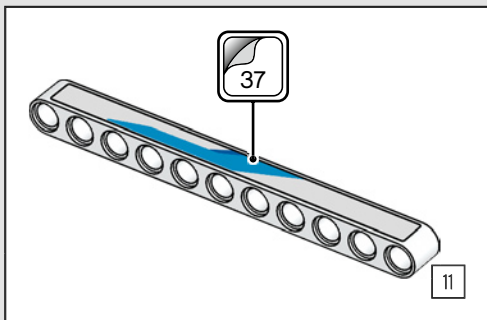

538

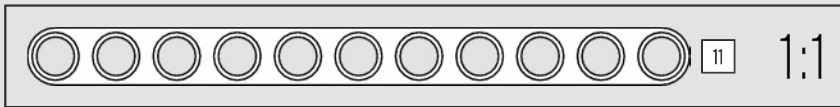
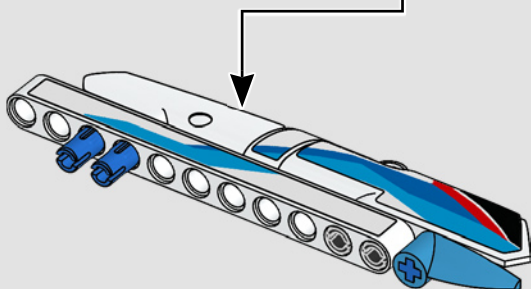
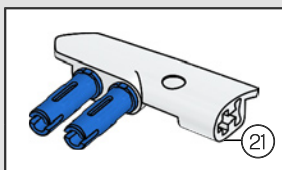

539

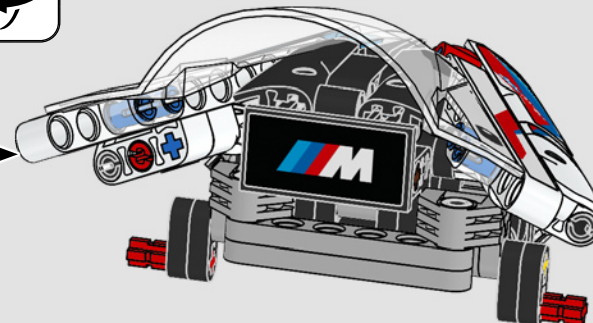

540

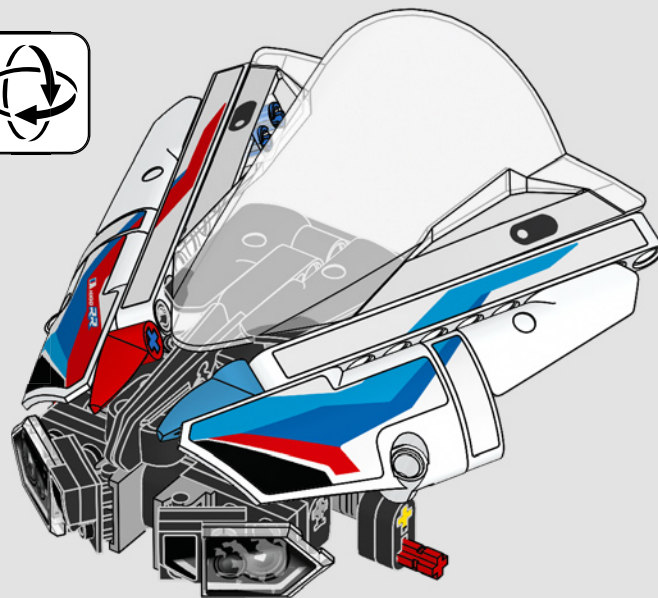

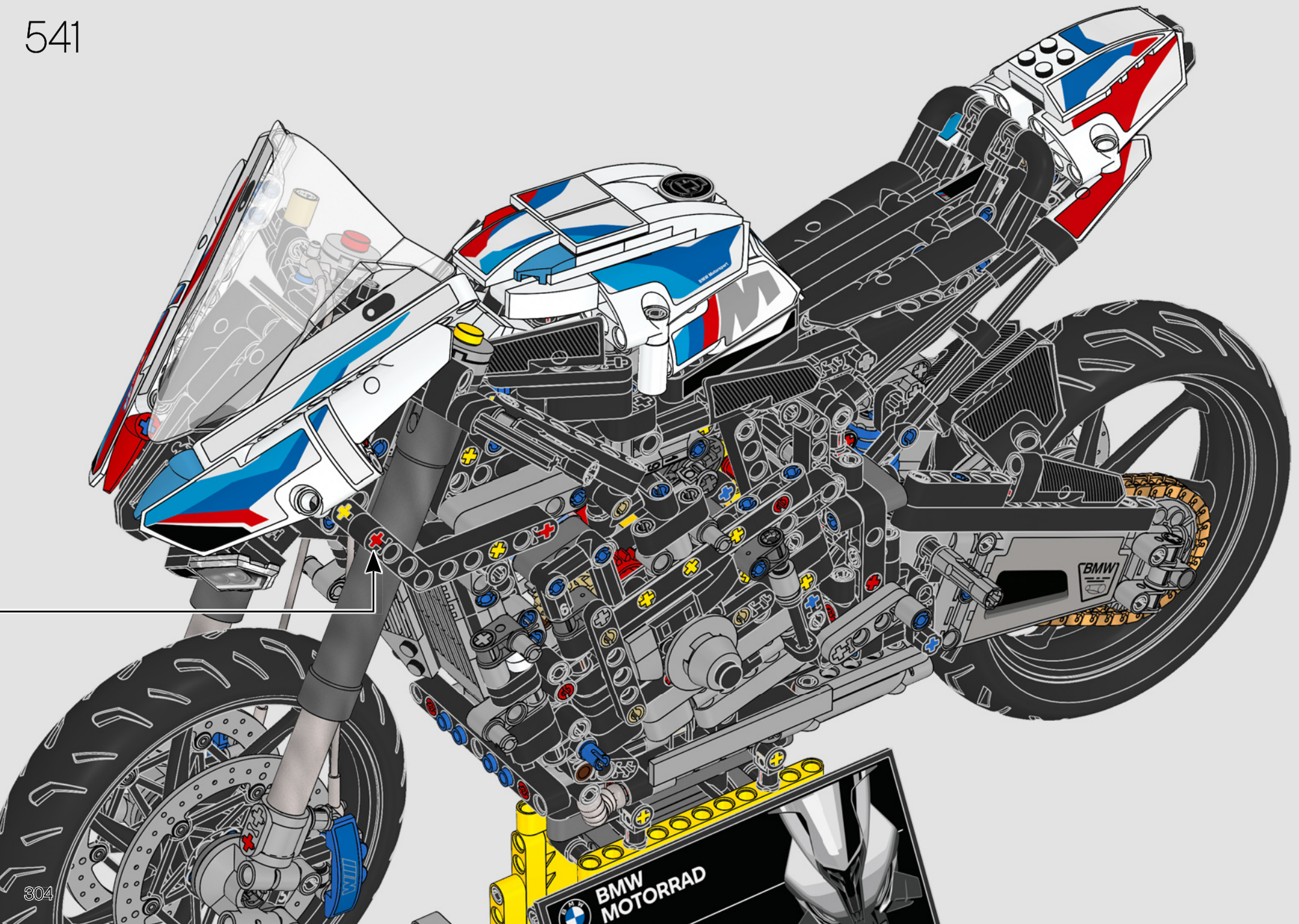

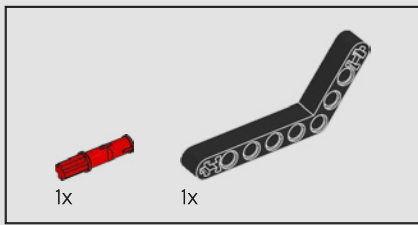

542

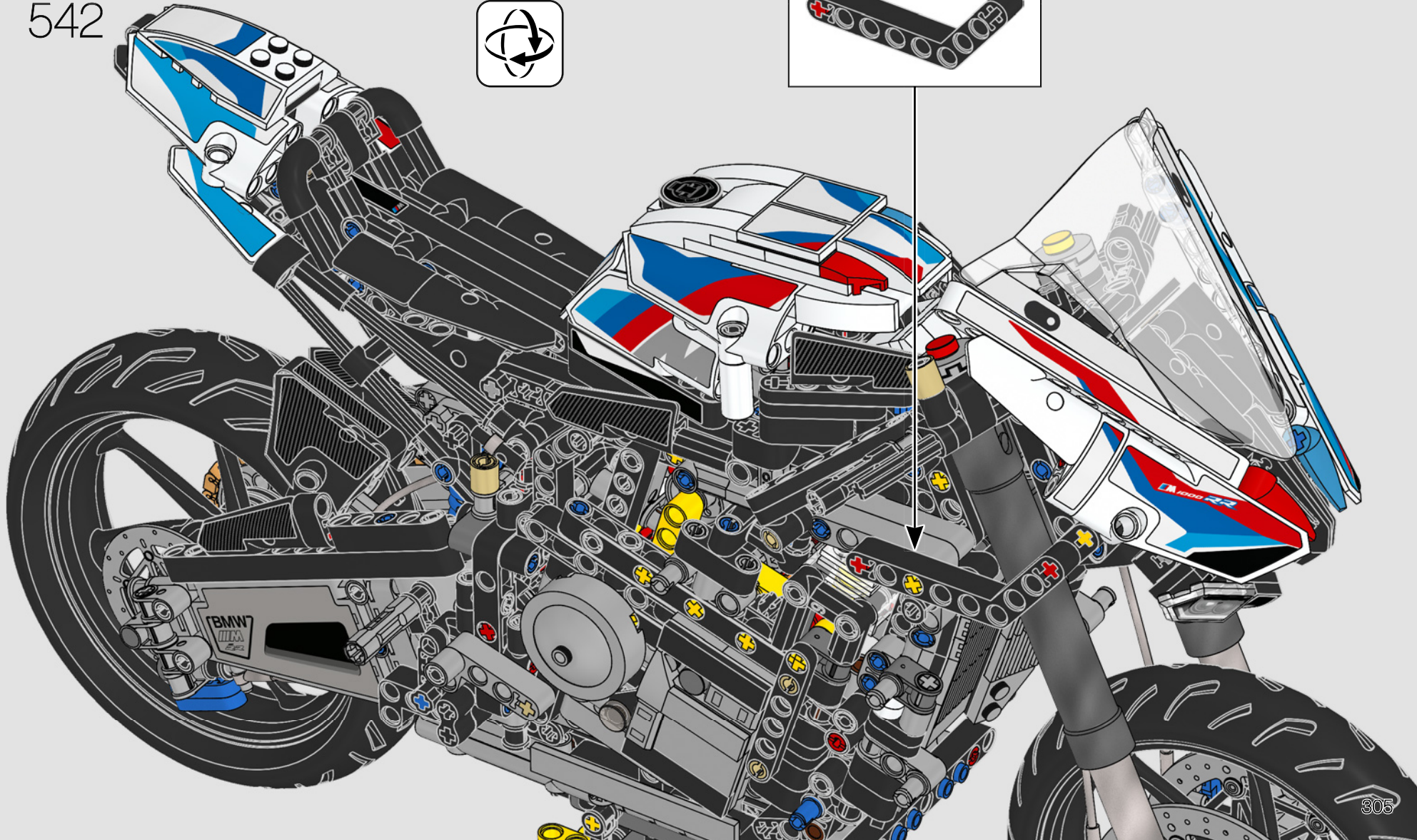
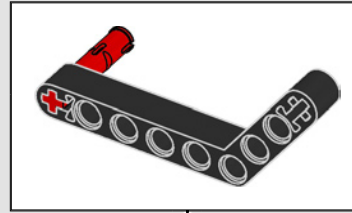

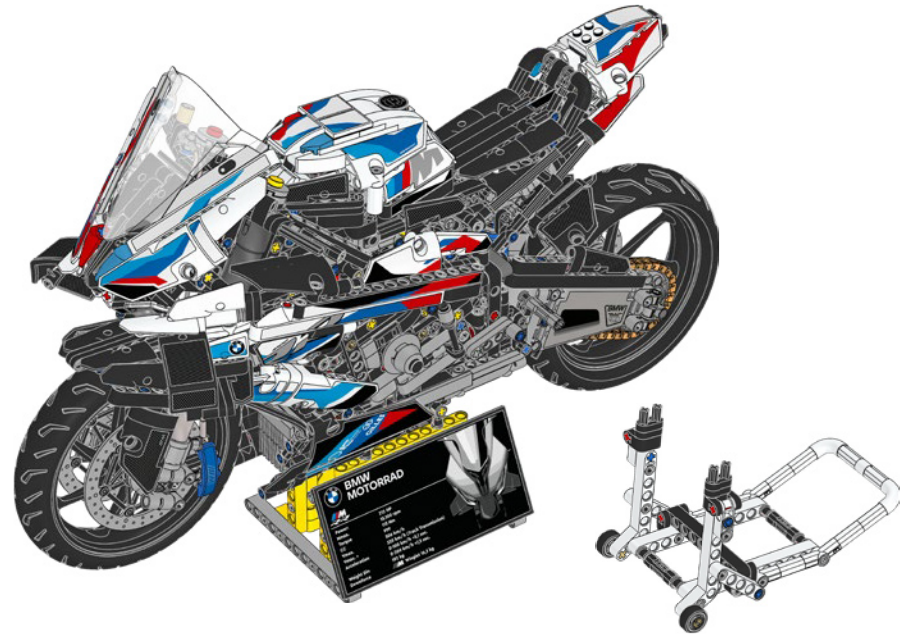
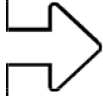

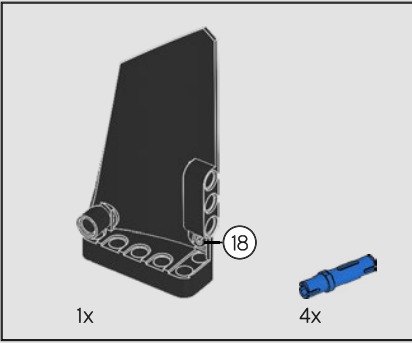
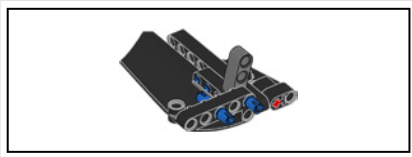

543

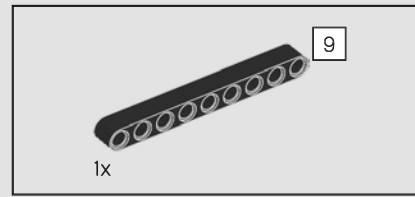
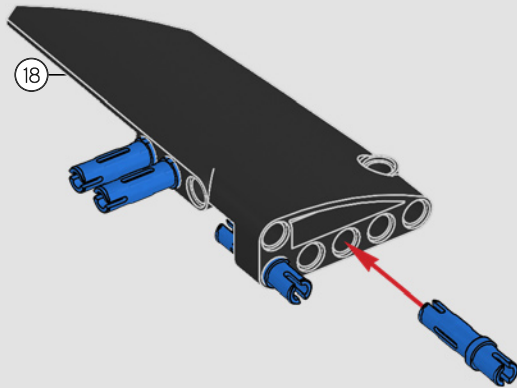

544

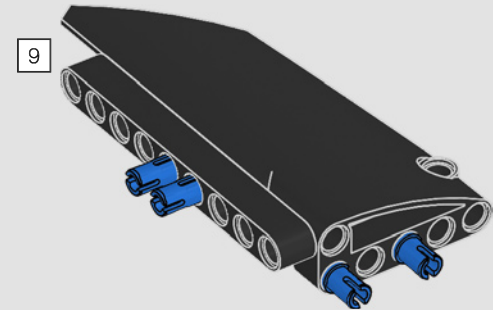

545

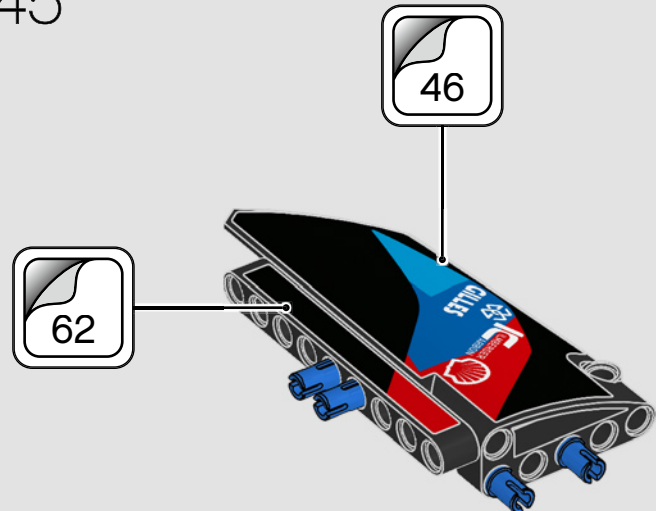

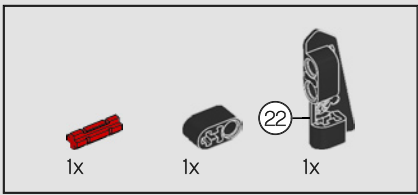

546

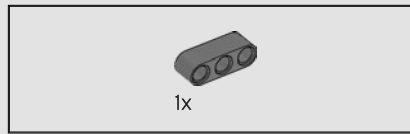
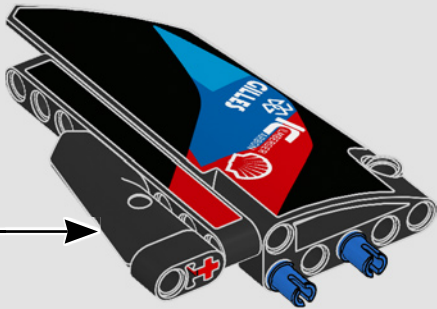
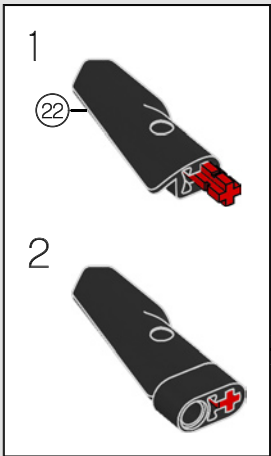

547

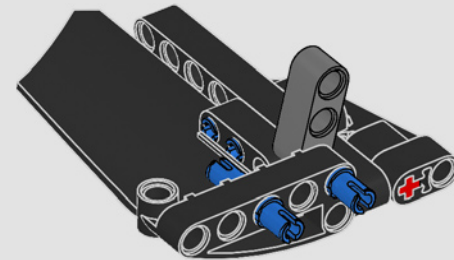
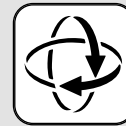

548

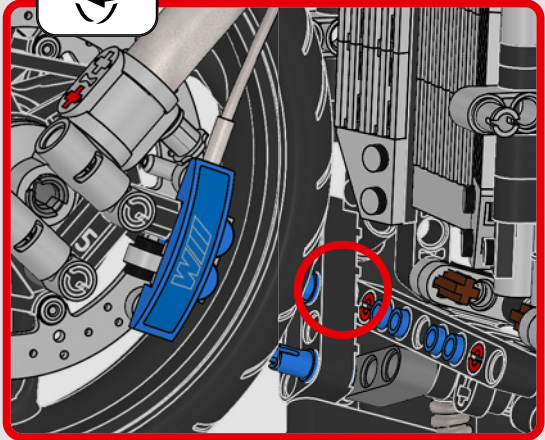
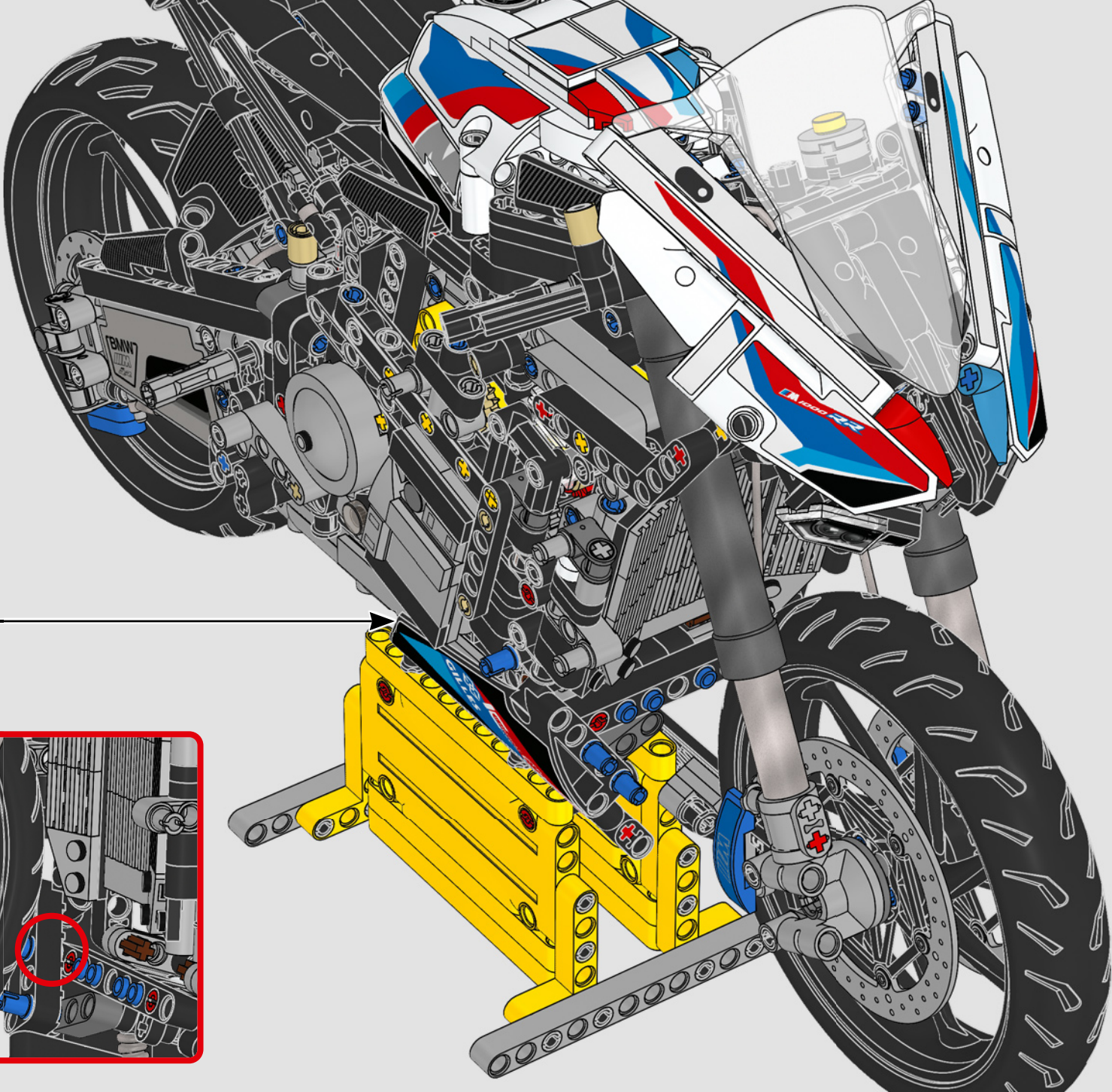

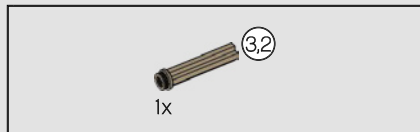

549

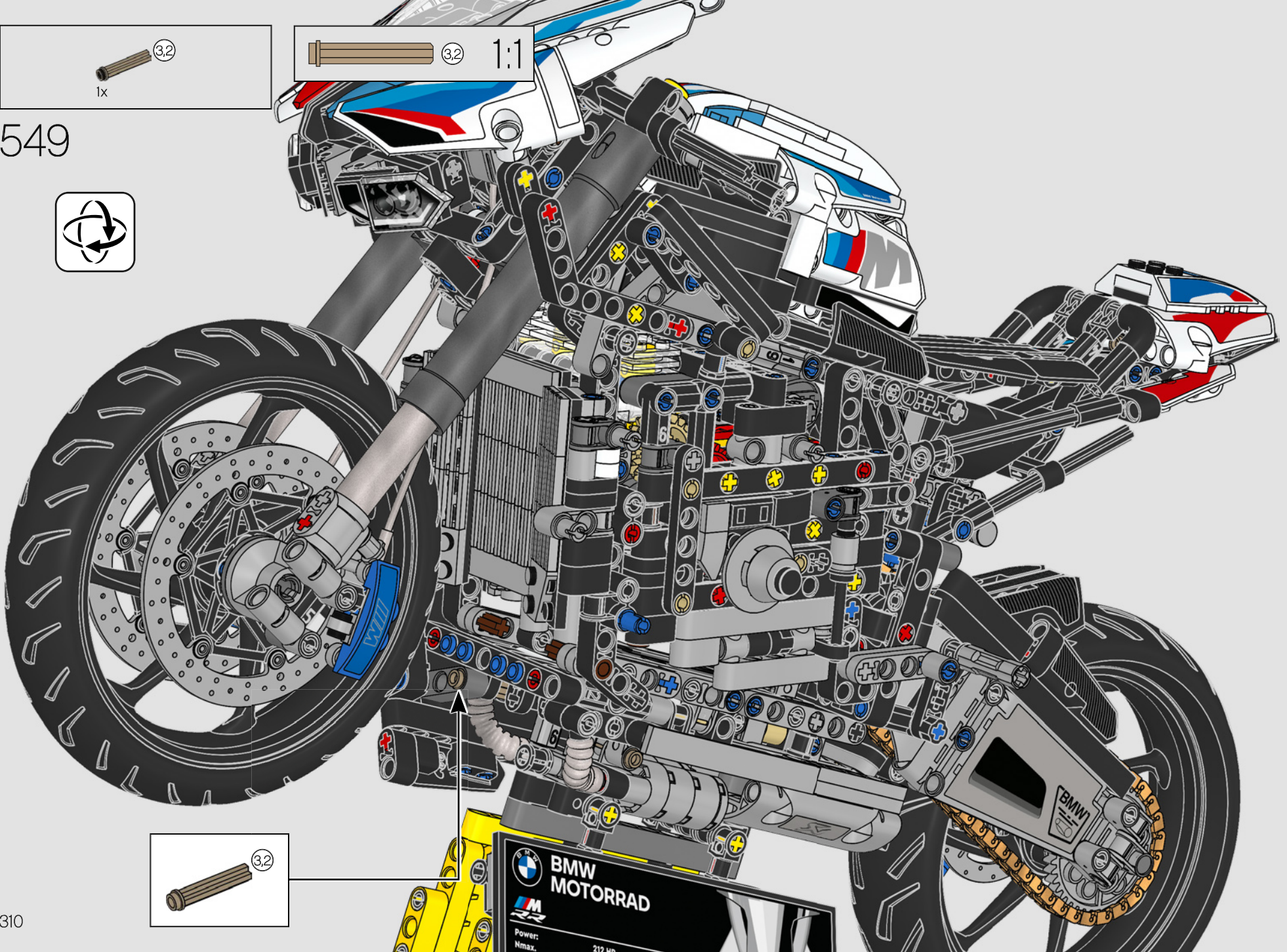
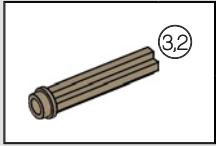

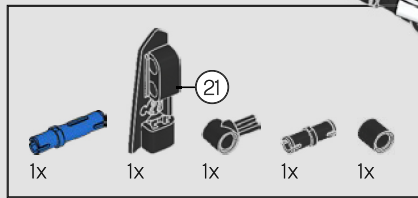

550

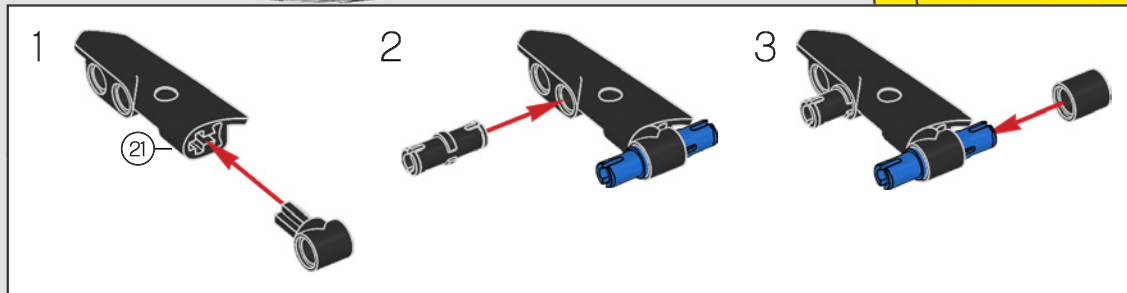
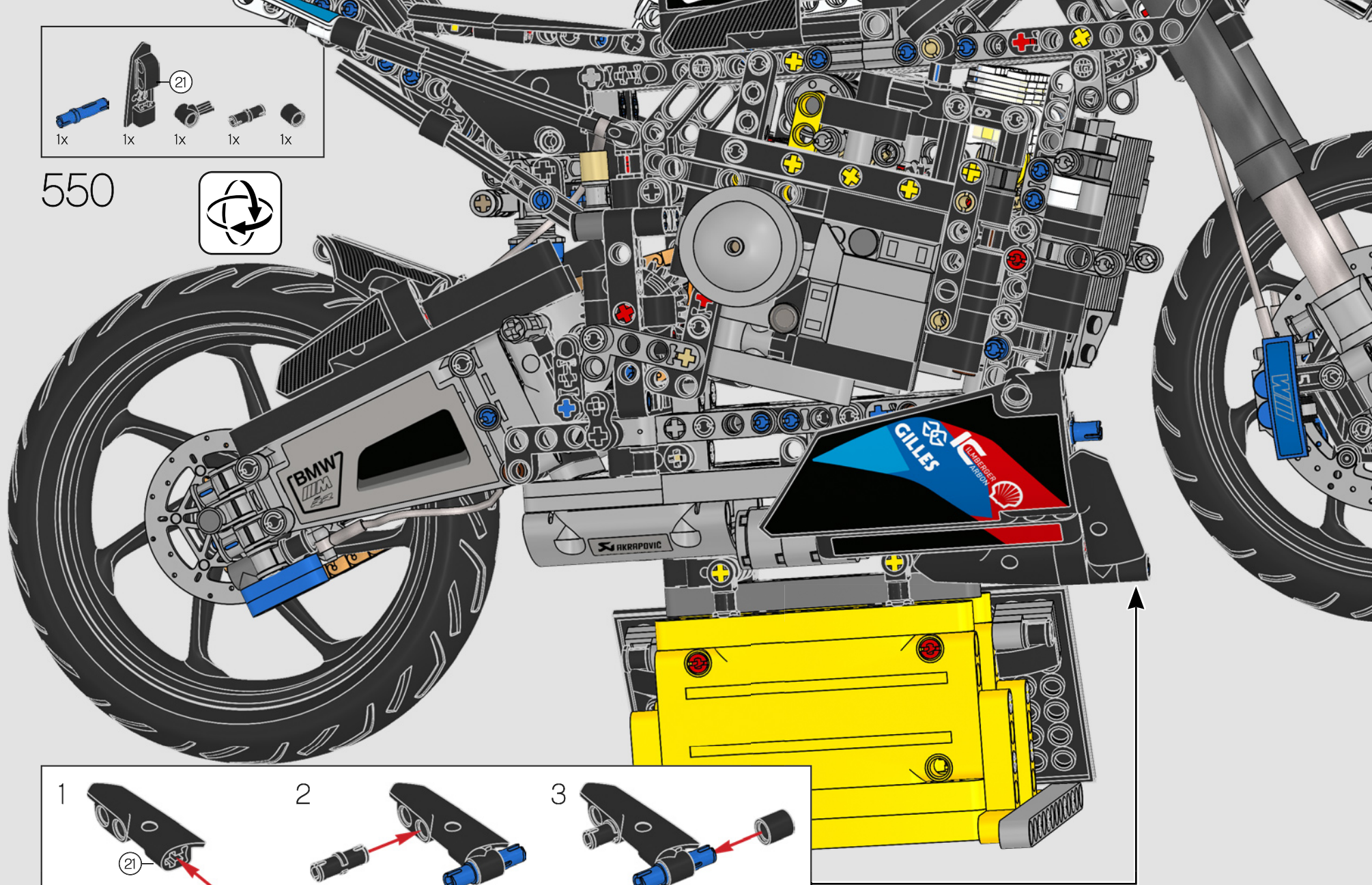

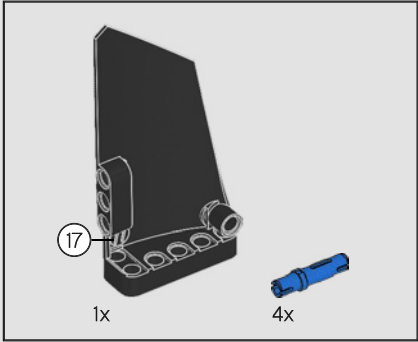
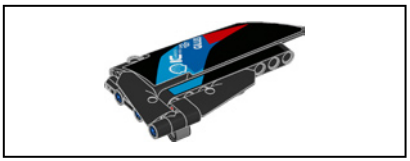

551

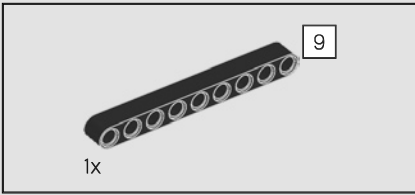
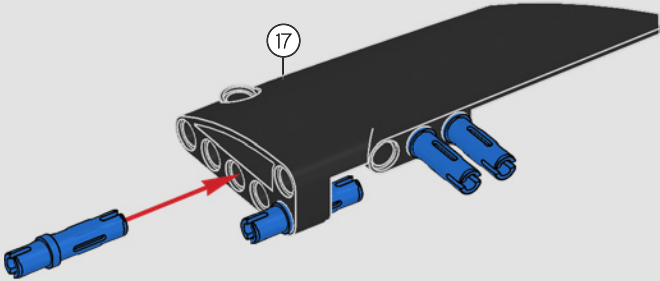

552

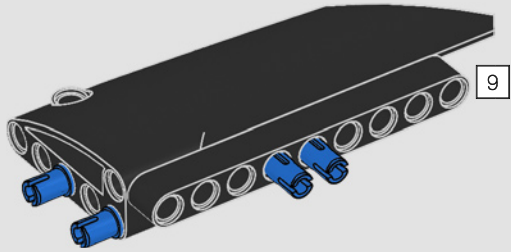

553

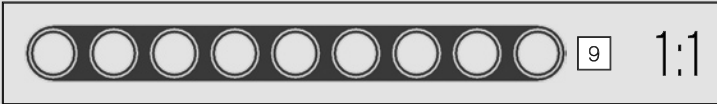
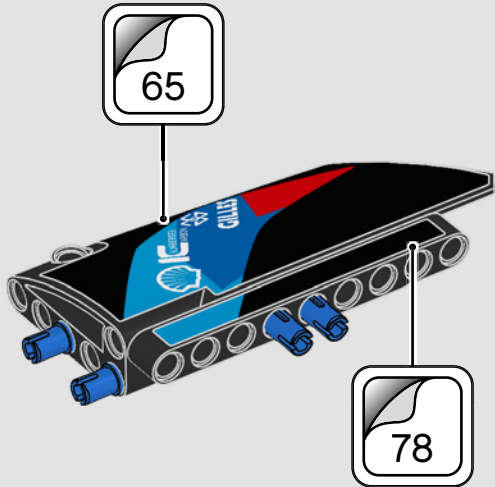

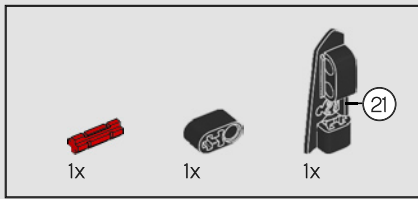

554

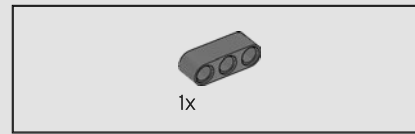
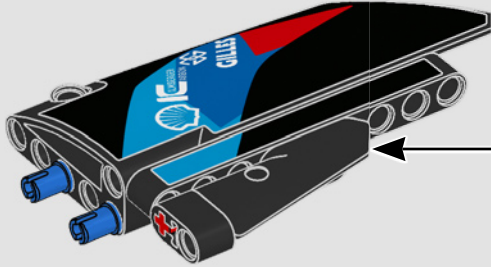
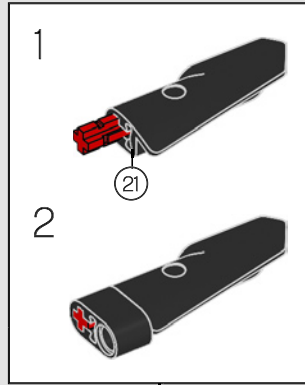

555

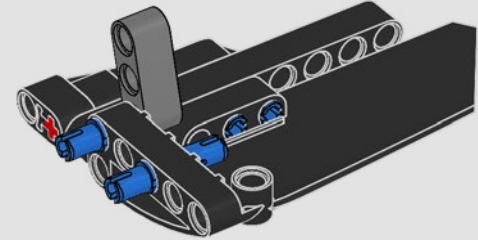
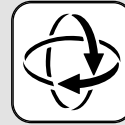

556

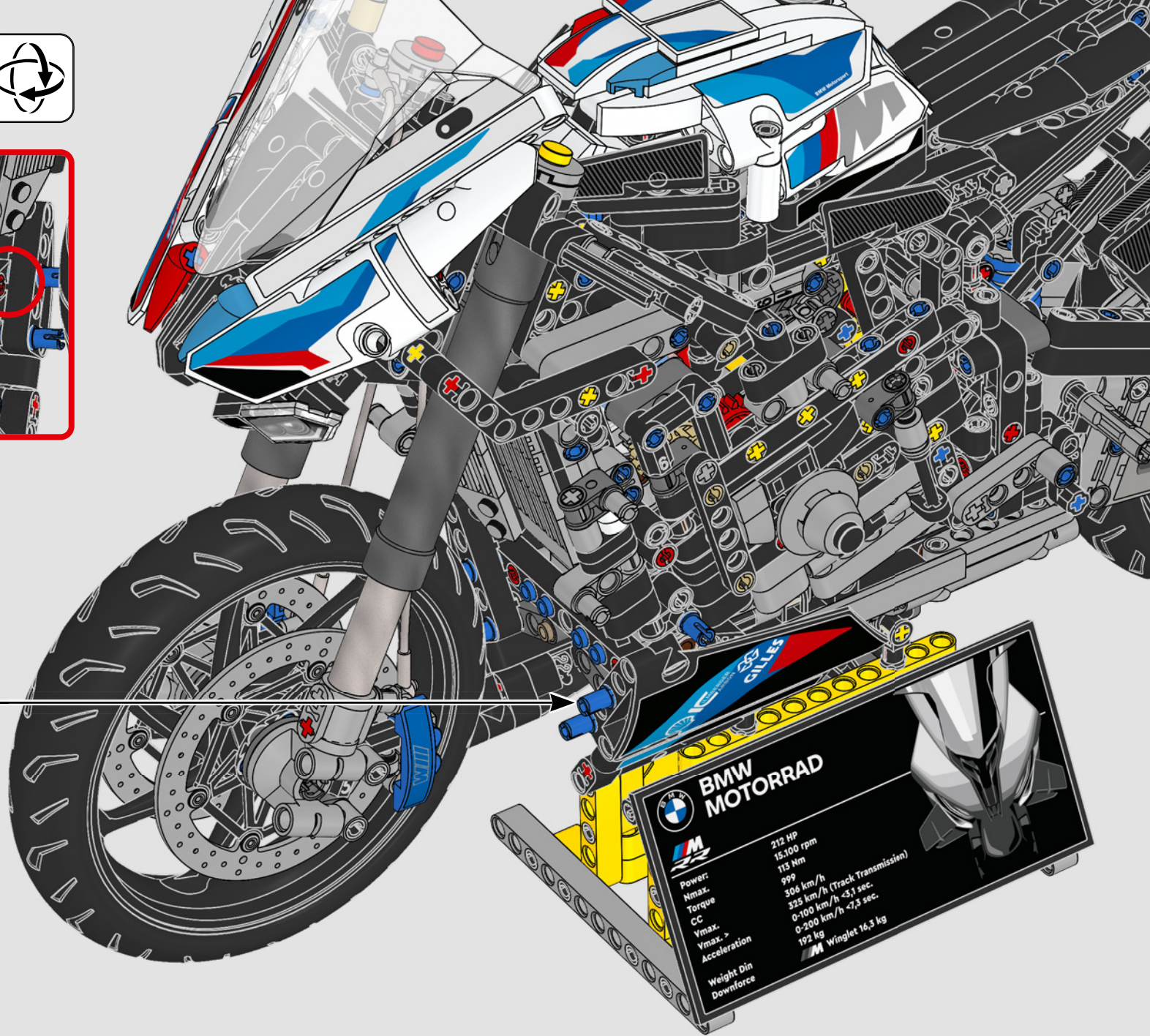
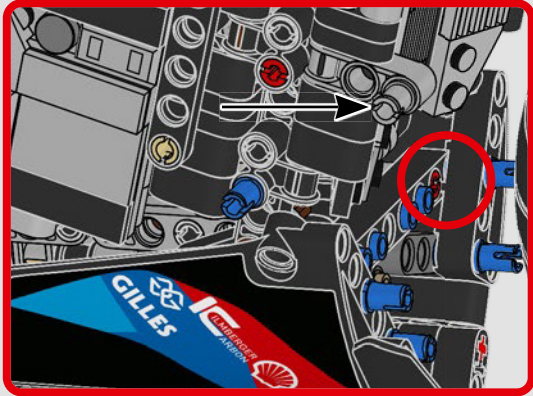
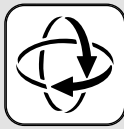

BMW MOTORRAD

Power:	212 HP
Nmax:	15.100 rpm
Torque:	113 Nm
CC	999
Vmax:	306 km/h
Vmax. >	325 km/h (Track Transmission)
Acceleration	0-100 km/h < 3,1 sec.
Weight Din	0-200 km/h < 7,3 sec.
Downforce	192 kg
	Winglet 16,3 kg

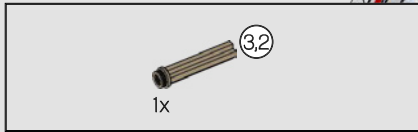

557

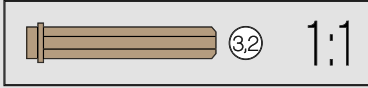
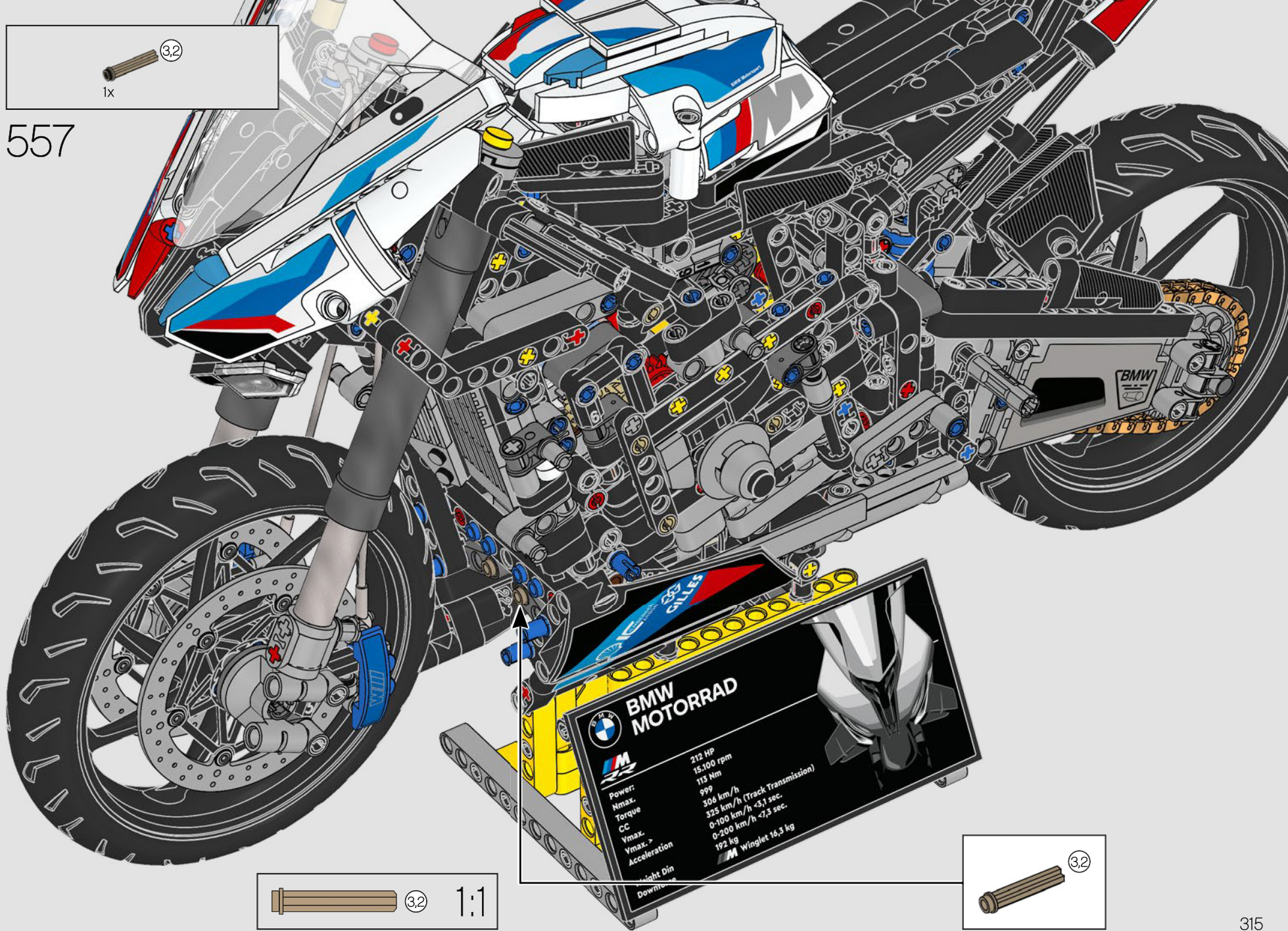

BMW MOTORRAD

Power:	212 HP
Nmax:	15,100 rpm
Torque:	115 Nm
CC:	999
Ymax:	306 km/h
Acceleration:	325 km/h (<3,1 sec.)
Weight Din:	0-100 km/h <7,3 sec.
Download:	192 kg
	Winglet 16,3 kg

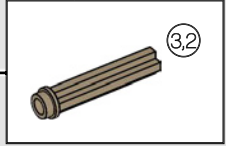

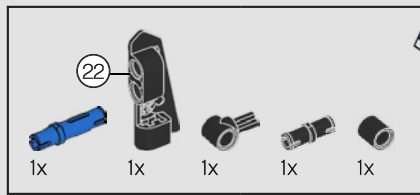

558

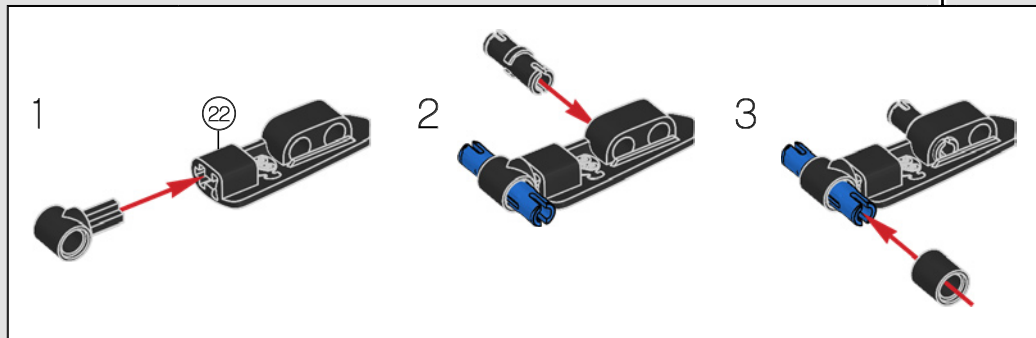
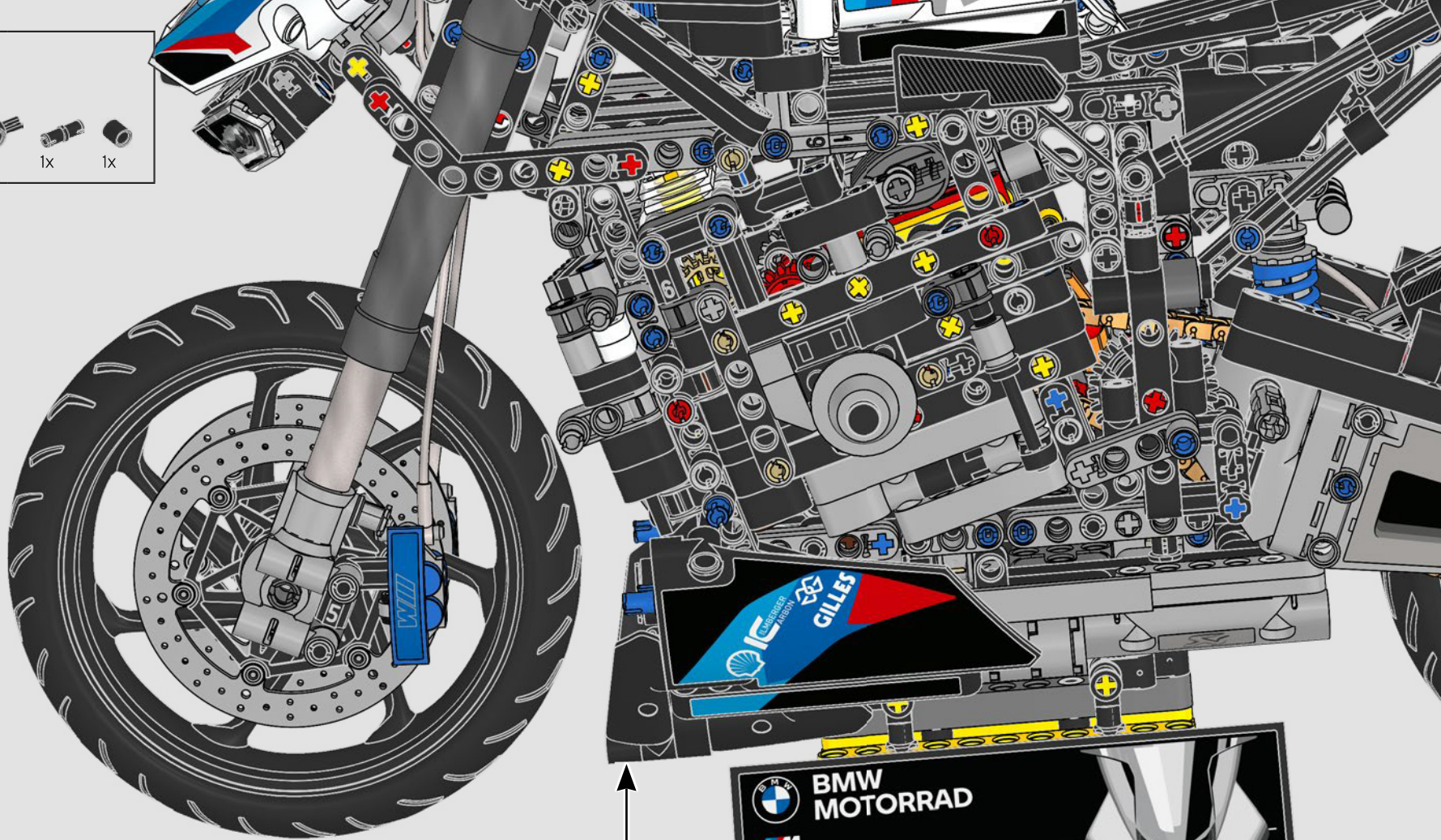

BMW MOTORRAD

Power:	212 HP
Nmax.	15.100 rpm
Torque	113 Nm
CC	999
Vmax.	306 km/h
Vmax. >	325 km/h (Track Transmission)
Acceleration	0-100 km/h <3,1 sec.
	0-200 km/h <7,3 sec.
Weight Din	192 kg
Downforce	M Winglet 16,3 kg

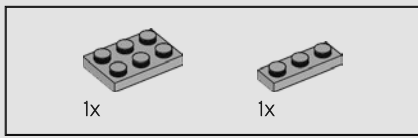

559

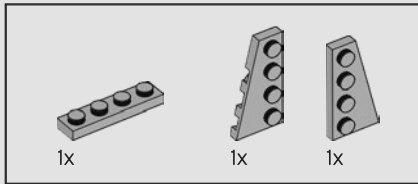
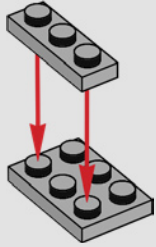

560

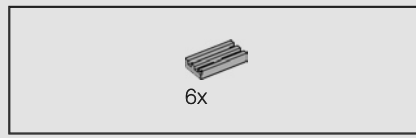
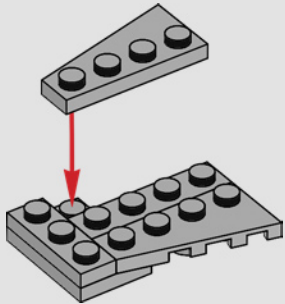

561

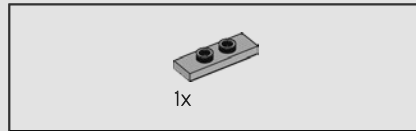
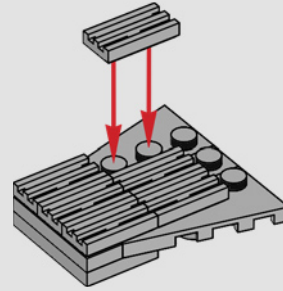

562

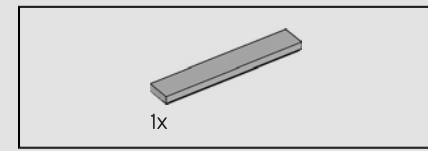
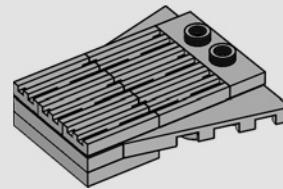

563

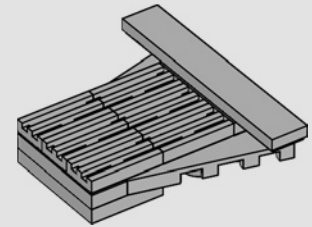

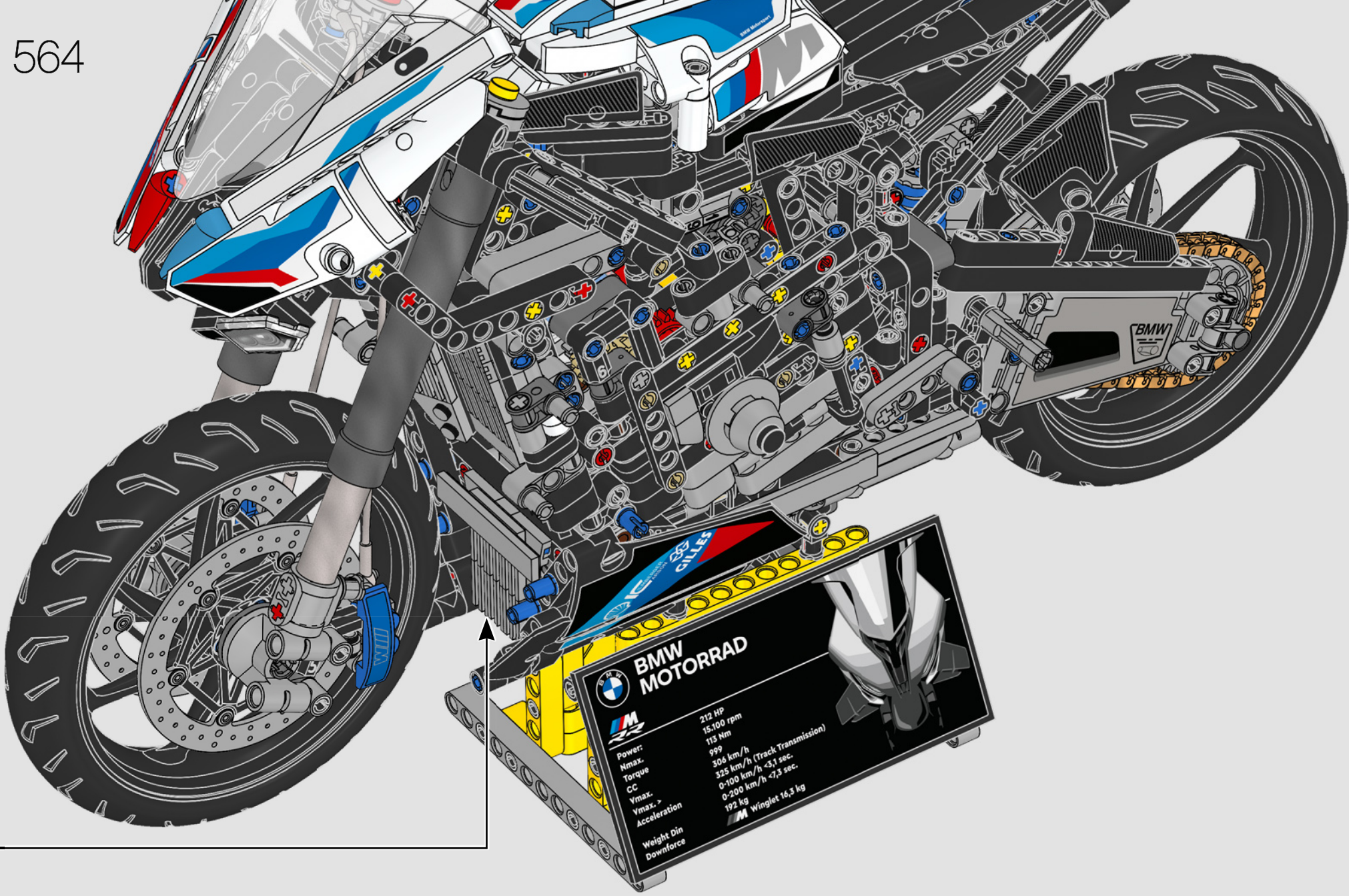

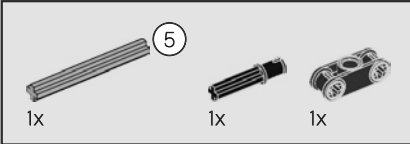
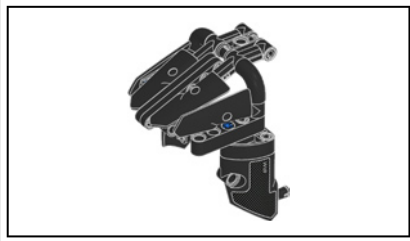

565

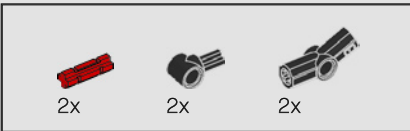
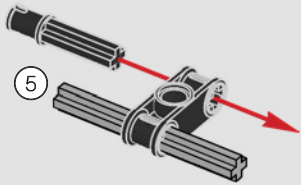

566

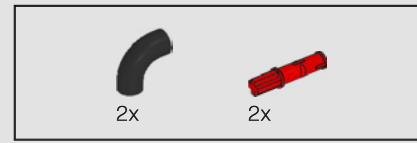
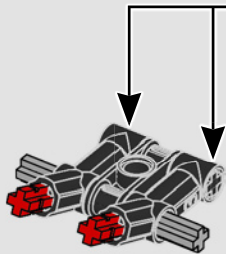
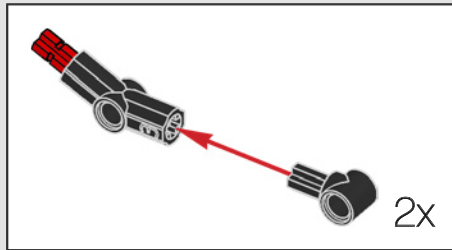

567

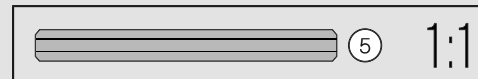
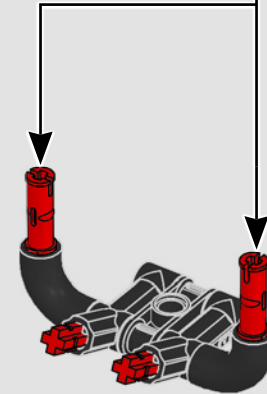
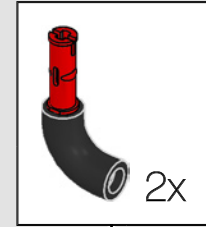

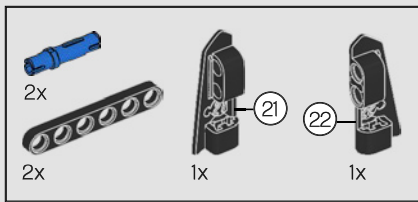

568

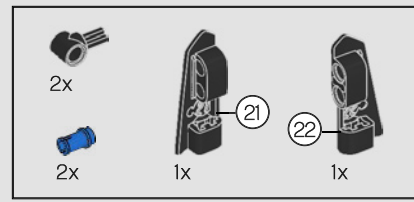
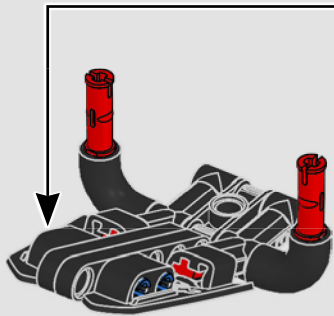
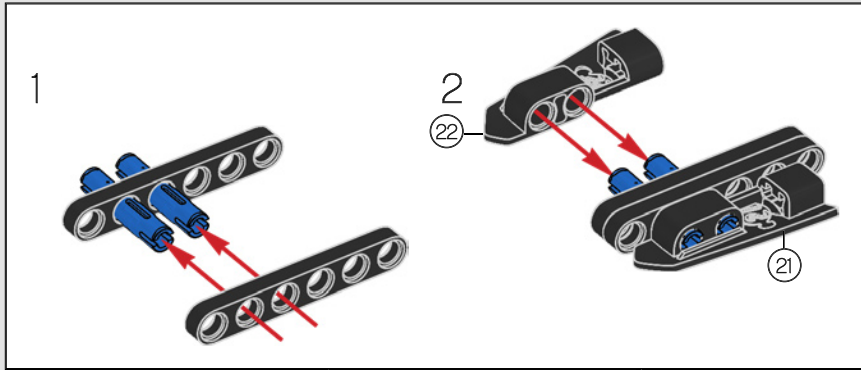
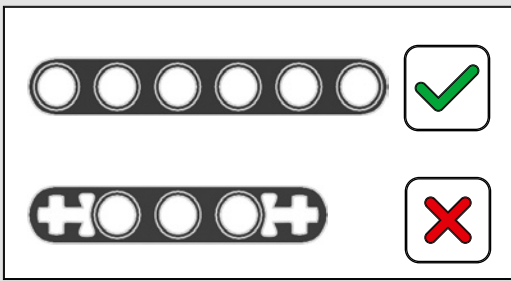

569

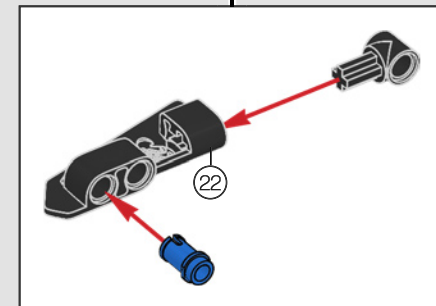
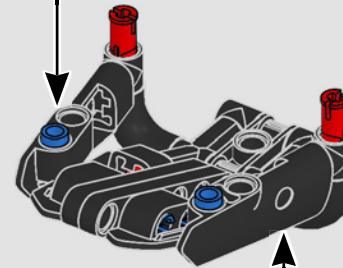
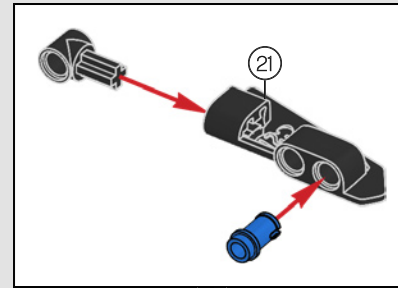

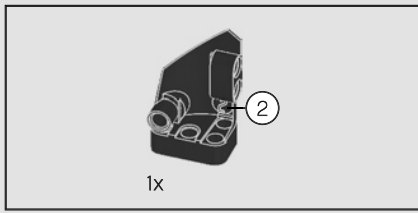

570

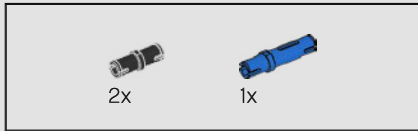
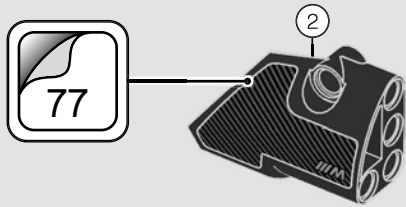

571

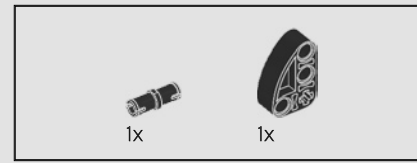
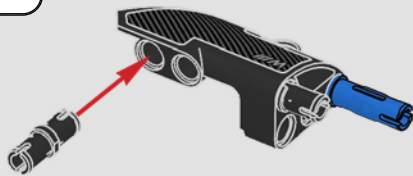

572

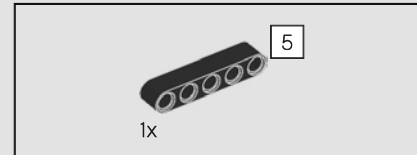
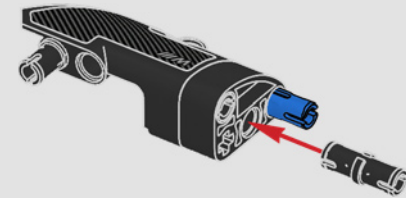

573

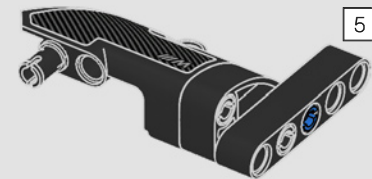

574

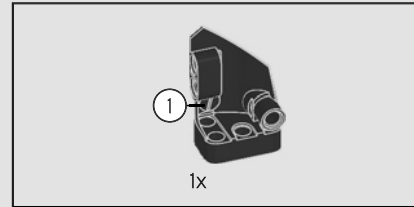
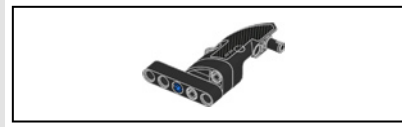
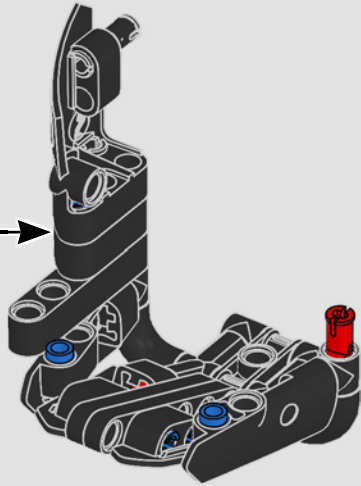

575

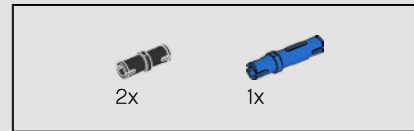
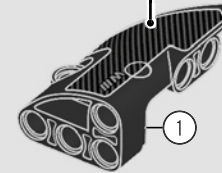

576

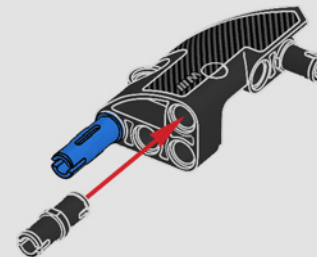

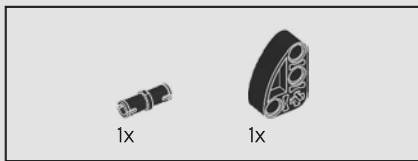

577

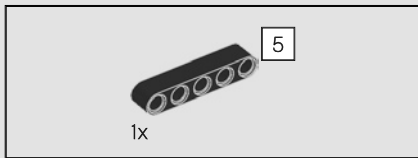
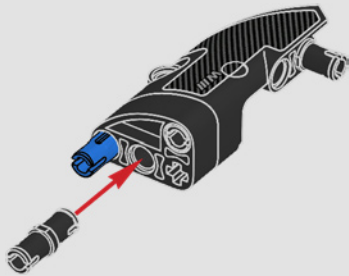

578

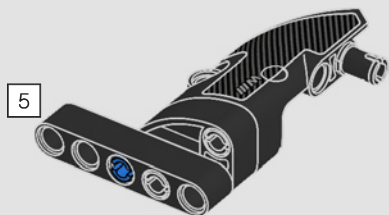

579

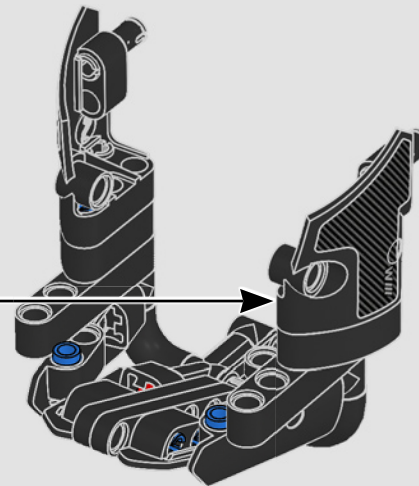

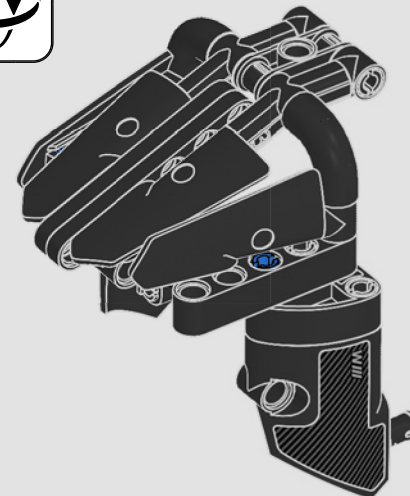
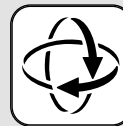

580

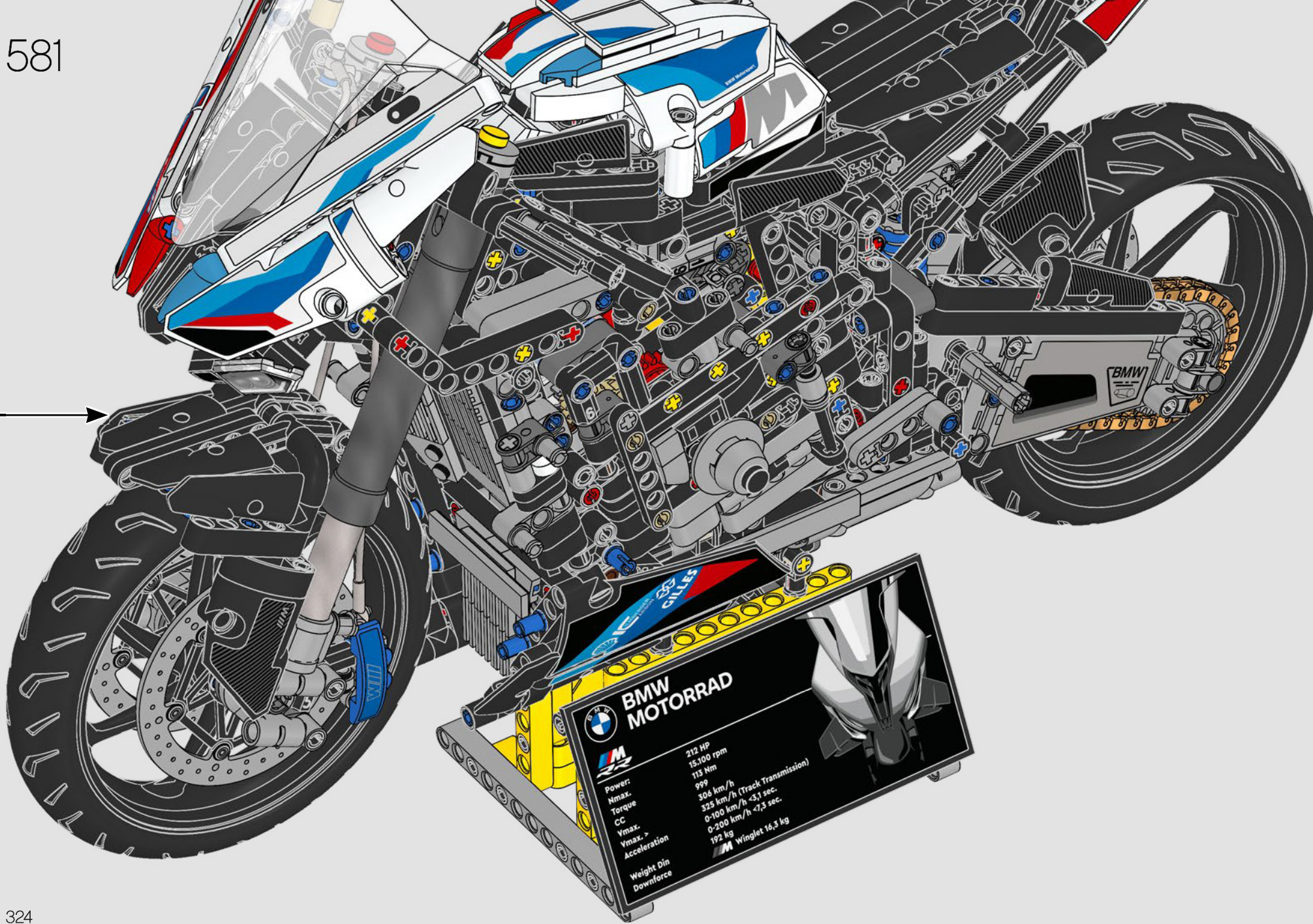



BMW MOTORRAD

Power: 212 HP
 Nmax: 15,100 rpm
 Torque: 118 Nm
 CC: 999
 Vmax: 306 km/h (Track Transmission)
 Acceleration: 0-100 km/h \approx 3,1 sec.
 0-200 km/h \approx 7,3 sec.
 Weight Din: 192 kg
 Downforce: Winglet 16,3 kg



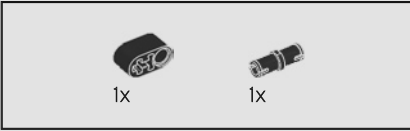
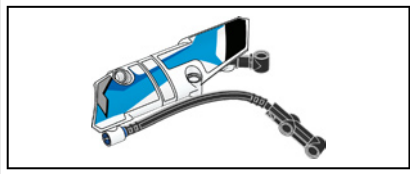



1x

1x

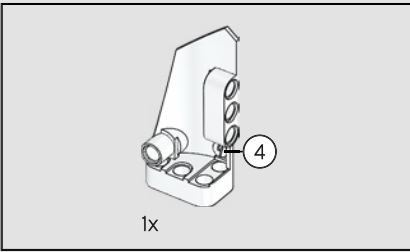
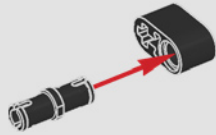
582



1x

583

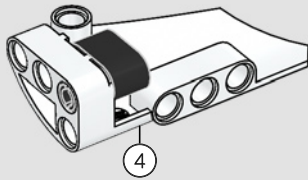

4

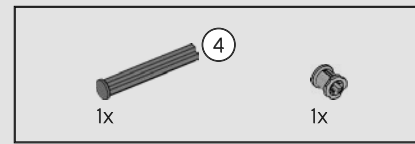

1x

1x

584

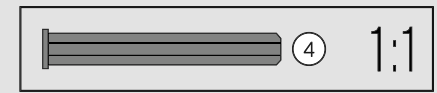

4

1:1

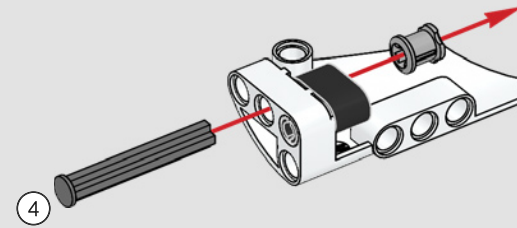

4

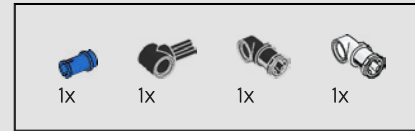

1x

1x

1x

1x

585

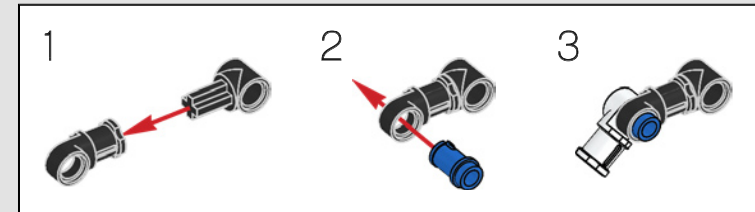

1

2

3

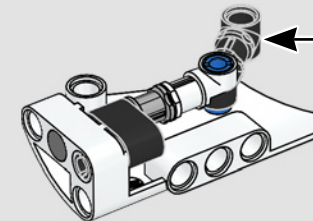

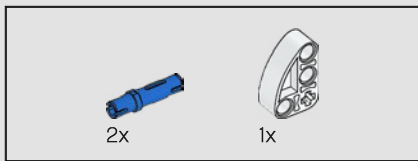

586

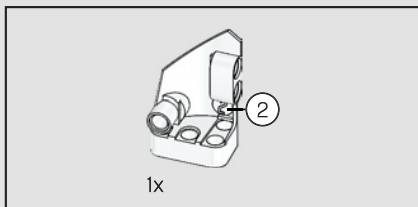
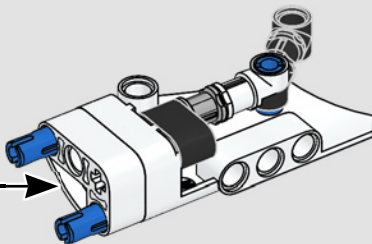
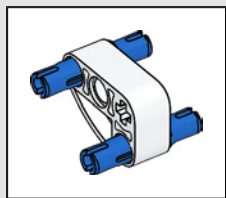

587

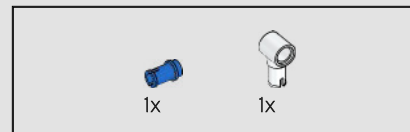
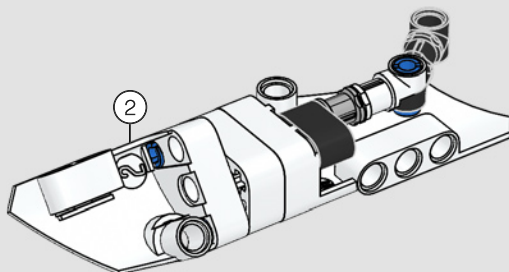

588

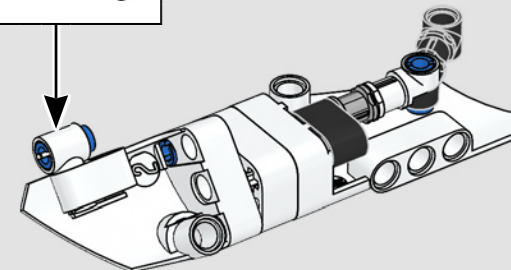
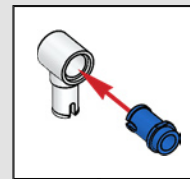

589

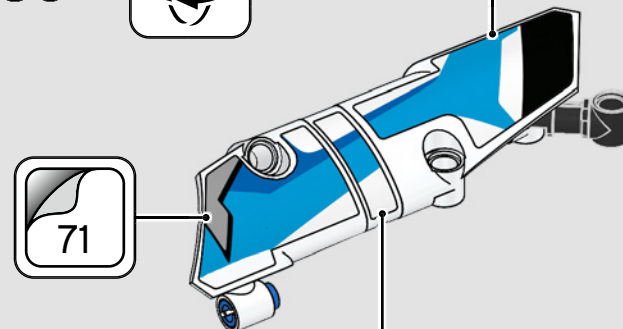
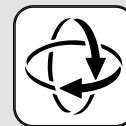

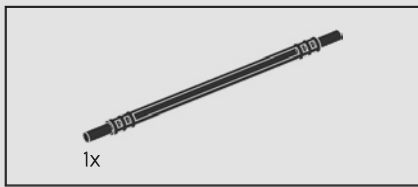

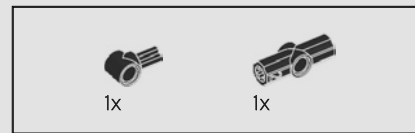
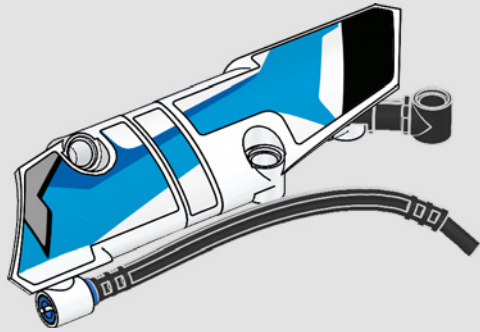

590

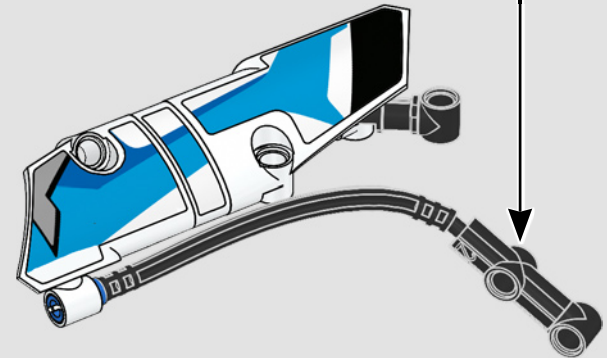
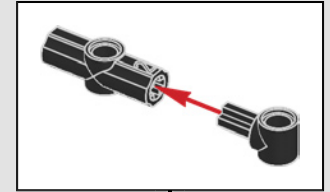

591

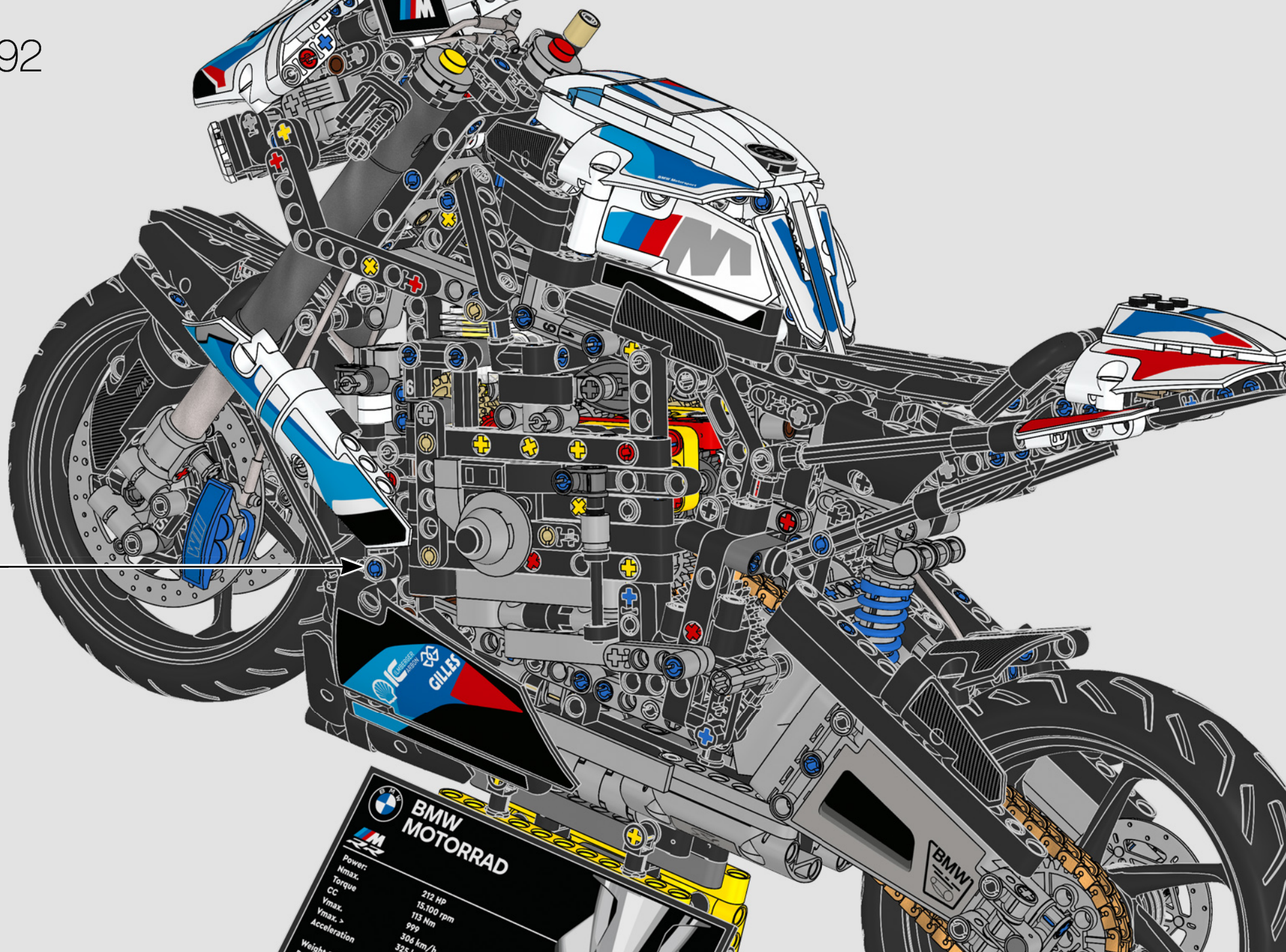



 **BMW MOTORRAD**

Power:	212 HP
Nmax:	15,100 rpm
Torque	113 Nm
CC	999
Vmax >	306 km/h
Acceleration	325 s
Weight	

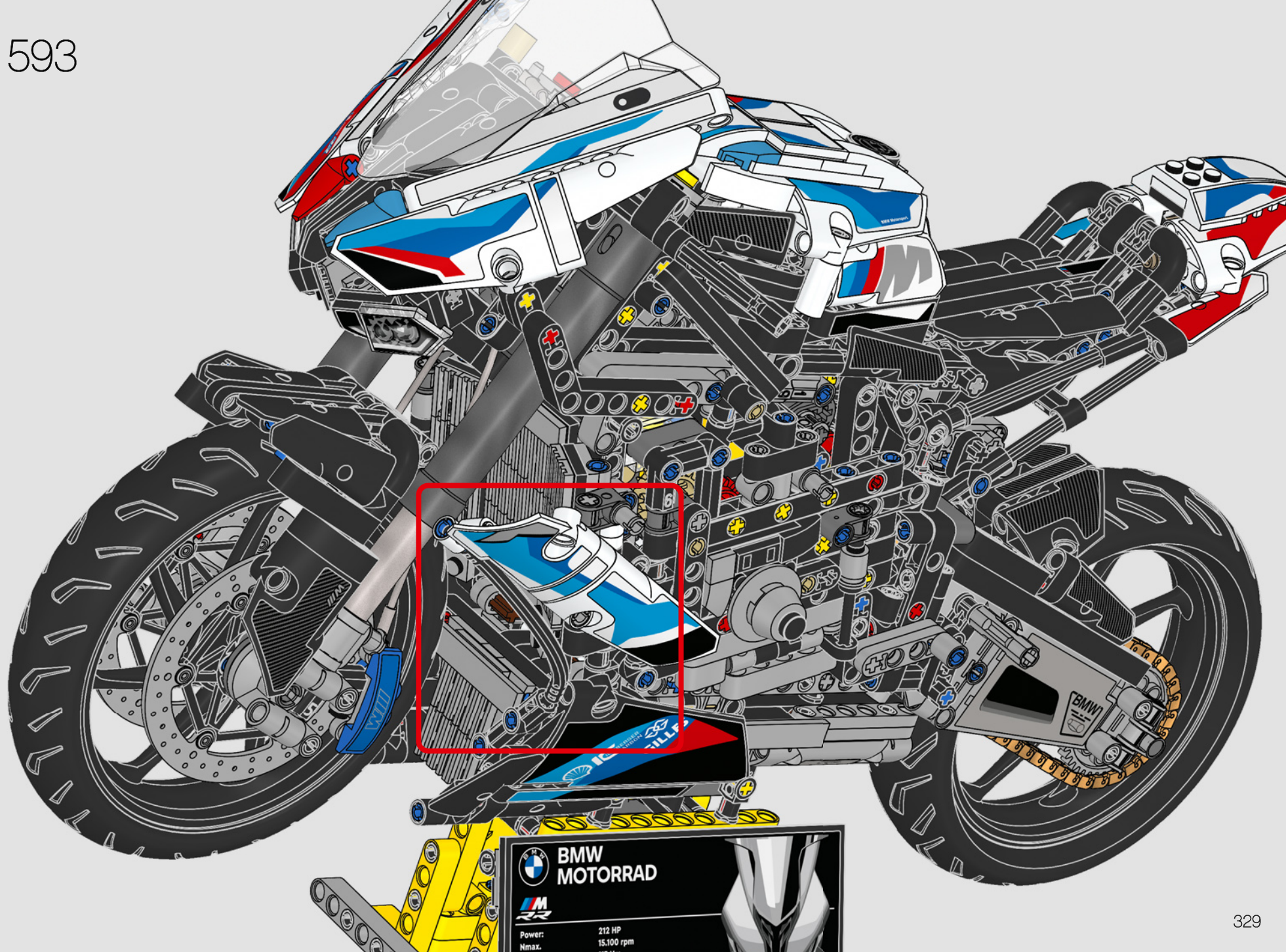

 **BMW
MOTORRAD**



Power: 212 HP
Nmax. 15,100 rpm

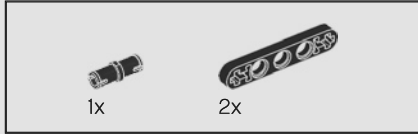
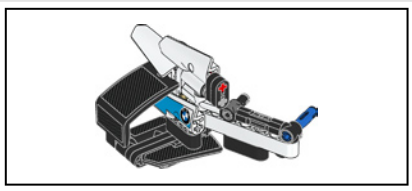

594

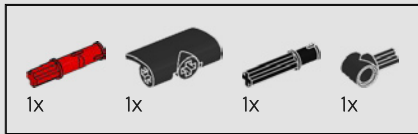
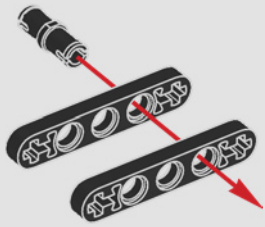

595

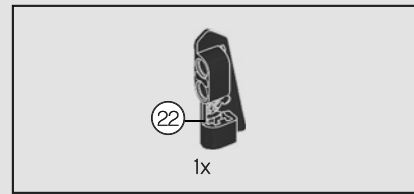
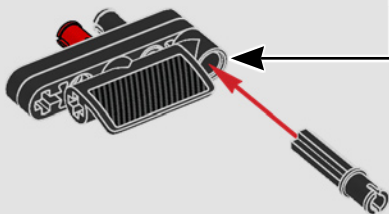
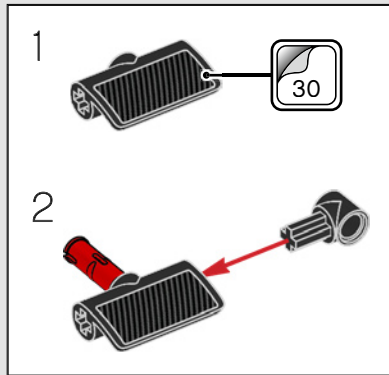

596

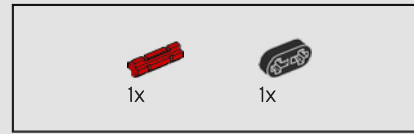
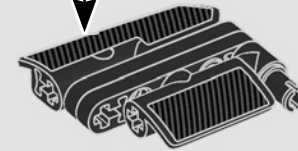
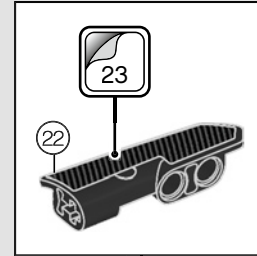

597

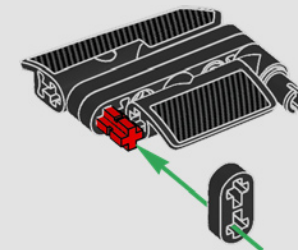

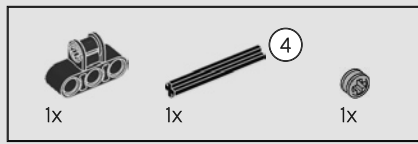

598

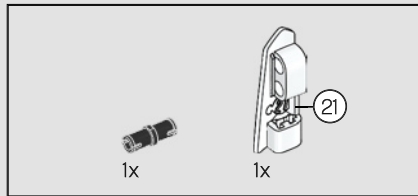
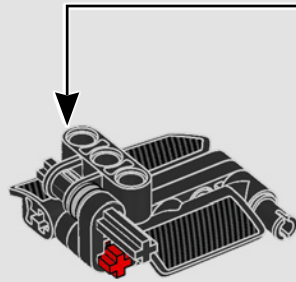
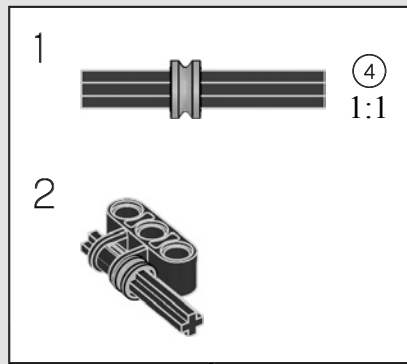

599

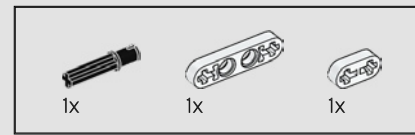
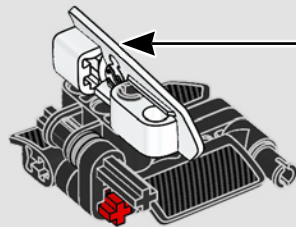
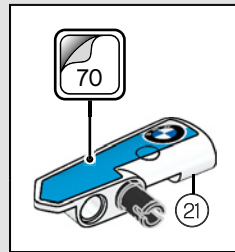

600

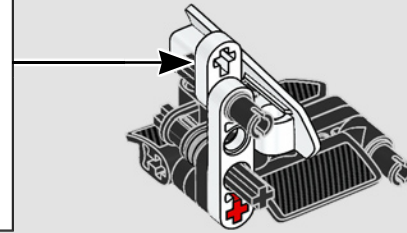
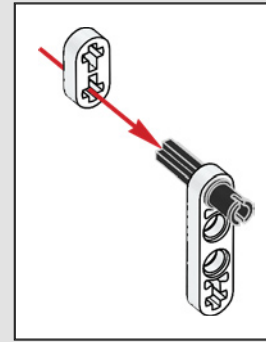

601

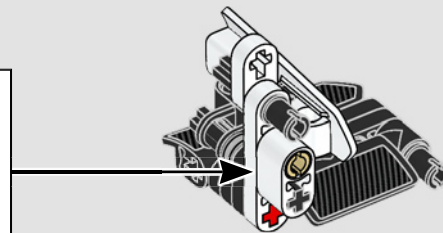
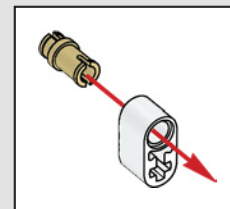

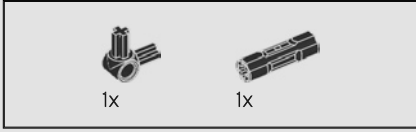
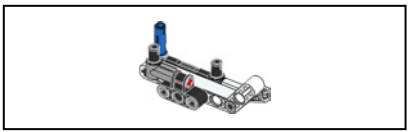

602

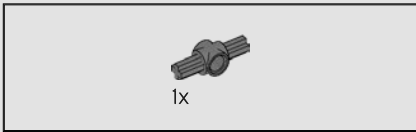
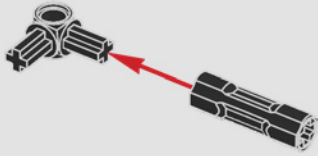

603

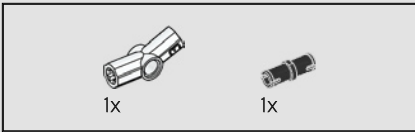
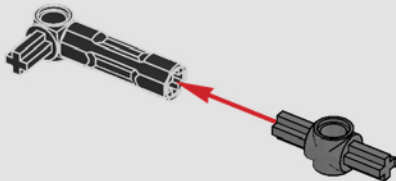

604

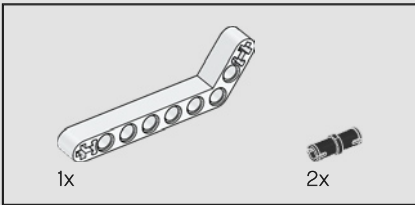
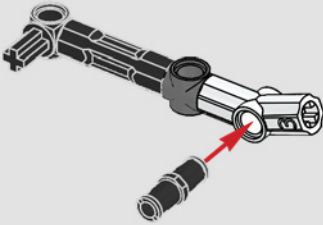

605

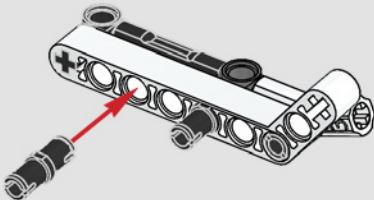

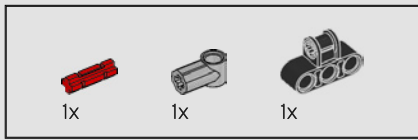

606

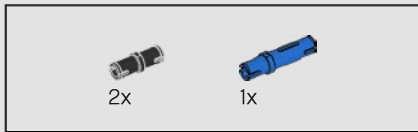
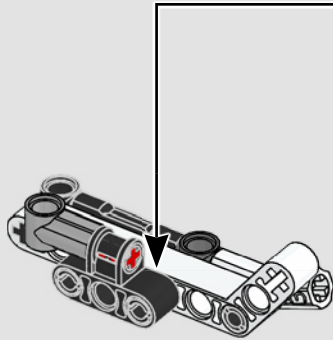
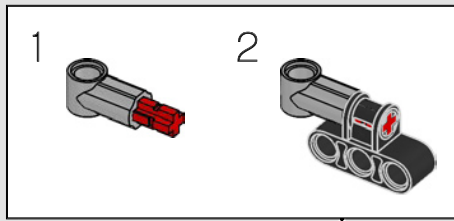

607

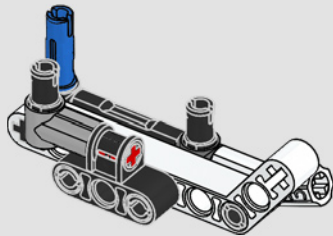

608

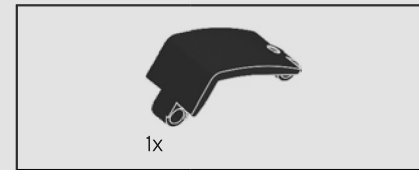
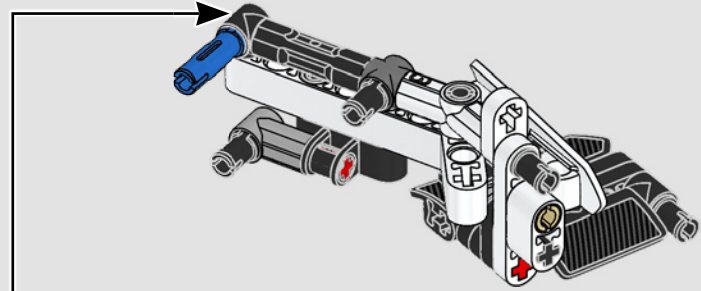

609

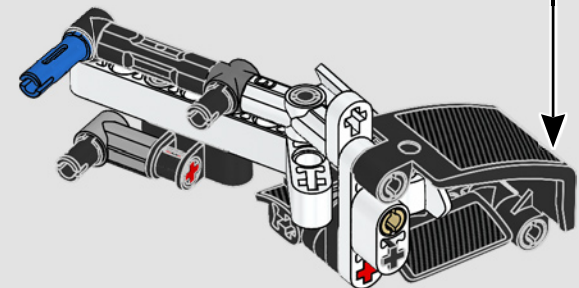
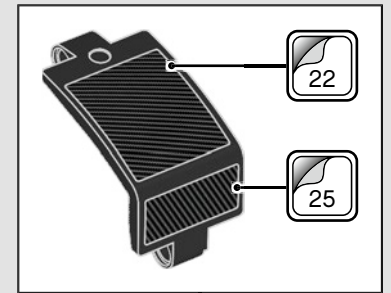

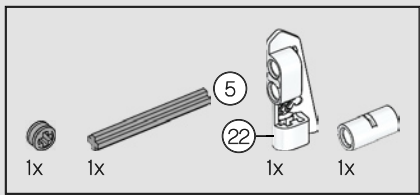

610

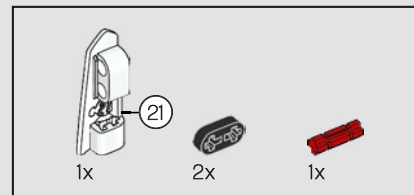
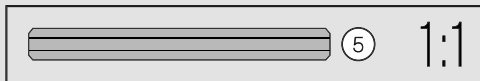
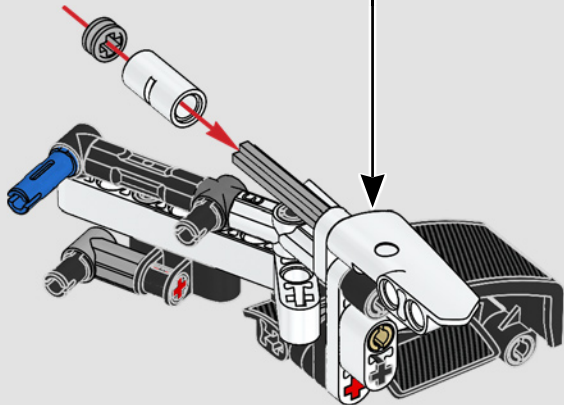
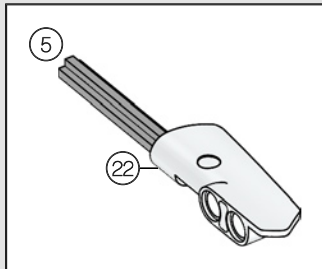

611

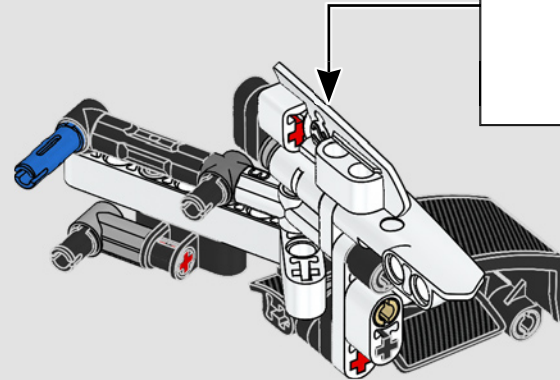
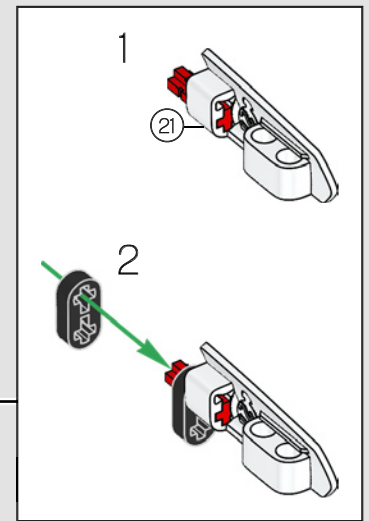

612

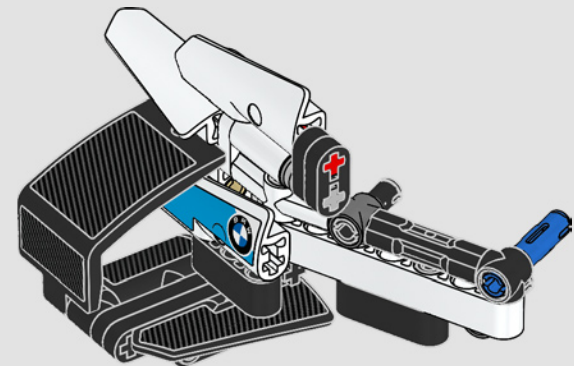

613

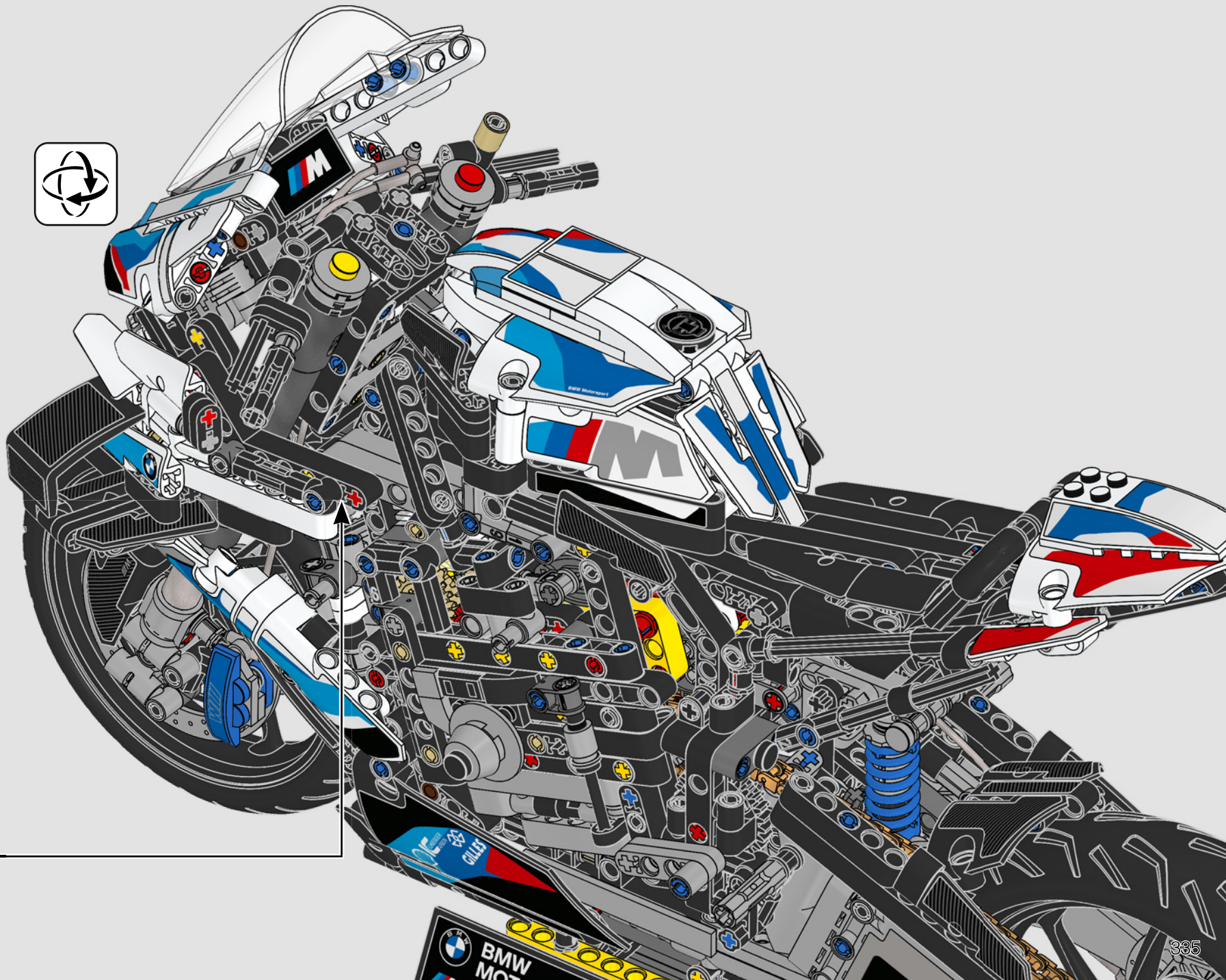

BMW
MOT

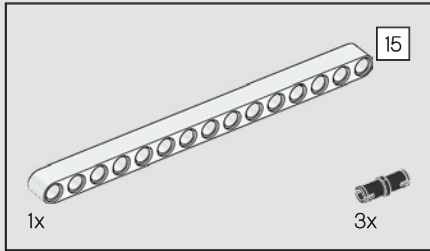
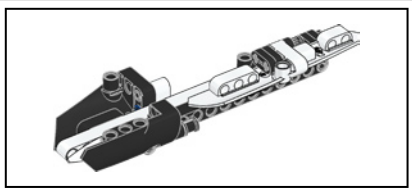

614

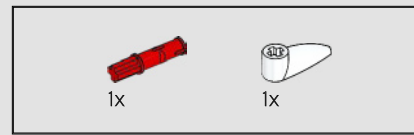
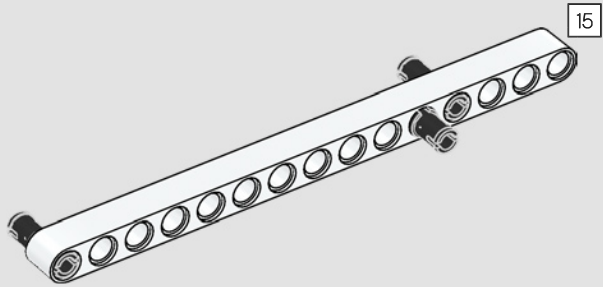

615

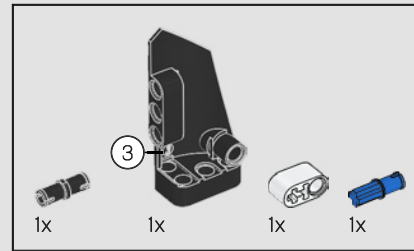
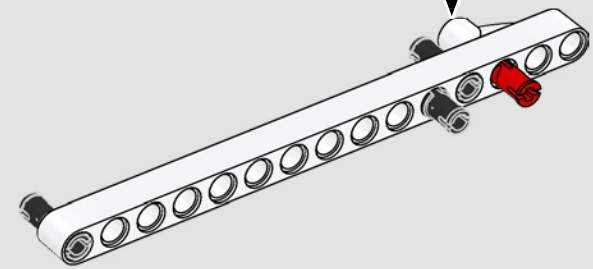
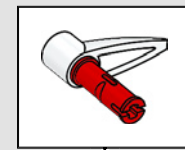

616

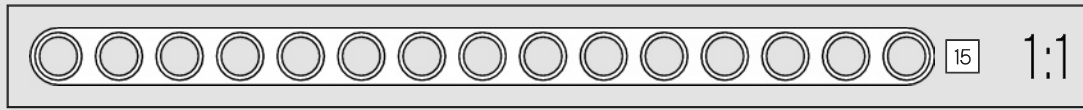
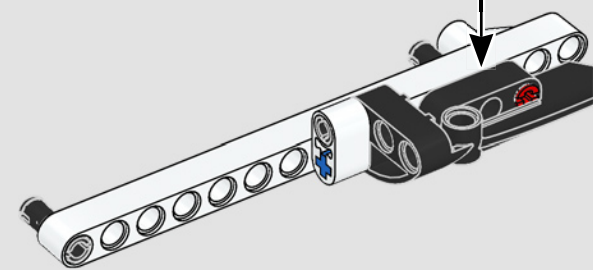
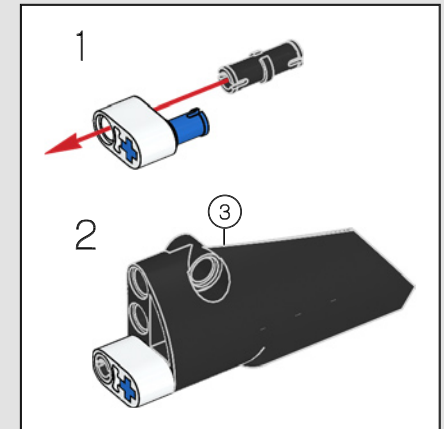

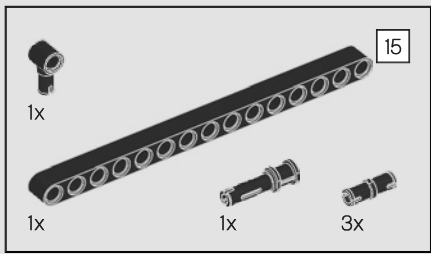

617

1

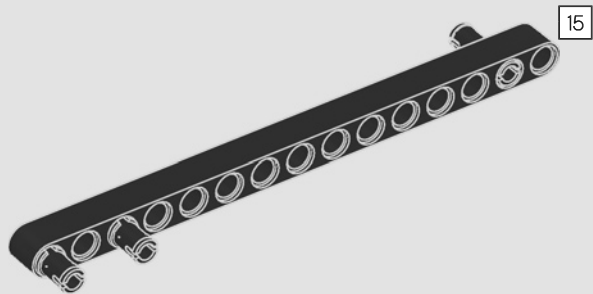

2

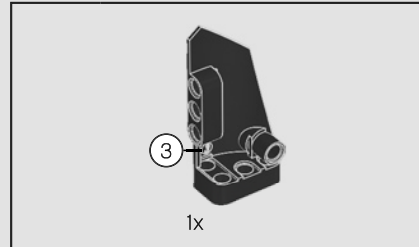
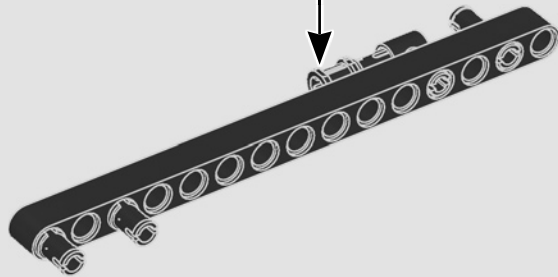
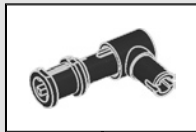

618

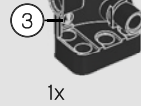

1x

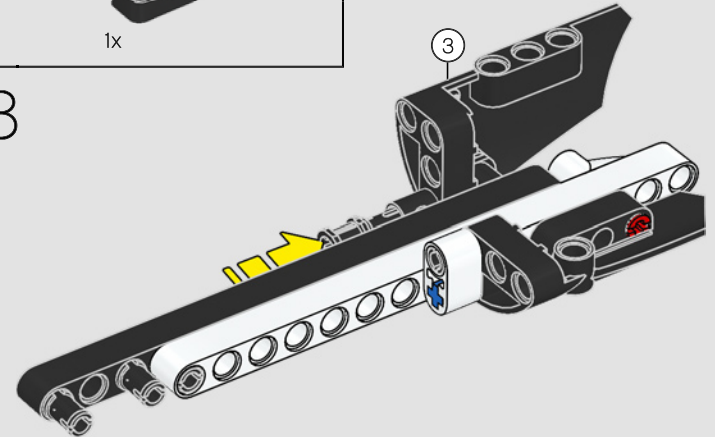
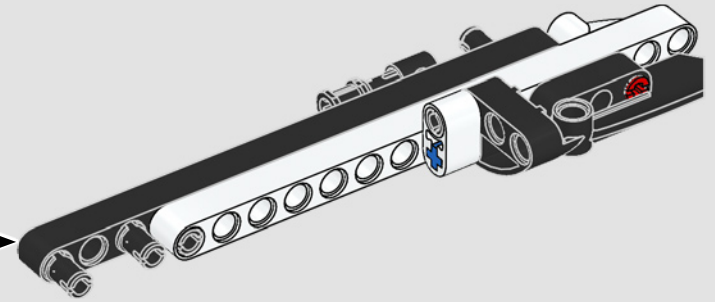

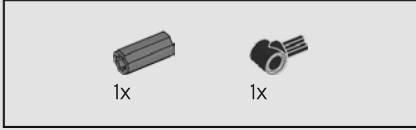
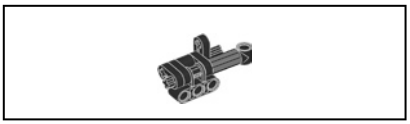

619

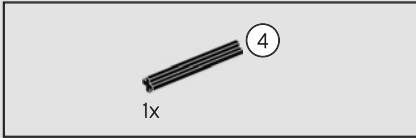
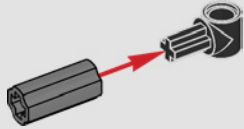

620

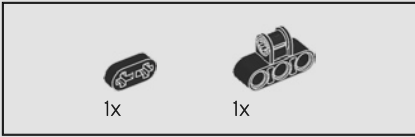
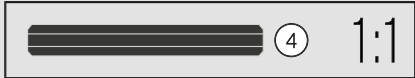
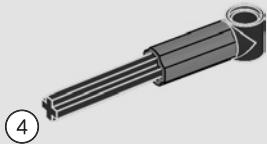

621

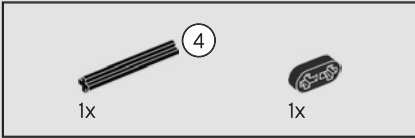
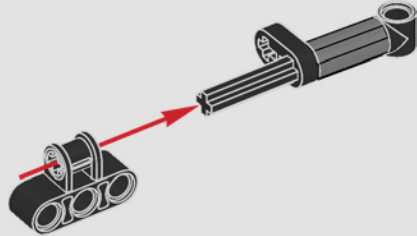

622

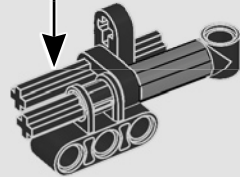



623

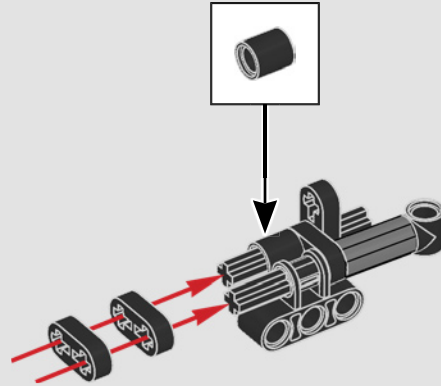

624

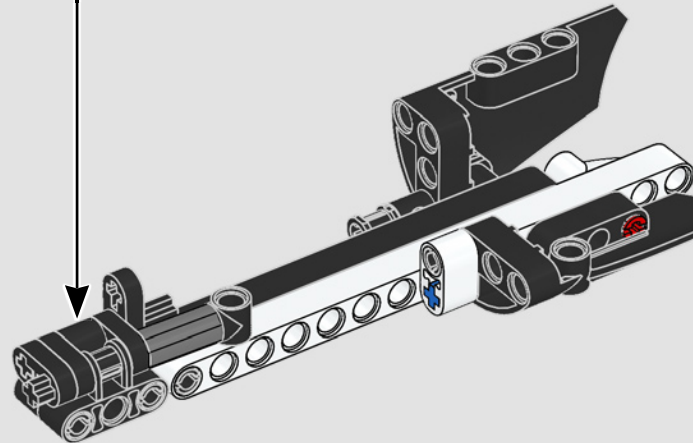

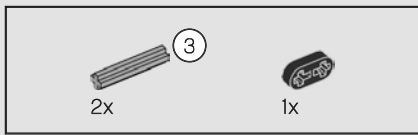

625

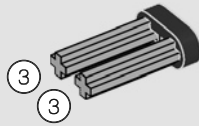
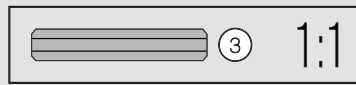

626

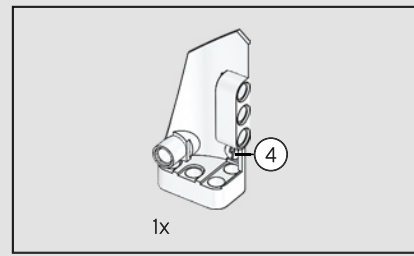
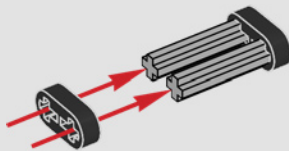

627

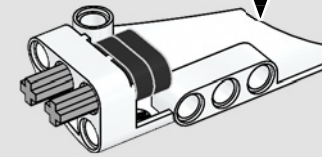
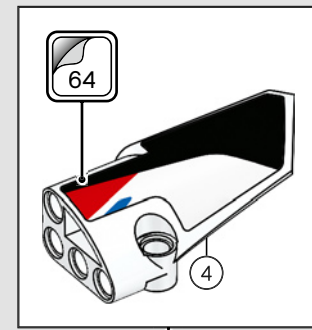

628

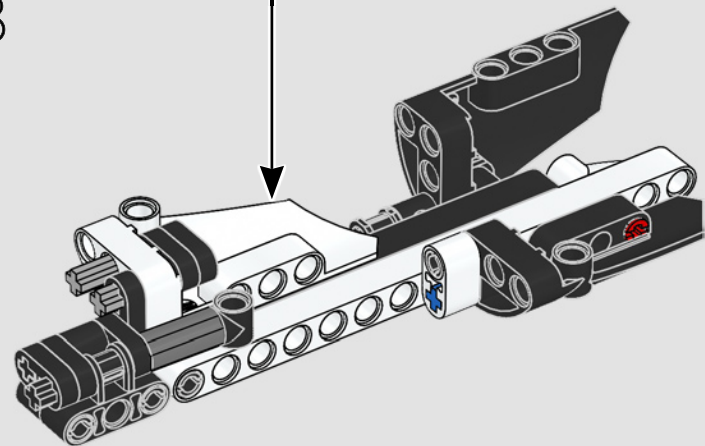

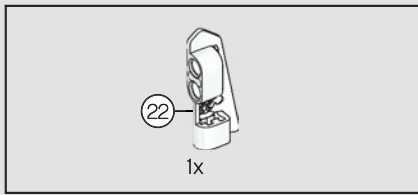

629

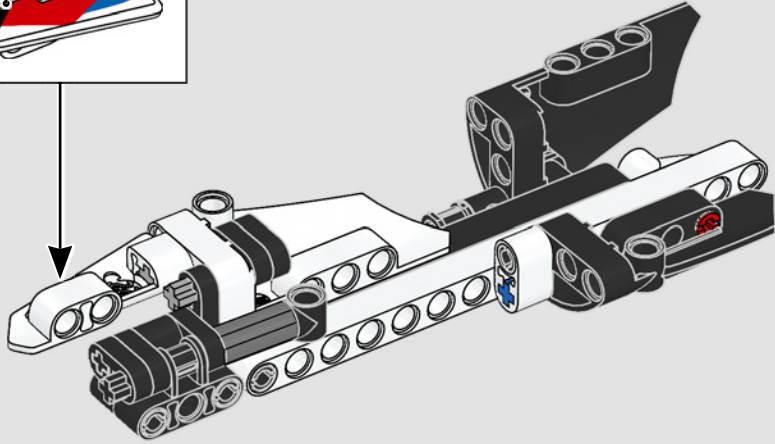
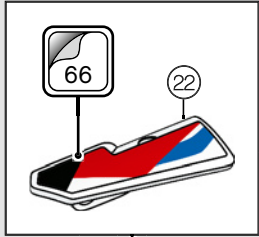

630

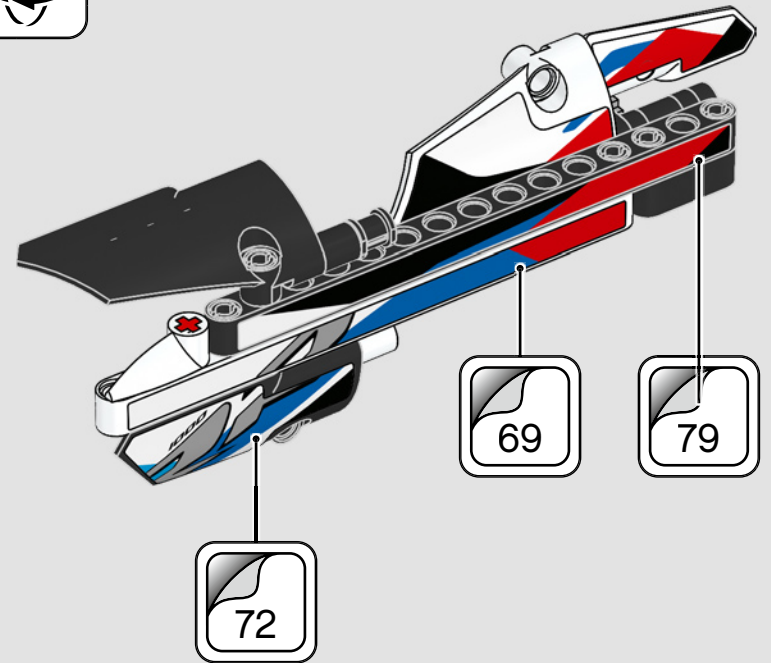
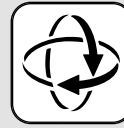

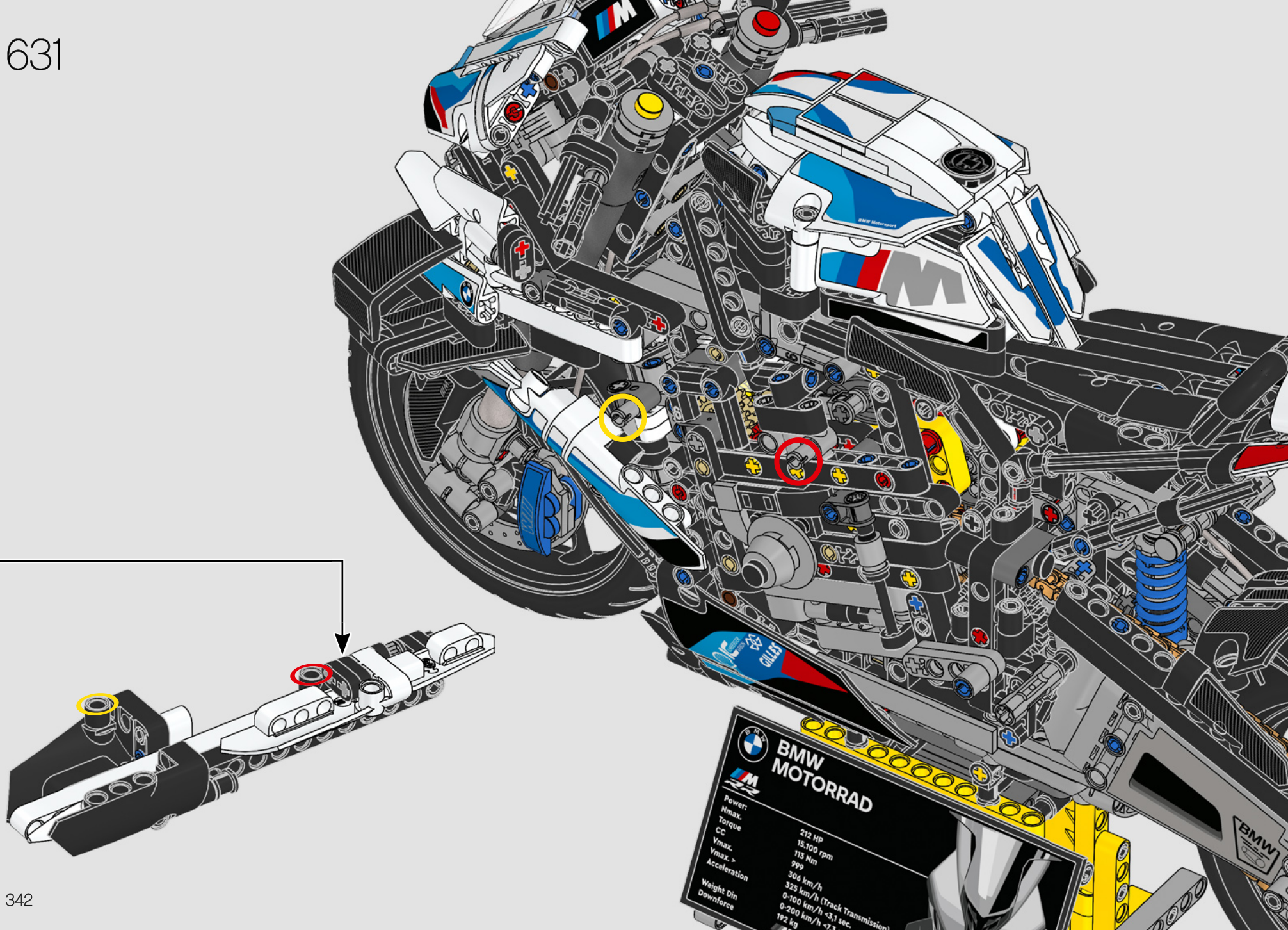

632

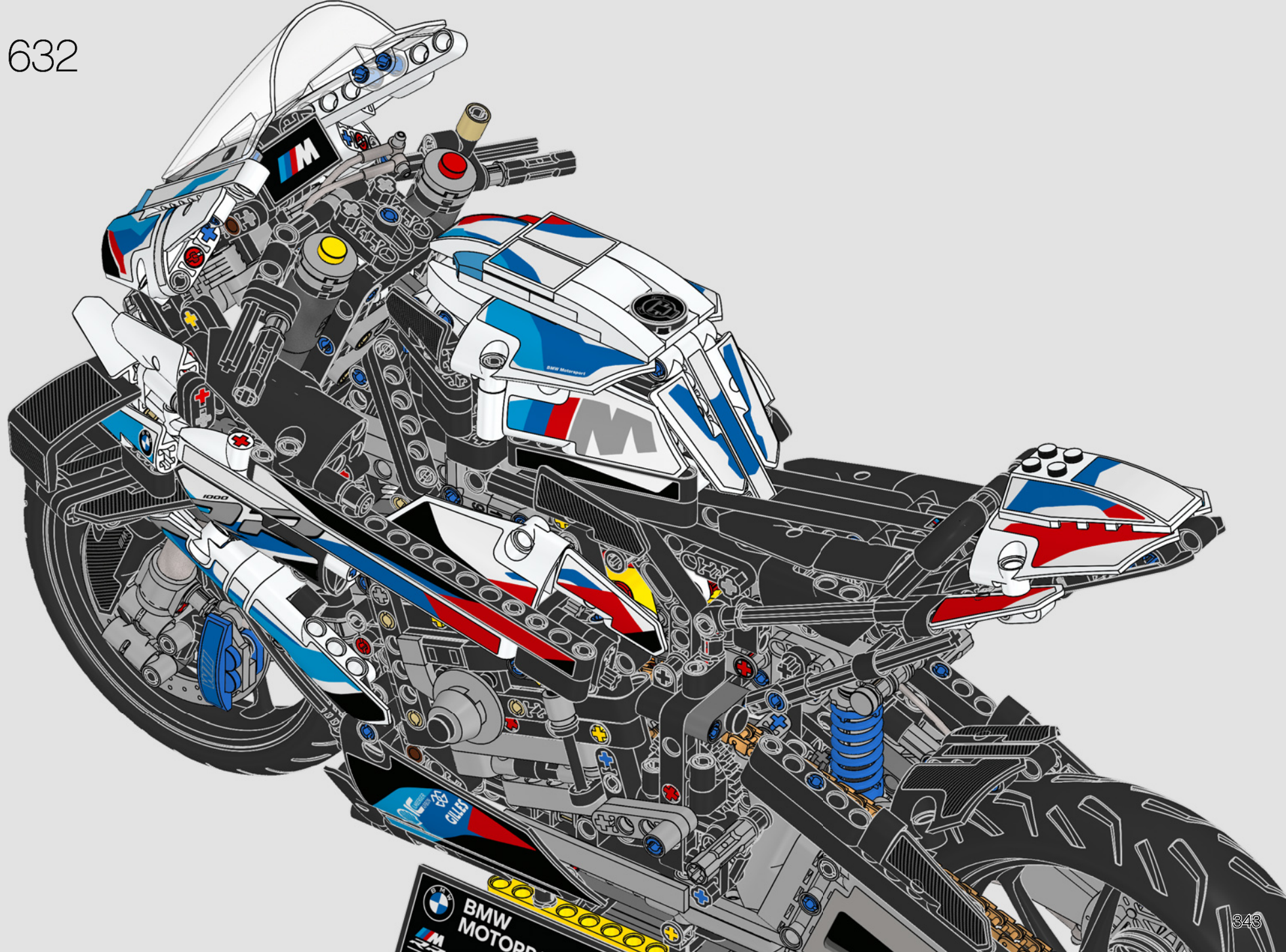

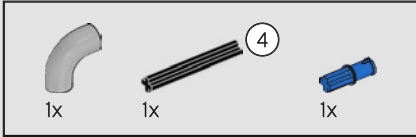
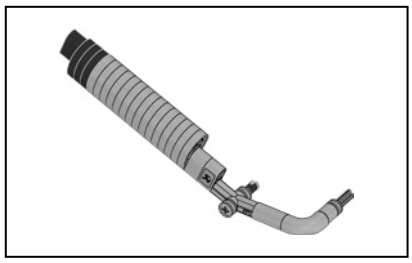

633

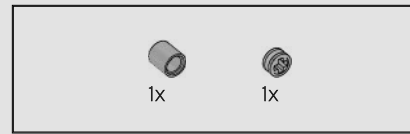
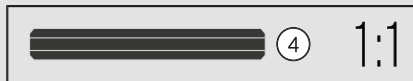
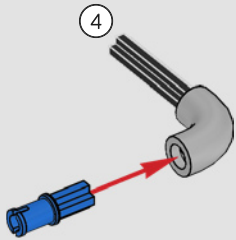

634

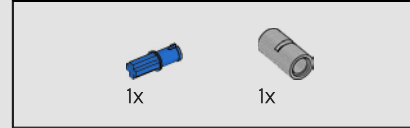
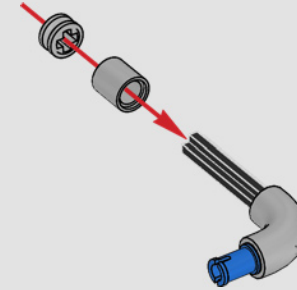

635

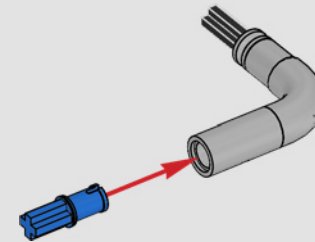

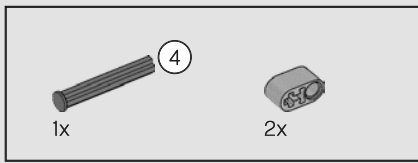

636

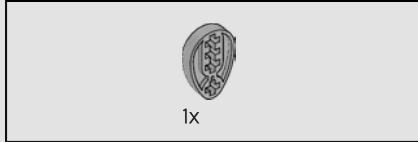
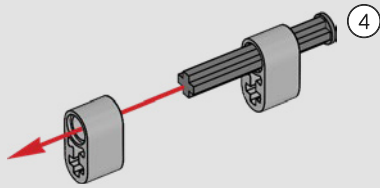

637

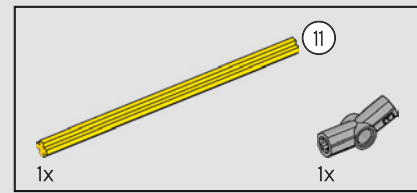
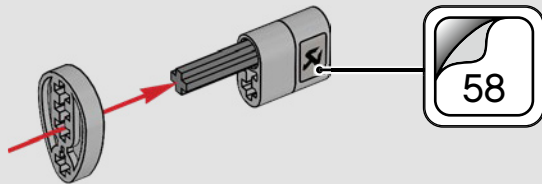

638

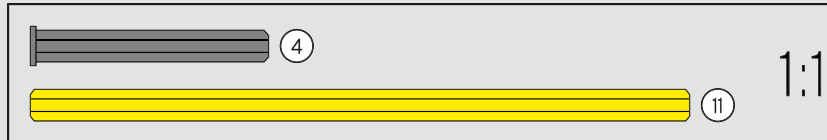
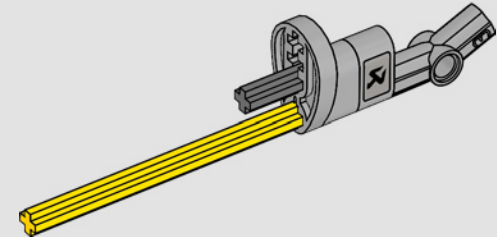
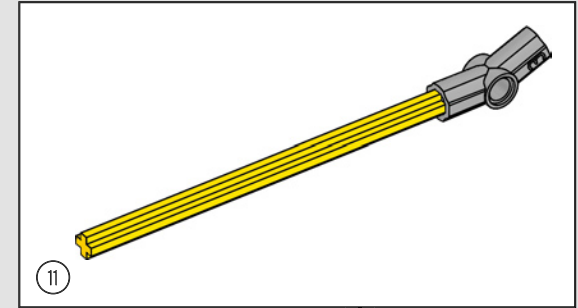



4x

639

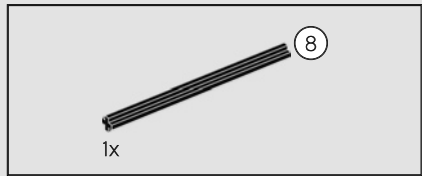
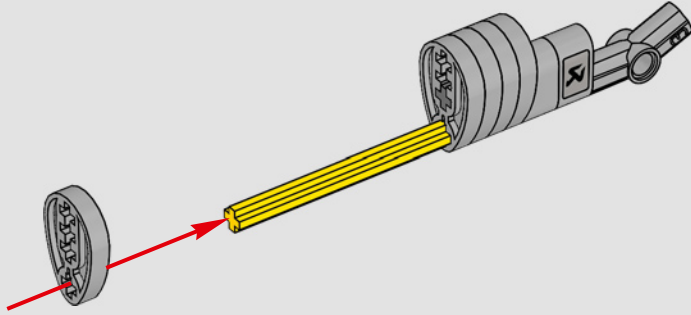

1x

640

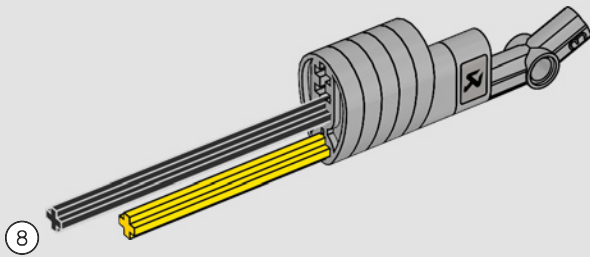

10x

641

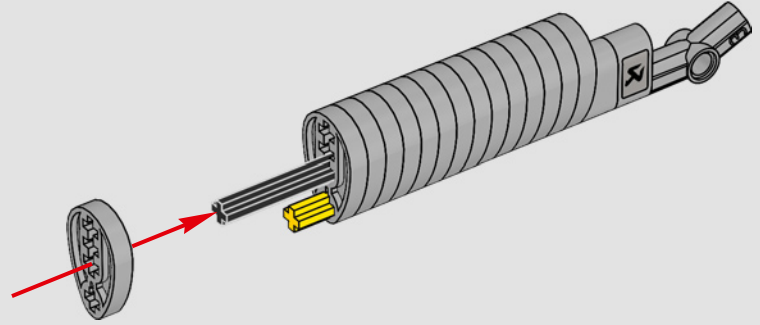

3x

642

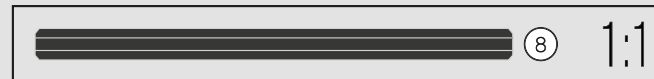
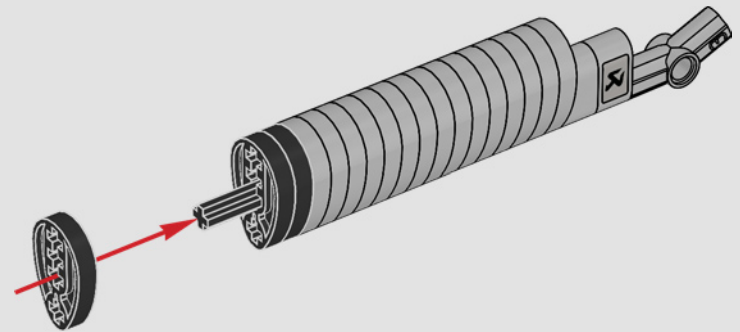

8

1:1

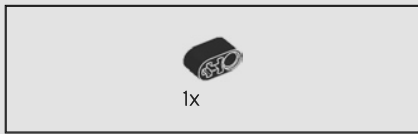

643

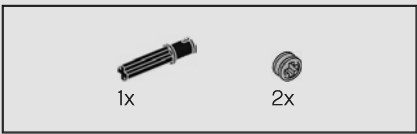
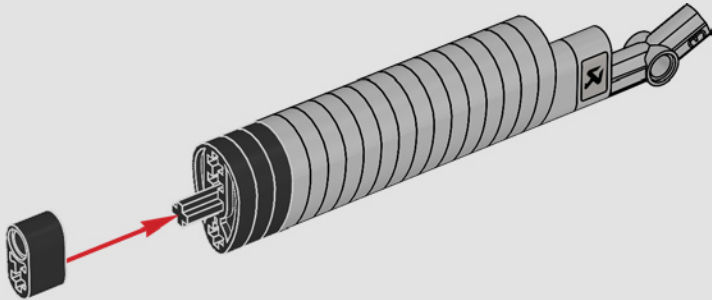

644

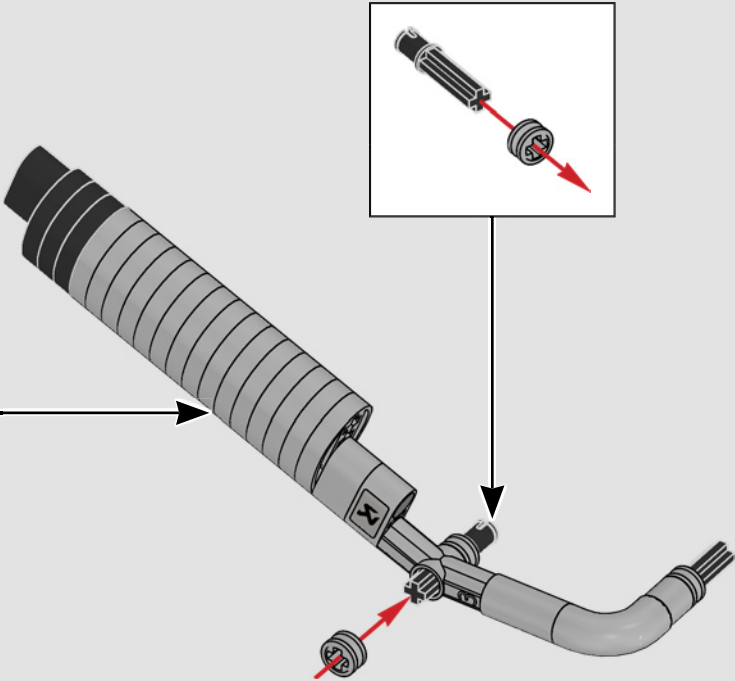

645

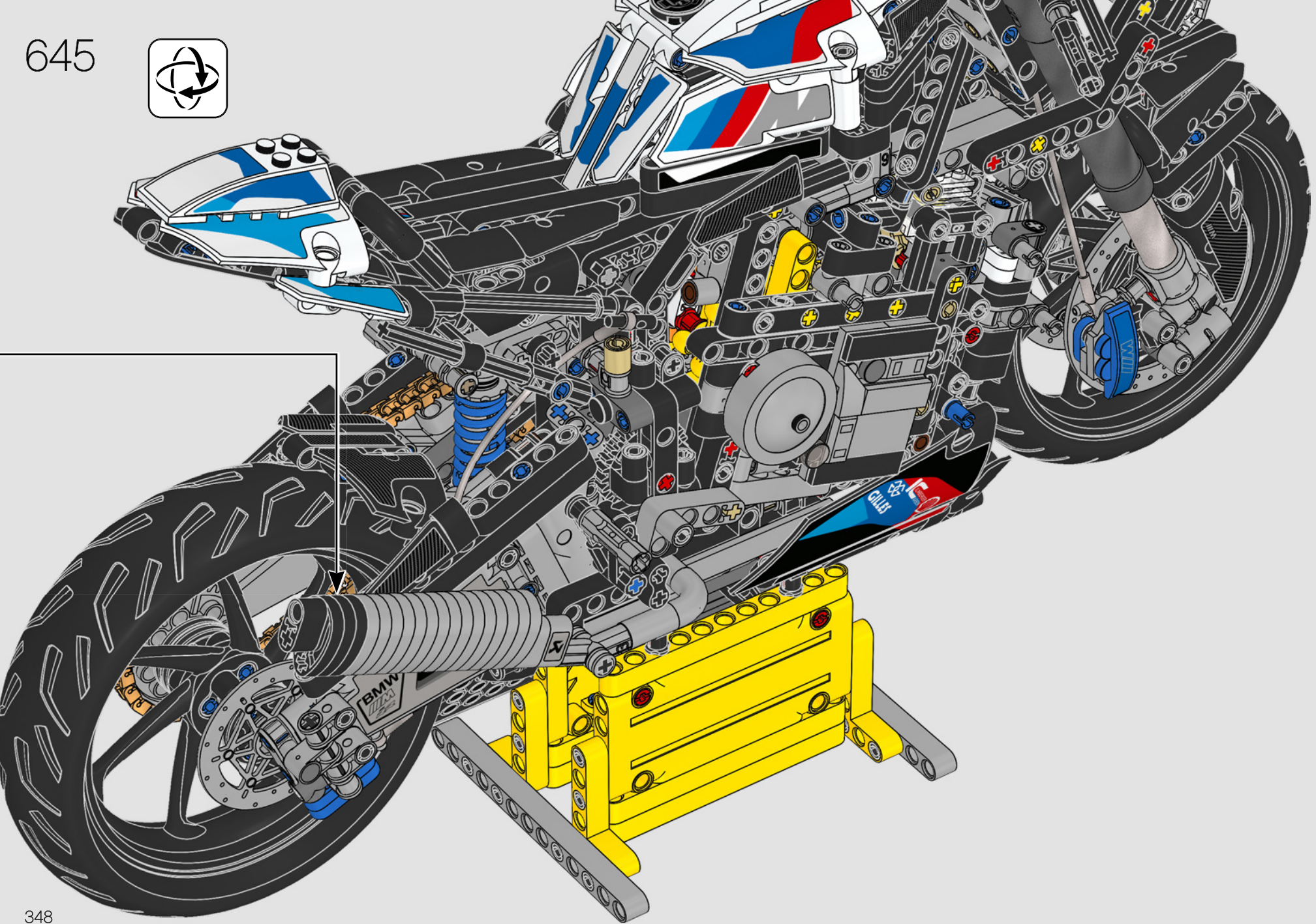

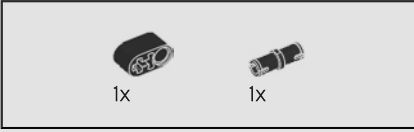
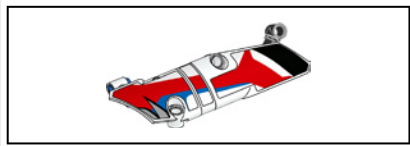

646

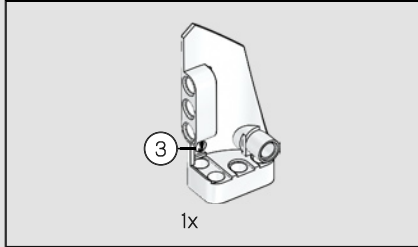
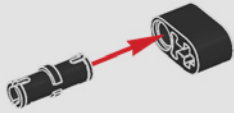

647

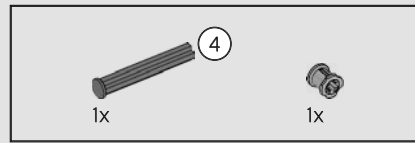
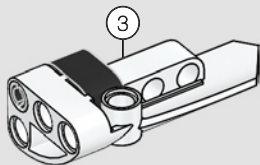

648

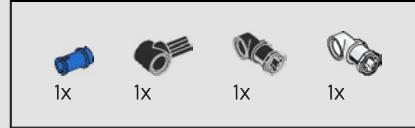
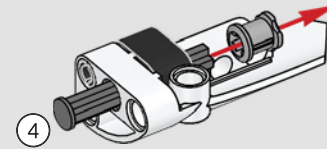

649

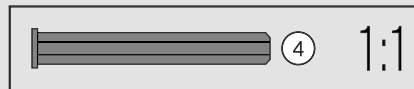
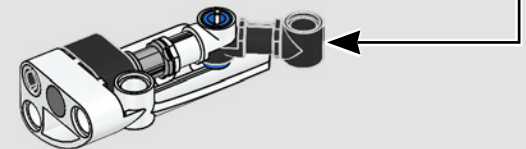
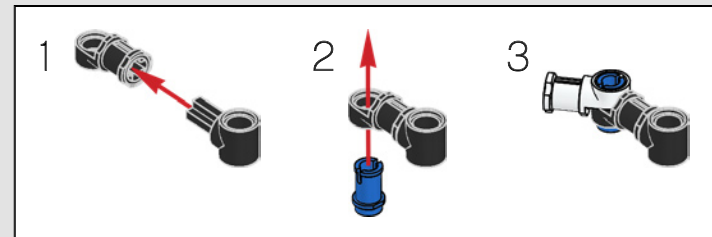

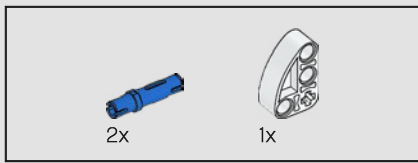

650

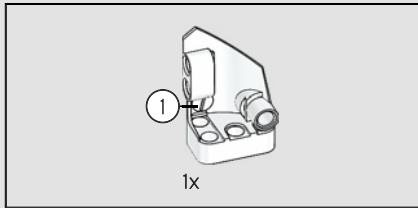
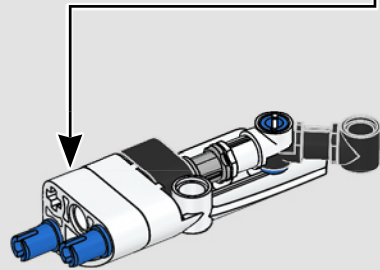
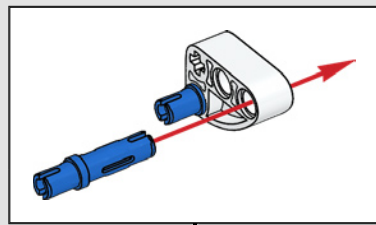

651

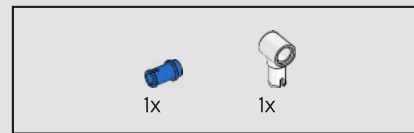
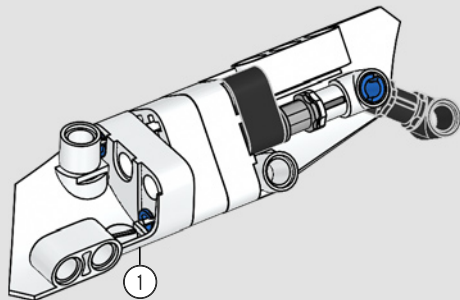

652

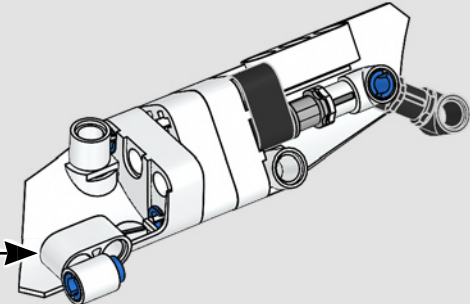
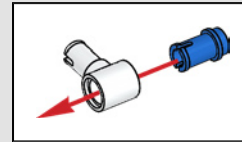

653

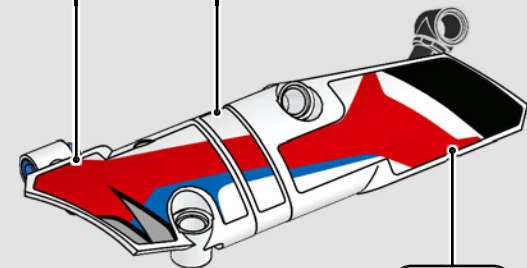
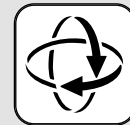

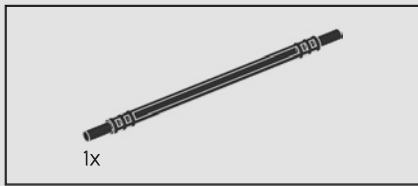

654

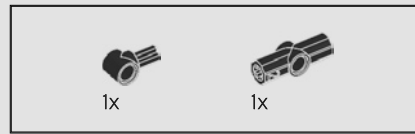
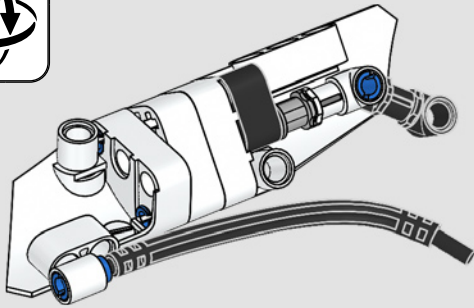

655

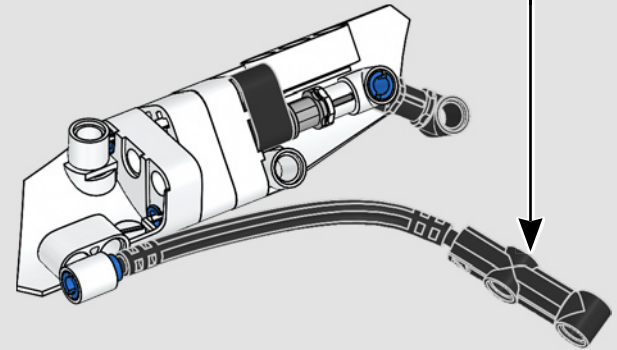
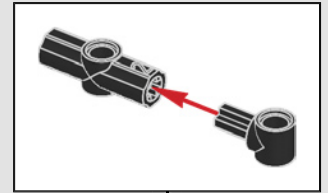

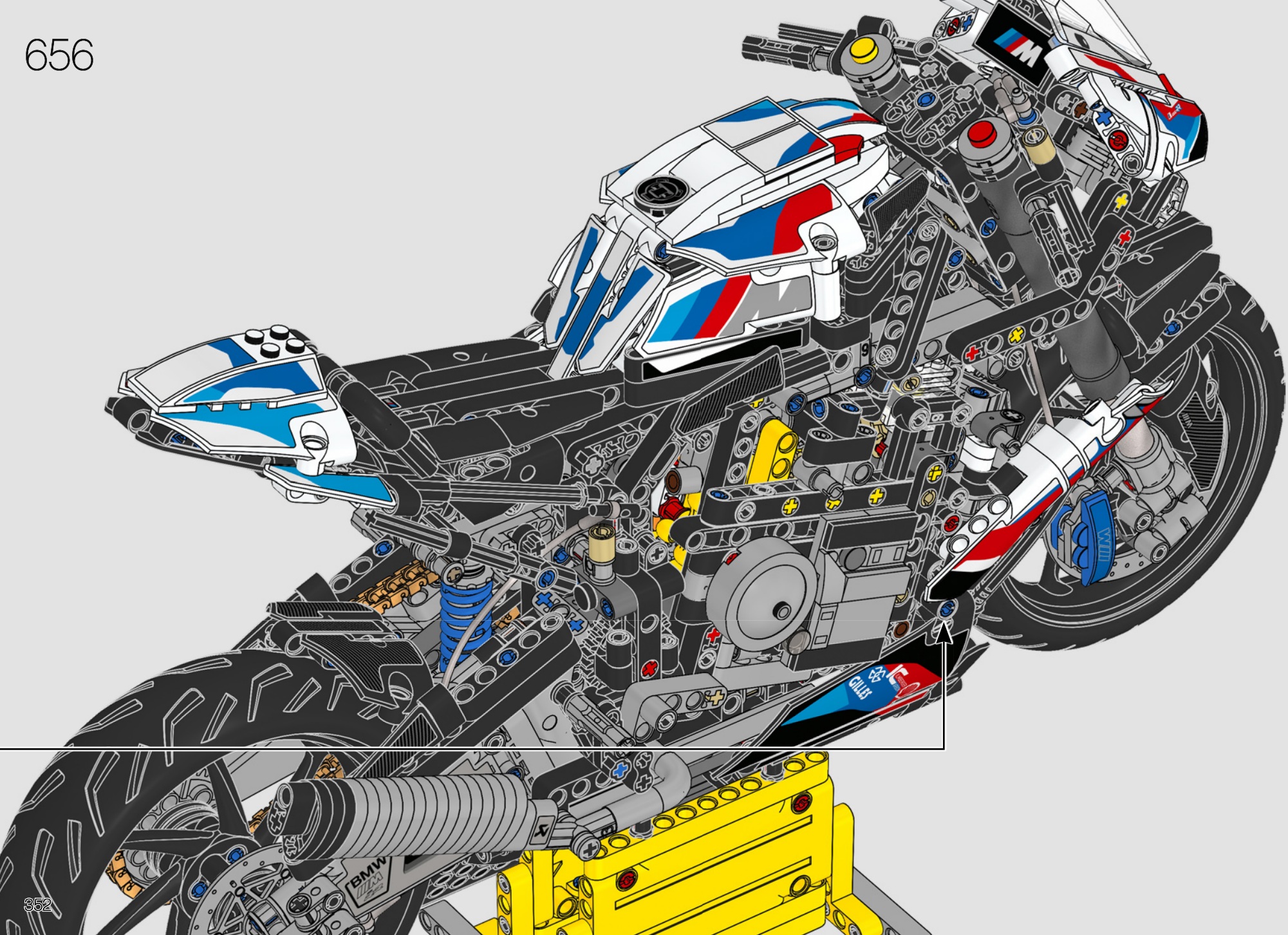

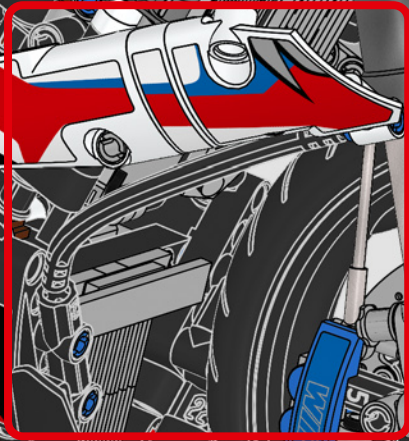
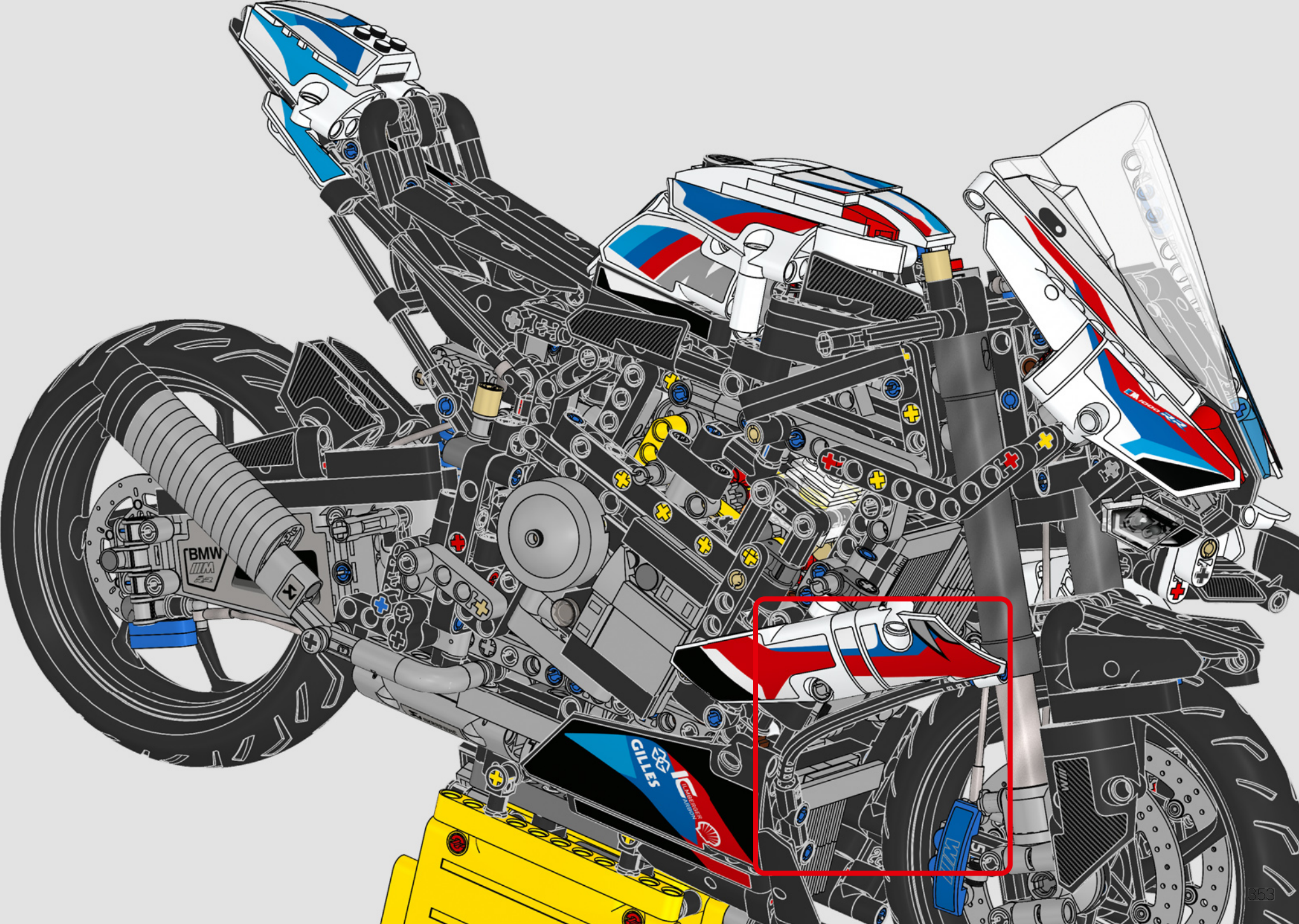

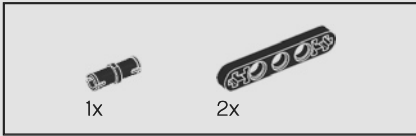
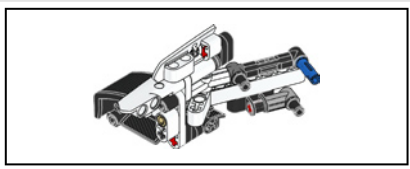

657

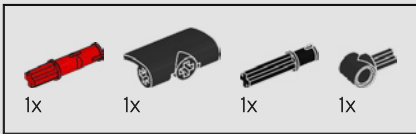
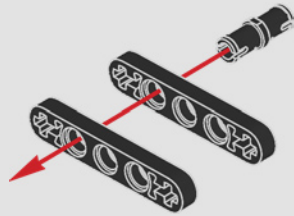

658

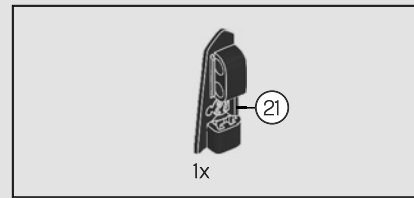
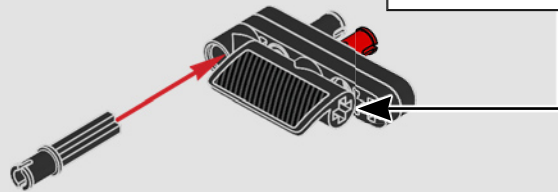
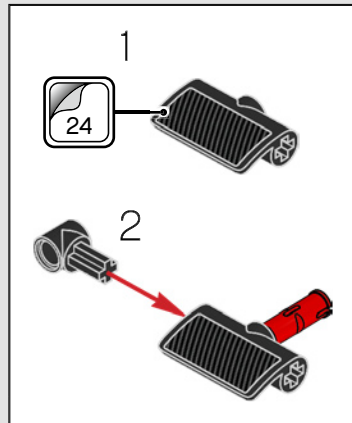

659

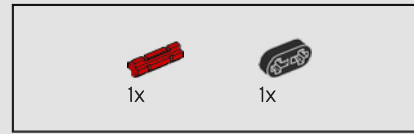
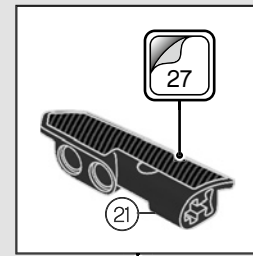

660

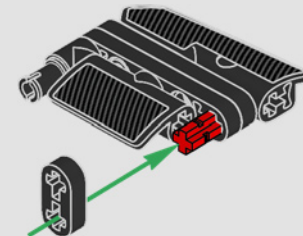

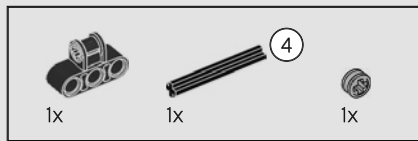

661

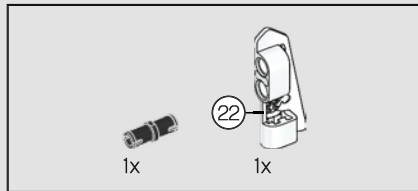
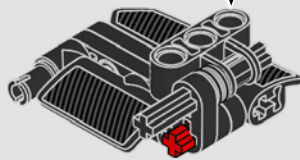
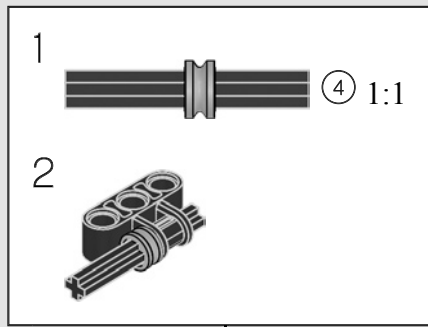

662

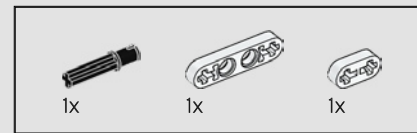
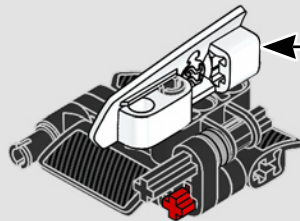
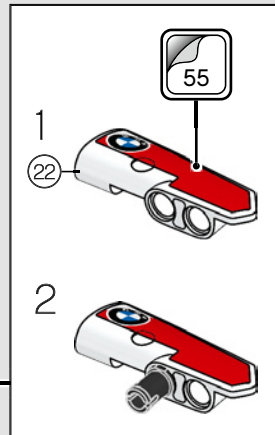

663

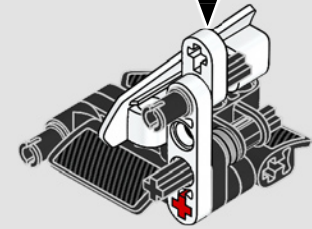
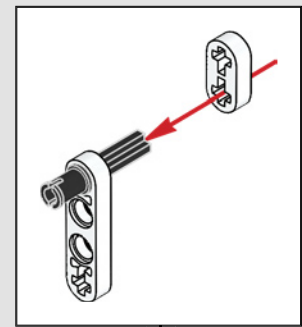

664

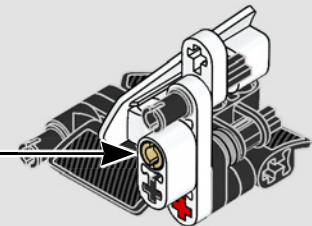
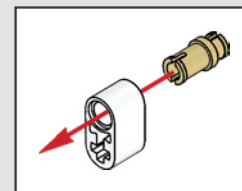

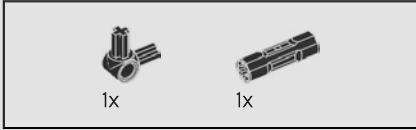
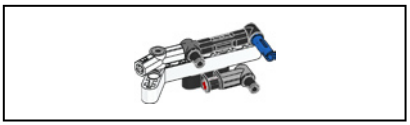

665

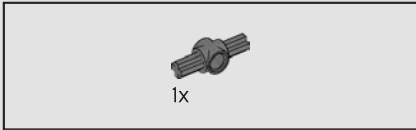
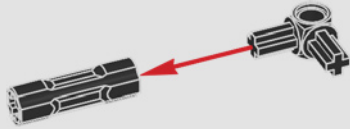

666

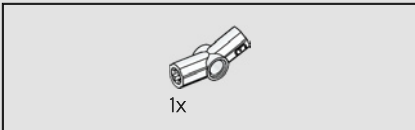
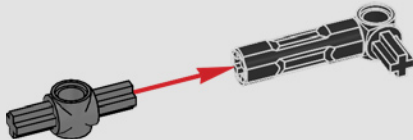

667

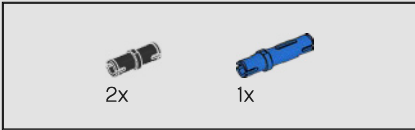

668

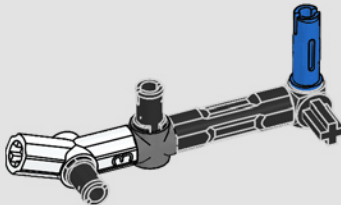

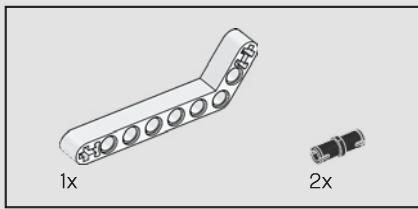

669

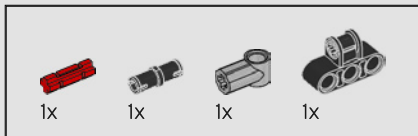
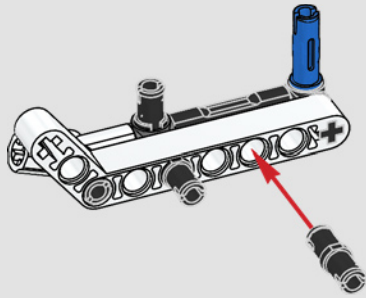

670

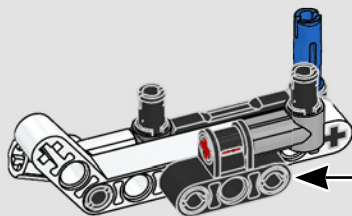
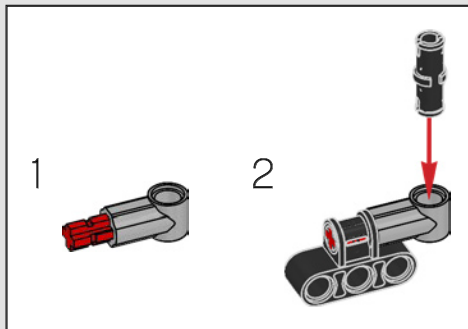

671

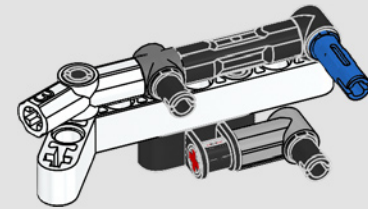

672

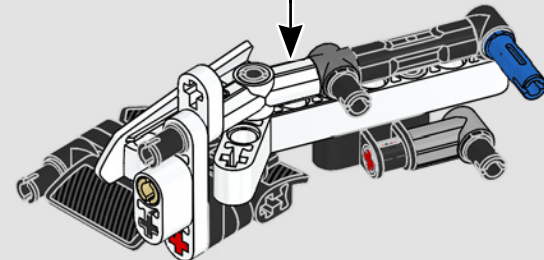

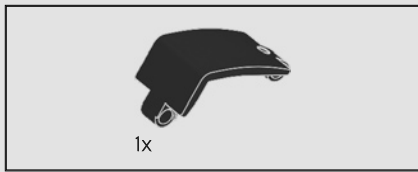

673

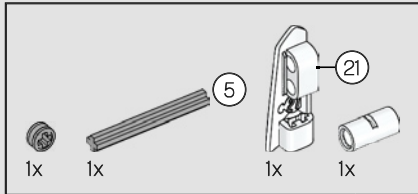
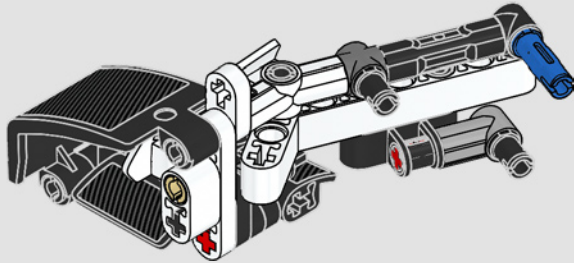
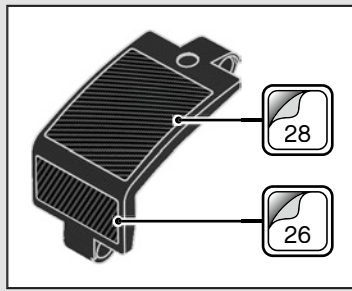

674

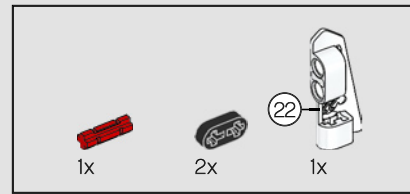
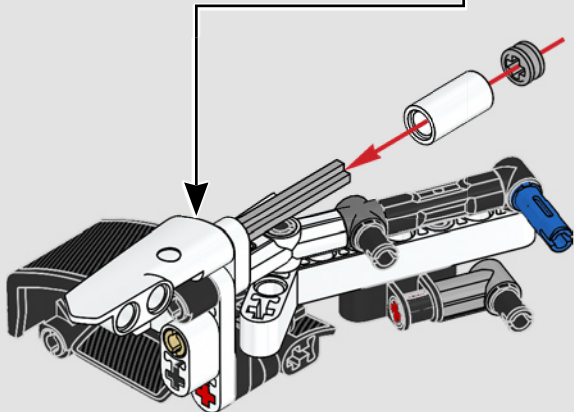
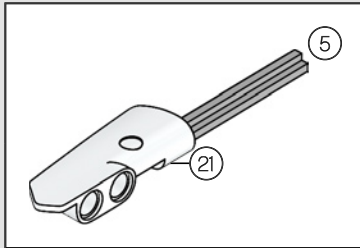

675

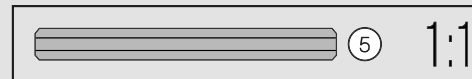
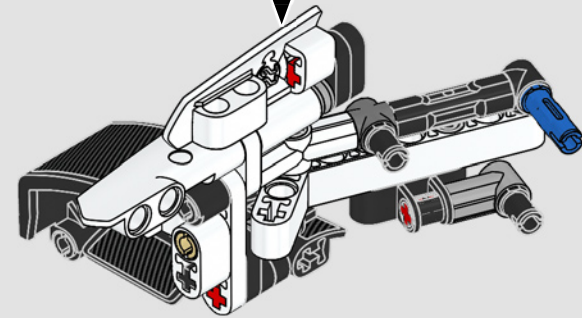
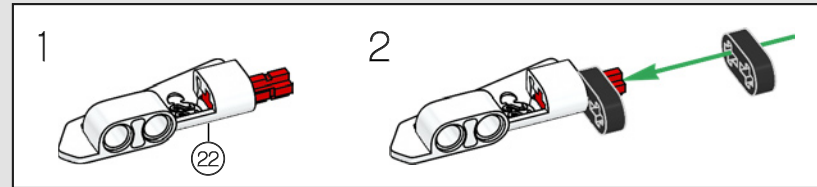

676

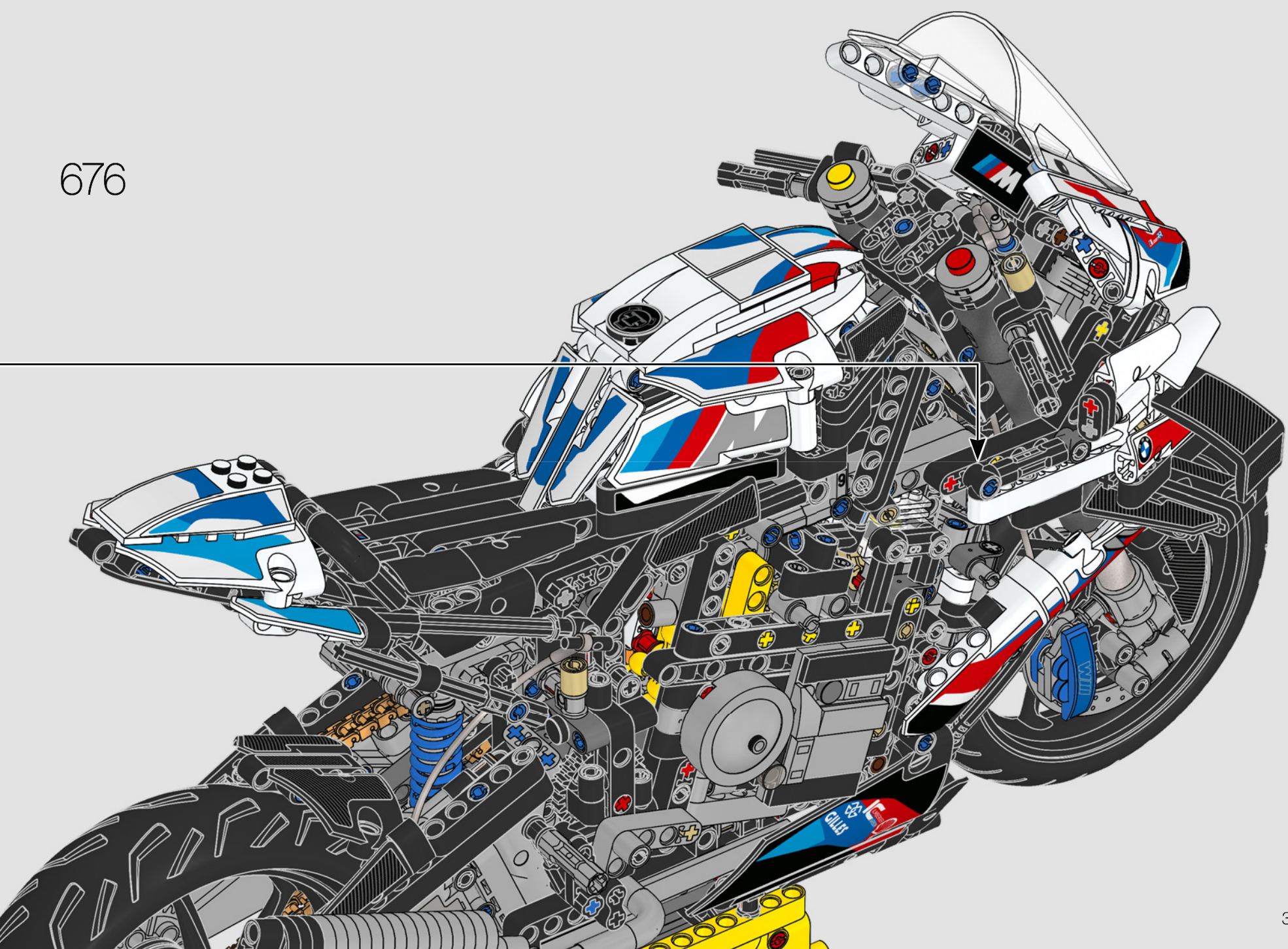

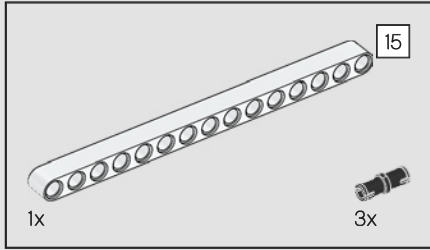
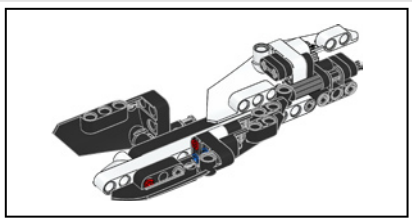

677

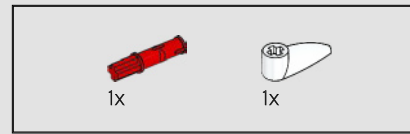
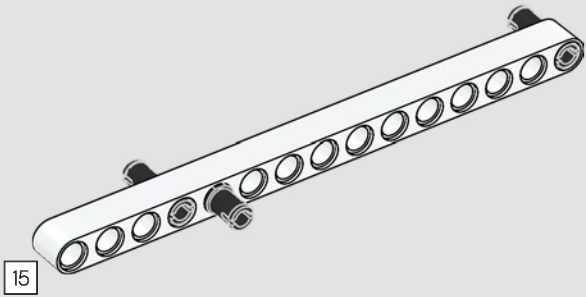

678

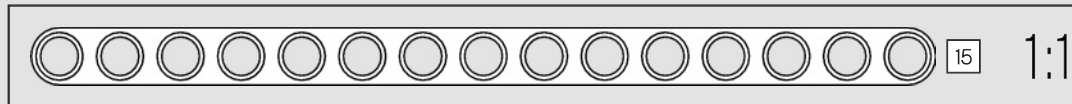
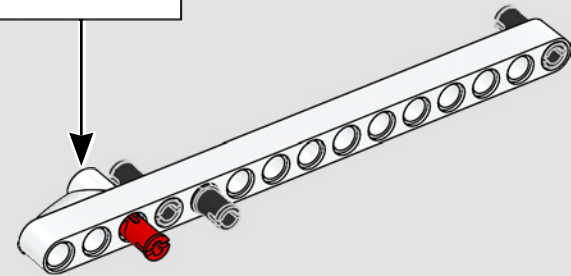
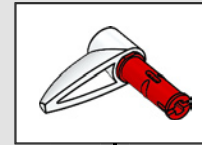

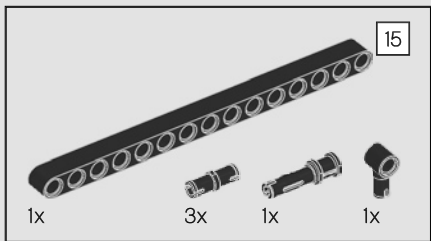

679

1

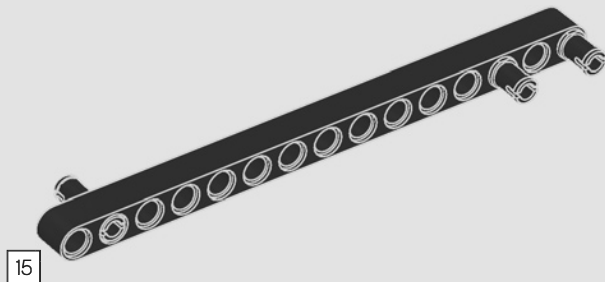

2

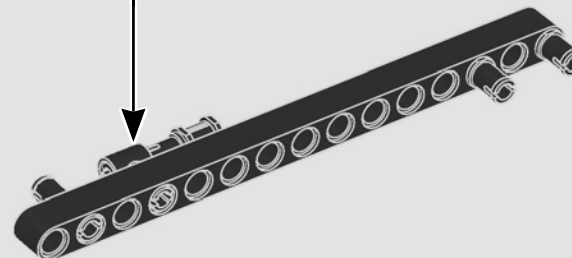

680

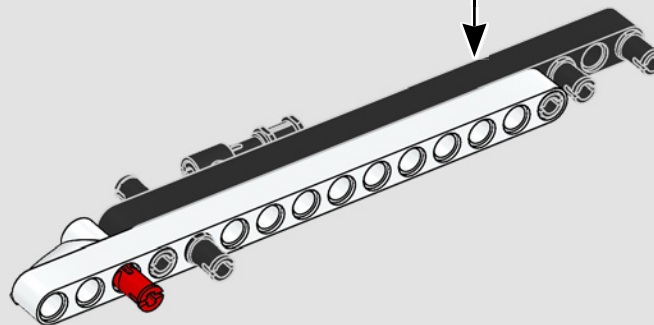

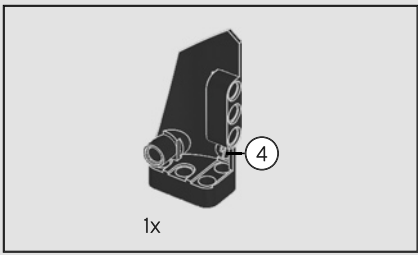

681

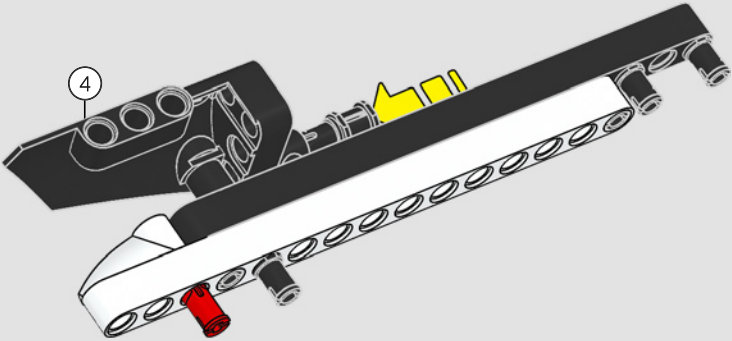

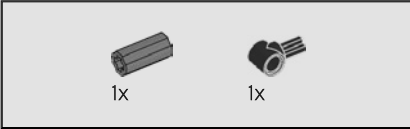
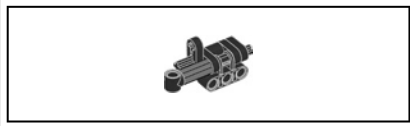

682

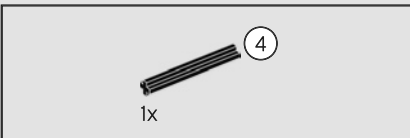
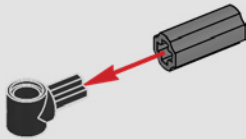

683

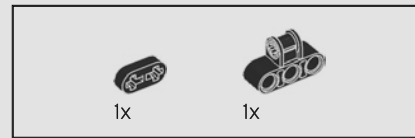
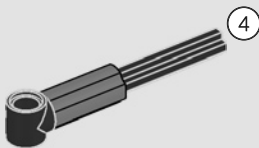

684

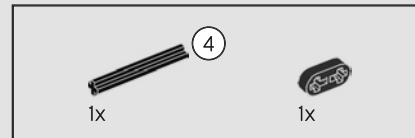
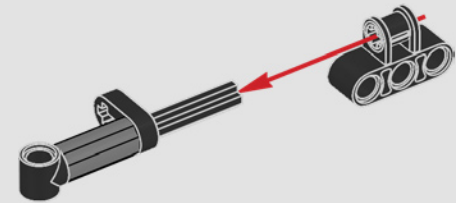

685

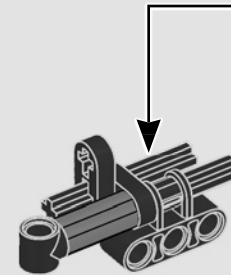



686

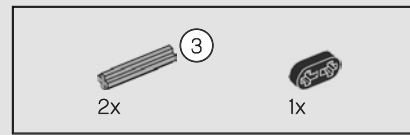
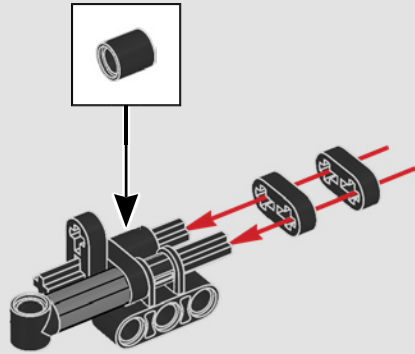

688

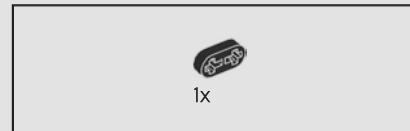
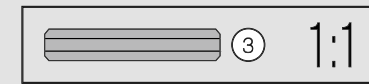
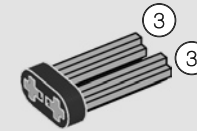

689

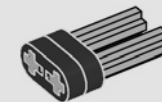

687

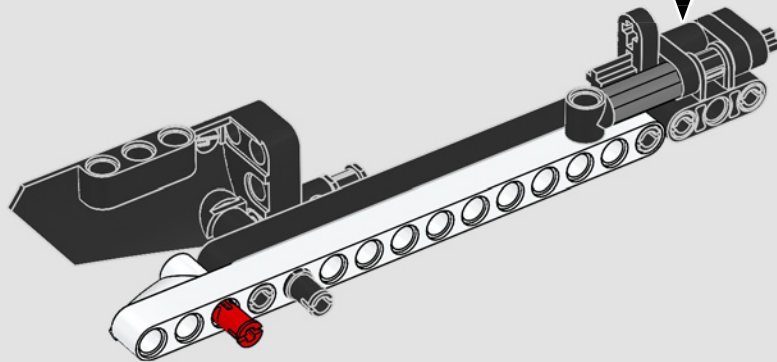

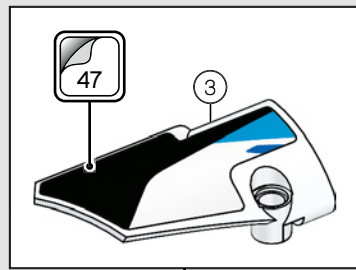
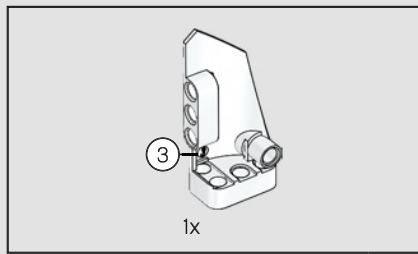

690

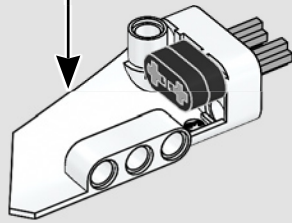

691

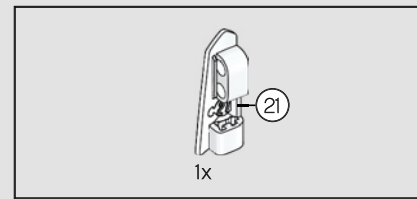
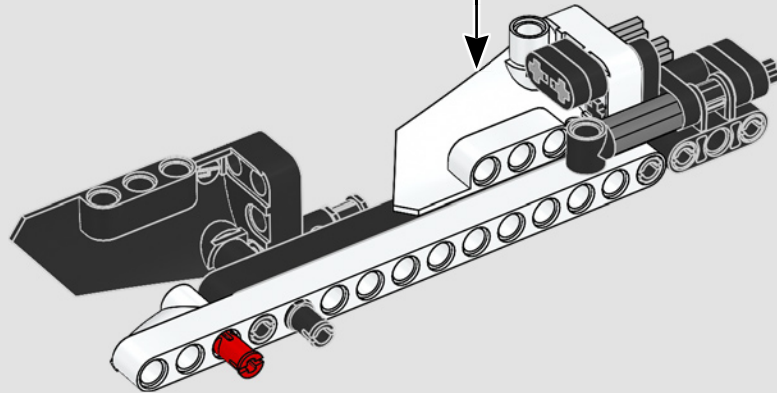

692

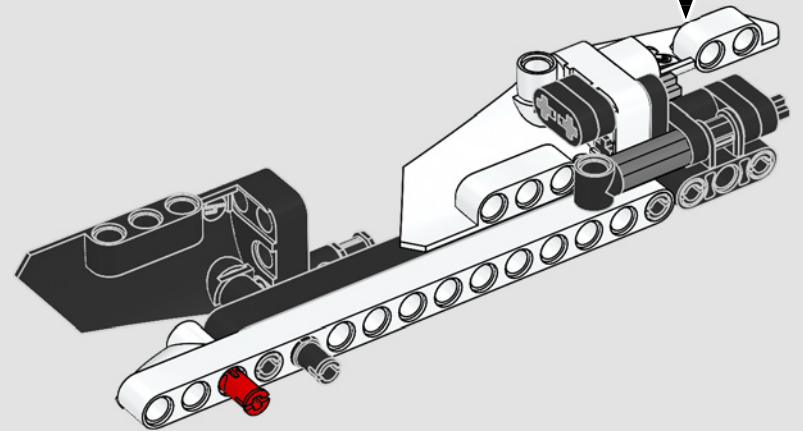
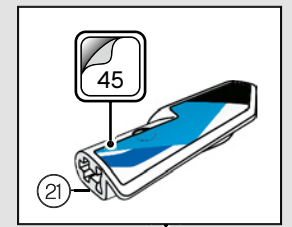

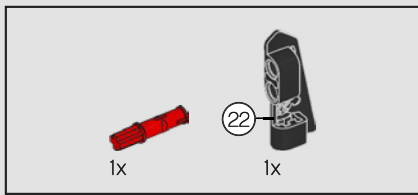

693

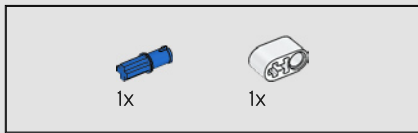
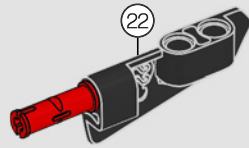

694

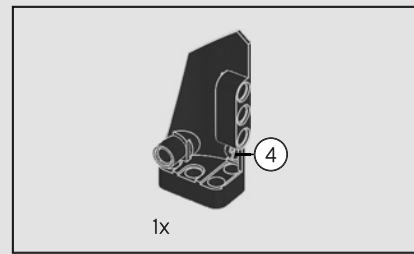
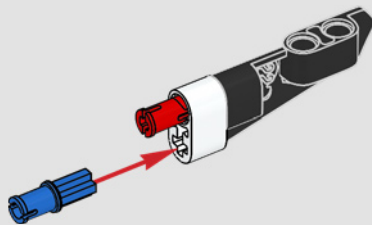

695

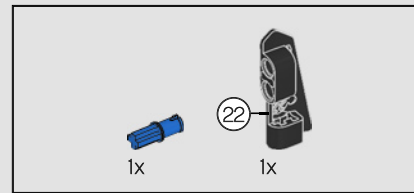
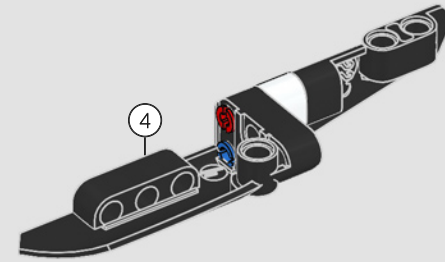

696

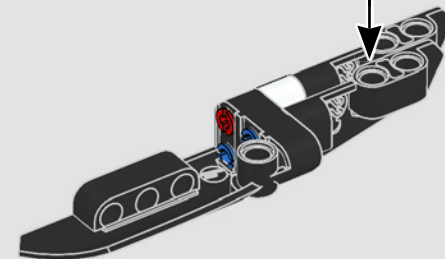
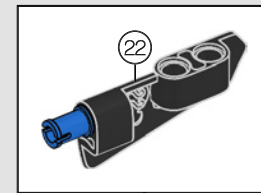

697

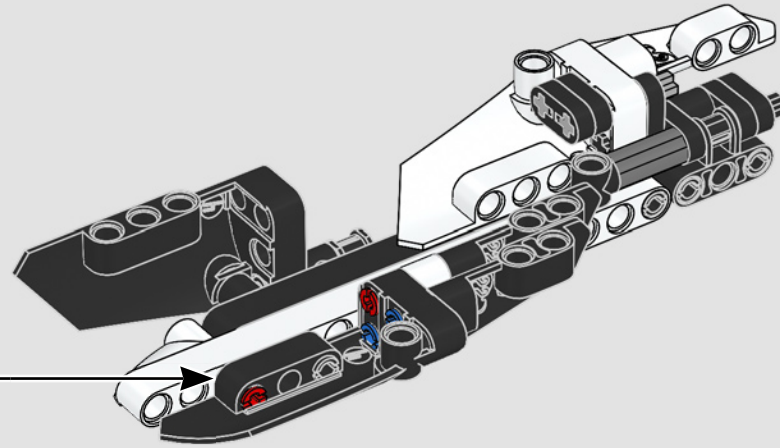

698

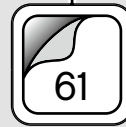
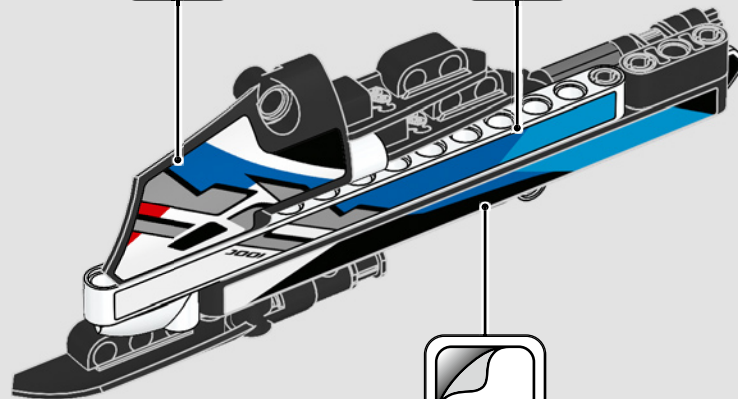

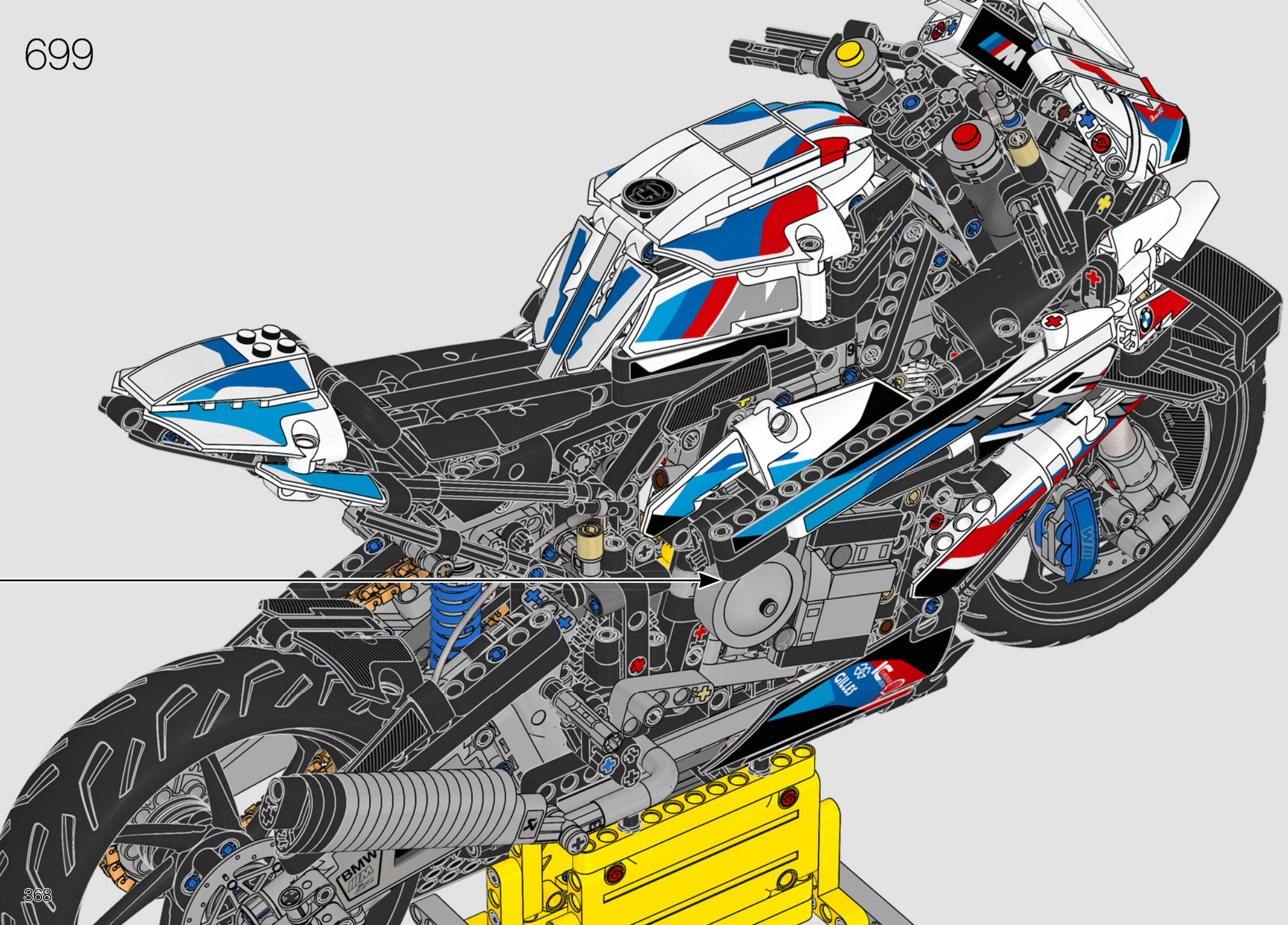

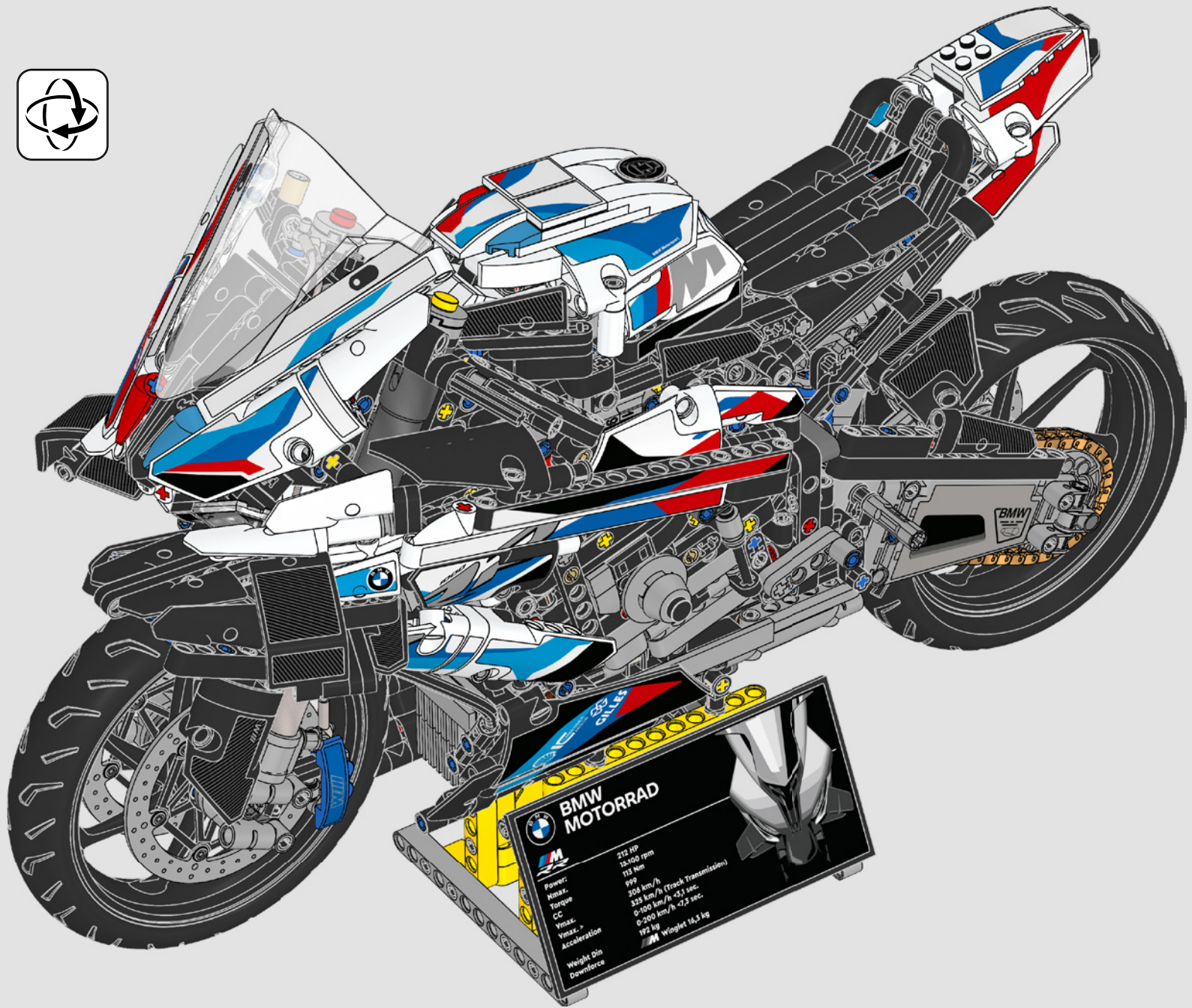

BMW MOTORRAD

Power:	212 HP
rpmax:	15.000 rpm
Torque:	113 Nm
CC	999
Vmax:	306 km/h (Track Transmission)
Acceleration	0-100 km/h < 3,1 sec.
Weight	0-200 km/h < 7,5 sec.
Downforce	192 kg
	Winglet 16,3 kg

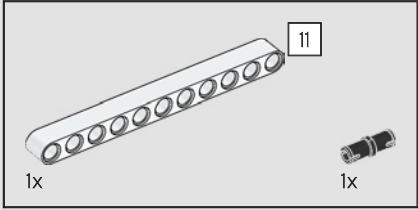
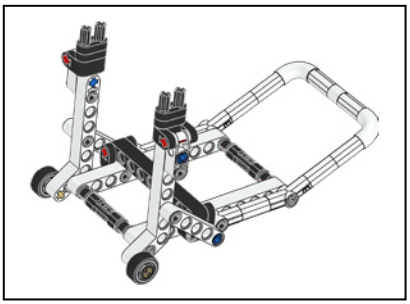

1

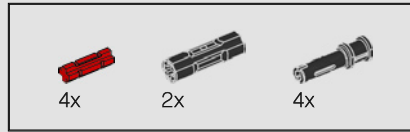
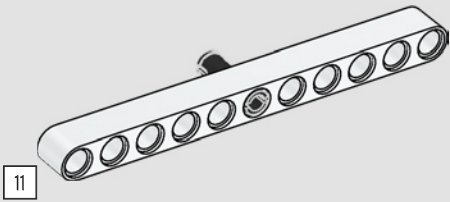

2

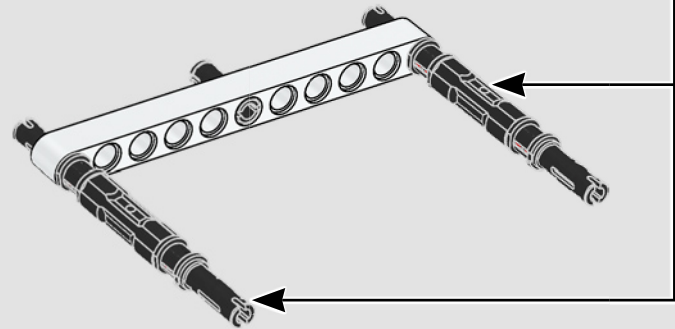
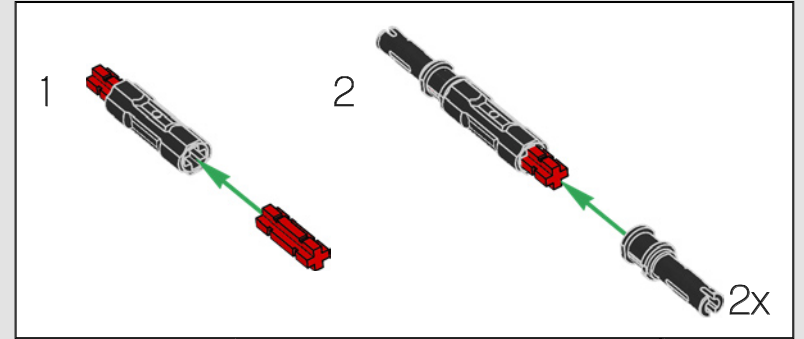

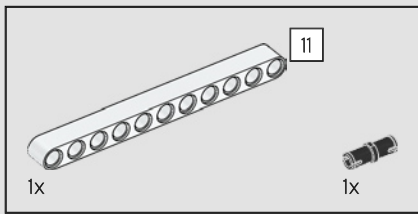

3

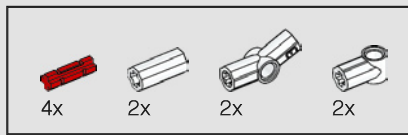
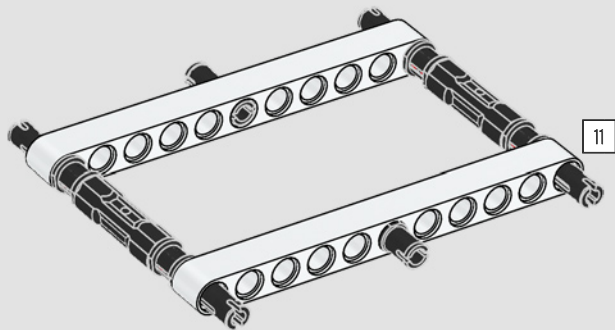

4

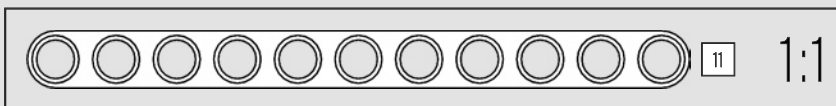
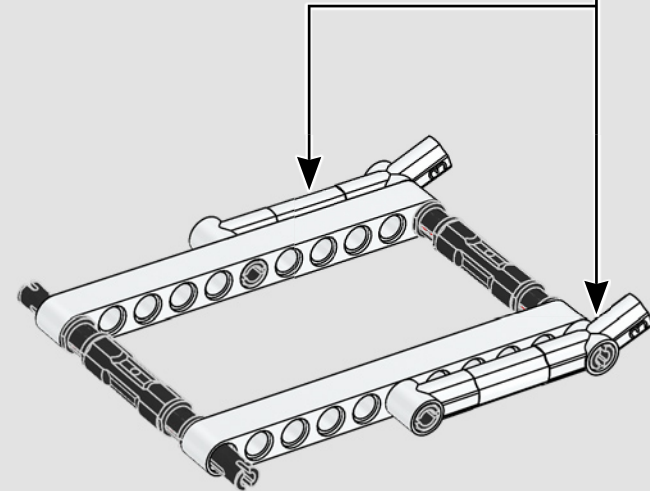
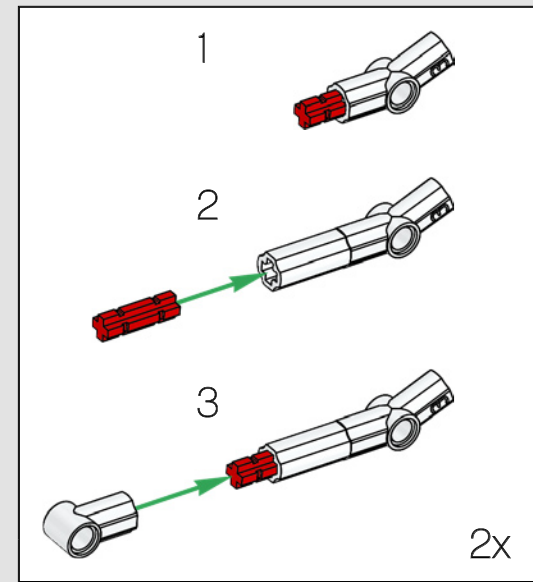

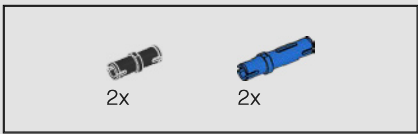

5

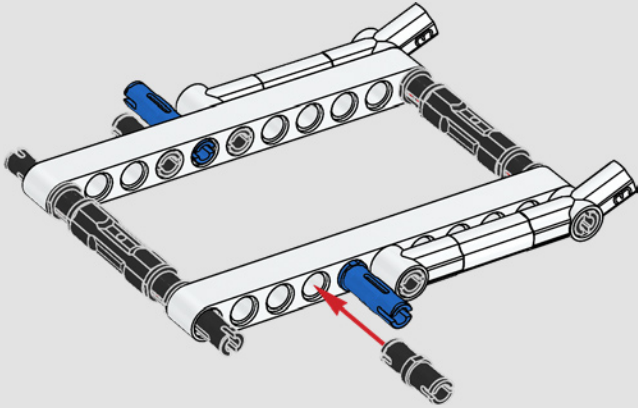

6

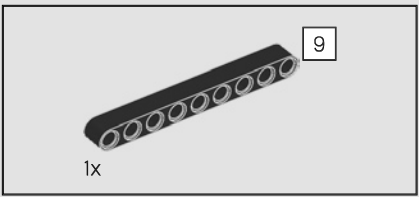
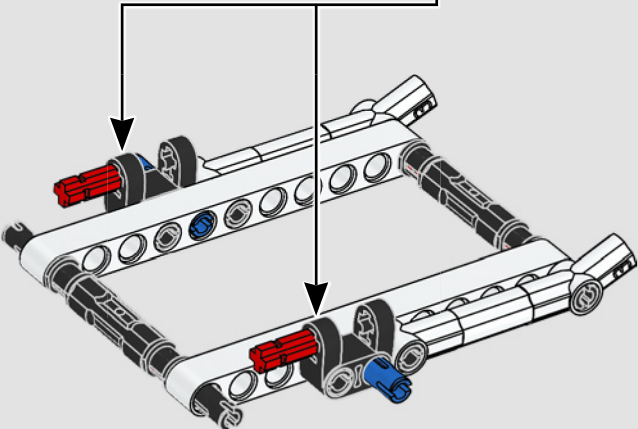

7

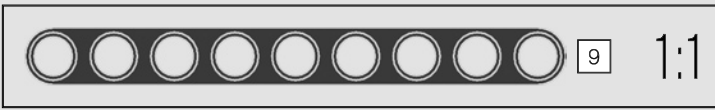
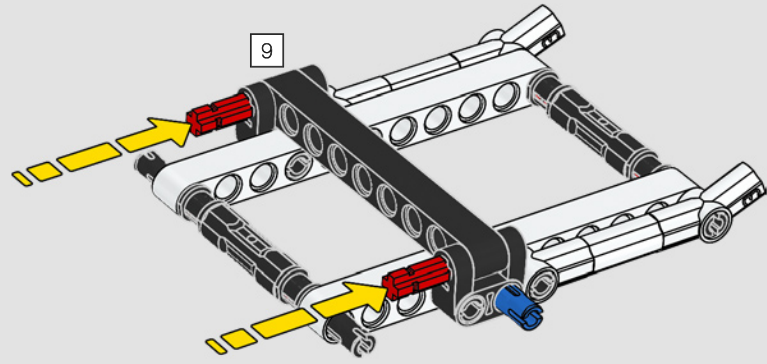

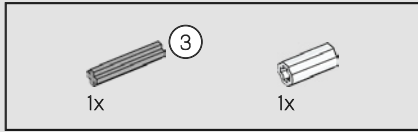
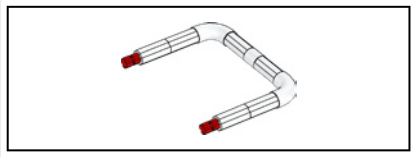

8

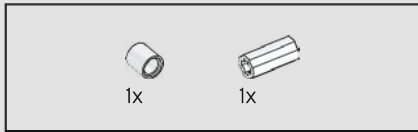
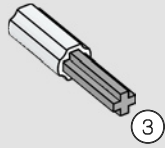

9

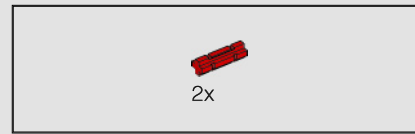
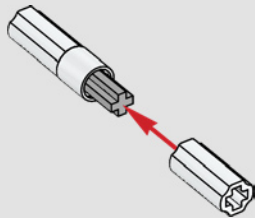

10

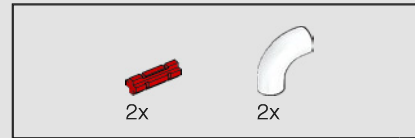
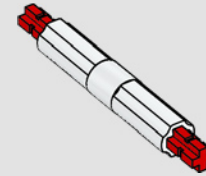

11

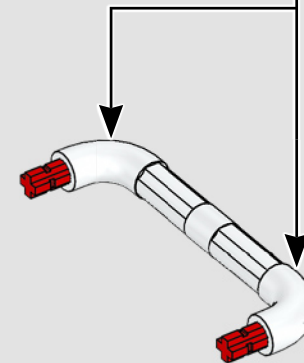
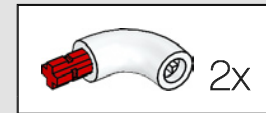

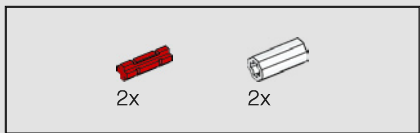

12

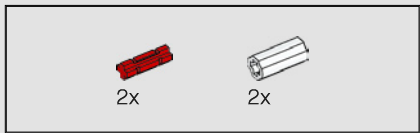
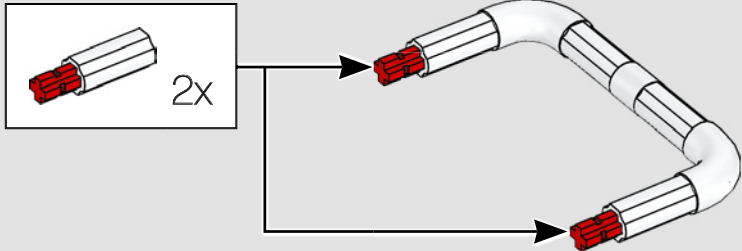

13

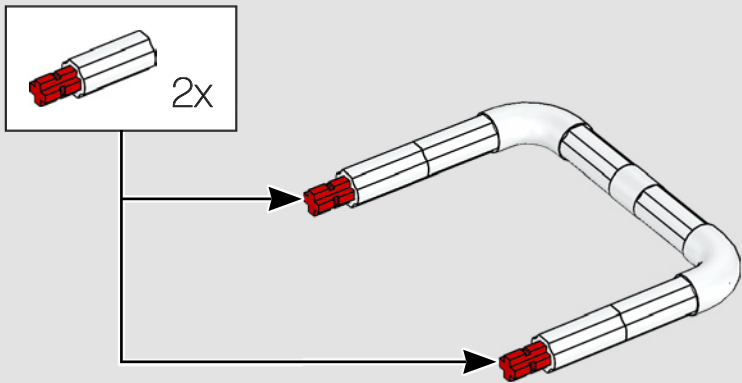

14

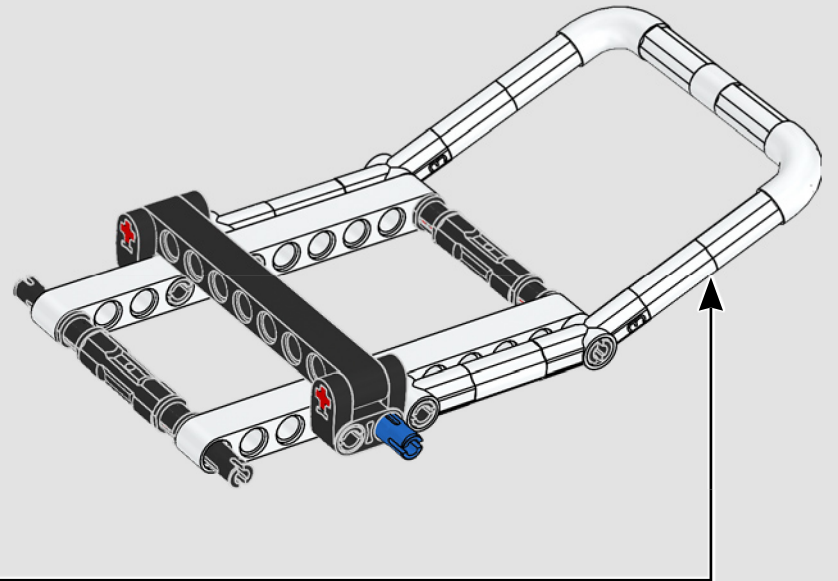

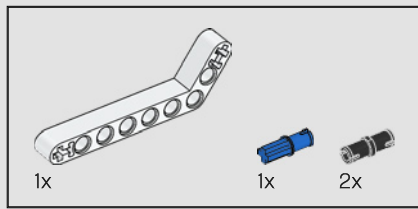

15

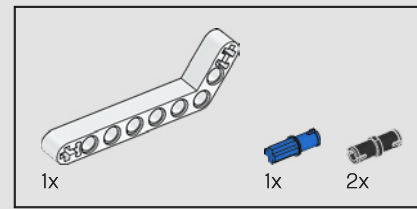
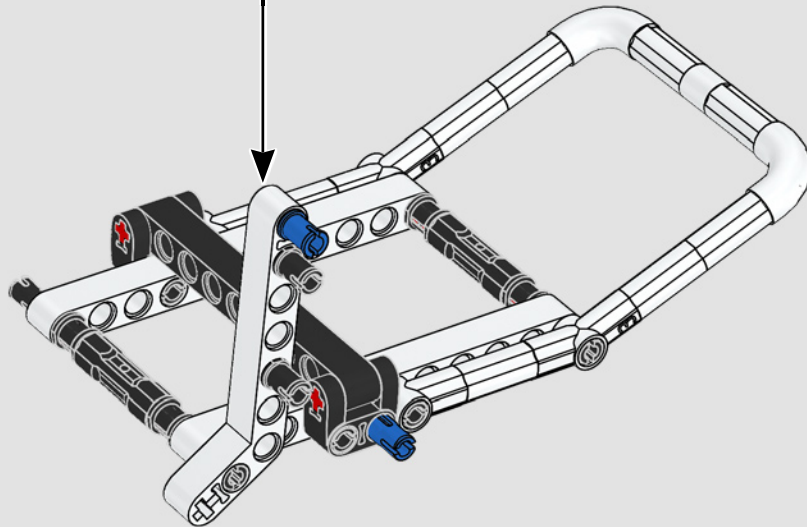
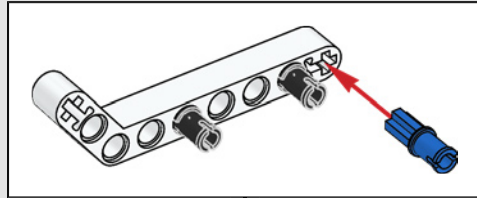

16

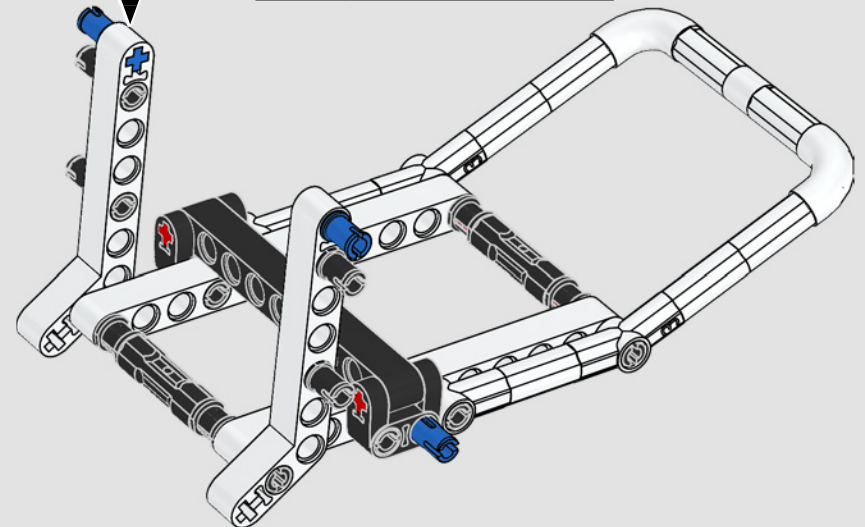
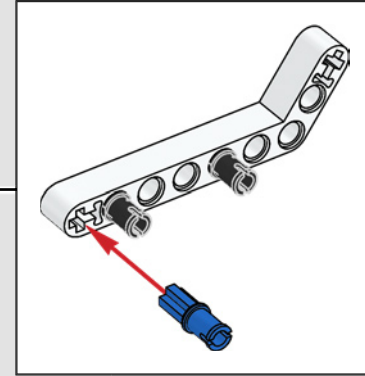

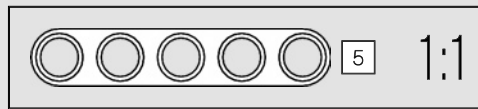
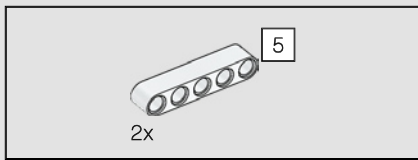

17

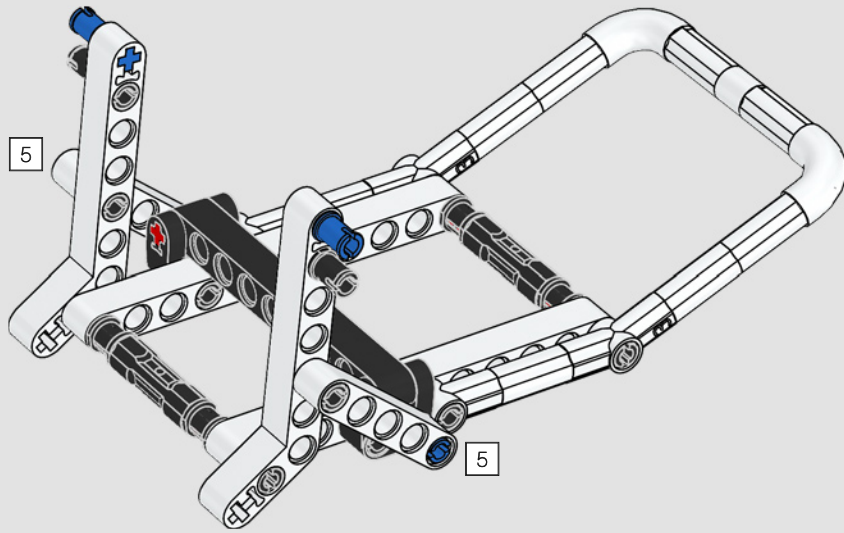

18

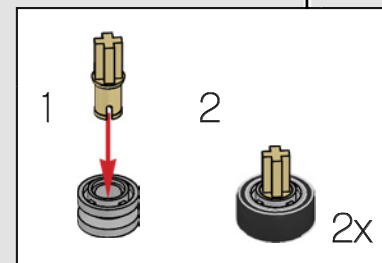
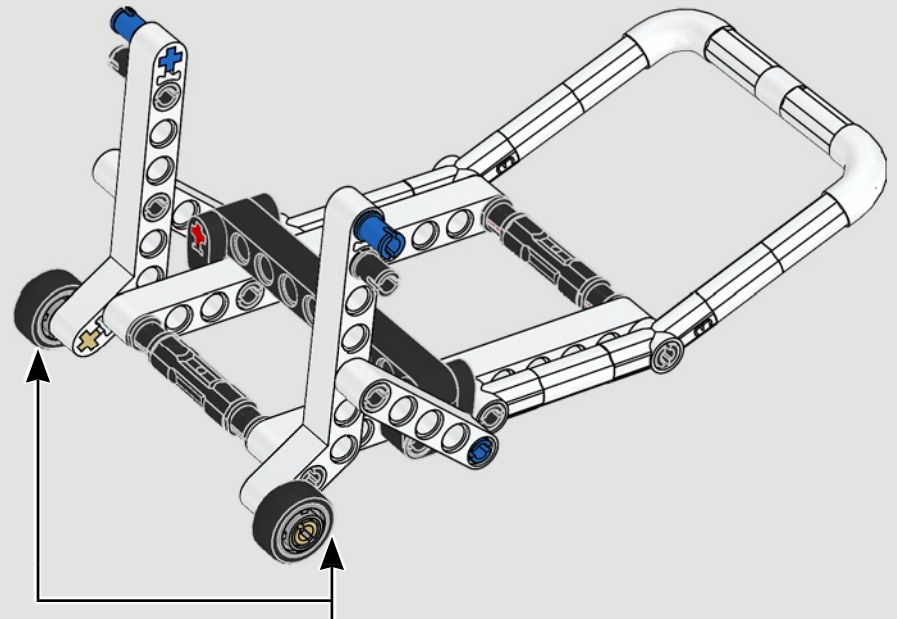

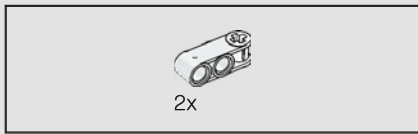

19

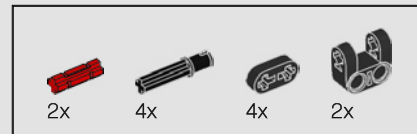
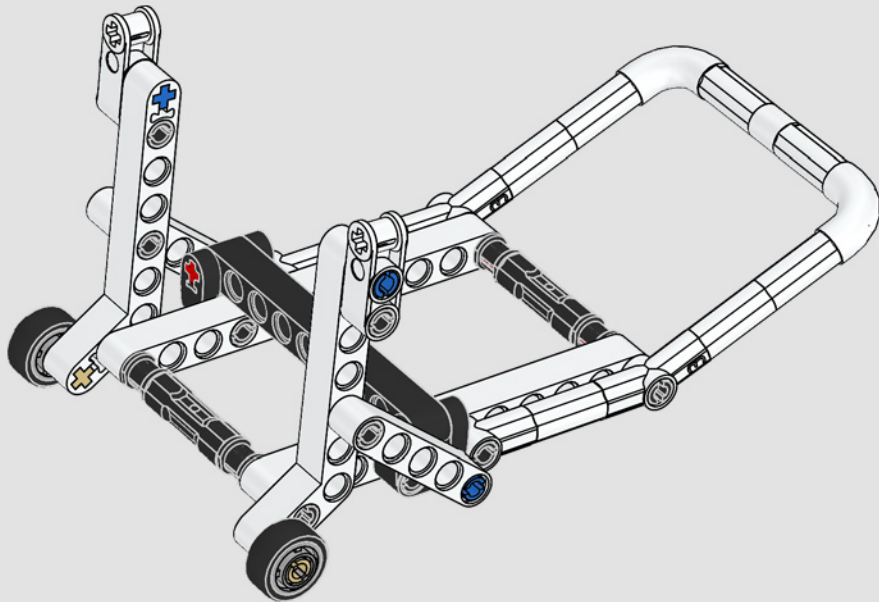

20

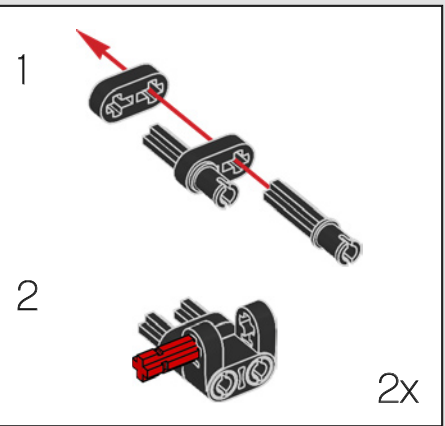
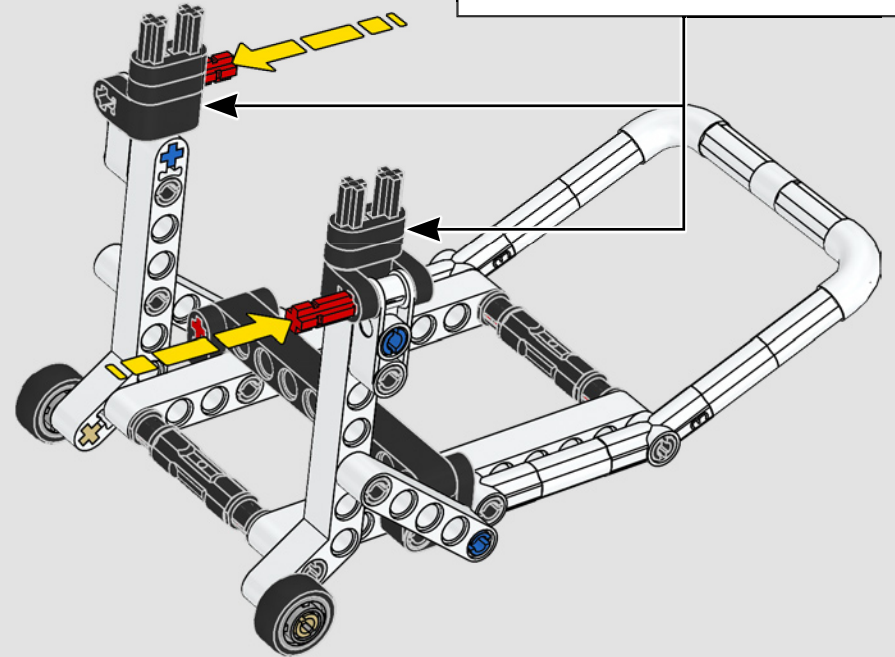

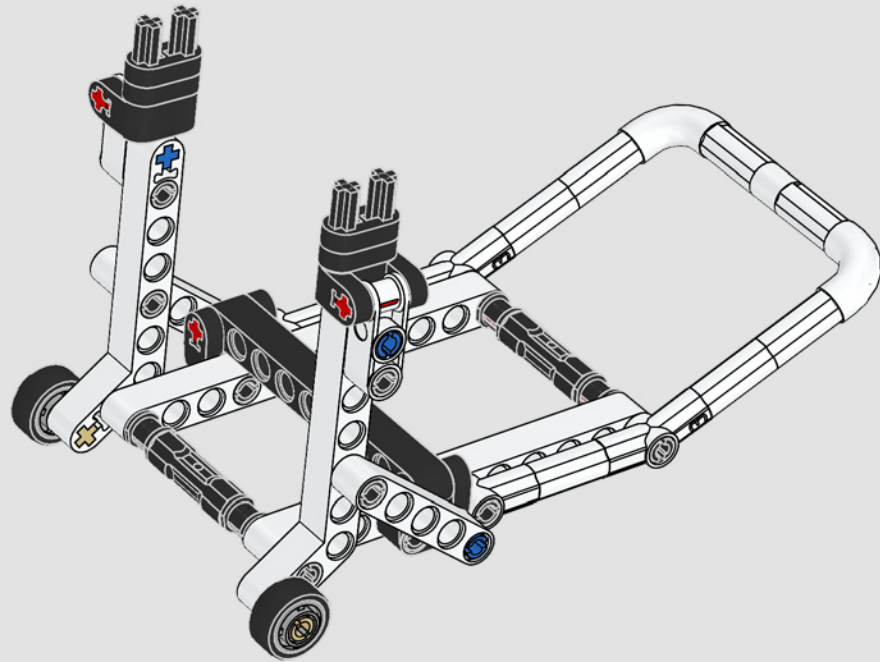

700

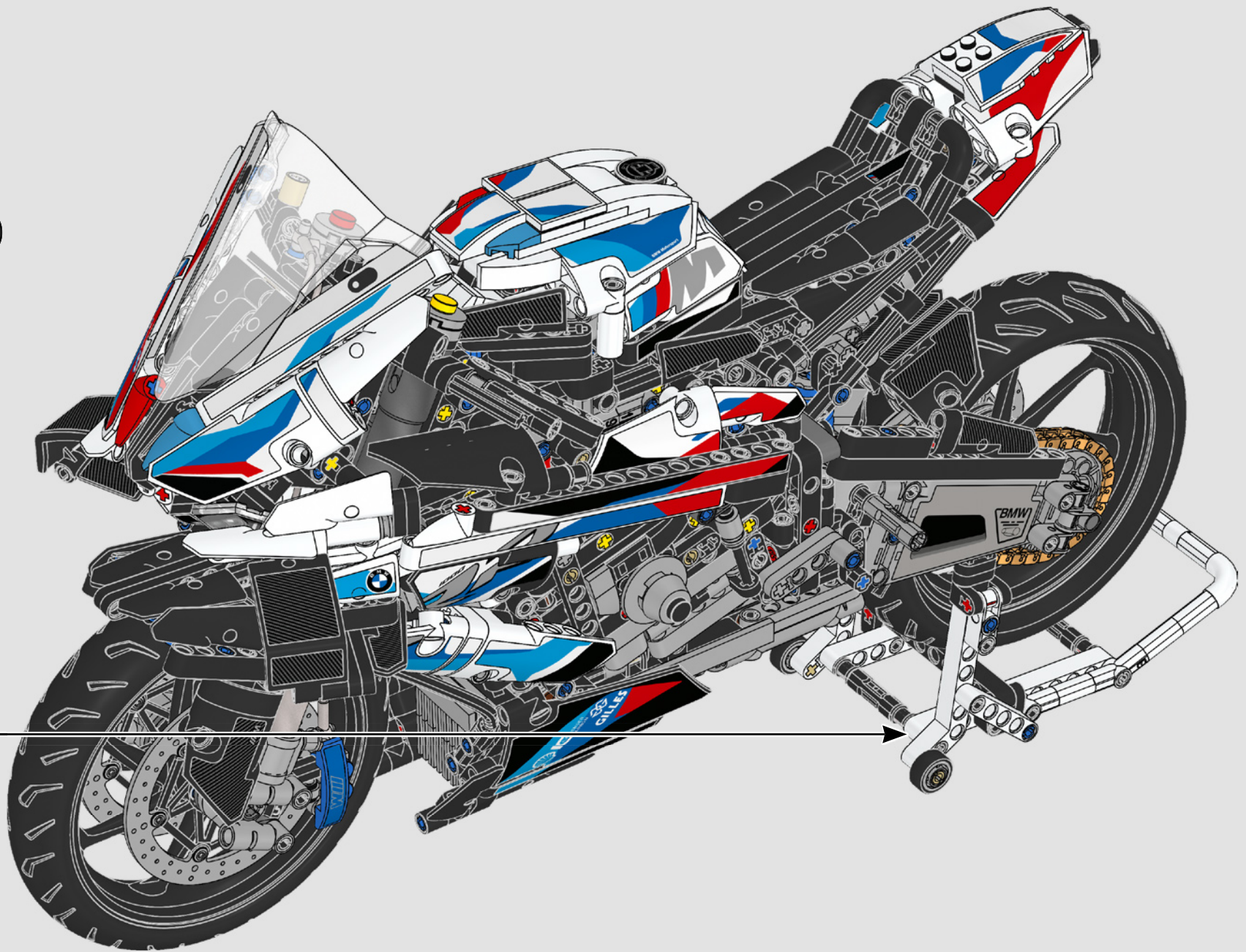

- 1x 6177114
- 2x 6282148
- 2x 4544140
- 7x 6343987
- 10x 6371416
- 2x 6323918
- 7x 6330084
- 2x 6332573
- 2x 6194851
- 2x 6179606
- 7x 6265135
- 4x 6345327
- 8x 6212049
- 2x 3200001
- 6x 6173116
- 3x 6034044
- 2x 6271349
- 2x 6288218
- 2x 6330960
- 1x 6047220
- 4x 6261390
- 2x 6271870
- 2x 4249112
- 1x 362301
- 2x 4249021
- 2x 366601
- 1x 4558874
- 1x 4558878
- 2x 6360072
- 6x 4547582
- 2x 302101
- 1x 6132212
- 2x 6156667
- 6x 4547581
- 2x 6045936
- 2x 302001
- 2x 4249021
- 2x 366601
- 1x 4179869
- 5x 6276842
- 4
- 3
- 5
- 2
- 1

- 1x 303401
- 4x 6001831
- 4x 6028103
- 2x 4542578
- 3x 6167923
- 15x 6013938
- 3x 6355727
- 5x 4666579
- 2x 6346517
- 1x 6321305
- 2x 4666999
- 1x 6284574
- 13x 6271820
- 4x 6360104
- 9
- 11
- 15

- 1x 6177507
- 62x 4142865
- 2x 6167939
- 7x 6100930
- 1x 4179355
- 1x 6285599
- 1x 6273712
- 37x 6209519
- 5x 6347789
- 3x 6273211
- 4x 6129995
- 1x 4142132
- 1x 6130002
- 2x 6130004
- 4x 6284575
- 37x 4143005
- 1x 617507
- 2x 4142865
- 2x 6167939
- 7x 6100930
- 1x 4179355
- 1x 6285599
- 1x 6273712
- 37x 6209519
- 5x 6347789
- 3x 6273211
- 4x 6129995
- 1x 4142132
- 1x 6130002
- 2x 6130004
- 4x 6284575
- 37x 4143005

- 2x 6315482
- 69x 4206482
- 1x 6224999
- 2x 6344176
- 132x 6299413
- 2x 4649773
- 1x 6284577
- 4x 4112203
- 1x 403224
- 2x 4187122
- 2x 4119474
- 3x 6284189
- 7x 6130008
- 10x 4144022
- 7
- 7
- 9
- 11
- 11
- 6x 6028107
- 7x 6130012
- 2x 6311003
- 1x 6170421
- 3x 6284070
- 3x 6168646
- 17x 6121485
- 23x 6282140
- 1x 6181720

- 2x 4177431
- 14x 6319983
- 2x 6196548
- 1x 6181713
- 3x 4143187
- 2x 4246901
- 43x 6338428
- 6x 6322045
- 4x 6261371
- 12x 6316923
- 6x 6284699
- 207x 6279875
- 2x 403226
- 4x 6179182
- 1x 6070695
- 16x 6253260
- 8x 6099801
- 34x 6265091
- 10x 6326047
- 8x 4512363
- 4x 6280394
- 6x 6331716
- 10x 6349281
- 2x 6268905
- 1x 6174243
- 1x 6047276
- 1x 6156991
- 2x 6147050
- 4x 6271346
- 3x 6325521

- 8x 6313520
- 2x 6262897
- 10x 6271810
- 4x 6323668
- 3x 6273708
- 2x 242026
- 2x 4124096
- 25x 6089119
- 27x 6321745
- 4x 4107765
- 4x 6261386
- 1x 6276951
- 3x 4552347
- 2x 4142822

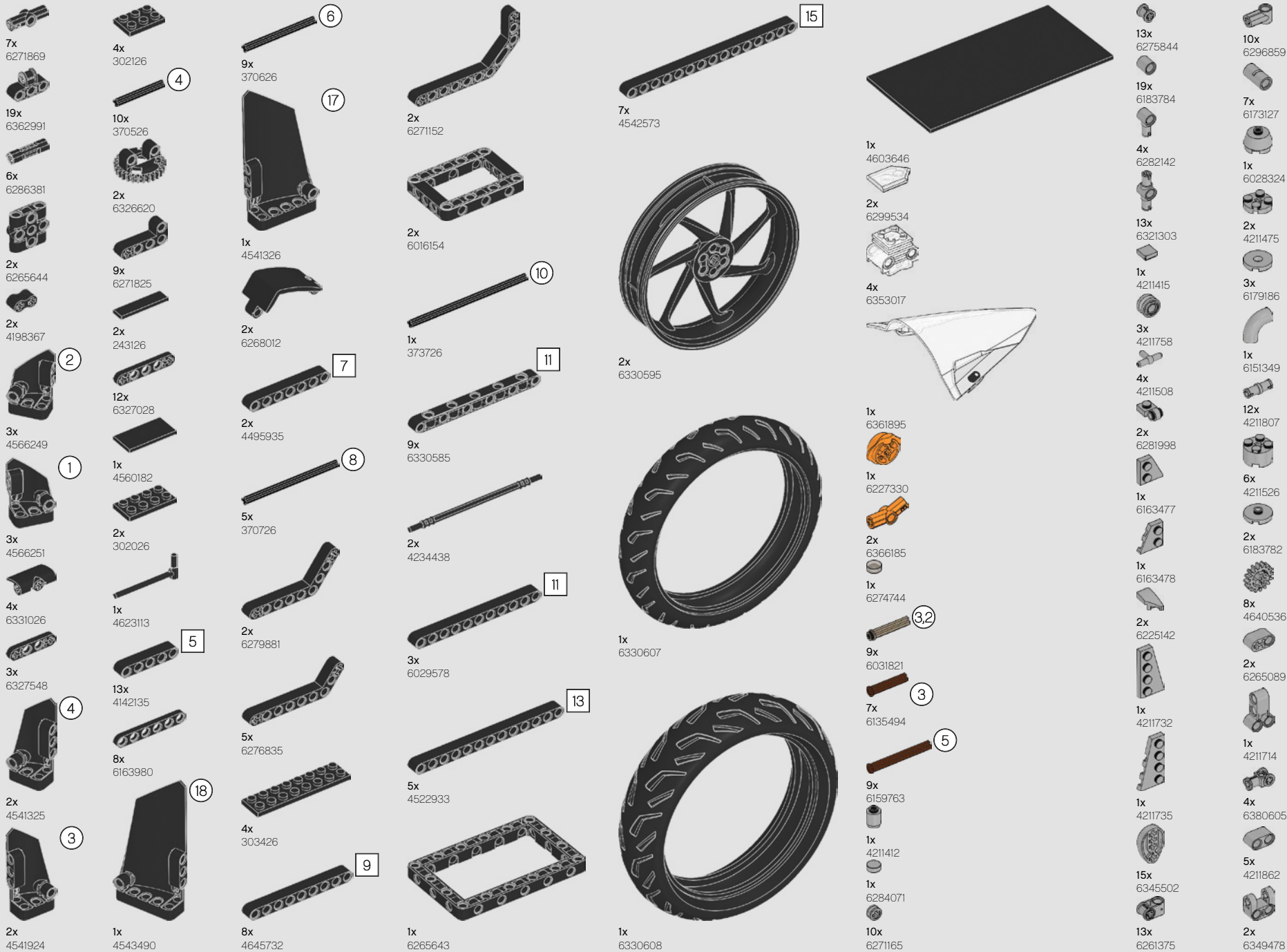

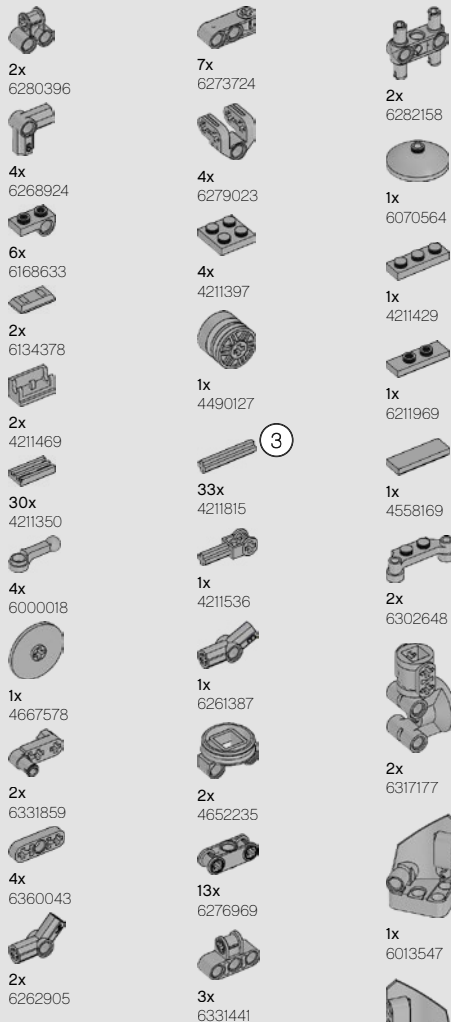

Customer Service
Kundenservice
Service Consommateurs
Servicio Al Consumidor

LEGO.com/service or dial





FEEDBACK AND WIN



FEEDBACK AND WIN

Your feedback will help shape the future development of this product series.

Please visit:

FEEDBACK UND GEWINNEN

Dein Feedback trägt zur Weiterentwicklung dieser Produktreihe bei.

Geh auf:

COMMENTEZ ET GAGNEZ

Vos commentaires nous aideront à concevoir les futurs produits de cette gamme.

Rendez-vous sur :

COMENTA Y GANA

Tu opinión nos ayudará a dar forma al desarrollo de esta serie de productos en el futuro.

Visita:

反馈有奖

您的反馈将有助于我们在今后改进本系列产品。

请访问：

[LEGO.com/productfeedback](https://www.lego.com/productfeedback)

By completing, you will automatically enter a drawing to win a LEGO® set.

Terms & Conditions apply.

Durch Ausfüllen nimmst du automatisch an der Verlosung eines LEGO® Preises teil.

Es gelten die Teilnahmebedingungen.

En envoyant vos commentaires, vous serez automatiquement inscrit(e) à un tirage au sort qui vous permettra de remporter un prix LEGO®.

Offre soumise à conditions.

Al contestar, participarás automáticamente en el sorteo y podrás ganar un set LEGO®.

Sujeto a Términos y Condiciones.

完成我们的反馈调查,即可自动进入抽奖环节,赢取乐高®套装。

适用《条款和条件》。

LEGO and the LEGO logo are trademarks of the/son des marques de commerce du/son marcas registradas de LEGO Group. ©2022 The LEGO Group.

The BMW logo, the BMW Motorrad word mark and the BMW Motorrad model designation are trademarks of BMW AG and are used under license.



M 1000 RR