

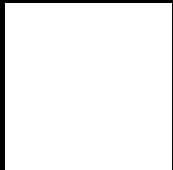

Booklet available in English on
Livret disponible en français sur
Folleto disponible en español en







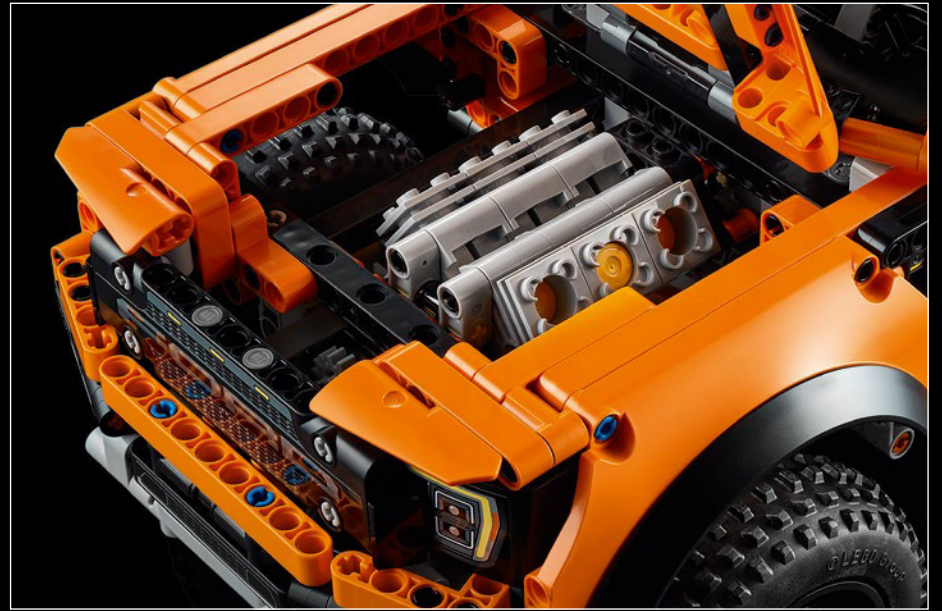

A WORKHORSE ON WHEELS

Un véhicule à toute épreuve

Un caballo de batalla sobre ruedas

It's difficult to imagine any other type of vehicle that symbolizes America more than the pickup truck. Born over a century ago, the original rugged American pickup has been transformed through constant innovation into a state-of-the-art, modern luxury hauler.

Il est difficile d'imaginer un véhicule plus représentatif de l'Amérique que la camionnette. Créée il y a plus d'un siècle, la robuste camionnette américaine est devenue au fil du temps un poids lourd moderne de luxe à la fine pointe de la technologie.

Es difícil imaginar un vehículo que represente el espíritu de Estados Unidos mejor que la camioneta. Nacida hace más de un siglo, la robusta camioneta americana original se ha transformado, gracias a un constante esfuerzo innovador, en un moderno y lujoso vehículo de transporte.



MODEL TT / MODÈLE TT / MODELO TT

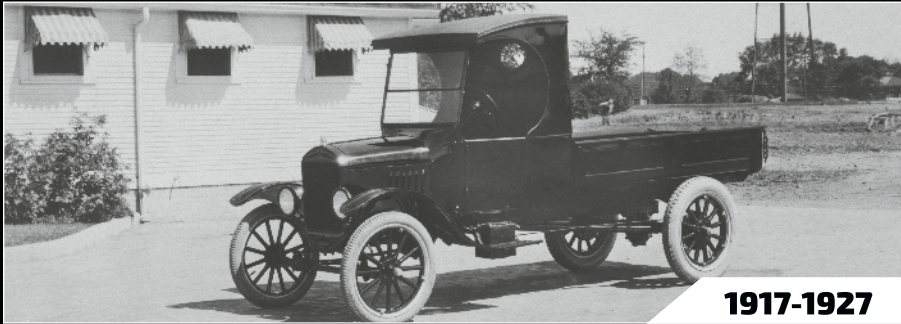

1917-1927

If the Model T put America on wheels, the Model TT put it to work. With its one-ton (0.9 metric ton) payload and plentiful third-party pickup-bed configurations, this versatile workhorse became a regular sight on US roads.

Si le modèle T a mis l'Amérique sur des roues, le modèle TT l'a mise en route. Avec sa charge utile d'environ une tonne et ses nombreuses configurations de plateau de tiers fournisseurs, ce véhicule polyvalent devient monnaie courante sur les routes américaines.

Si el Modelo T les dio ruedas a los estadounidenses, el Modelo TT los puso a trabajar. Con una carga útil de 0,9 t y un amplio número de configuraciones para la caja de transporte disponibles a través de otros fabricantes, la versátil bestia motorizada llegó a convertirse en un elemento habitual en las carreteras de Estados Unidos.

1917

1935

1948

1961

F-SERIES / SÉRIE F / SERIE F



1948-1952

The first-generation F-series marked Ford's new expanded truck strategy that offered a range of pickups in different sizes and with various hauling capabilities.

La Série F de première génération marque un tournant important pour Ford, alors que l'entreprise diversifie sa gamme en proposant des camionnettes de différentes tailles et avec des capacités de transport variées.

La primera generación de la Serie F definió la nueva estrategia de Ford para sus camiones, que ampliaba su oferta con una gama de camionetas de diferentes tamaños y con diversas capacidades de carga.

FORD MODEL 50 PICKUP / CAMIONNETTE FORD MODÈLE 50 / FORD MODELO 50 PICKUP



1935-1941

Powered by the legendary Ford flathead V-8 engine, more than four million of these sturdy pickups were produced between 1935 and 1941.

Propulsée par le légendaire moteur V8 à tête plate de Ford, la robuste camionnette est produite à plus de quatre millions d'exemplaires entre 1935 et 1941.

Equipadas con el legendario motor Ford V8 de cabeza plana, se fabricaron más de cuatro millones de estas robustas camionetas entre 1935 y 1941.

FOURTH GENERATION / QUATRIÈME GÉNÉRATION / CUARTA GENERACIÓN



1961-1966

With the slogan "Drives like a car, works like a truck," this was the first pickup to also be targeted at non-commercial truck users.

Avec le slogan « Elle se conduit comme une voiture et est robuste comme un camion », c'est la première camionnette à être destinée aux utilisateurs de camions non commerciaux.

Publicitada con el eslogan "Se conduce como un auto, funciona como un camión", fue la primera camioneta dirigida también a los usuarios de camiones no comerciales.

SIXTH GENERATION / SIXIÈME GÉNÉRATION / SEXTA GENERACIÓN



1973-1979

Continuing to make comfort a priority, this latest F-150 introduced a much-improved heating and air-conditioning system. To increase safety, the fuel tank was also moved out of the cab.

Le confort étant toujours une priorité, ce nouveau modèle F-150 présente un système de chauffage et de climatisation des plus sophistiqués. Dans un souci d'accroître la sécurité, le réservoir de carburant est également déplacé hors de la cabine.

Todavía con el confort como máxima prioridad, este último modelo F-150 se equipó con un sistema de calefacción y aire acondicionado muy mejorado. Para aumentar la seguridad, el tanque de combustible se trasladó fuera de la cabina.

1973

1987

TENTH GENERATION / DIXIÈME GÉNÉRATION / DÉCIMA GENERACIÓN



1997-2003

Focusing on personal use, the F-150 was given a dramatic re-design, including a new V6 engine and four full-size doors. Modern lines and new technology earned the F-150 an increase in sales and a Truck of the Year award.

Dans l'optique de mettre l'accent sur l'usage personnel, la F-150 fait l'objet d'une transformation radicale qui propose entre autres un nouveau moteur V6 et quatre portes pleine grandeur. Les lignes modernes et les nouvelles technologies valent à la F-150 des ventes accrues et le prix de Camionnette de l'année.

Prestando más atención al uso personal, el modelo F-150 pasó por una espectacular reconcepción que dio lugar a la adopción de un nuevo motor V6 y cuatro puertas de tamaño completo. Las modernas líneas y mejoras tecnológicas provocaron un aumento de las ventas y le valieron el premio Truck of the Year a la camioneta.

1997

2009

EIGHTH GENERATION / HUITIÈME GÉNÉRATION / OCTAVA GENERACIÓN



1987-1991

This generation went through many revised body panels and redesigns interior. Most importantly, this generation saw the introduction of electronic fuel injection engines making the F-150 more powerful and efficient.

Cette génération subit de nombreux changements au niveau des panneaux de carrosserie et de la conception de l'intérieur. Mais surtout, cette génération voit l'arrivée des moteurs à injection électronique de carburant, qui rehaussent la puissance et l'efficacité de la F-150.

Para esta generación se revisaron muchos de los paneles de la carrocería y se rediseñó gran parte del interior. Sin embargo, la mayor novedad que trajo consigo fue la introducción de motores de inyección electrónica de combustible que incrementaron la potencia y eficiencia del modelo F-150.

TWELFTH GENERATION / DOUZIÈME GÉNÉRATION / DUODÉCIMA GENERACIÓN



2009-2014

With 20 in. (50.8 cm) chrome wheels, leather upholstery and heated and ventilated seats, this generation of the F-150 offered a new level of luxury for customers.

Avec ses roues chromées de 50,8 cm (20 po) et ses sièges chauffants et ventilés en cuir, cette génération de F-150 offre un nouveau niveau de luxe aux consommateurs.

Con rines cromados de 50,8 cm, tapicería de piel y asientos con calefacción y ventilación incorporadas, esta generación del modelo F-150 ofrecía un nuevo nivel de lujo a los clientes.



THE 3RD GENERATION FORD F-150 RAPTOR
LA FORD F-150 RAPTOR 3^e GÉNÉRATION
TERCERA GENERACIÓN DE LA FORD F-150 RAPTOR

It's been a long journey from the first Model TT to the latest 2021 incarnation of the F-150 Raptor, but the spirit remains very much the same. Created by Ford Performance, the Raptor is a high-performance, street-legal truck and one of the most capable factory off-road vehicles. It combines the most powerful engine in the F-150 range with rugged off-road-ready suspension.

La camionnette a fait beaucoup de chemin depuis le premier modèle TT jusqu'à la version 2021 de la F-150 Raptor, mais son esprit reste le même. Créée par Ford Performance, la Raptor est une camionnette haute performance conforme à la conduite sur route et l'un des véhicules construits en usine le plus parfaitement conçu pour le hors route. Elle allie le moteur le plus puissant de la gamme F-150 à une suspension robuste à capacité tout-terrain.

Ha pasado mucho tiempo entre el Modelo TT y su más reciente reencarnación en la F-150 Raptor de 2021, pero el espíritu de esta eyenda apenas ha cambiado. Creada por Ford Performance, la Raptor es un vehículo de alto rendimiento homologado para la conducción en carretera y uno de los autos todoterreno fabricados en serie más versátiles. Combina el motor más potente de la gama F-150 con una robusta suspensión apta para circular fuera de la carretera.

“

QUALITY MEANS DOING IT RIGHT WHEN NO ONE IS LOOKING”

« La qualité, c'est de bien faire les choses quand personne ne regarde. »

“Calidad es hacerlo bien cuando nadie está mirando”.

Henry Ford





FROM THE DESIGN TEAM

*Un mot de l'équipe de conception
Impresiones del equipo de diseño*

The LEGO® Technic™ design team worked closely with the designers and engineers at Ford to ensure the Technic version of the F-150 Raptor would be as close to the real thing as possible. The biggest challenge for the team was to create a rear-axle configuration and suspension structure that would allow the rear wheels and wheel arches to perfectly align.

L'équipe de conception de LEGO® Technic™ a travaillé en étroite collaboration avec les concepteurs et les ingénieurs de Ford pour assurer que la version Technic de la F-150 Raptor imite le plus fidèlement possible la vraie camionnette. Le plus grand défi a été de créer une configuration de l'essieu arrière et une structure de suspension qui permettraient aux roues arrière et aux passages de roues de s'aligner parfaitement.

El equipo de diseño de LEGO® Technic™ trabajó estrechamente con los diseñadores e ingenieros de Ford para garantizar que la versión Technic de la F-150 Raptor se pareciera tanto como fuera posible al vehículo real. El mayor desafío que tuvieron que superar fue configurar el eje trasero y la estructura de suspensión de tal modo que las ruedas y las salpicaderas traseras quedaran perfectamente alineadas.

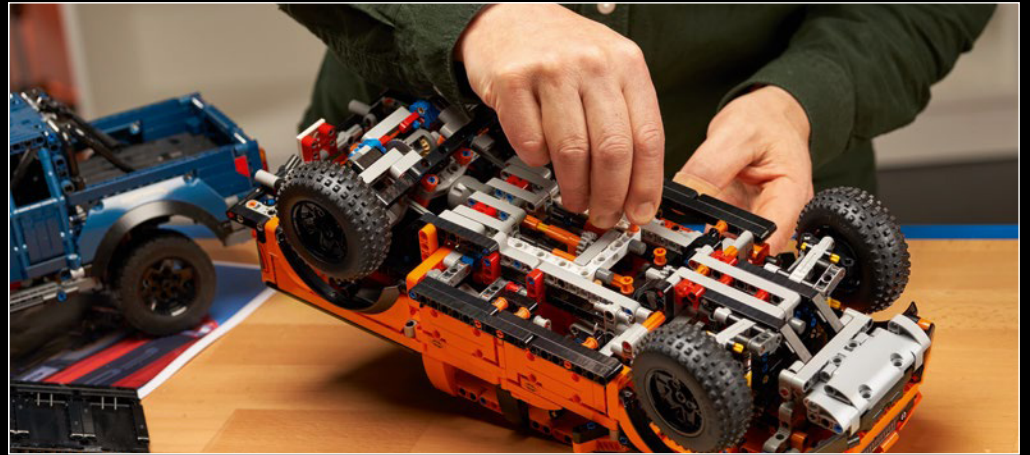

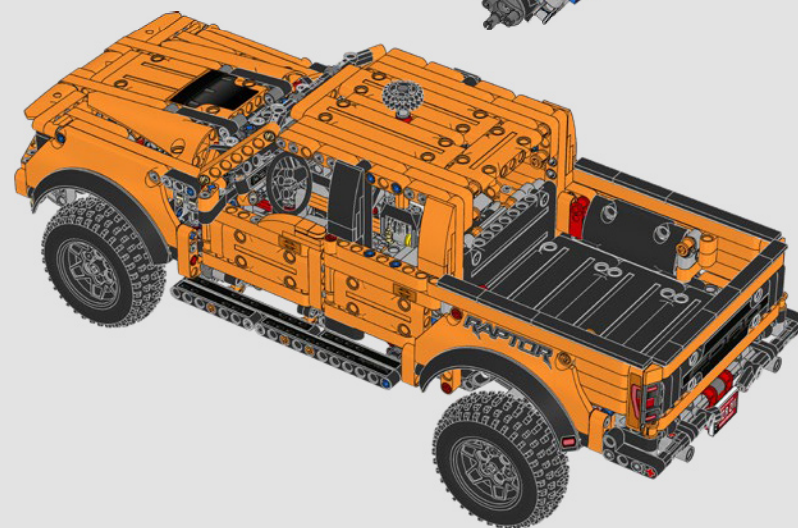
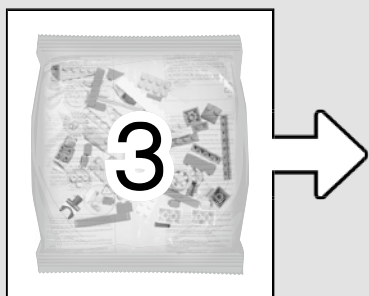
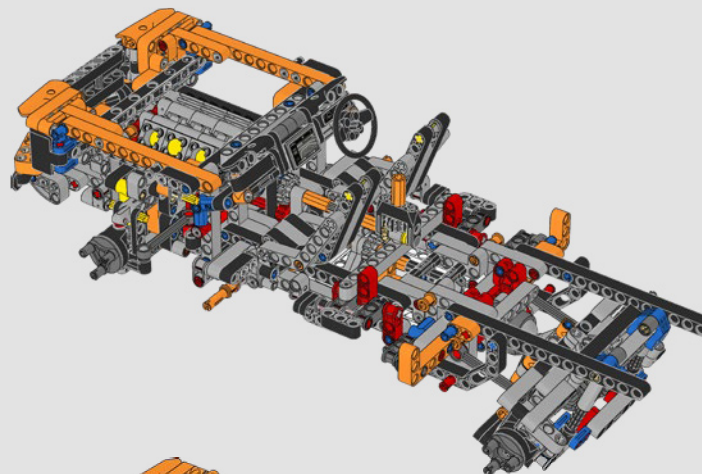
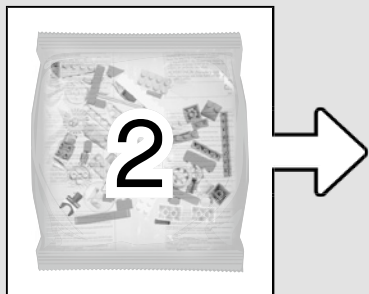
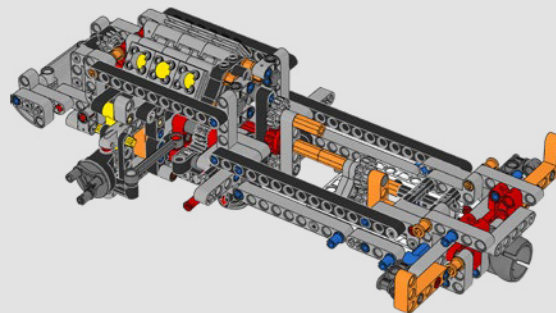

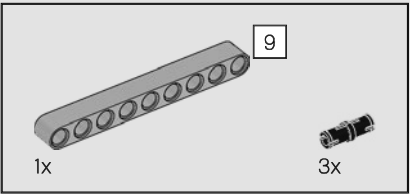
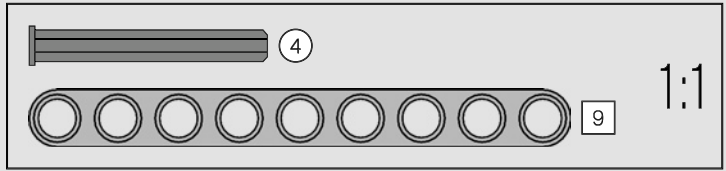
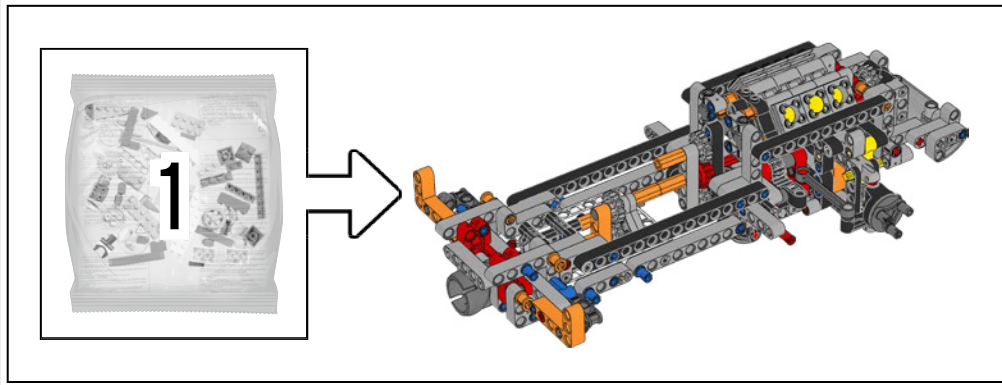

1

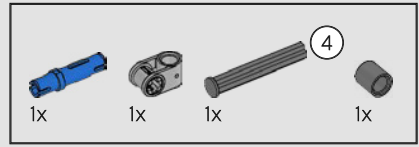
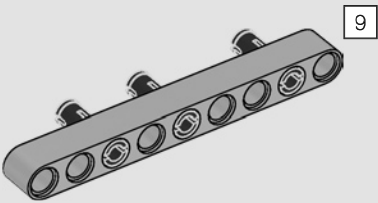

2

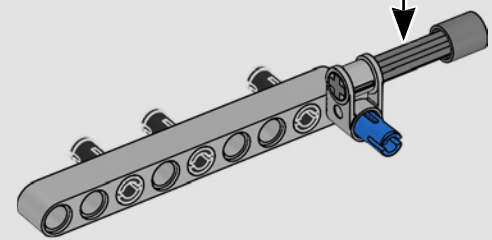
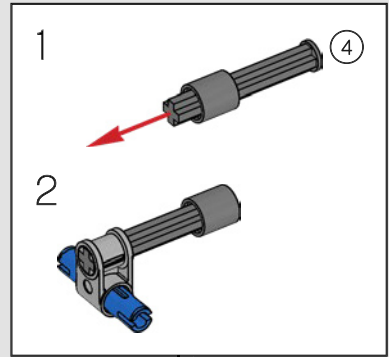

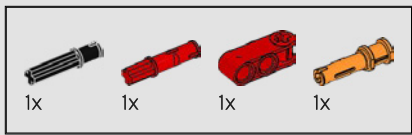

3

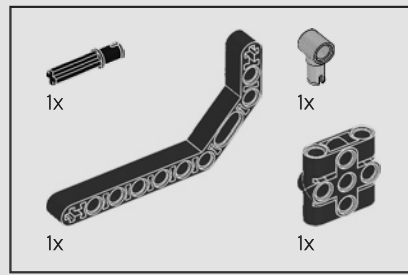
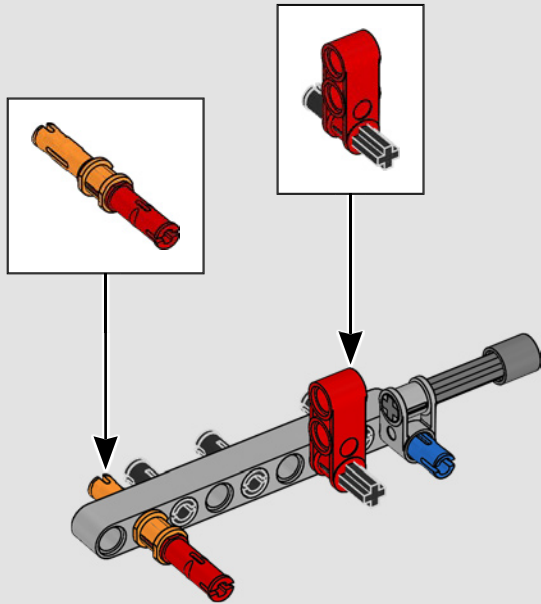

4

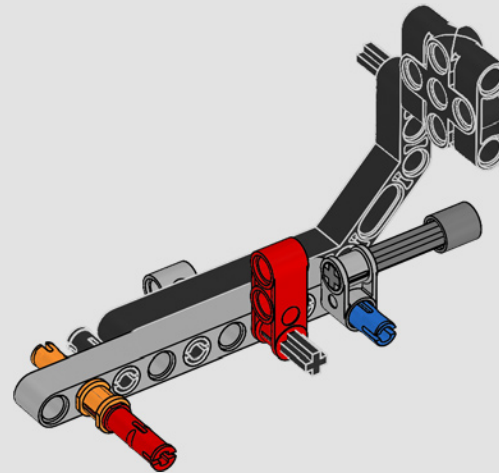
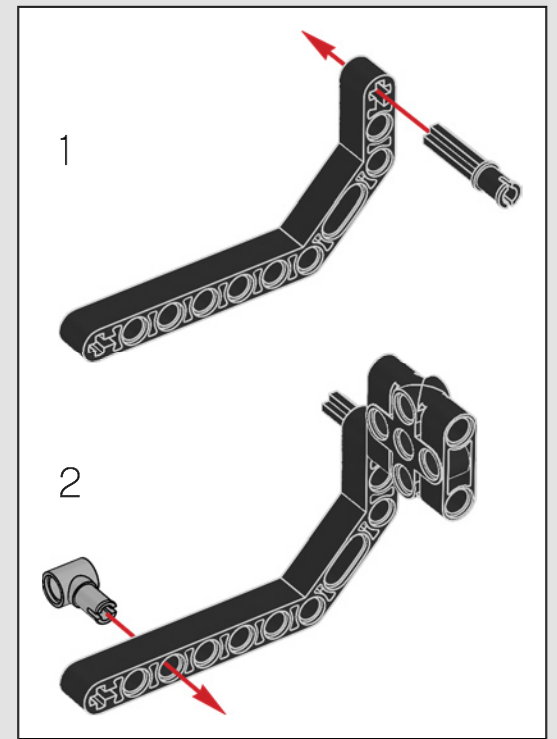

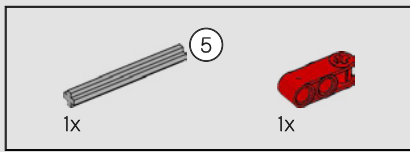

5

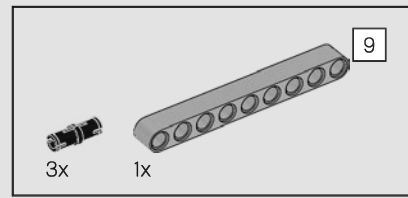
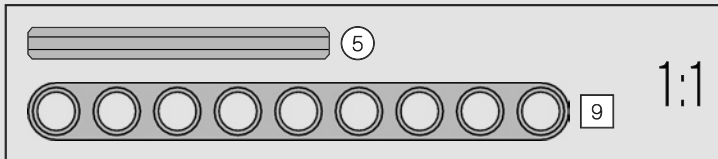
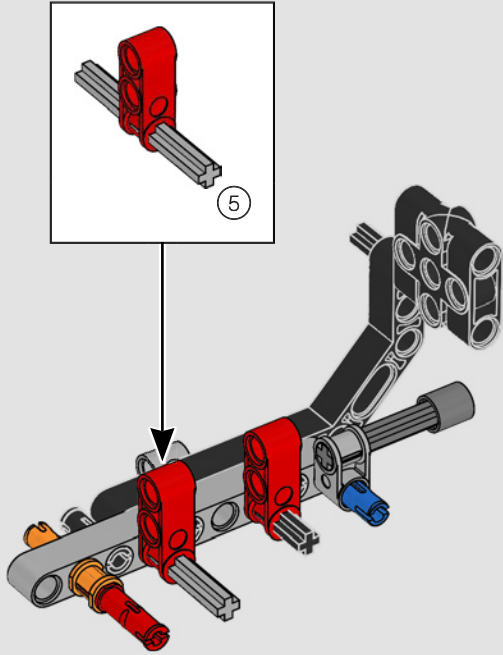

6

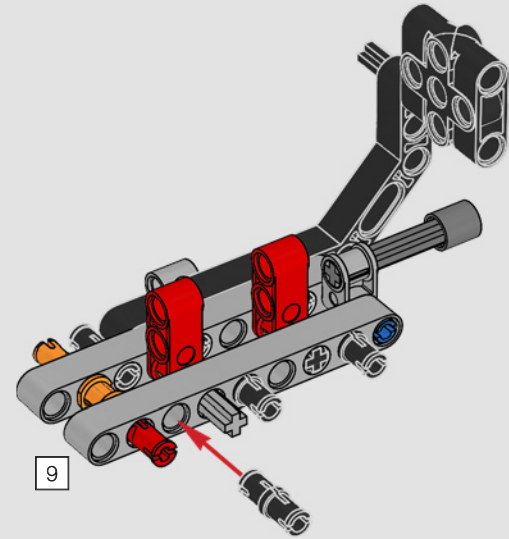

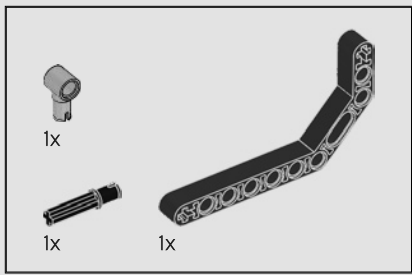

7

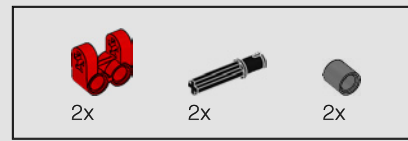
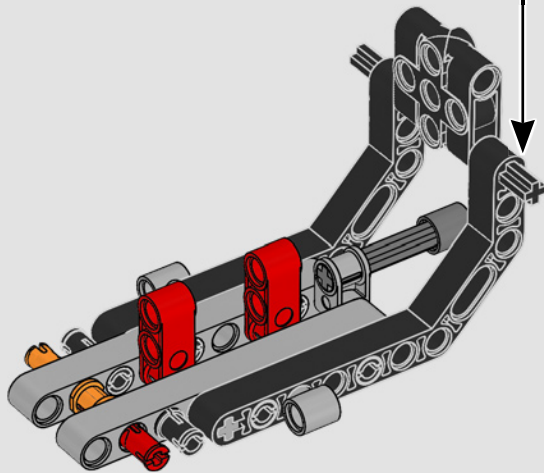
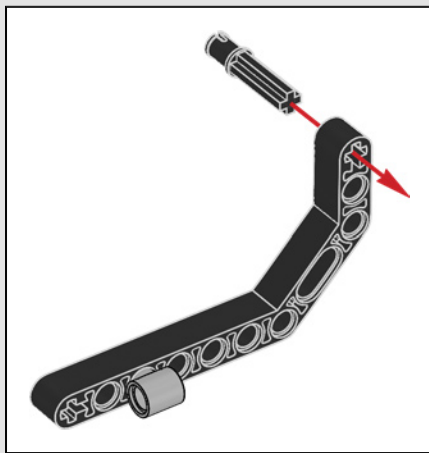

8

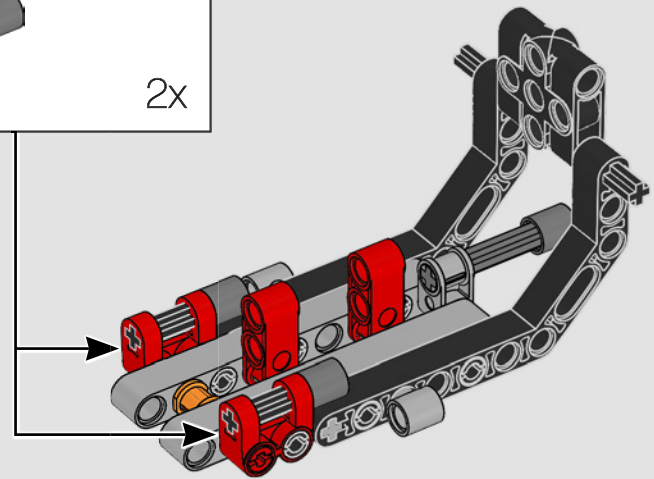
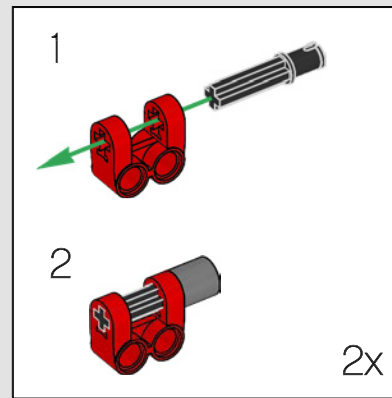

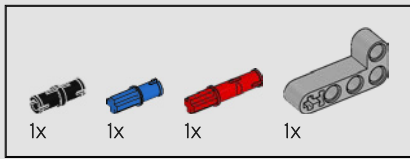

9

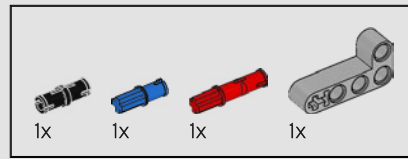
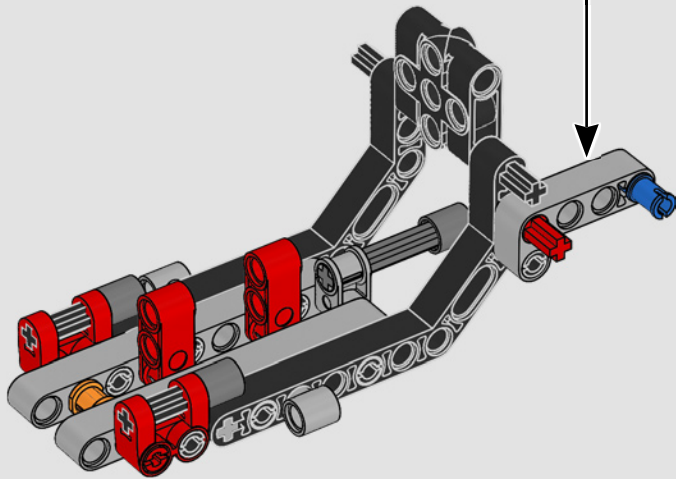
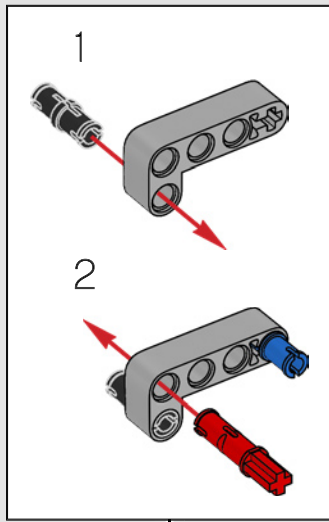

10

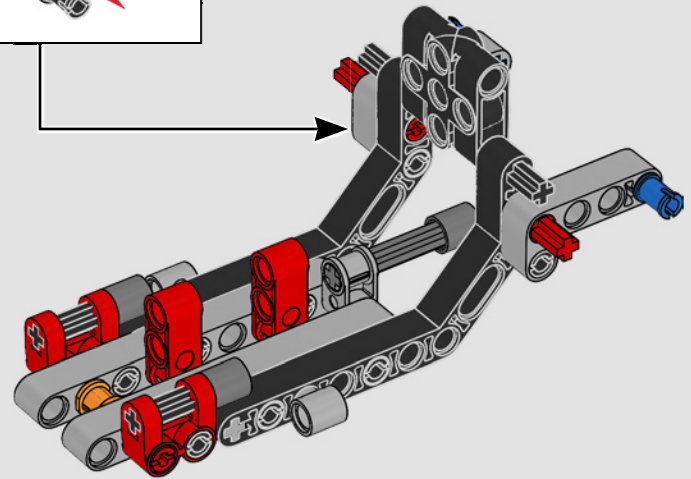
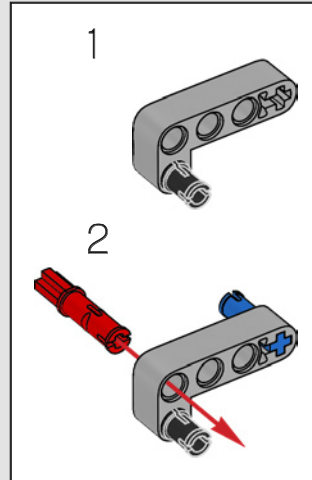



11

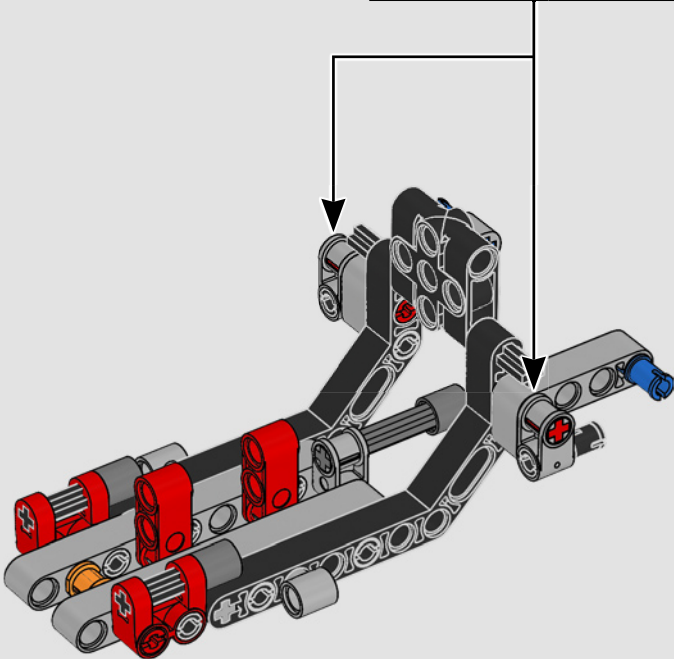
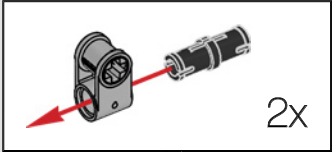

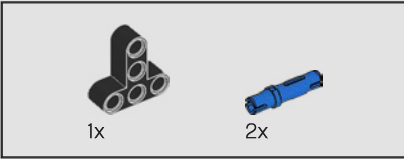
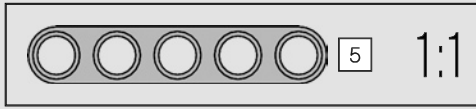
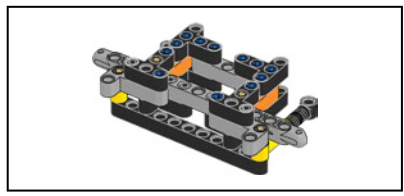

12

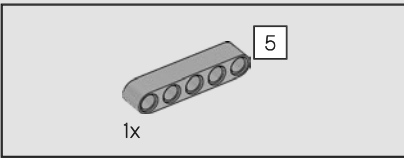
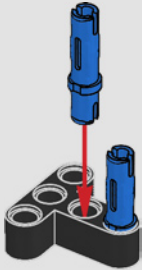

13

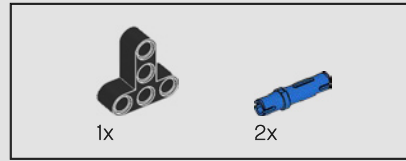
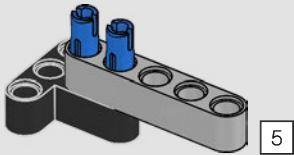

14

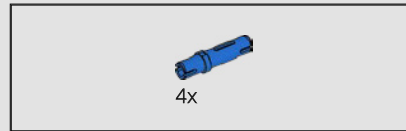
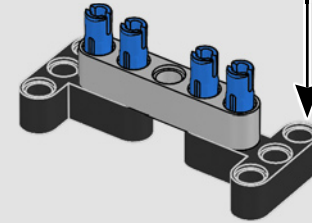
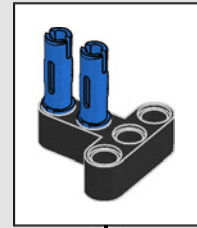

15

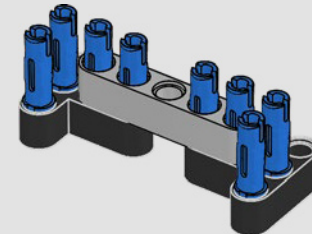

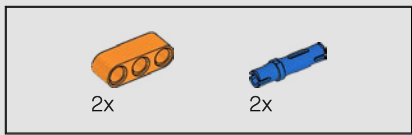

16

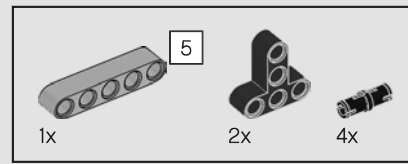
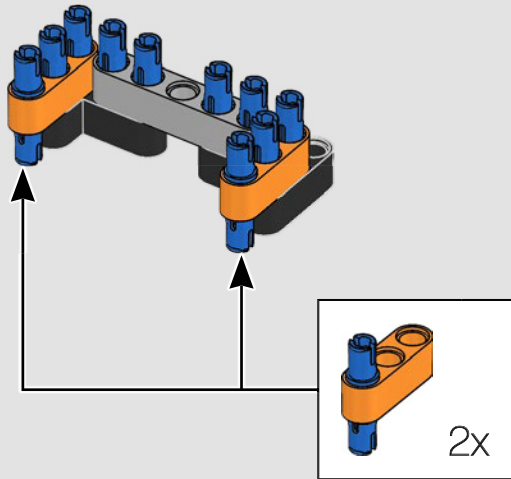

17

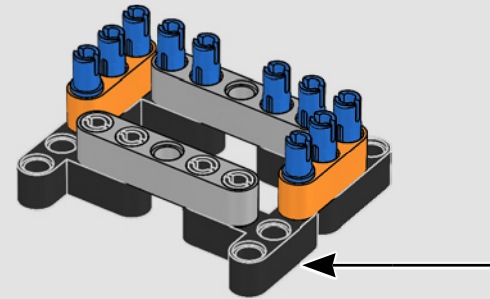
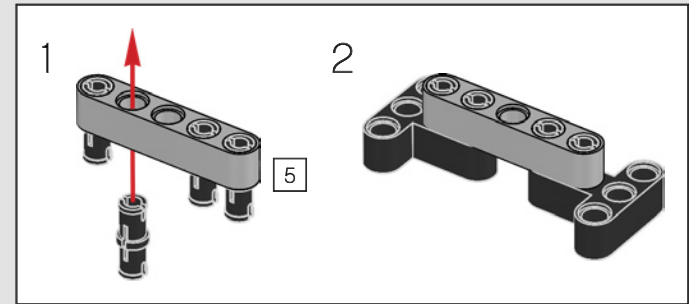

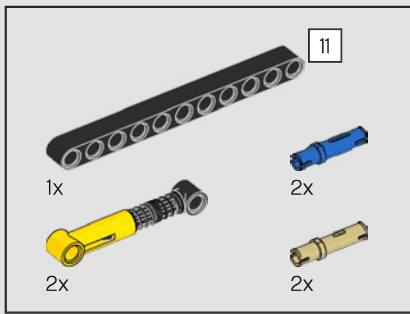

18

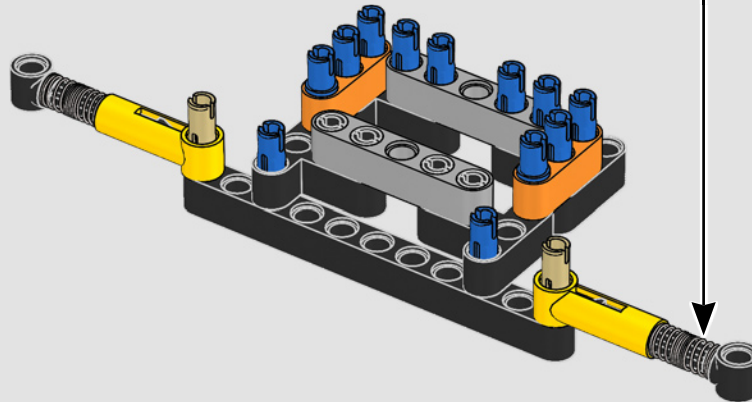
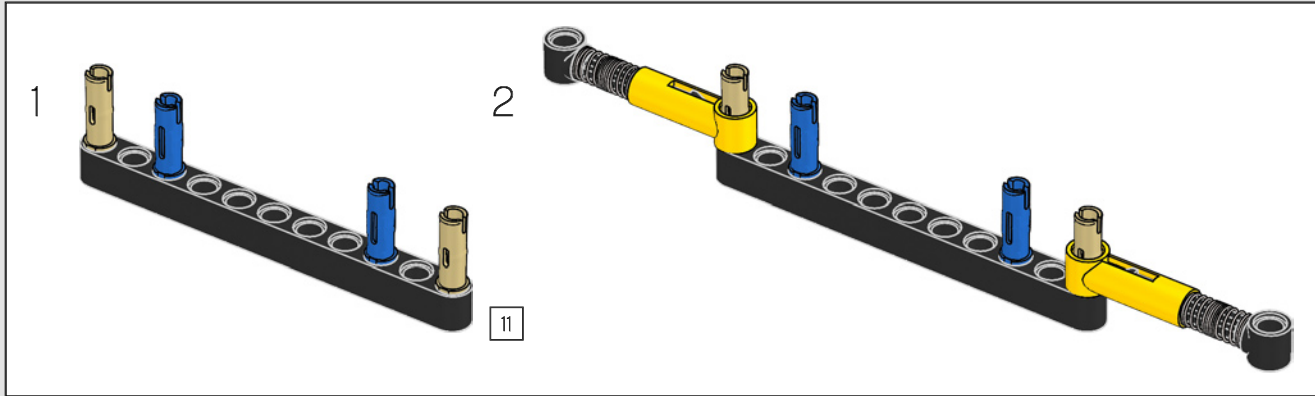

The F-150 Raptor is outfitted with FOX™ Live Valve monotube shocks that automatically adjust to the driving terrain.

La F-150 Raptor est équipée d'amortisseurs monotubes Live Valve de FOX™ qui s'adaptent automatiquement au terrain.

La F-150 Raptor está equipada con amortiguadores monotubo FOX™ Live Valve que se ajustan automáticamente al terreno durante la conducción.



19

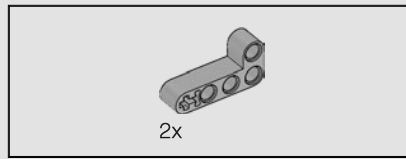
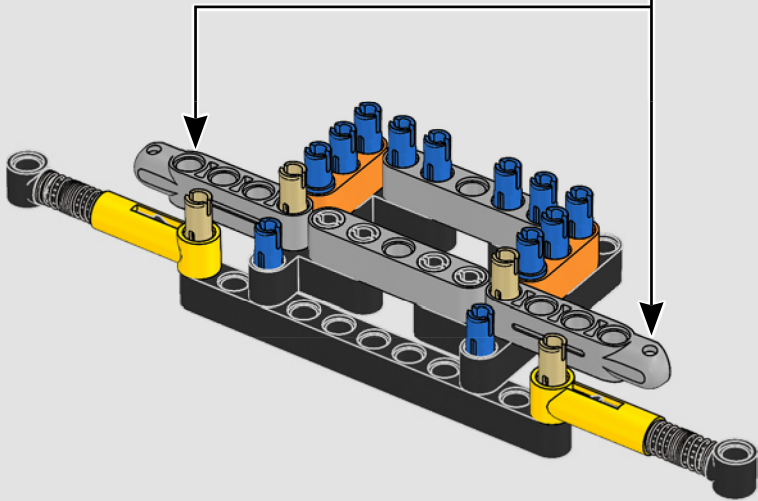
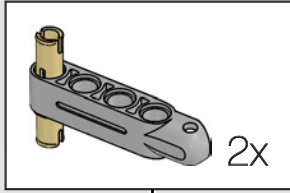
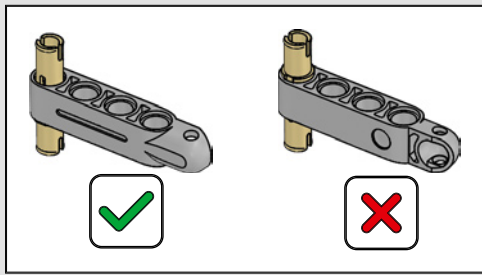

20

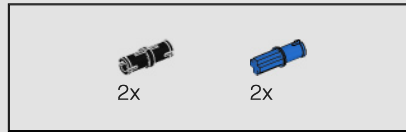
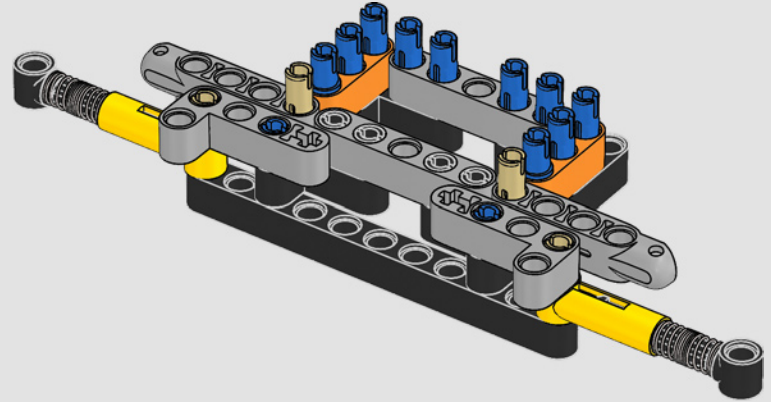

21

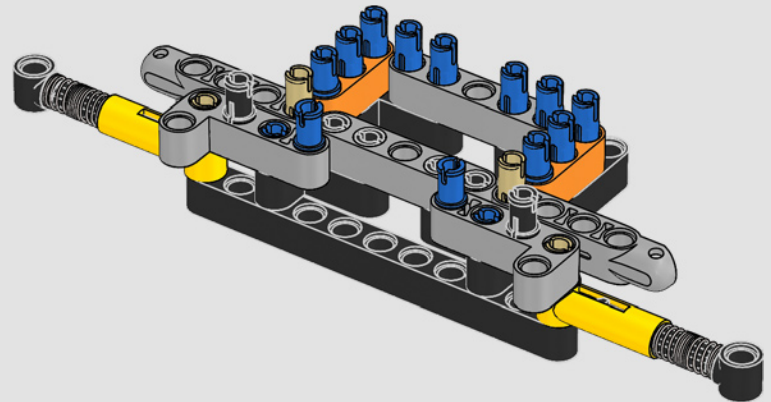

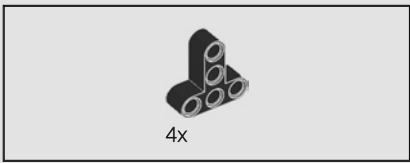

22

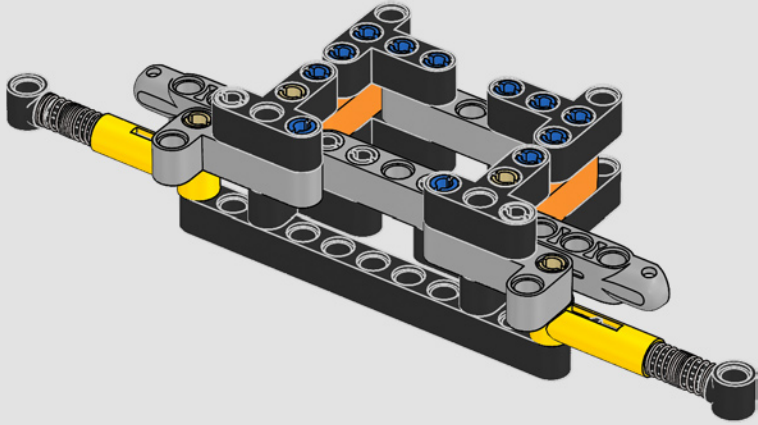

23

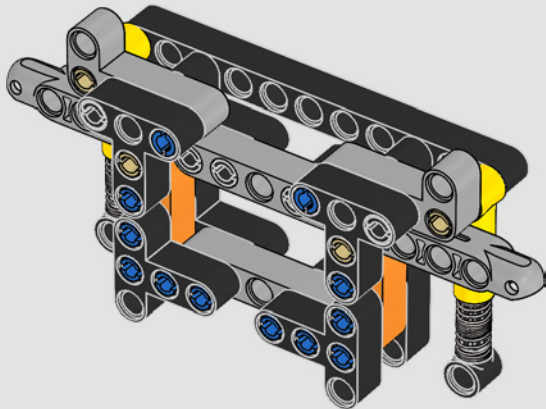

24

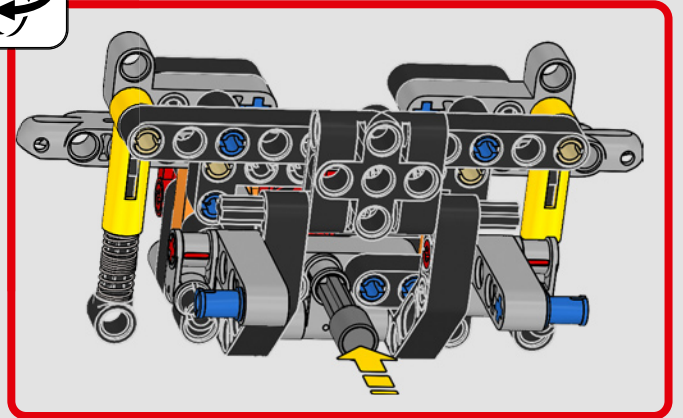
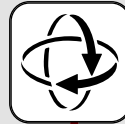
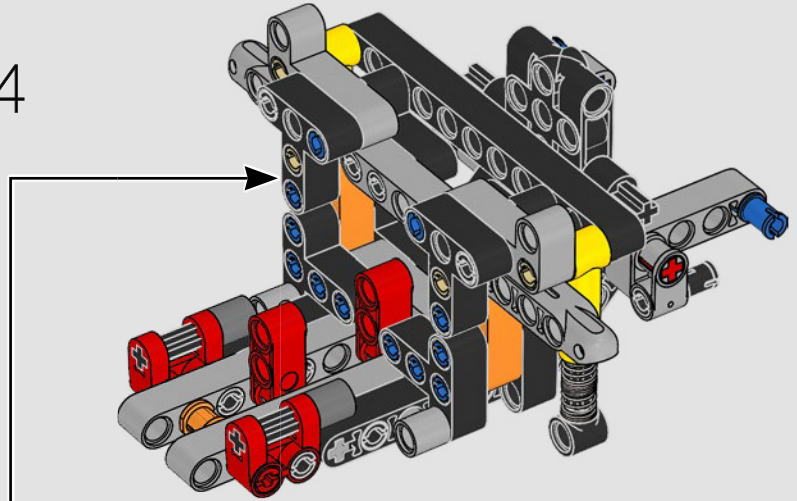

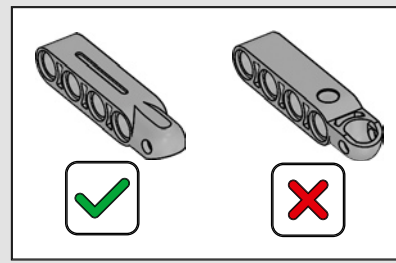
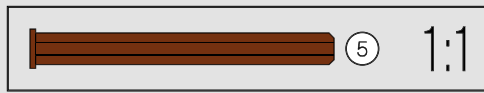
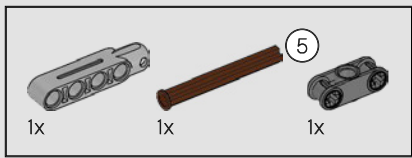

25

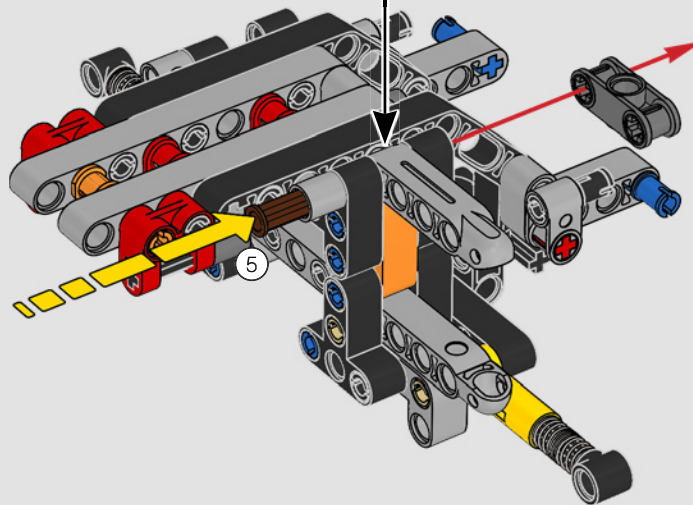
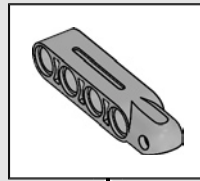

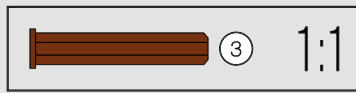
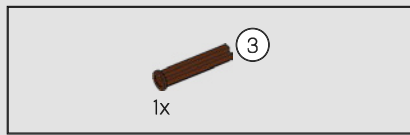

26

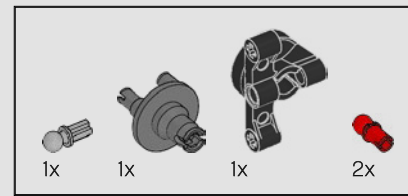
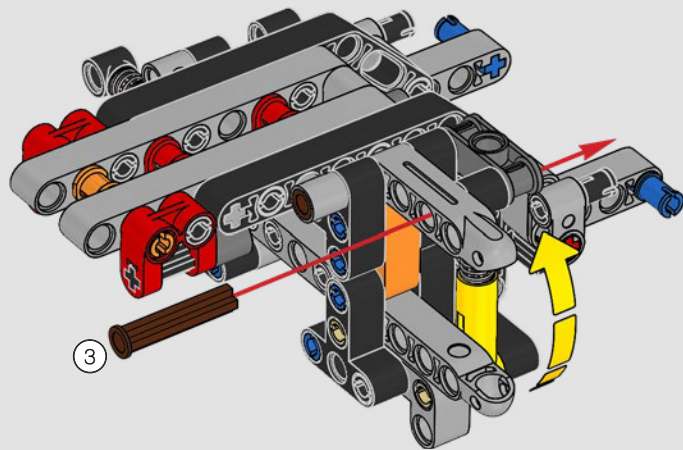

27

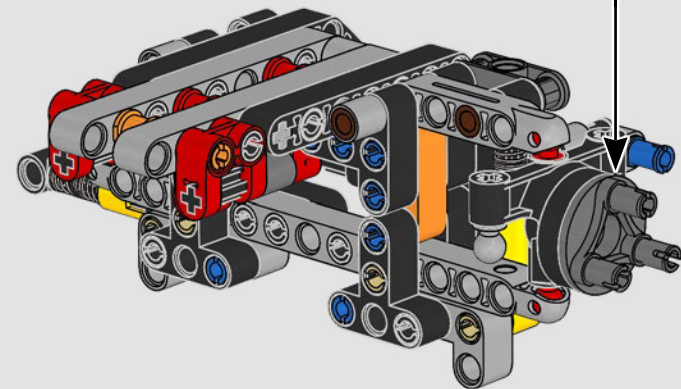
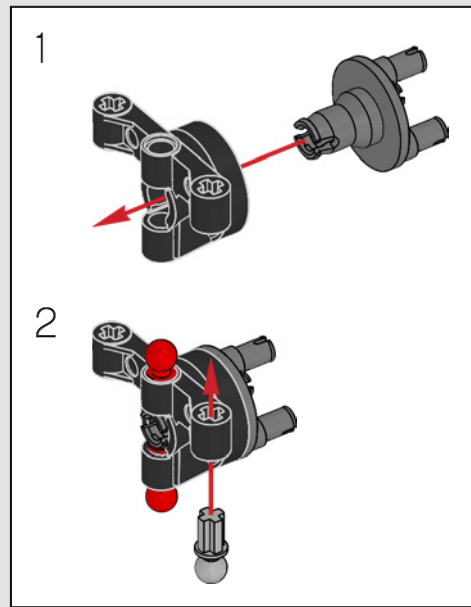

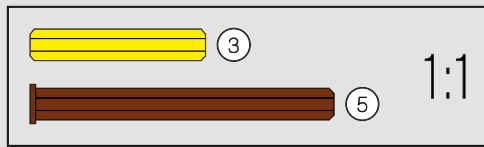
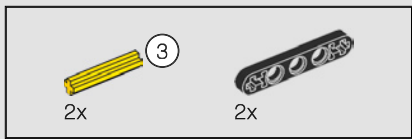

28

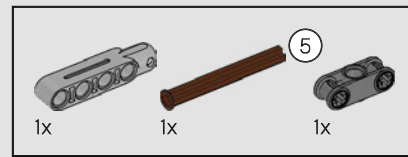
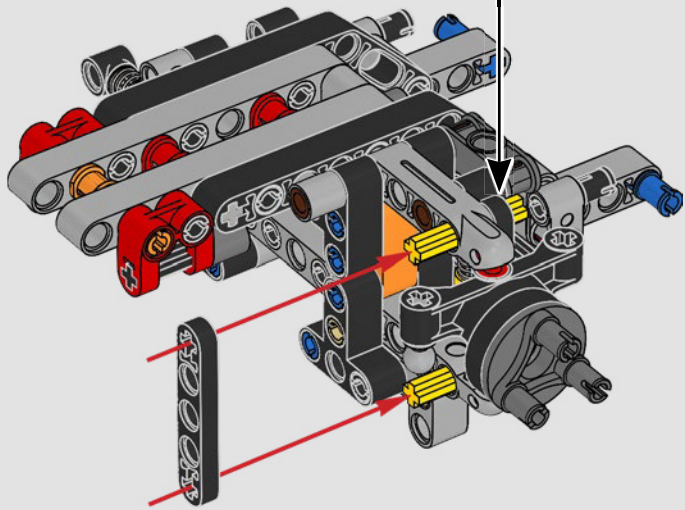
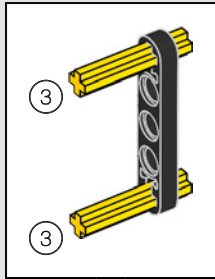

29

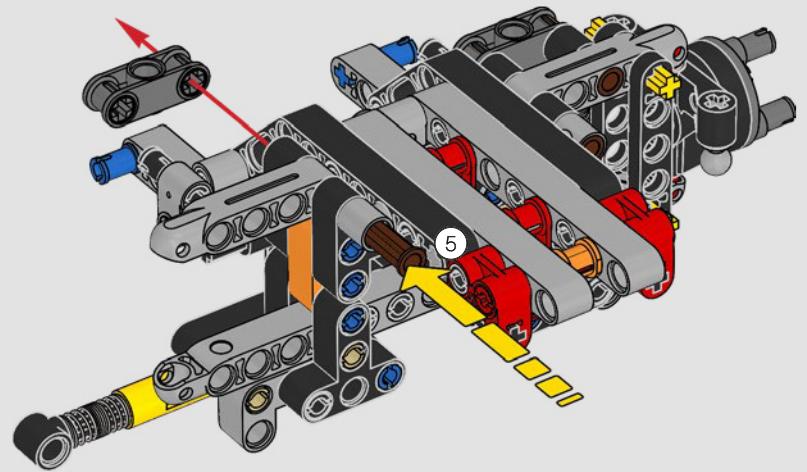
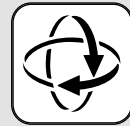

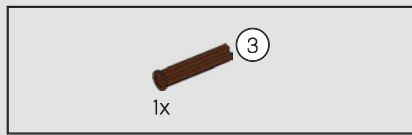

30

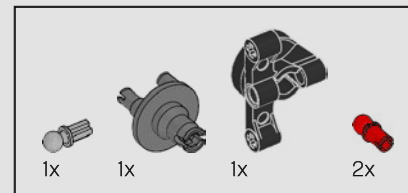
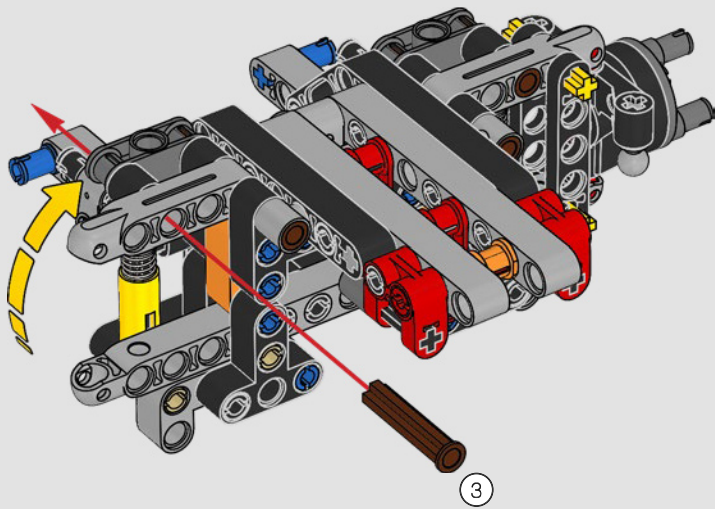

31

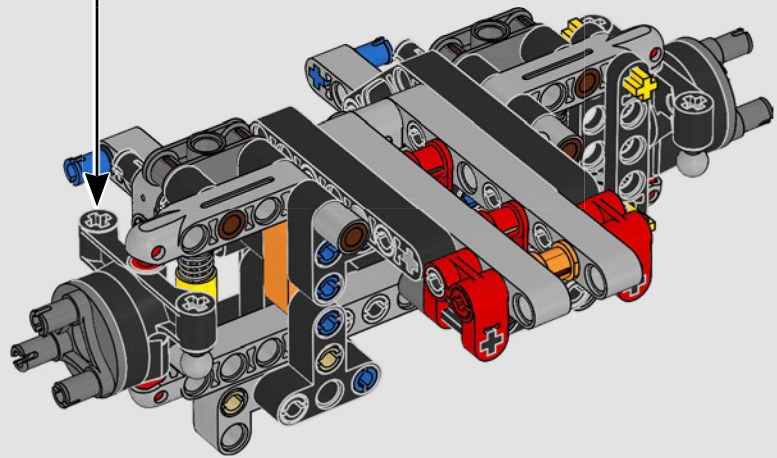
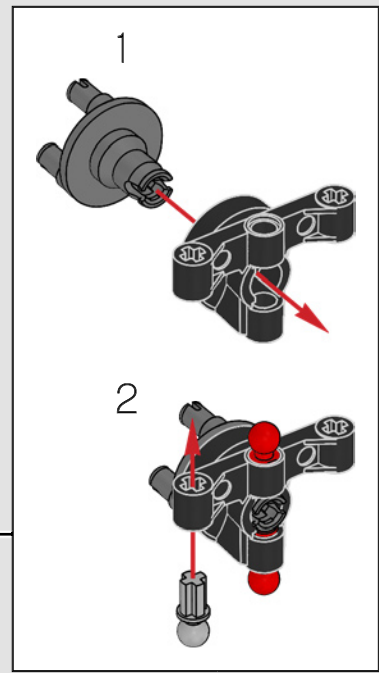

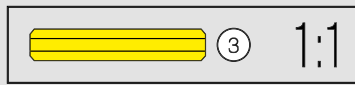
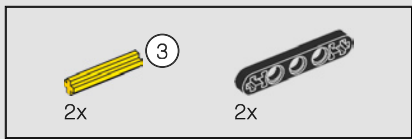

32

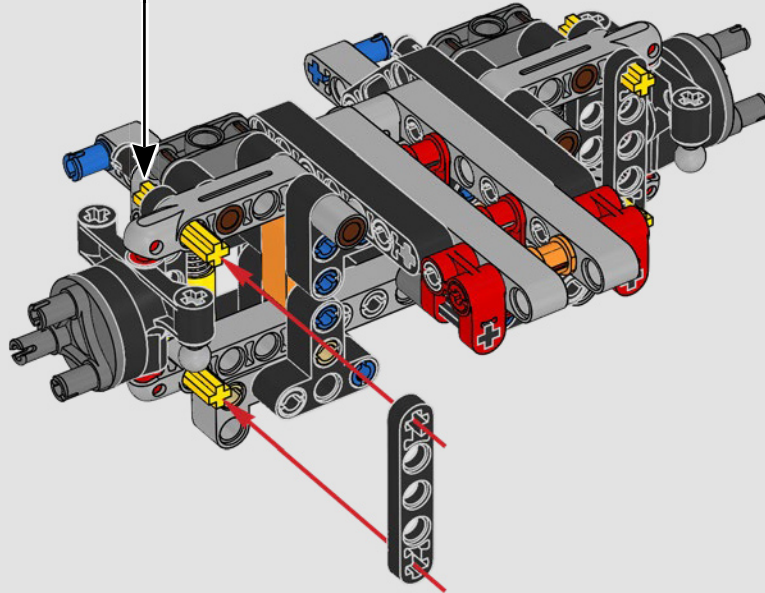
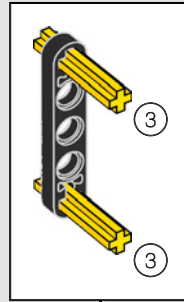

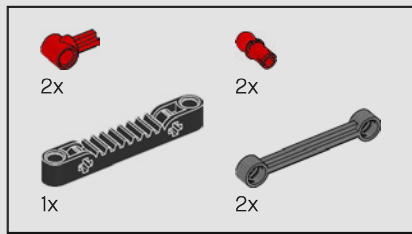

33

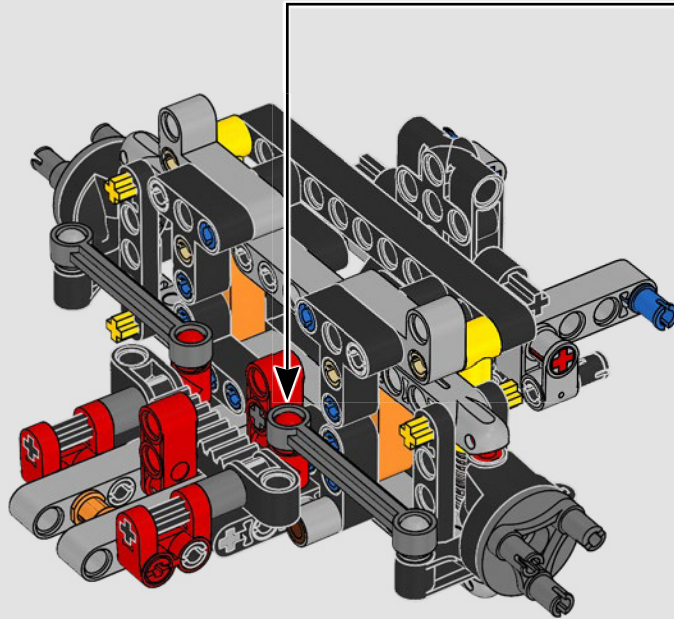
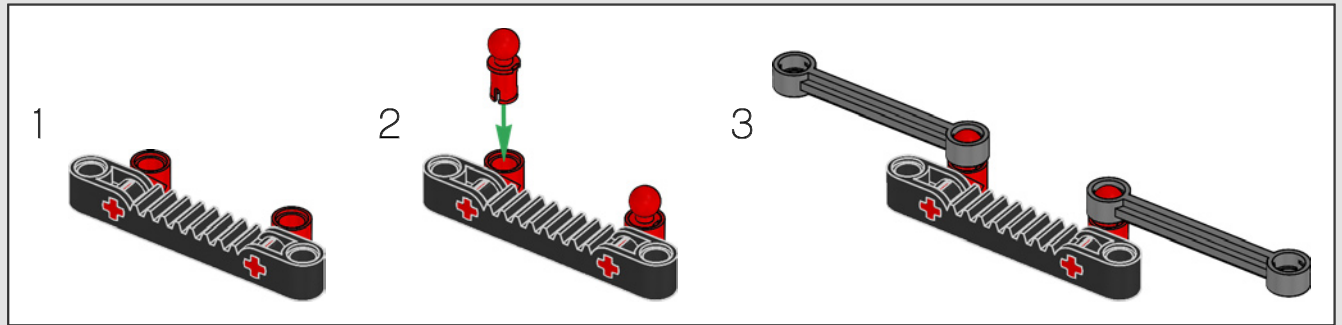

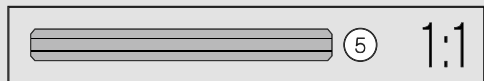
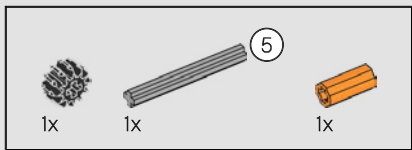

34

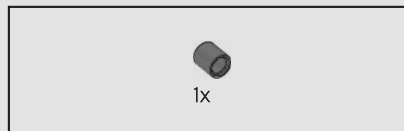
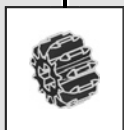
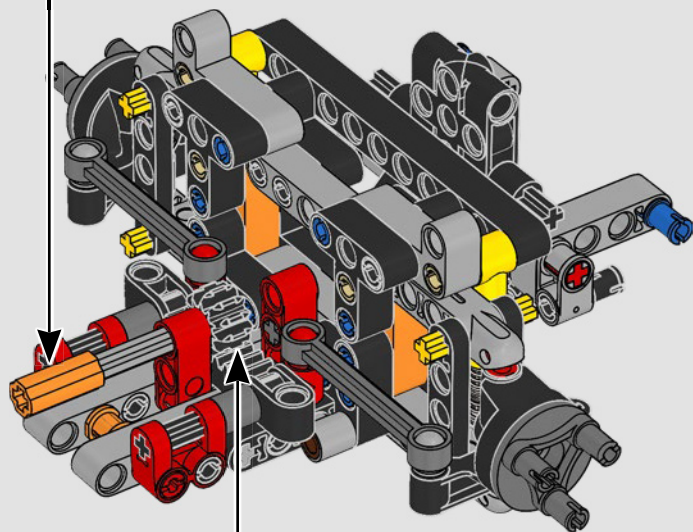
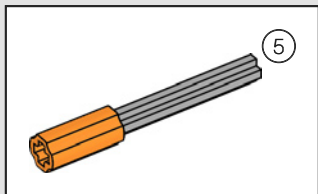

35

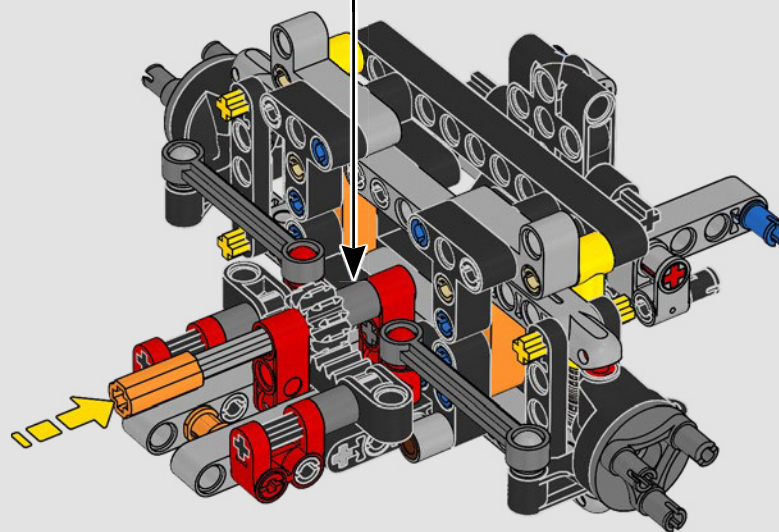

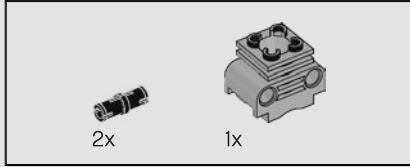
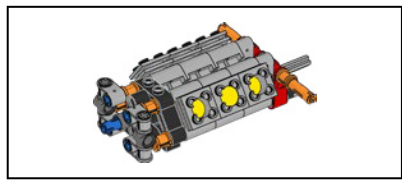

36

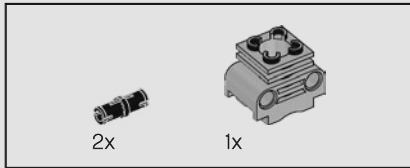
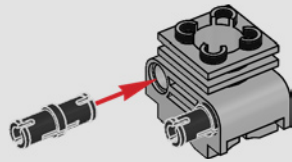

37

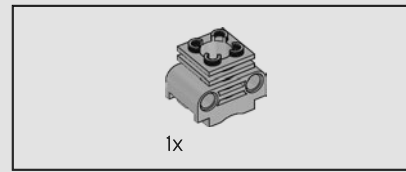
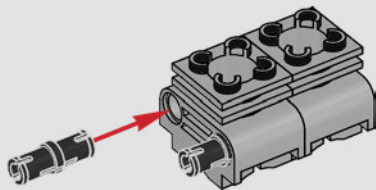

38

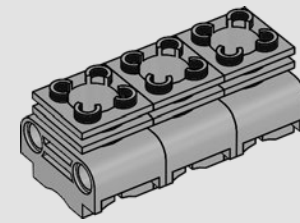

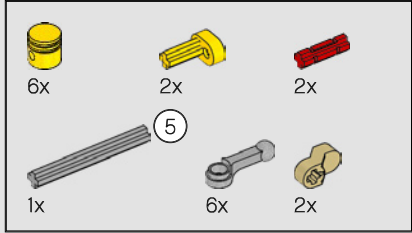
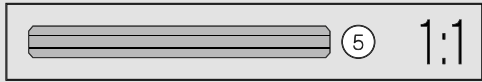
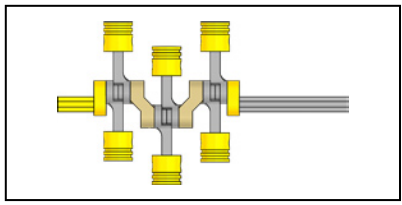

39

1

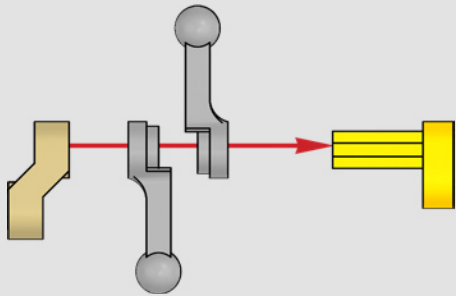

2

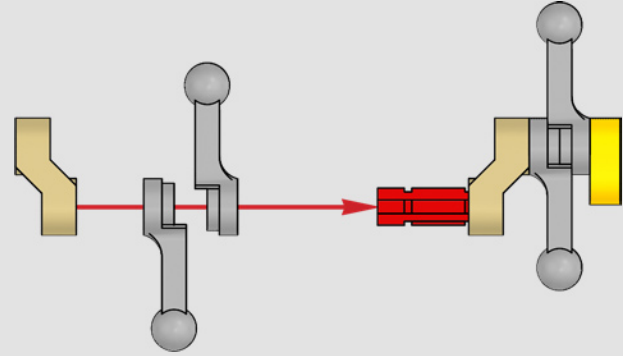

3

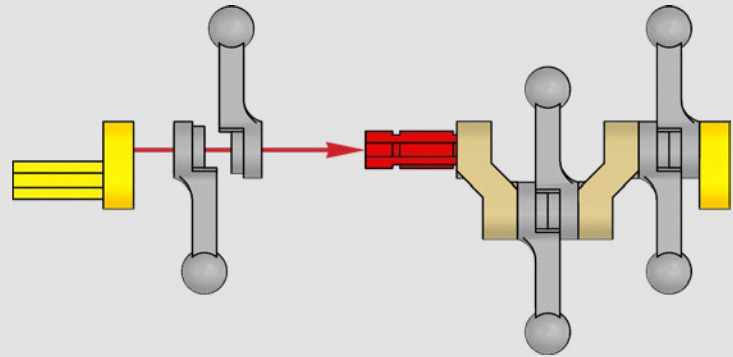

4

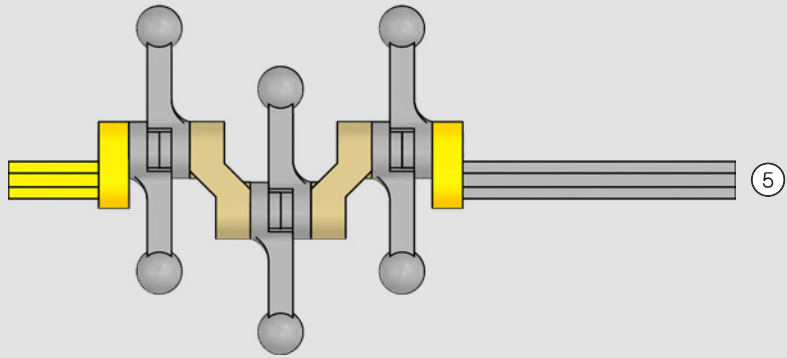

5

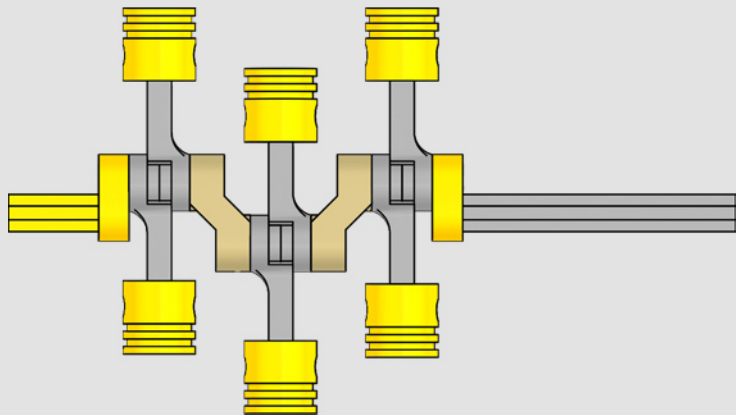

1:1

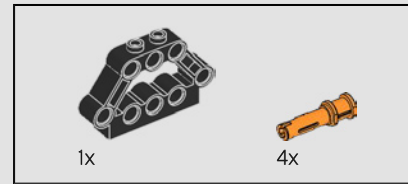
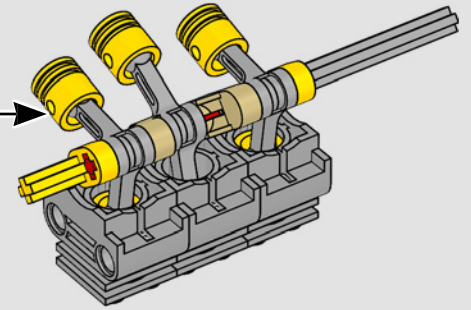
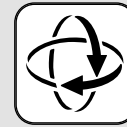

40

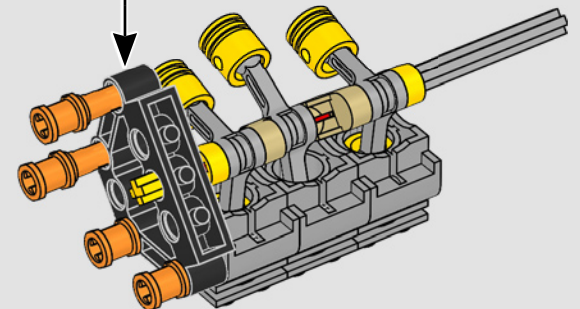
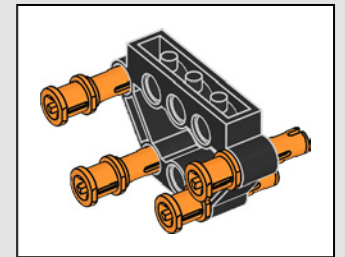

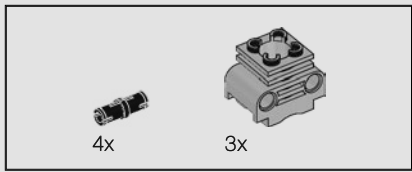

41

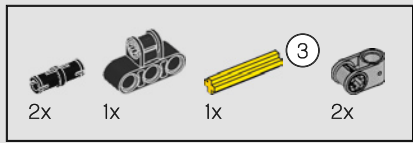
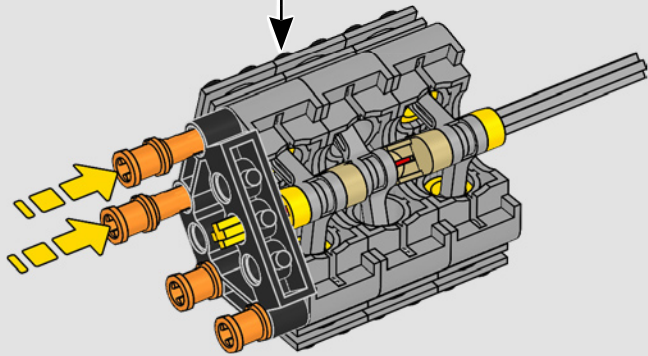
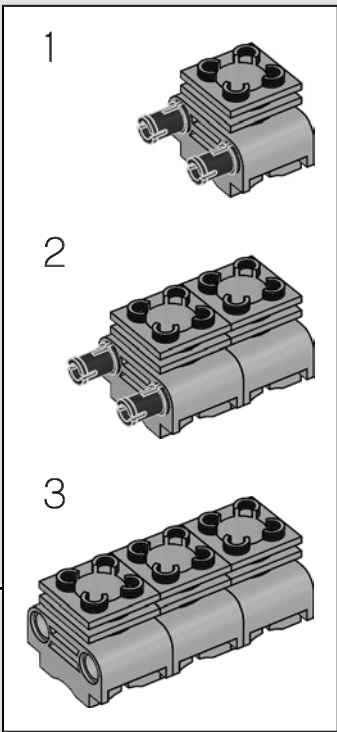

42

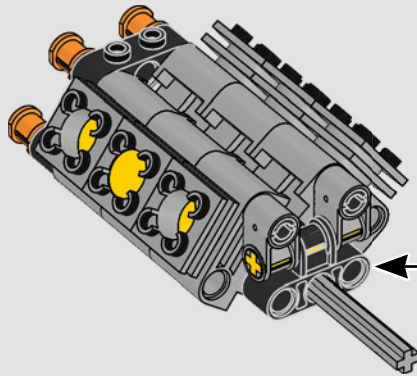
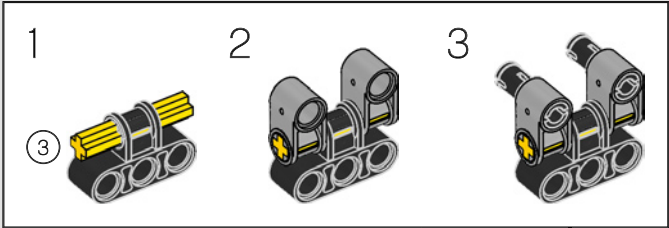
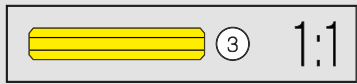

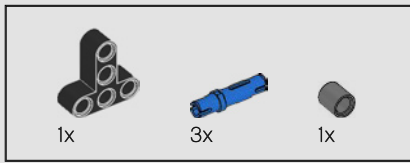

43

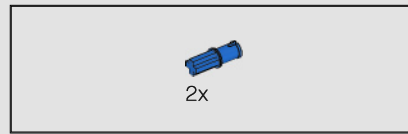
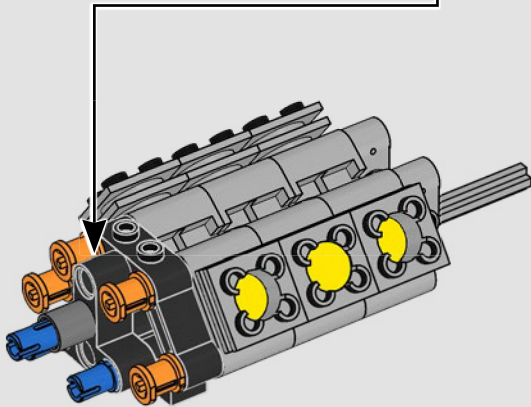
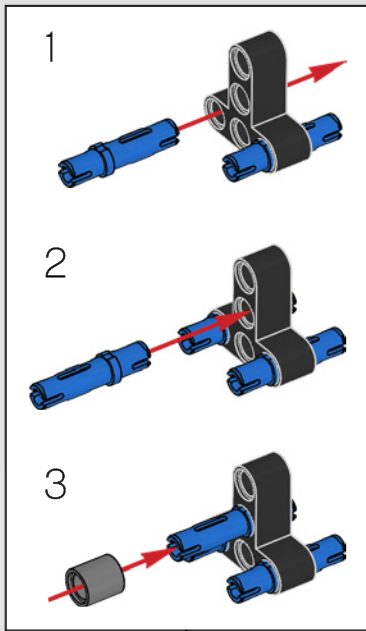

44

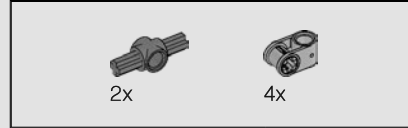
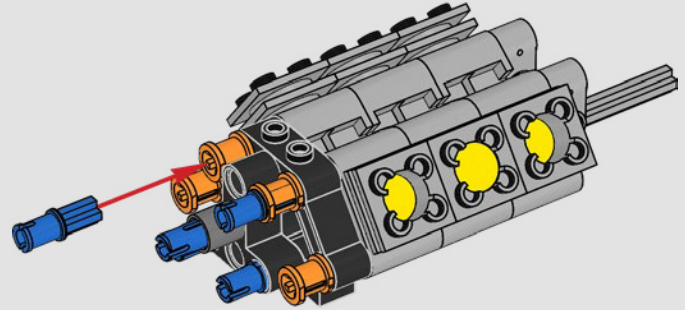

45

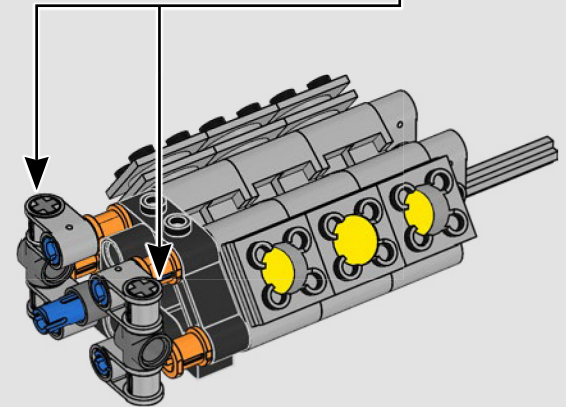
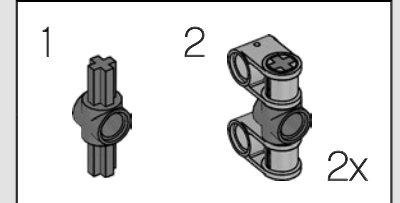

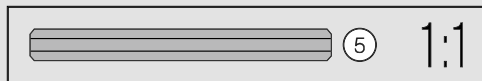
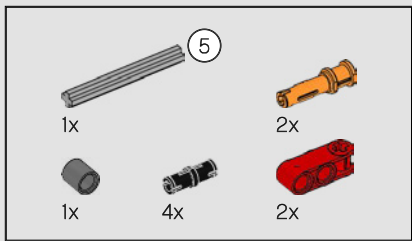

46

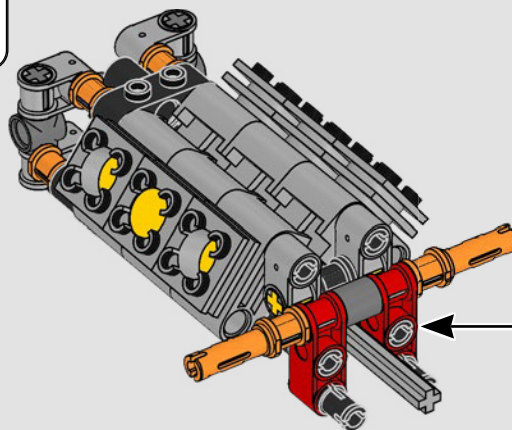
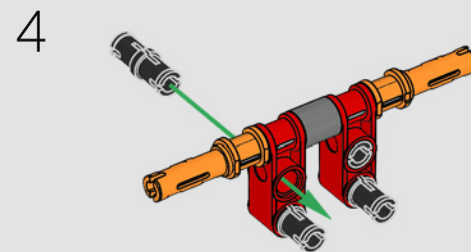
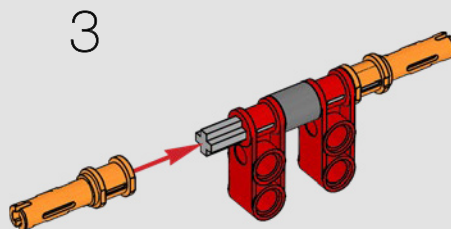
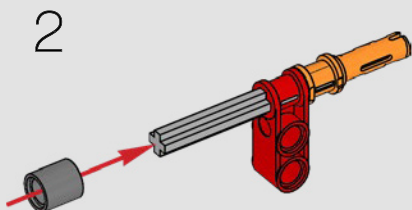
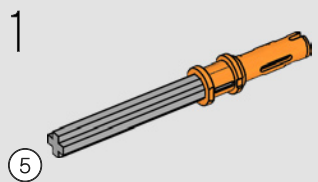

47

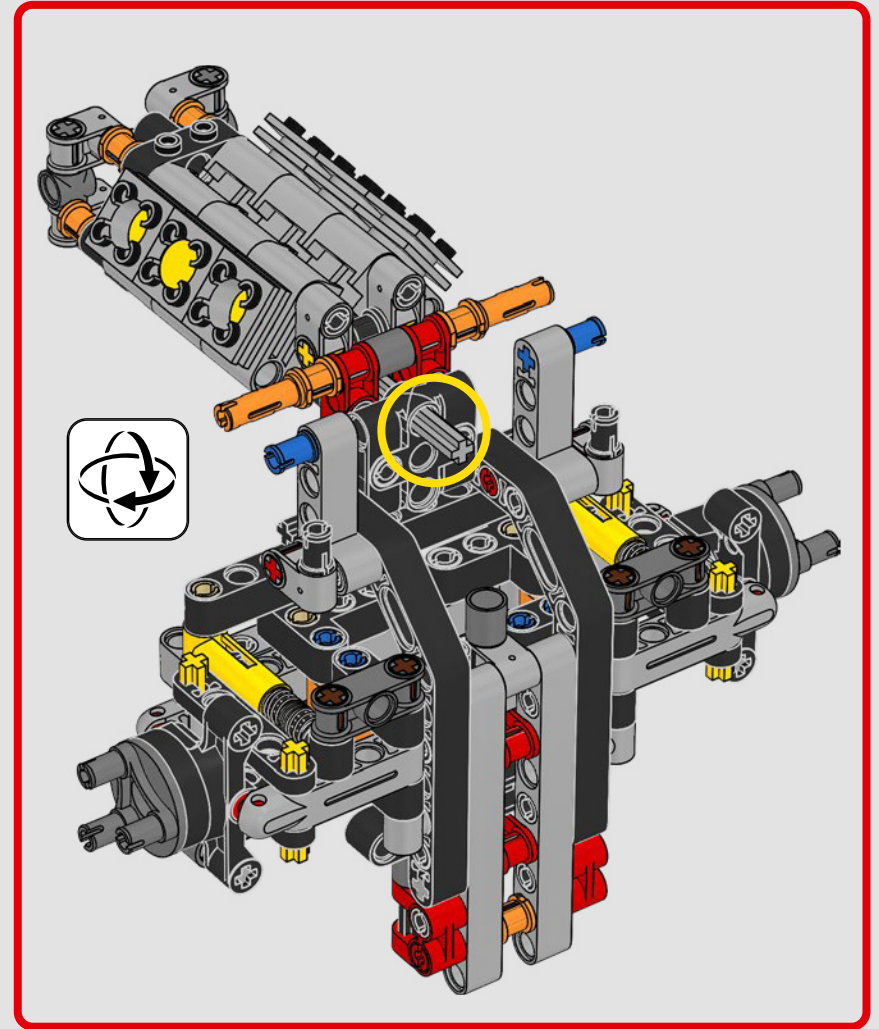
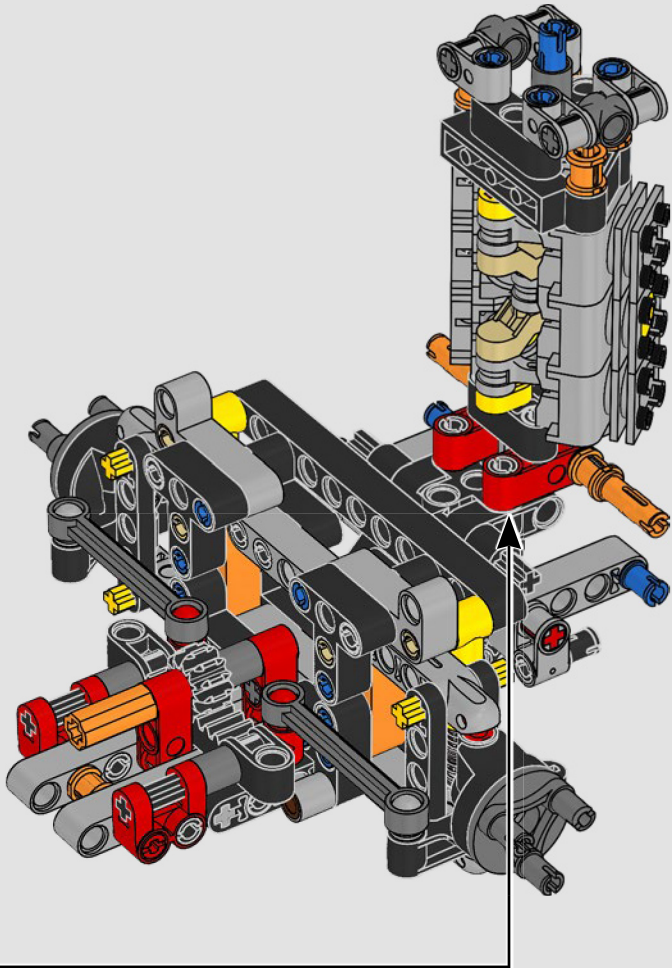



1x

48

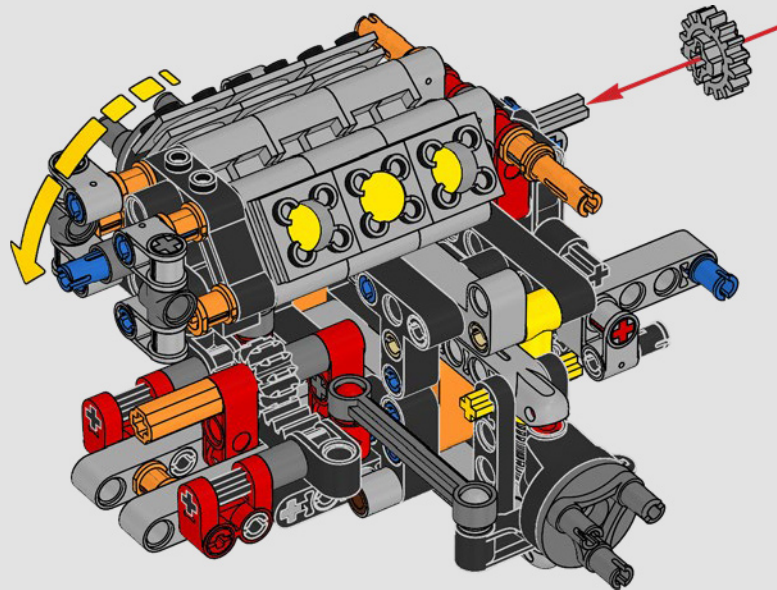

Under the hood is a 24-valve, 3.5L twin-turbo HO V6 with Ford's dual-fuel port and direct injection, and 10-speed automatic transmission.

Sous le capot se trouvent un moteur V6 3,5 l HO biturbo à 24 soupapes avec le système d'injection directe dans l'orifice d'admission de Ford, ainsi qu'une transmission automatique à 10 rapports.

Debajo del cofre está el motor de gran salida V6 doble turbo de 24 válvulas y 3,5 l equipado con el sistema de inyección directa y de combustible en puerto de Ford y la transmisión automática de 10 velocidades.

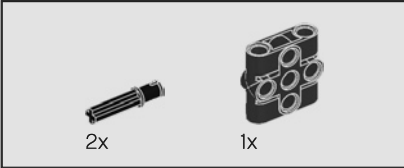
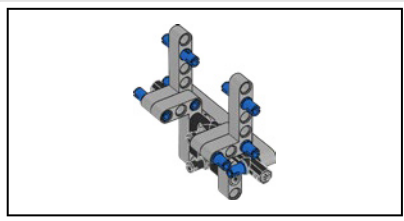

49

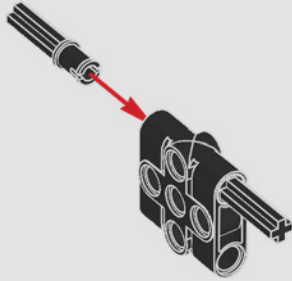

50

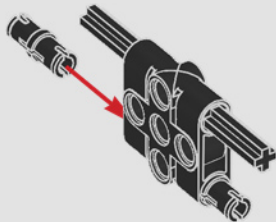

51

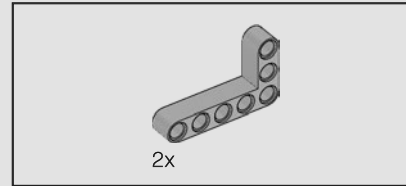
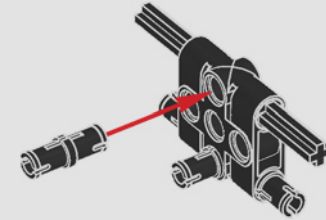

52

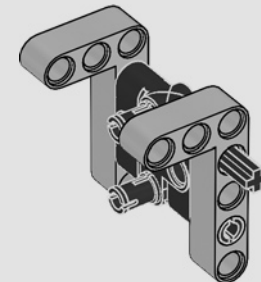

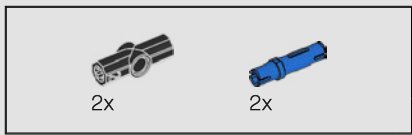

53

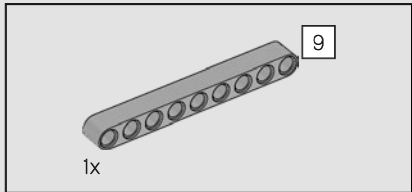
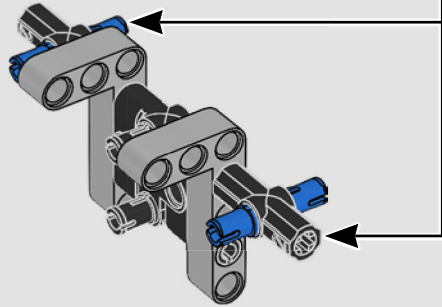
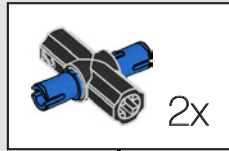

54

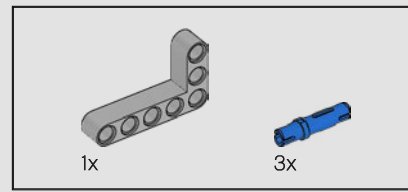
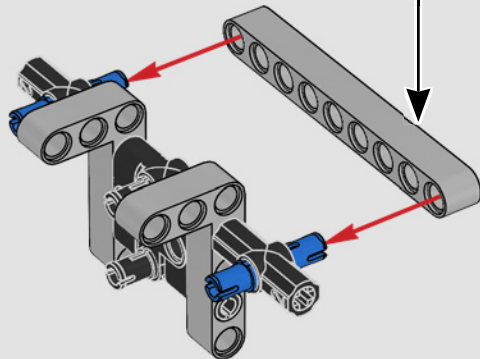
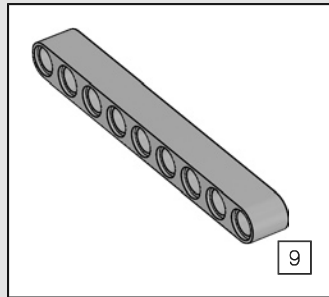

55

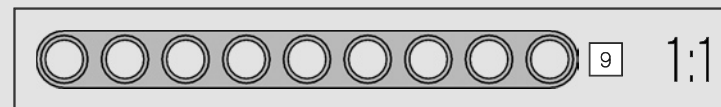
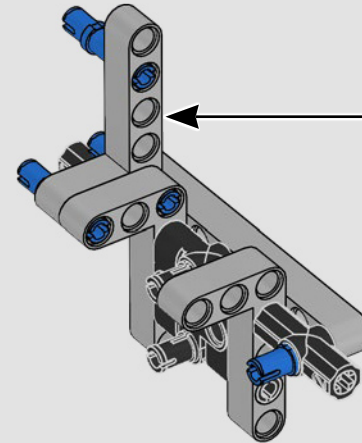
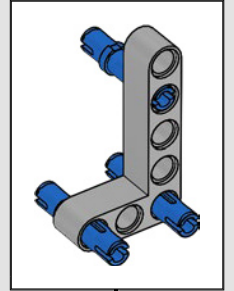

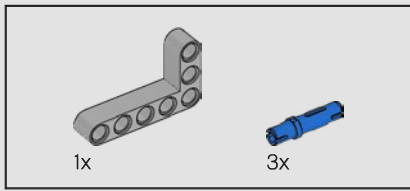

56

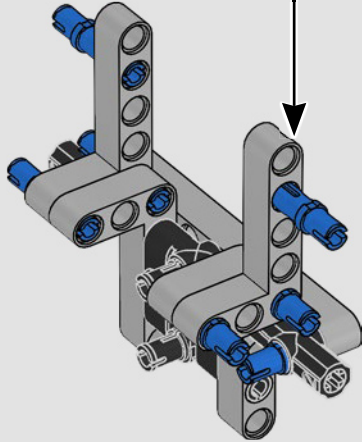
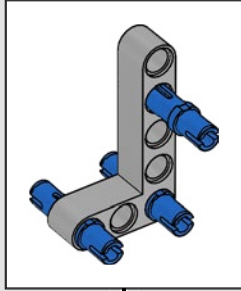

57

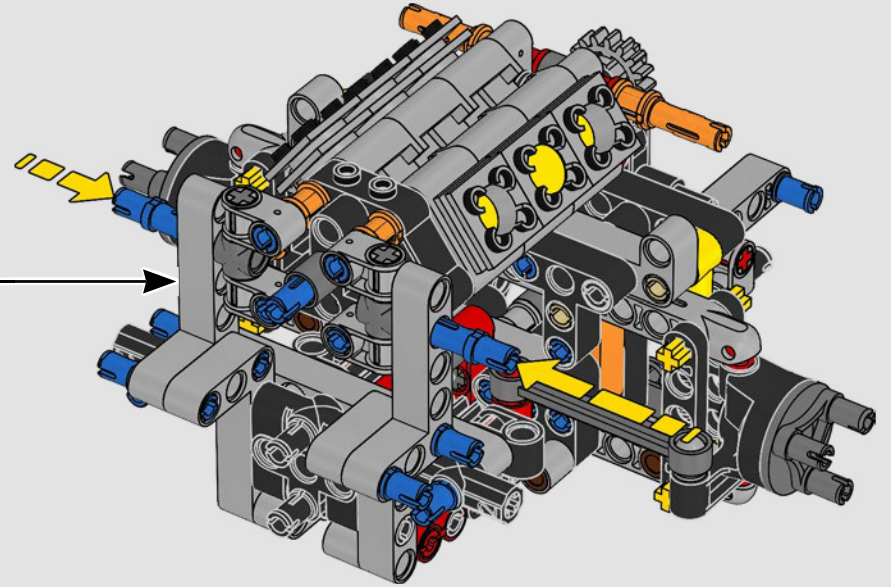

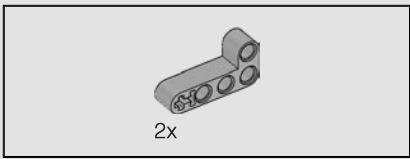

58

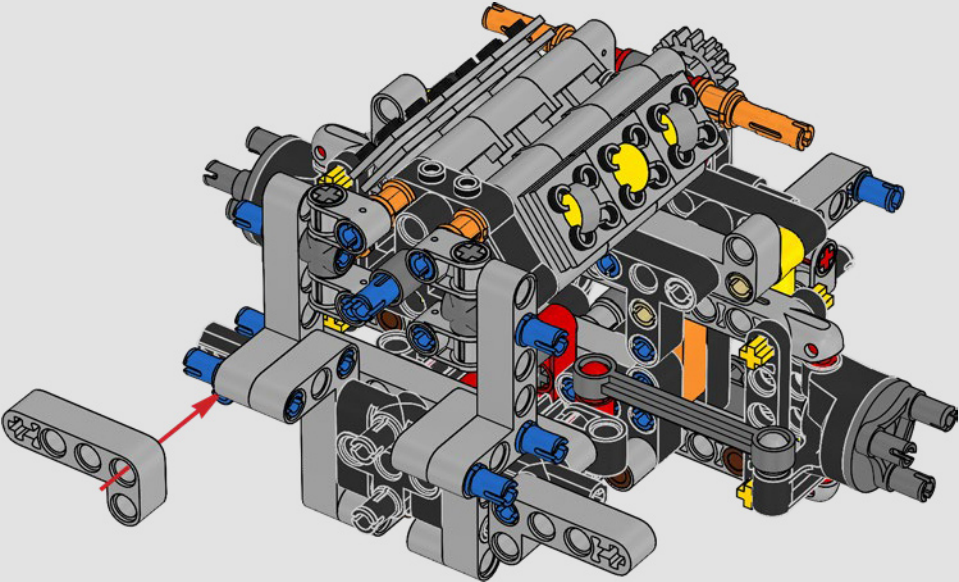

59

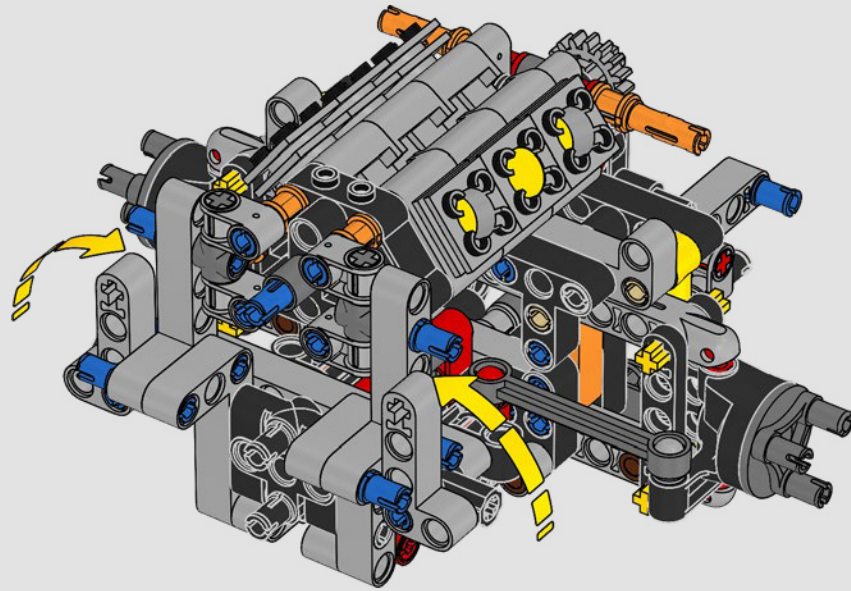

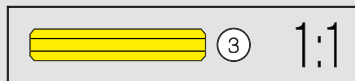
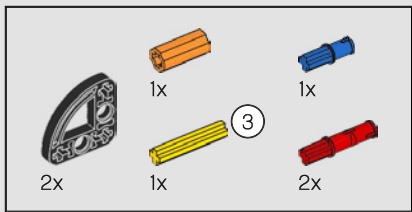

60

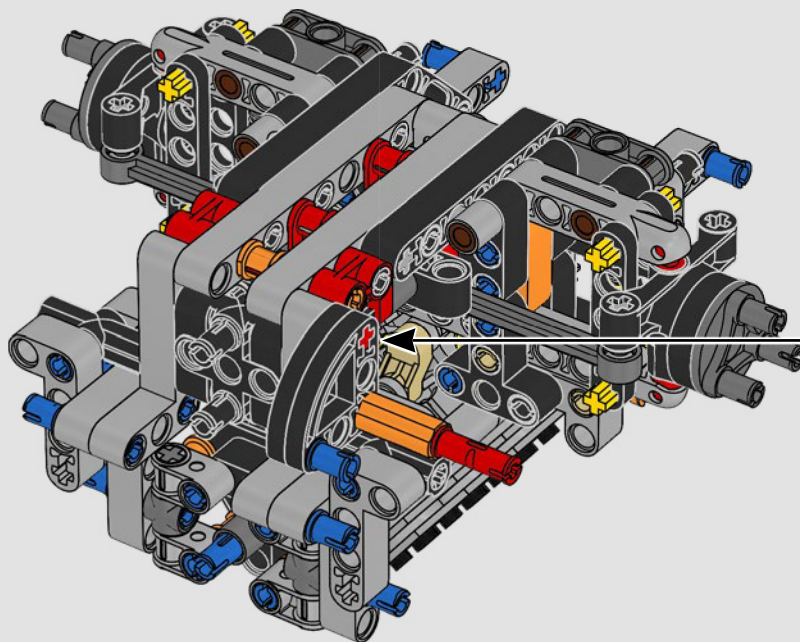
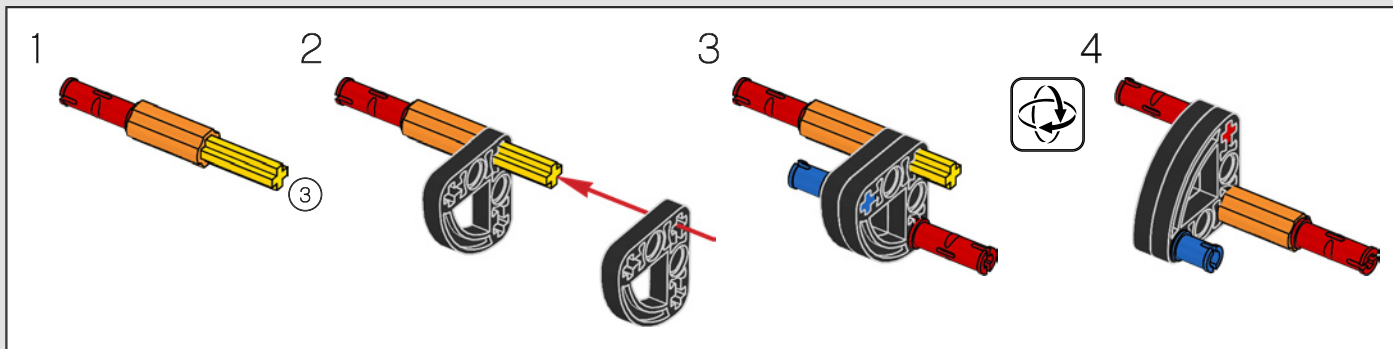

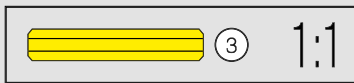
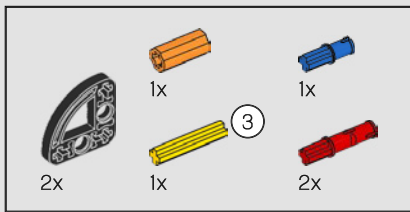

61

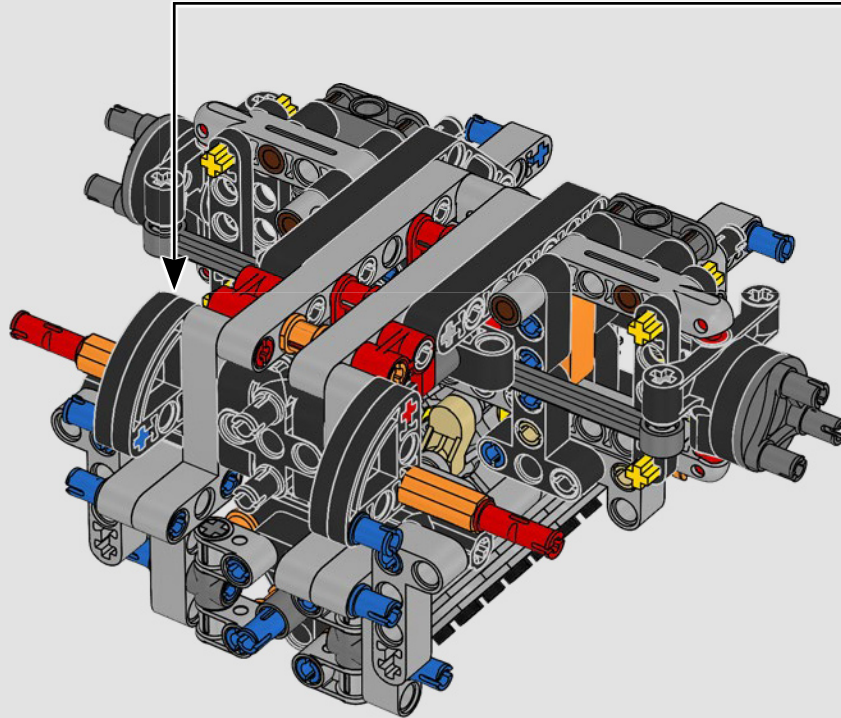
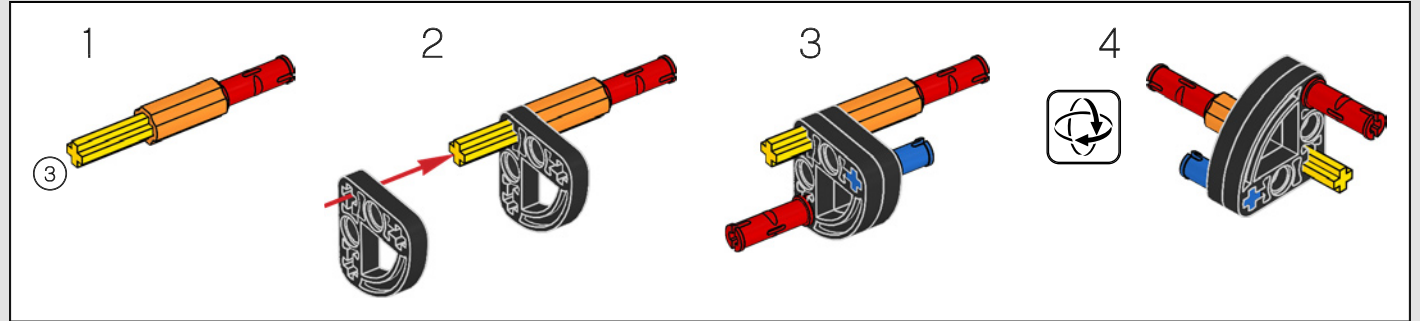

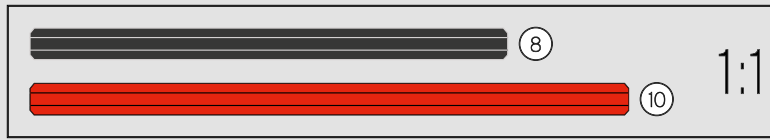
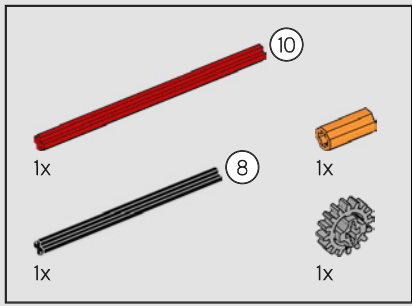

62

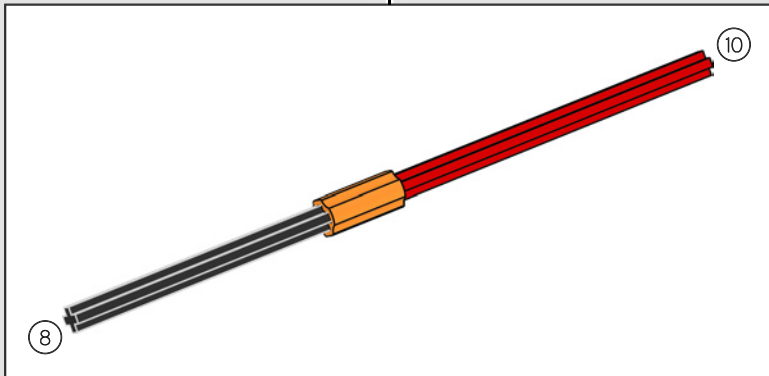
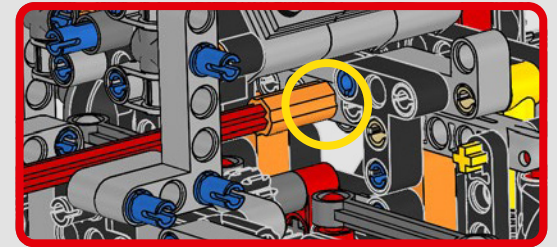
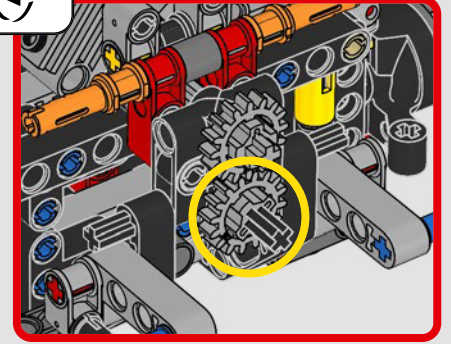
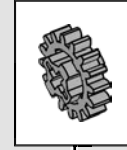
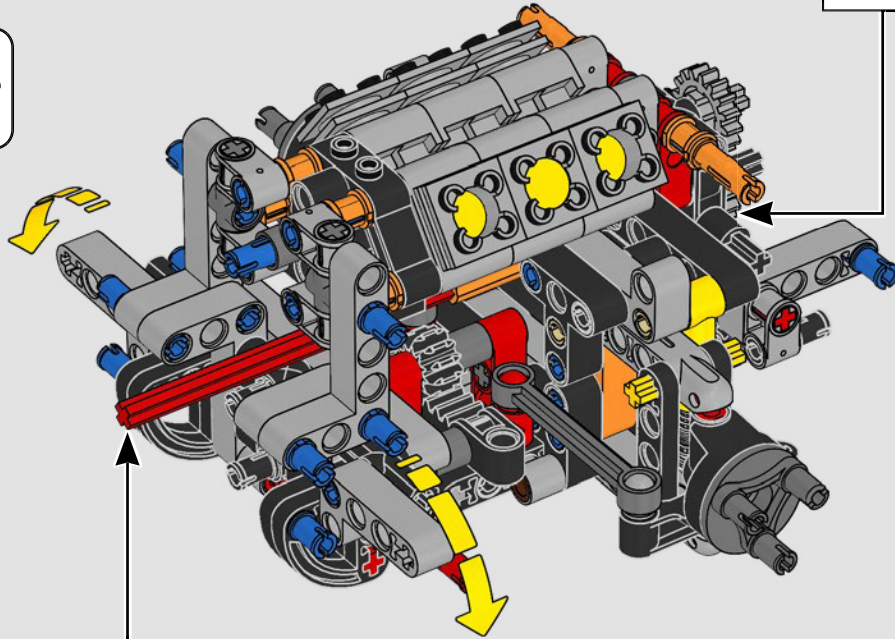

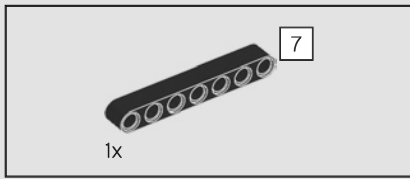

63

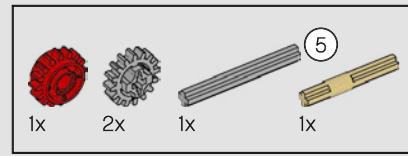
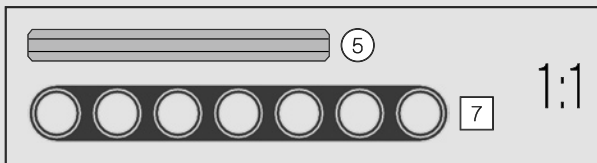
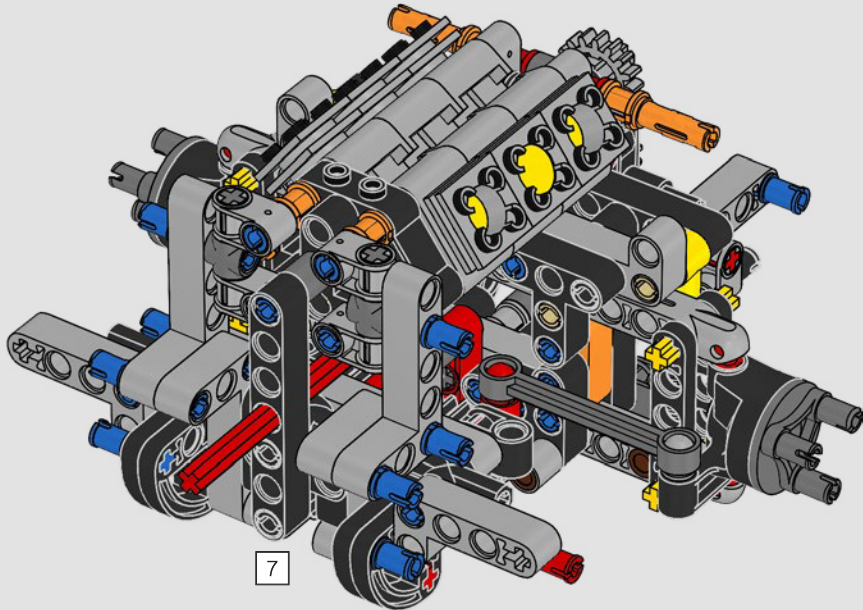

64

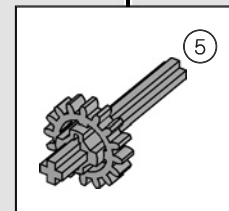
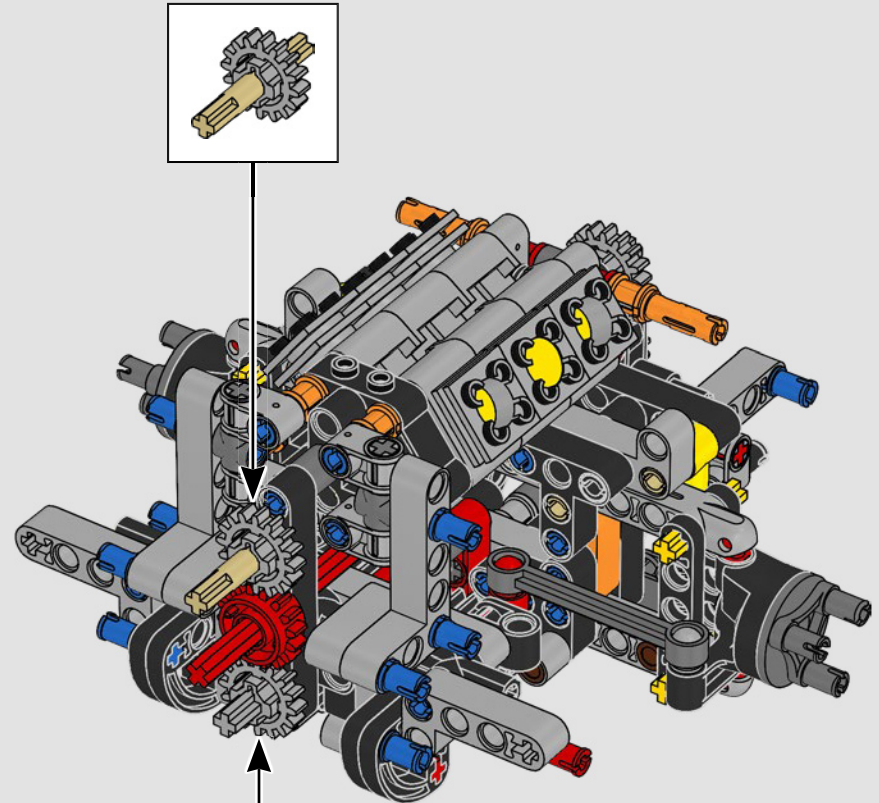

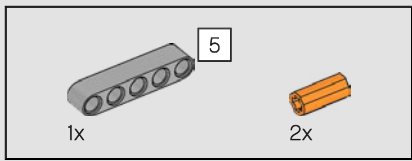

65

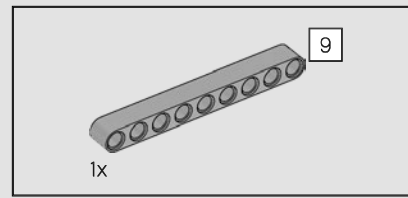
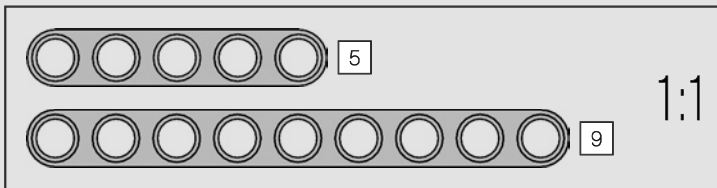
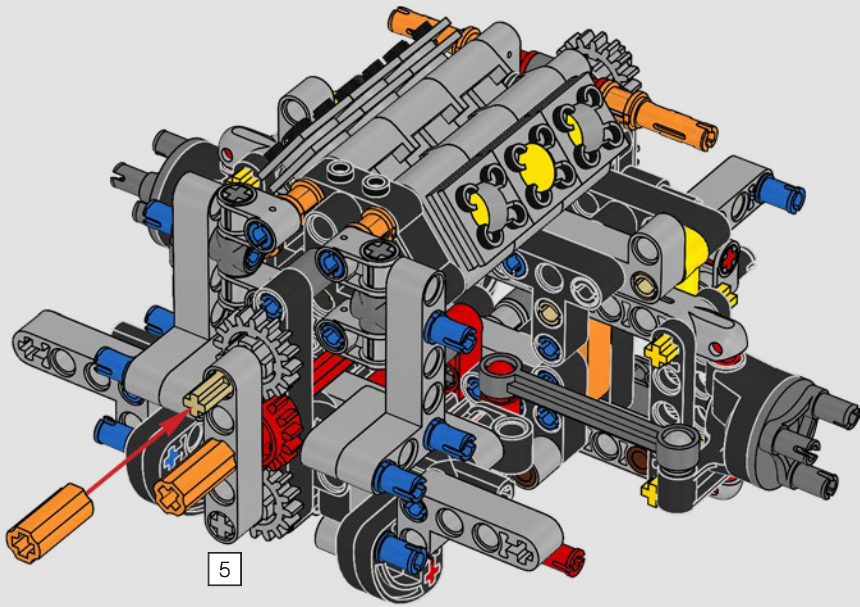

66

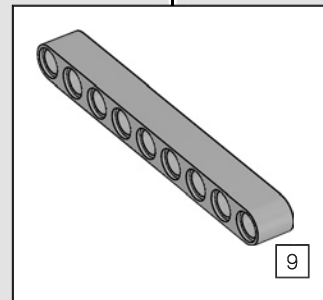
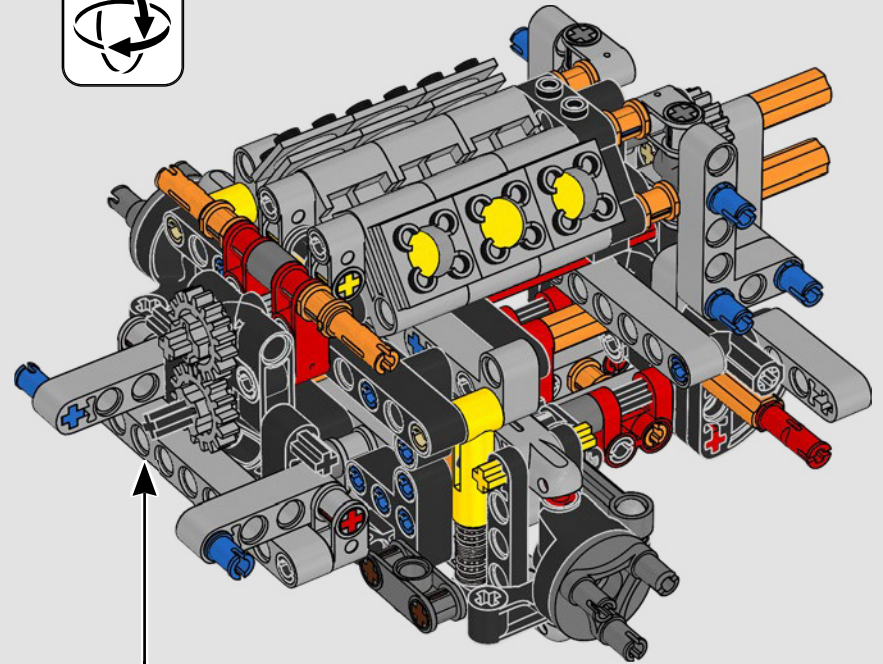
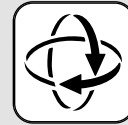

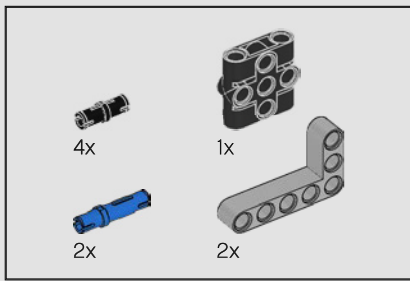

67

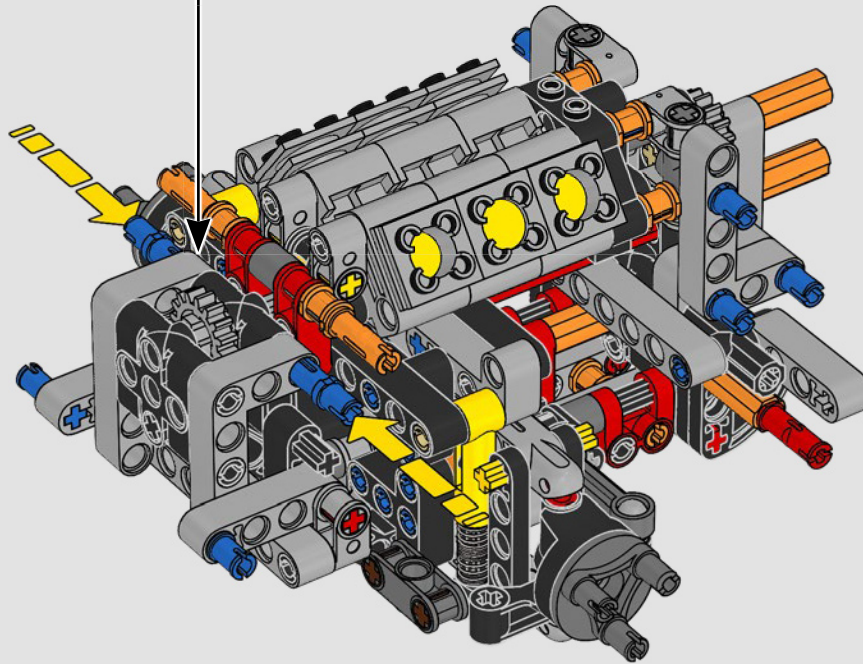
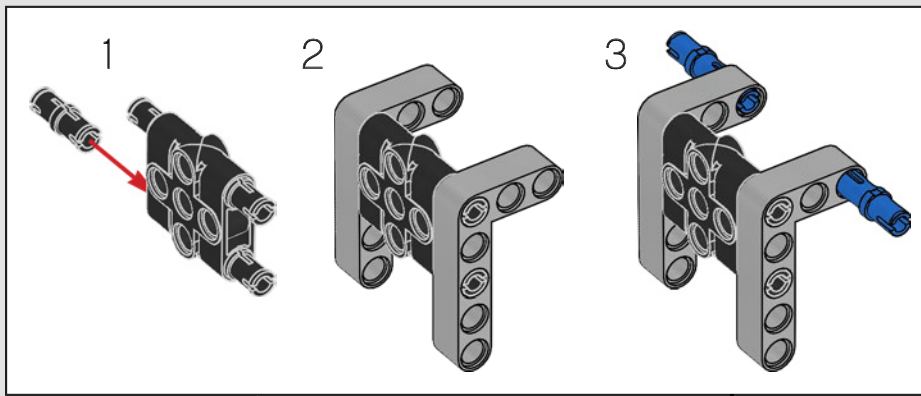

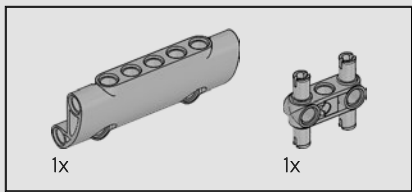

68

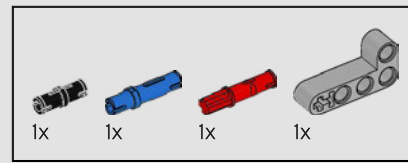
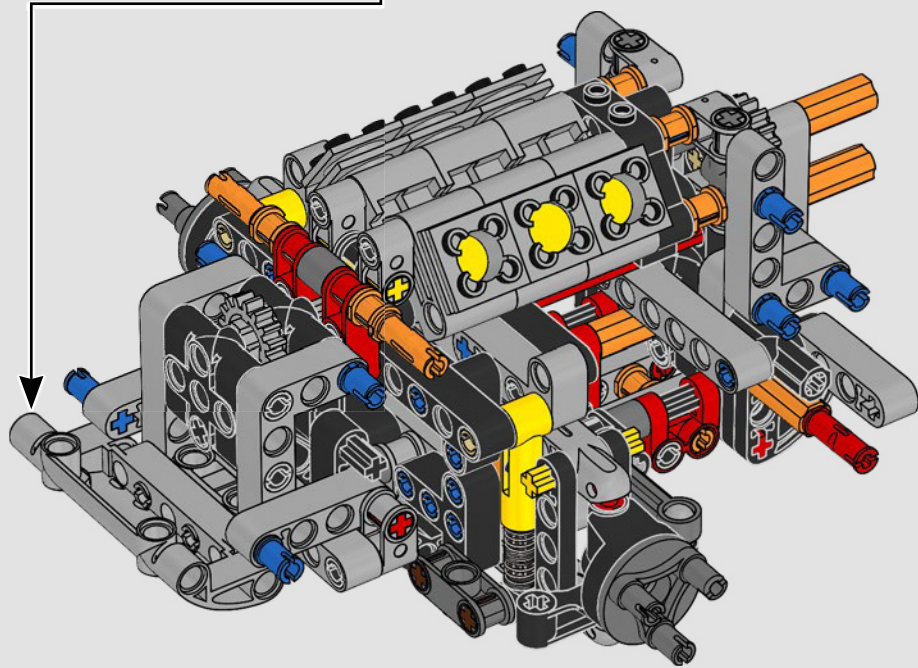
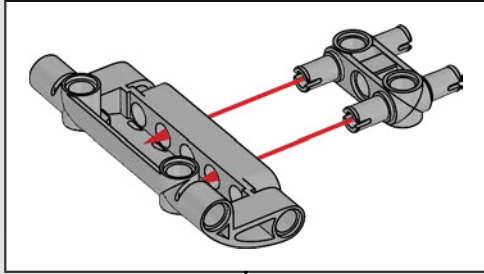

69

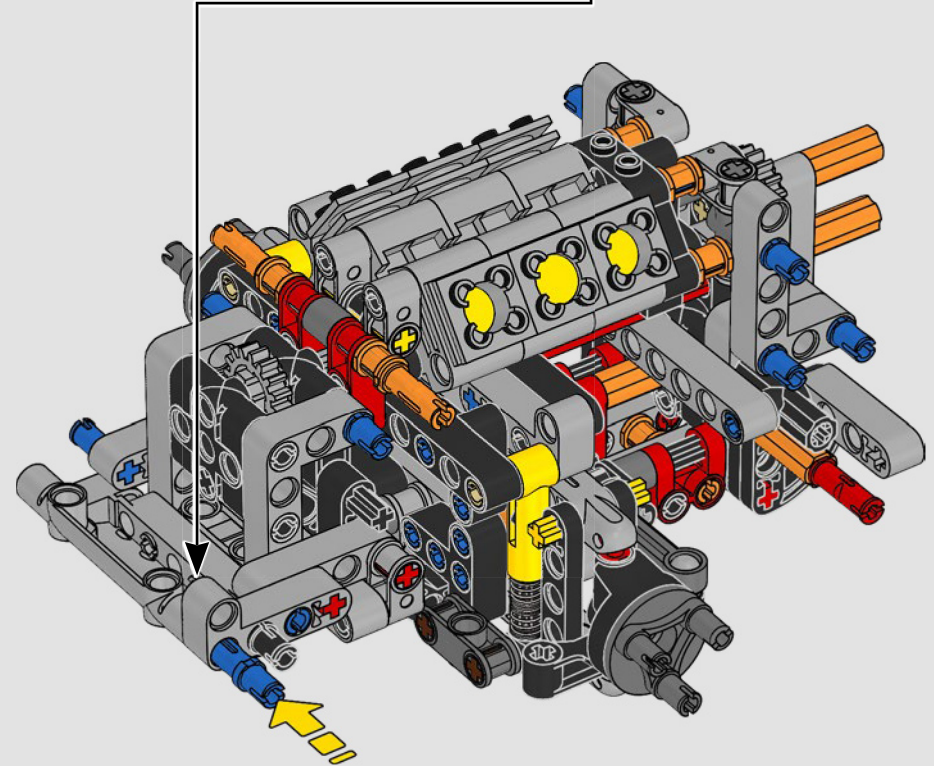
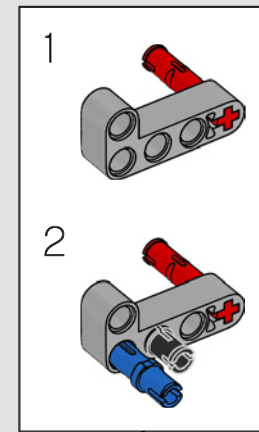

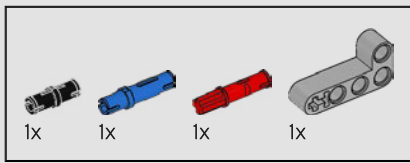

70

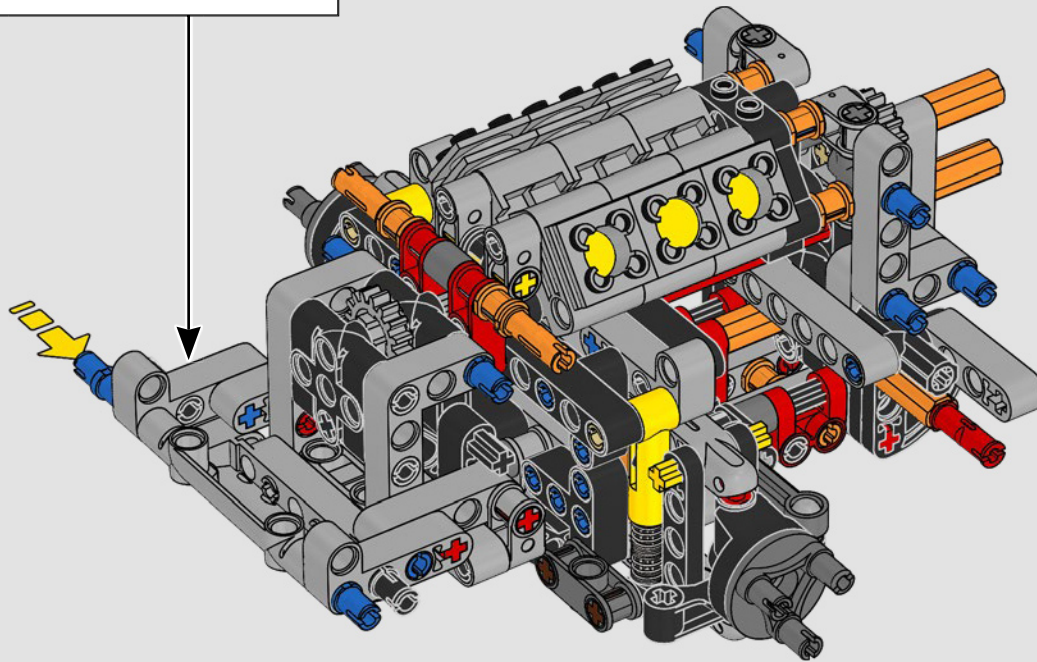
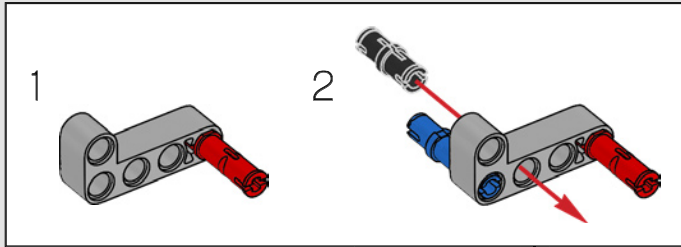

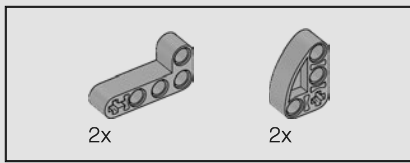

71

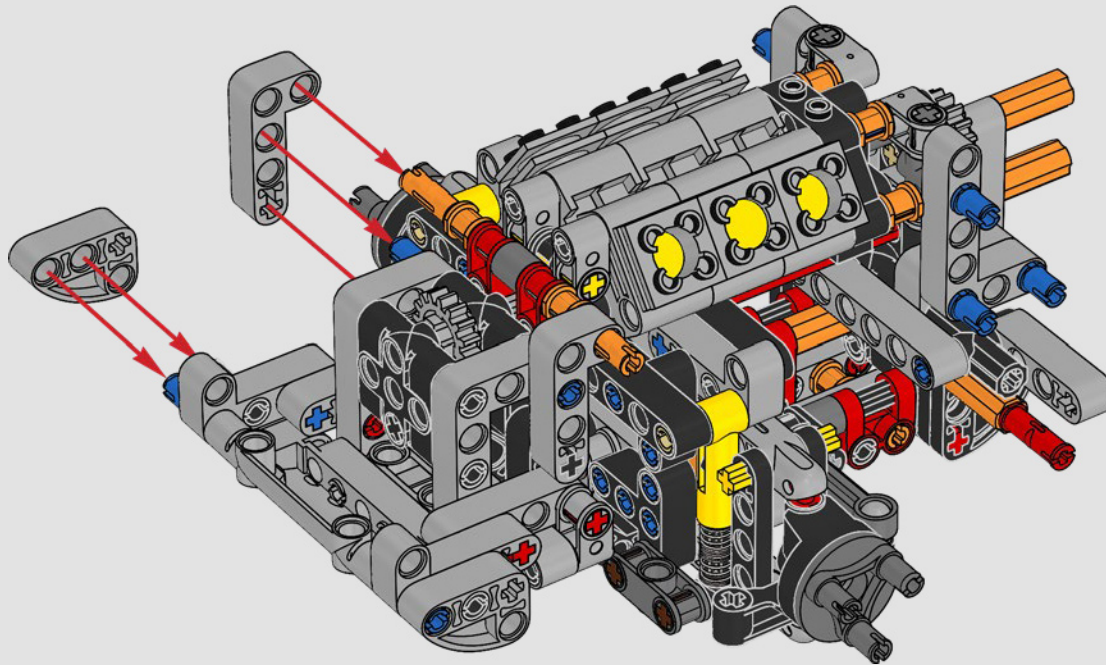

Optimized for off-road use, the Raptor is fitted with four-wheel drive as standard.

Optimisée pour la conduite hors route, la Raptor est équipée de quatre roues motrices.

Optimizada para la conducción fuera de la carretera, la Raptor está equipada de serie con tracción en las cuatro ruedas.

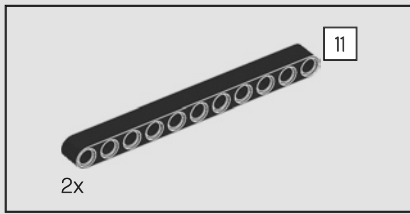

72

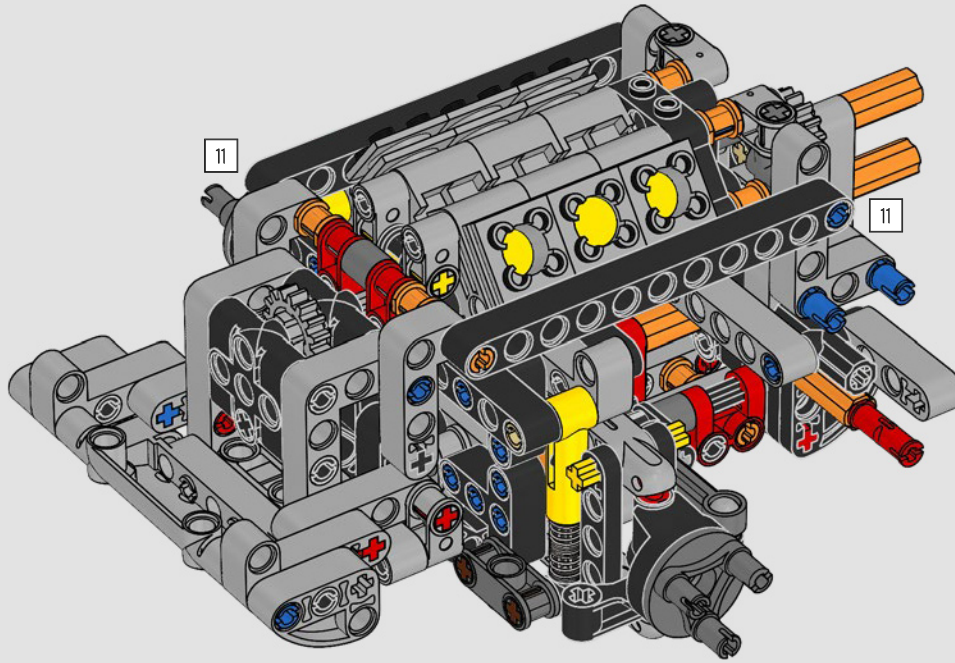

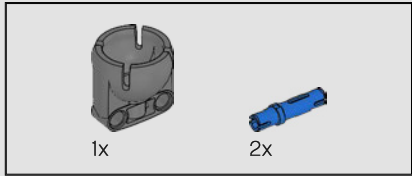
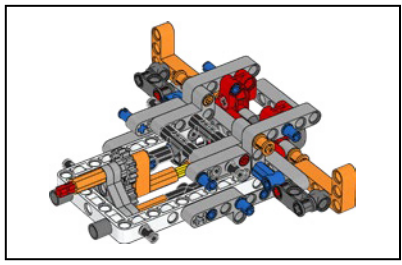

73

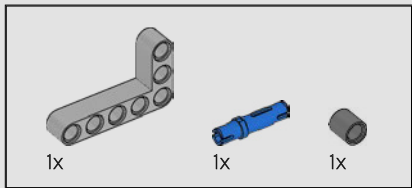
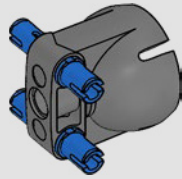

74

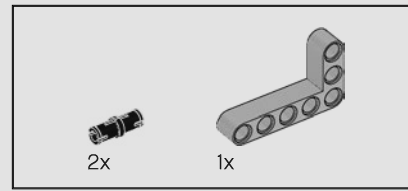
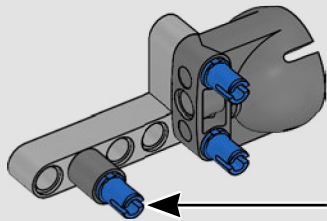
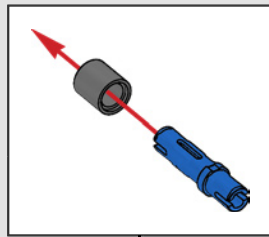

75

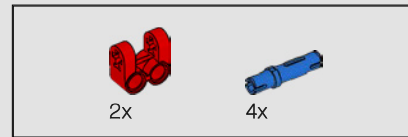
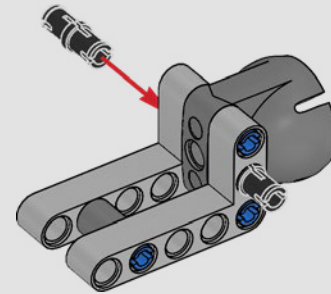

76

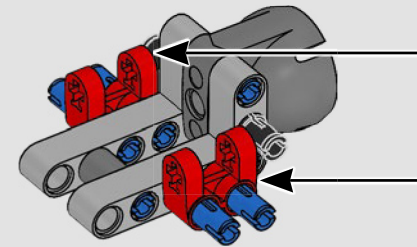
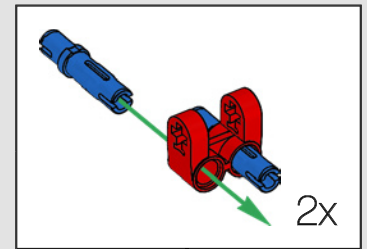

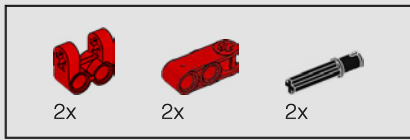

77

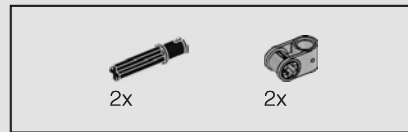
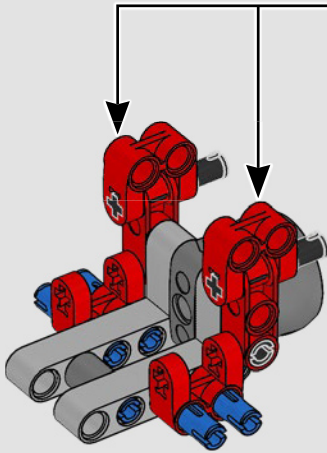
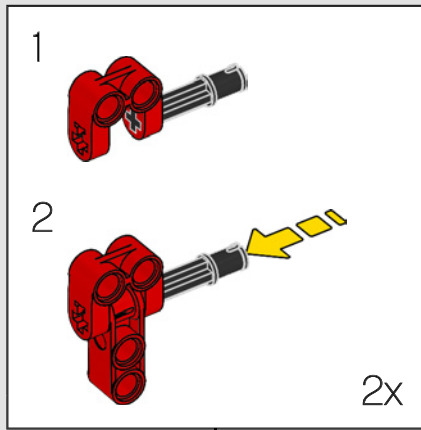

78

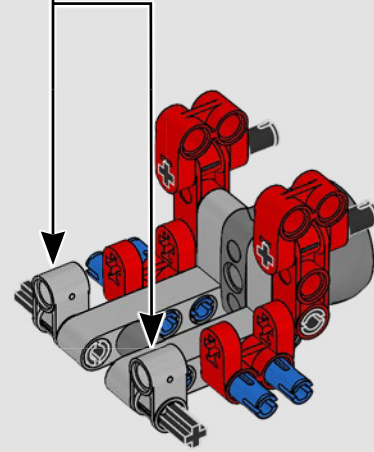
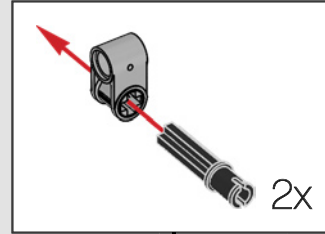

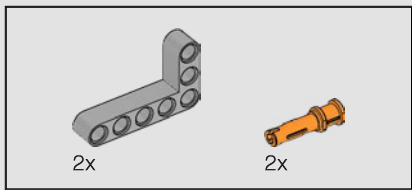

79

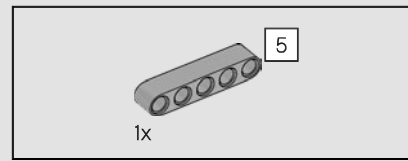
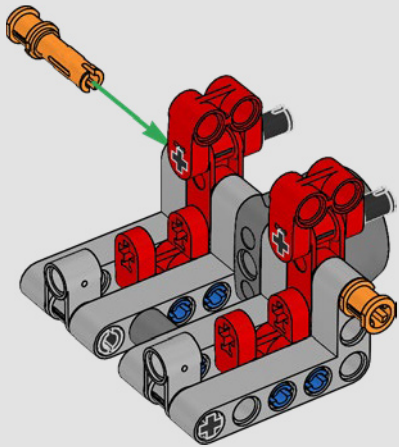

80

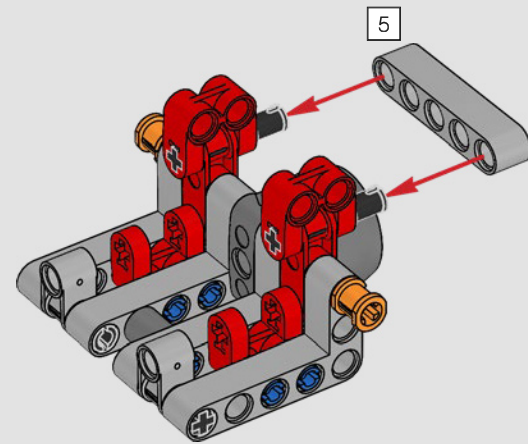

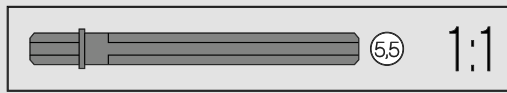
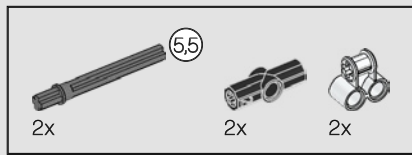

81

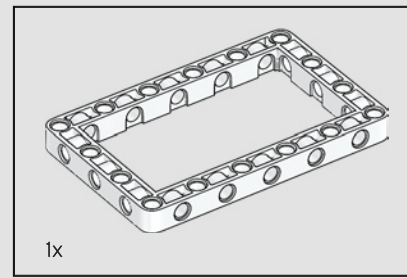
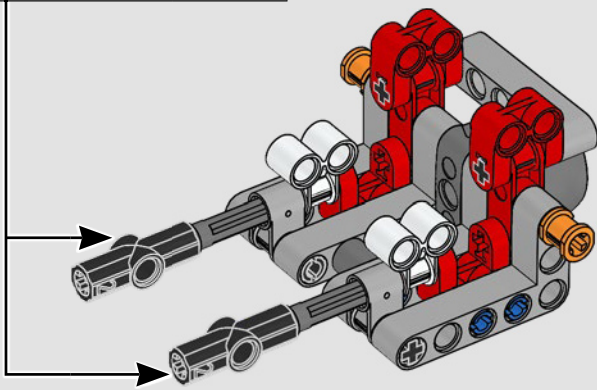
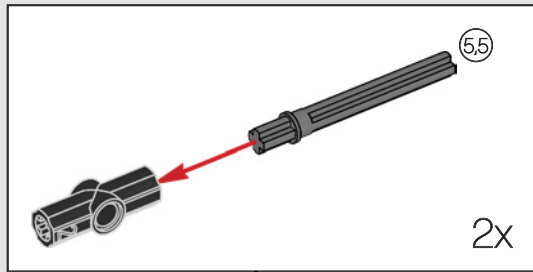

82

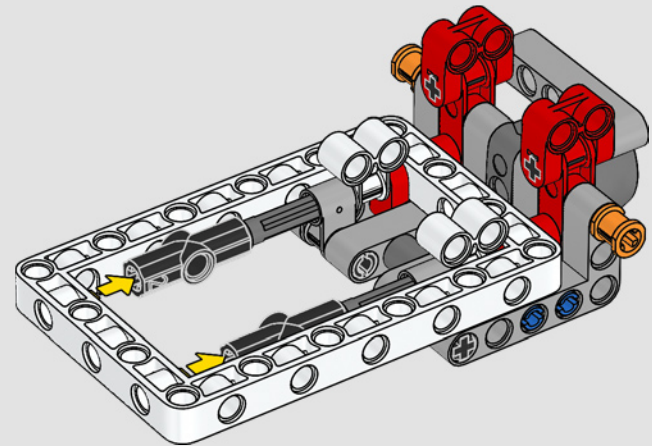

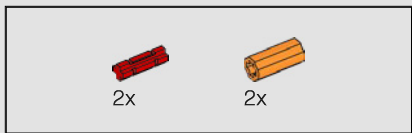

83

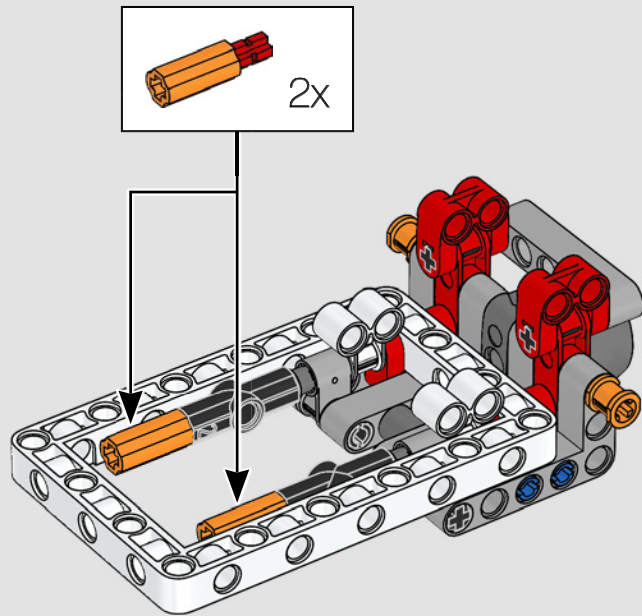

84

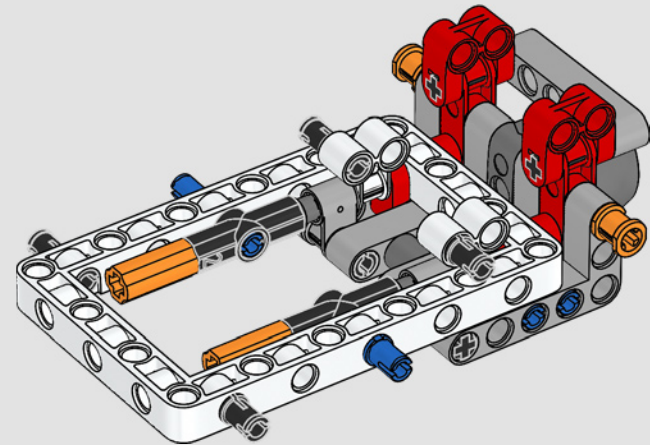

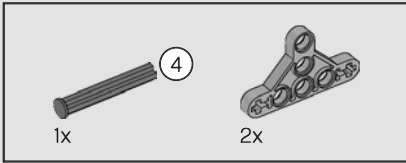
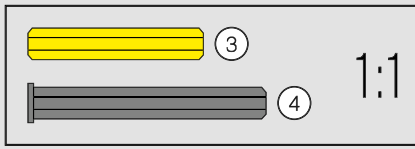
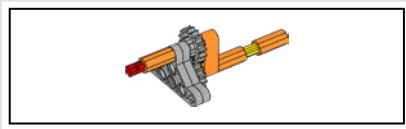

85

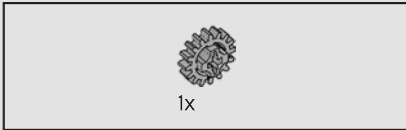
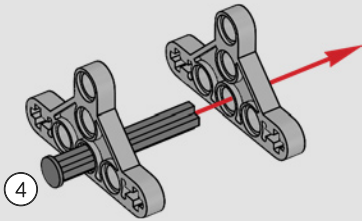

86

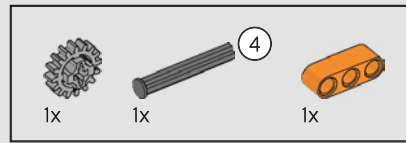
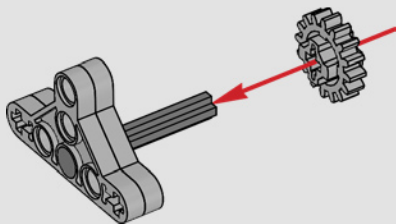

87

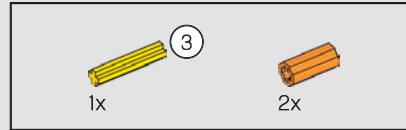
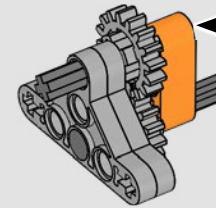
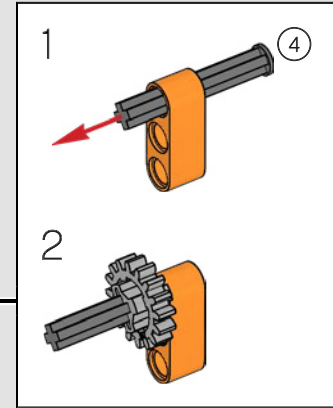

88

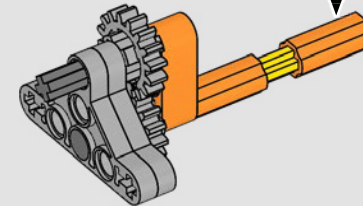
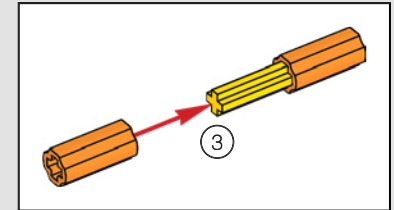

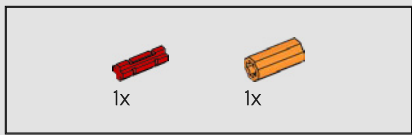

89

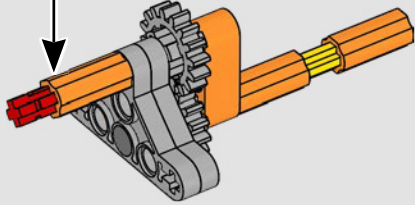
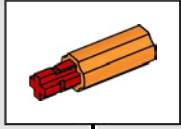

90

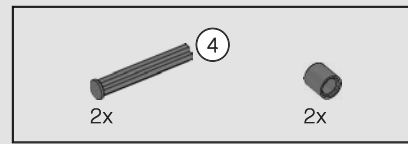
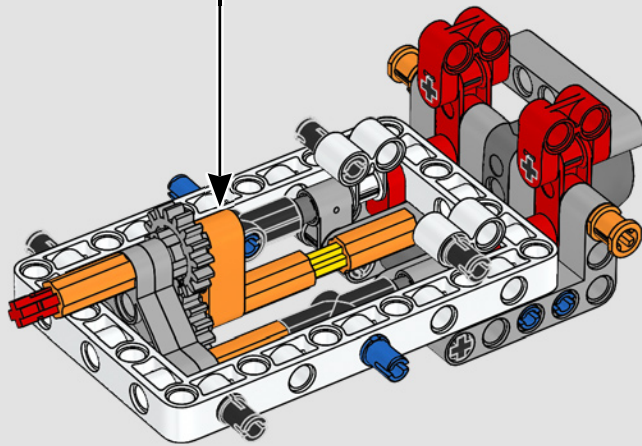

91

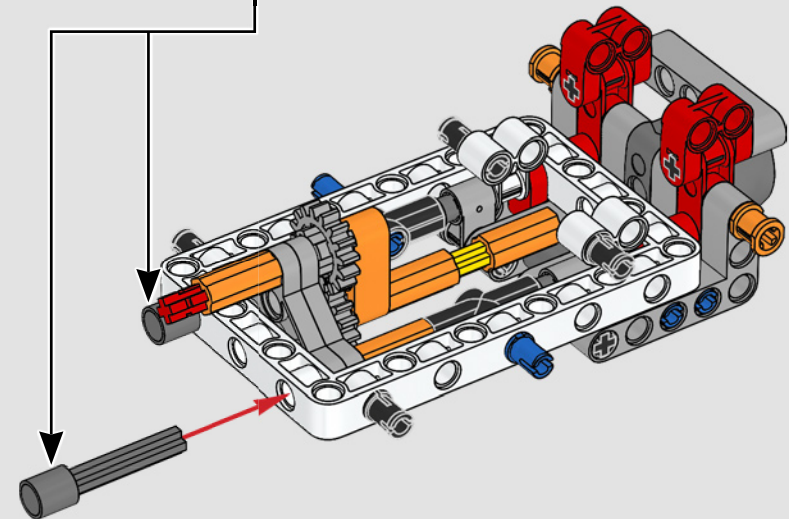
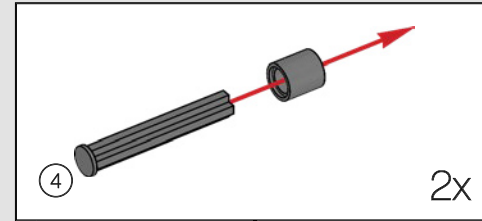
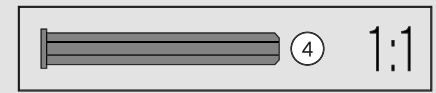

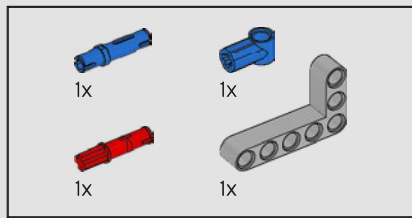

92

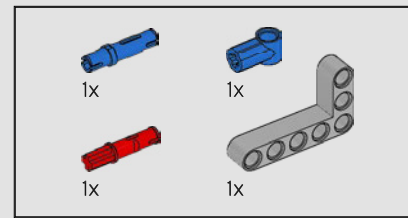
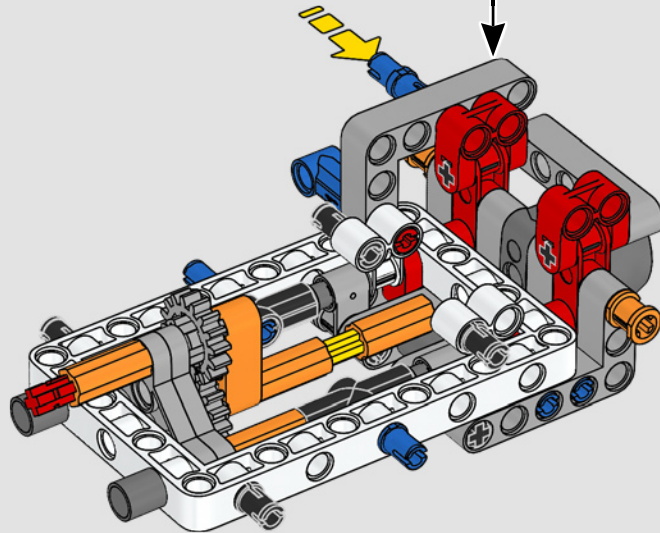
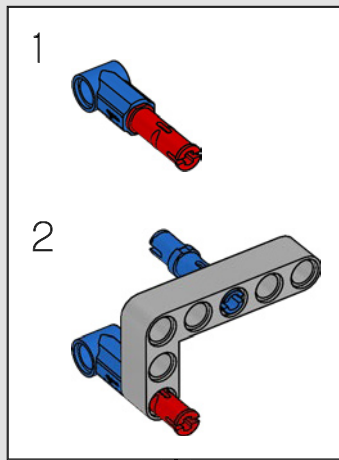

93

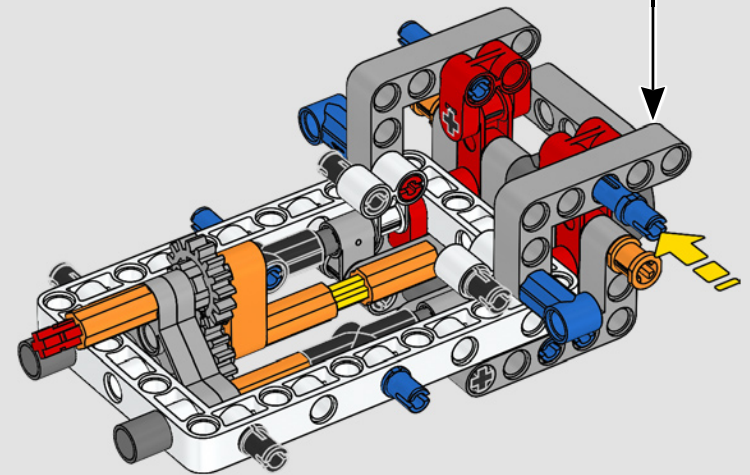
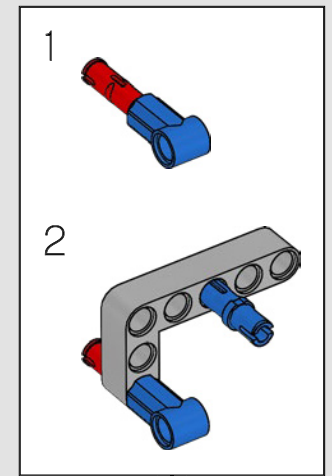

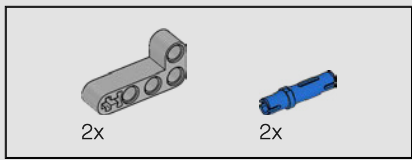

94

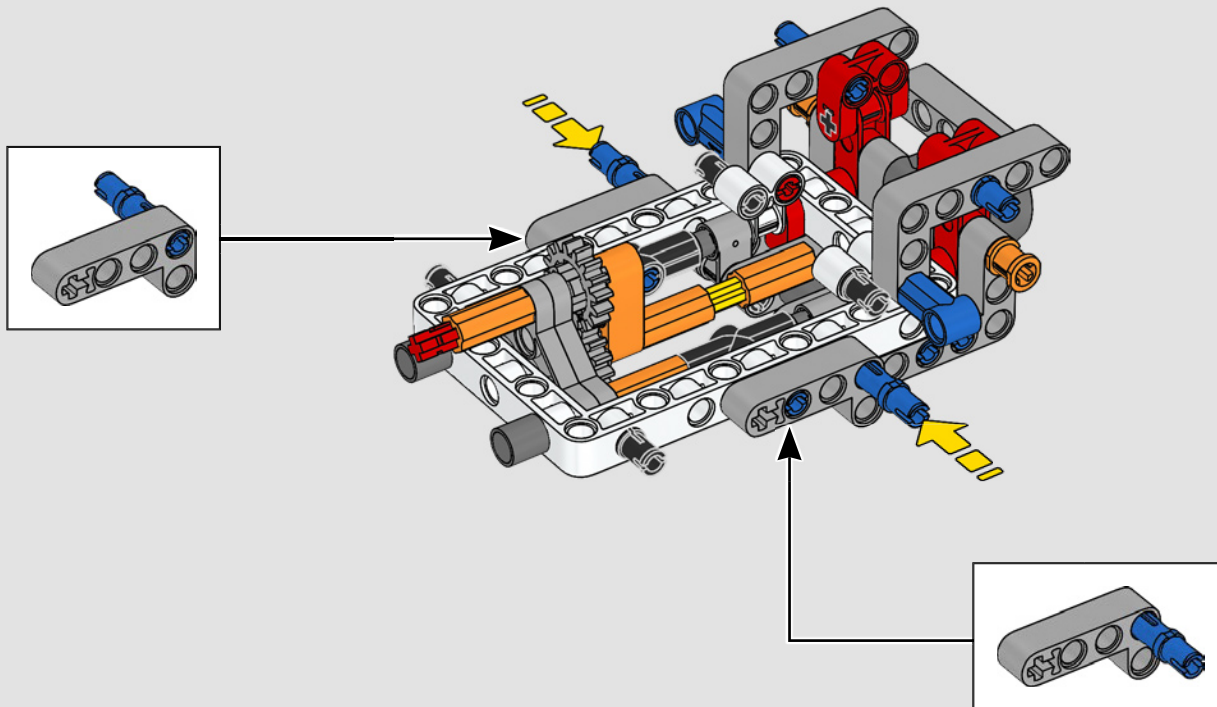

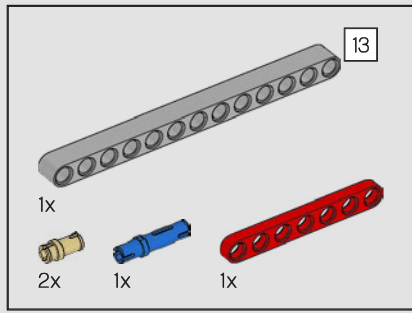

95

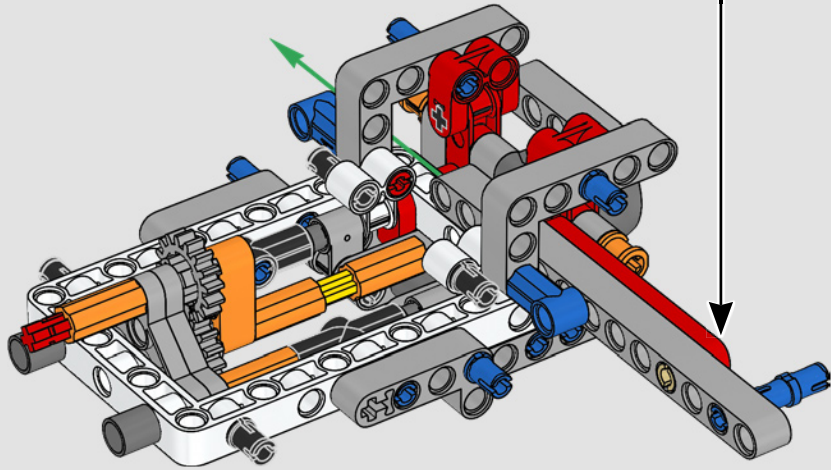
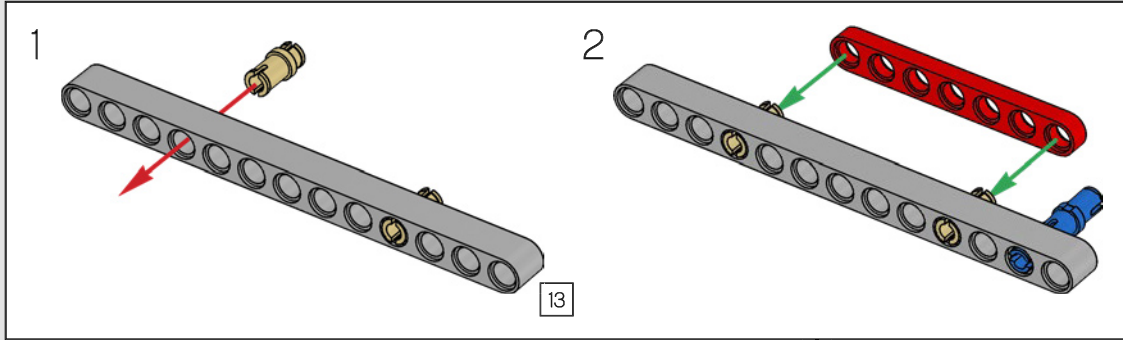
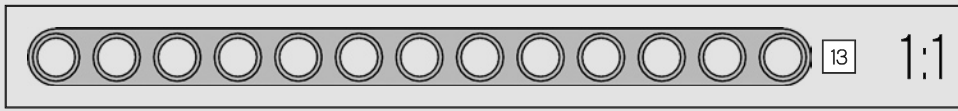

96

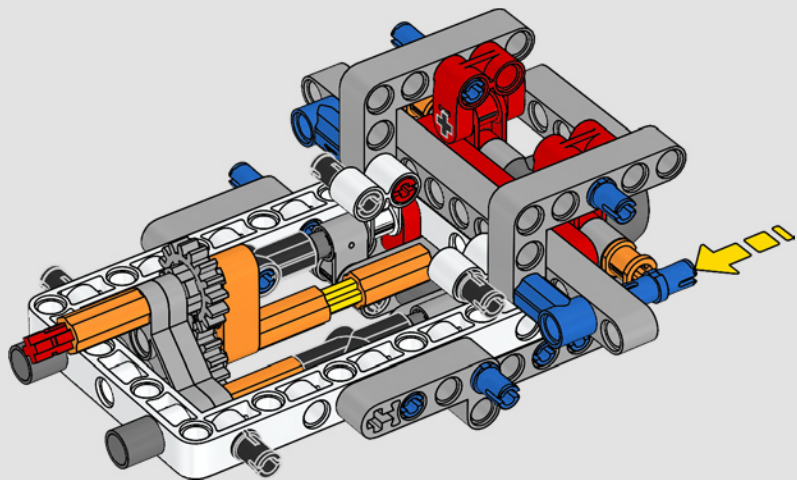

97

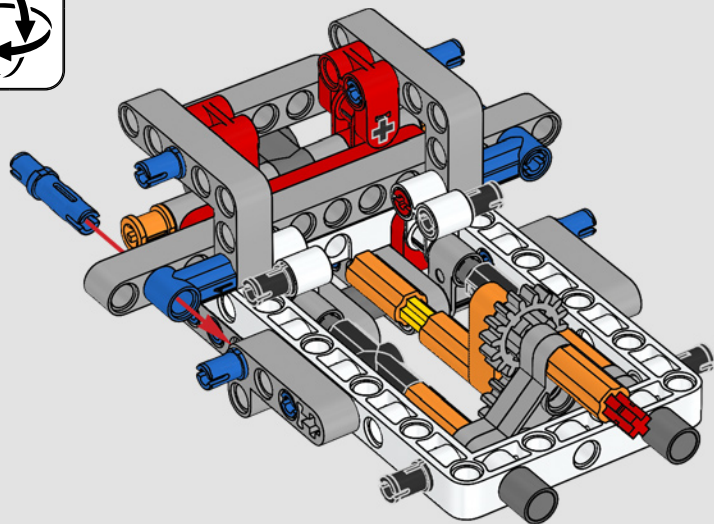

98

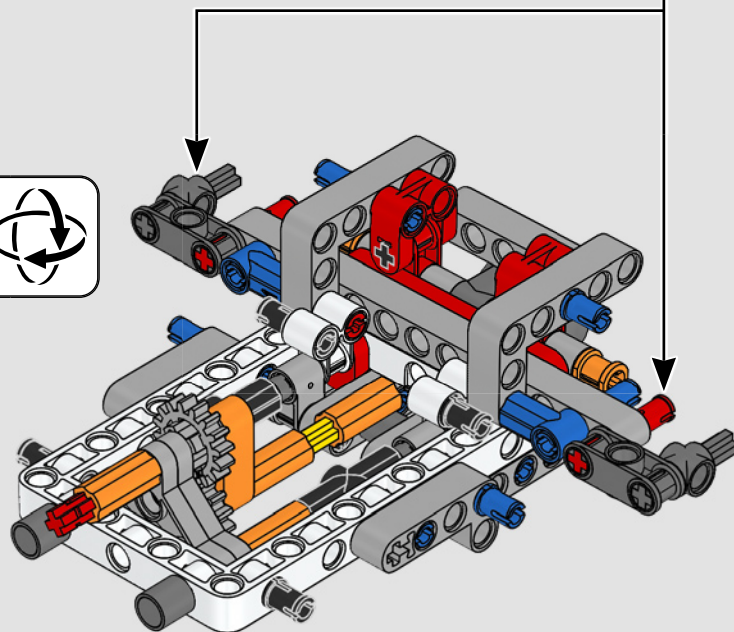
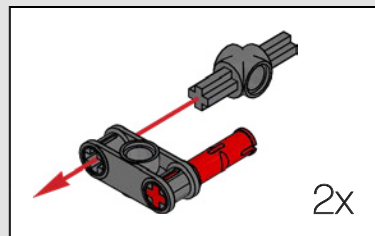

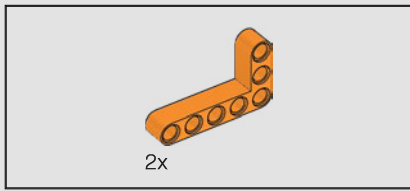

99

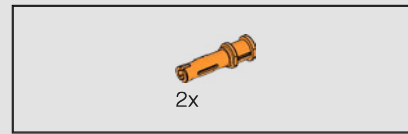
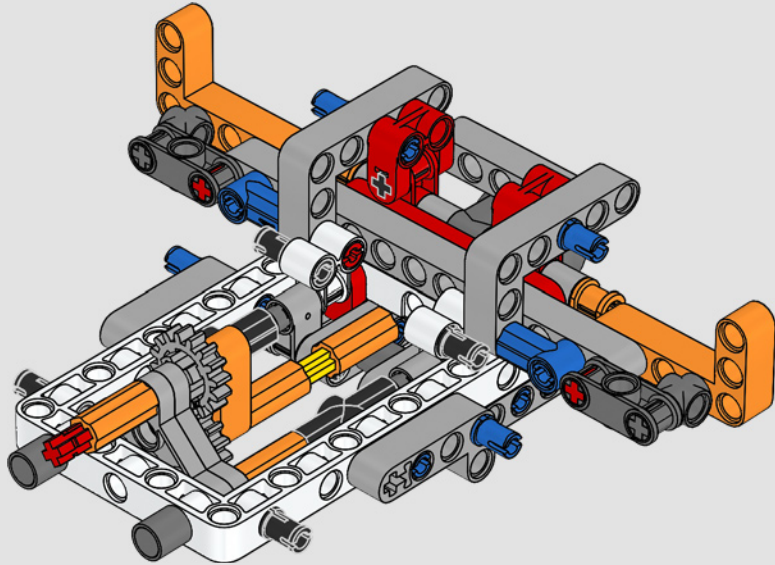

100

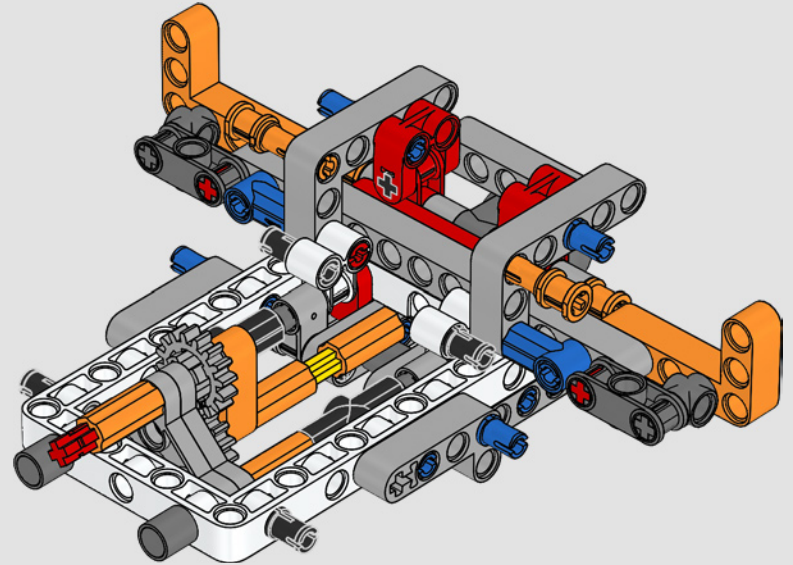

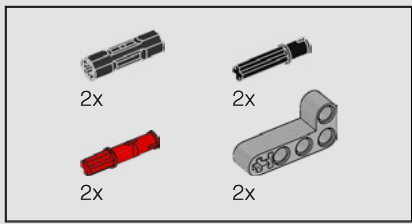

101

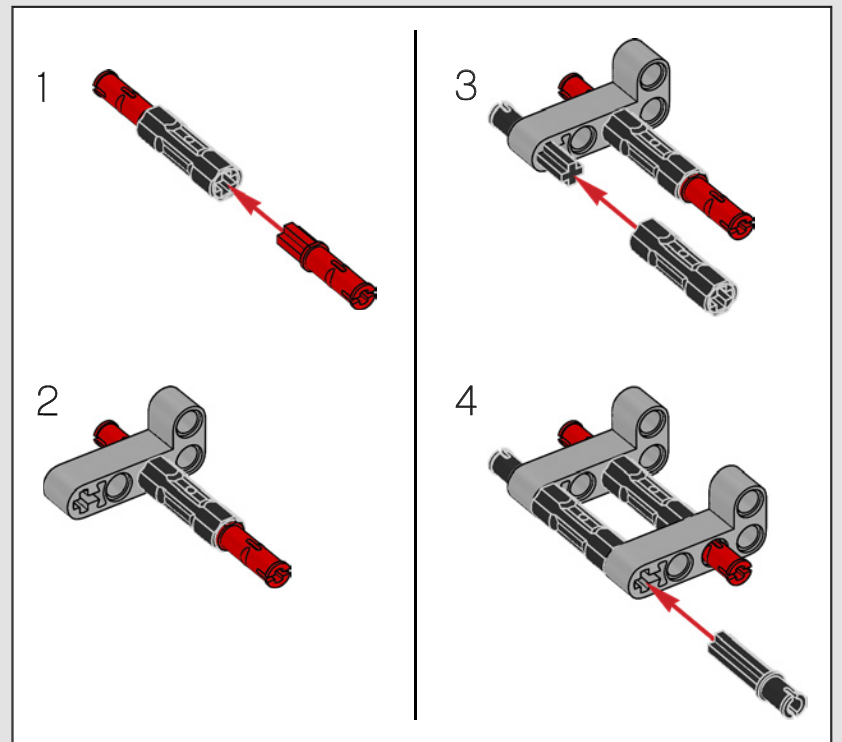
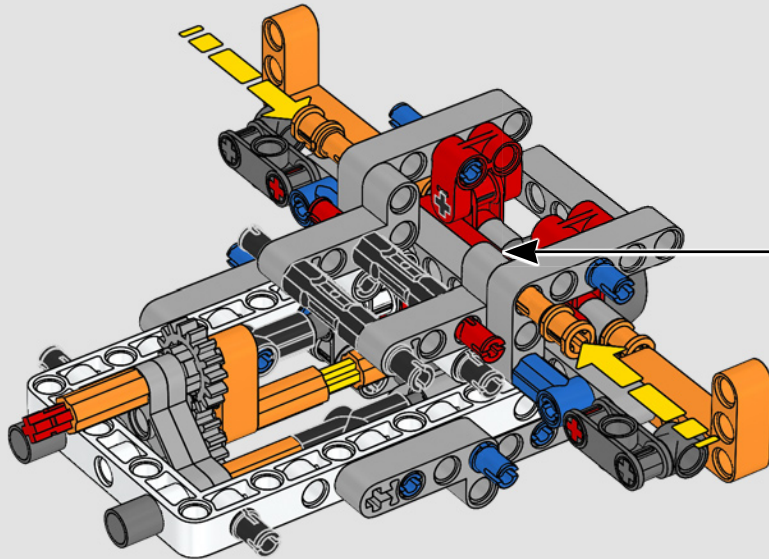

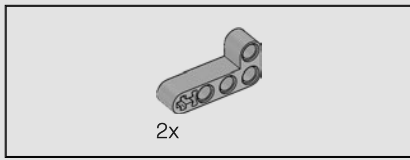

102

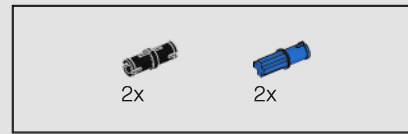
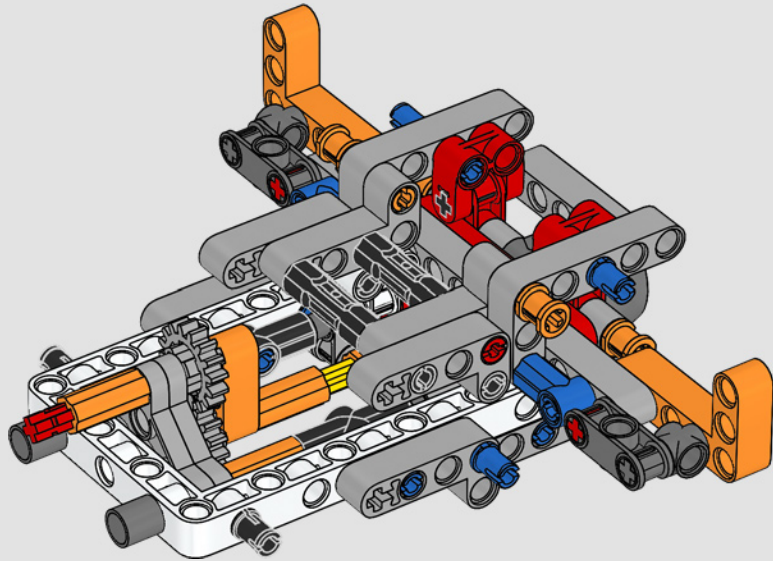

103

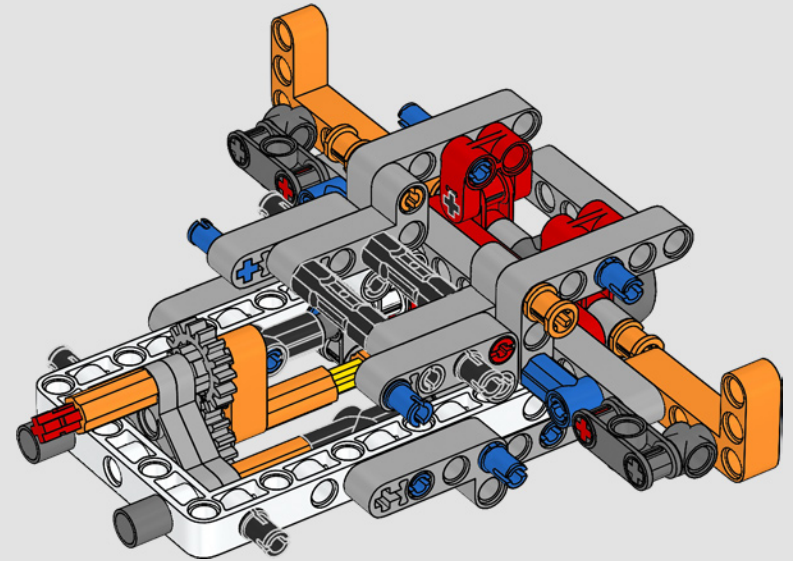

104

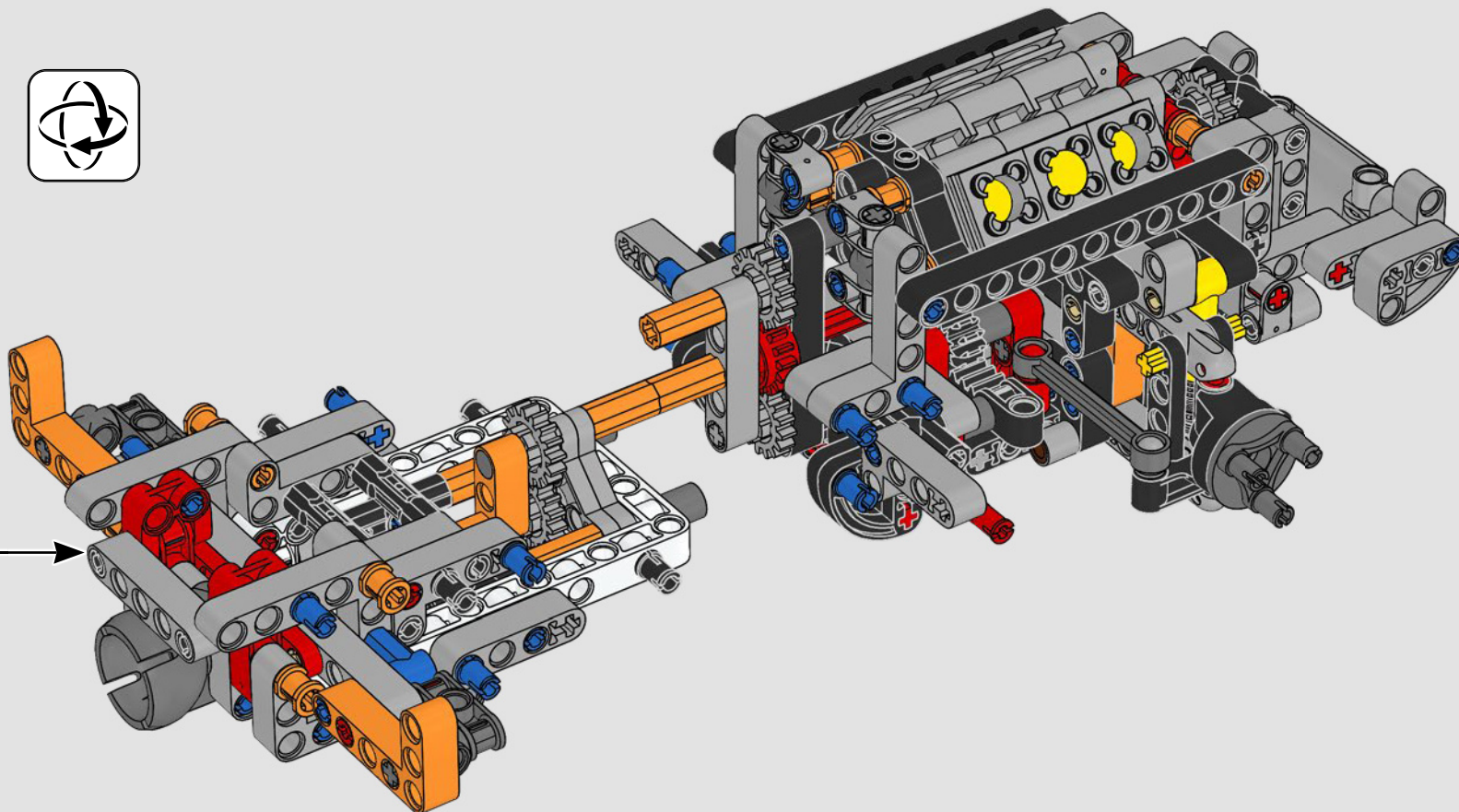

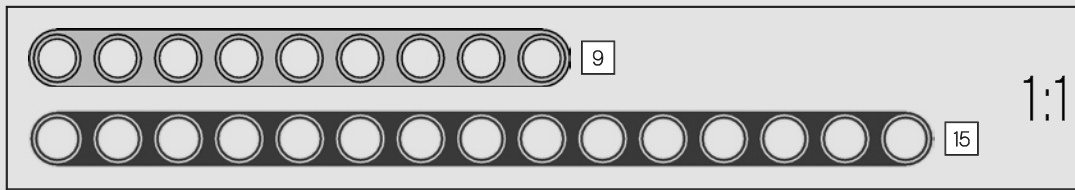
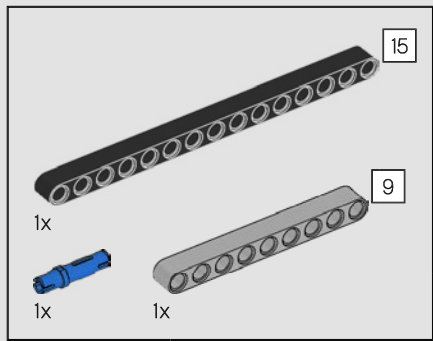

105

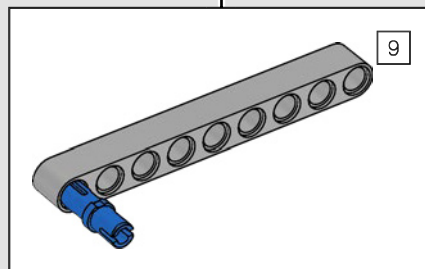
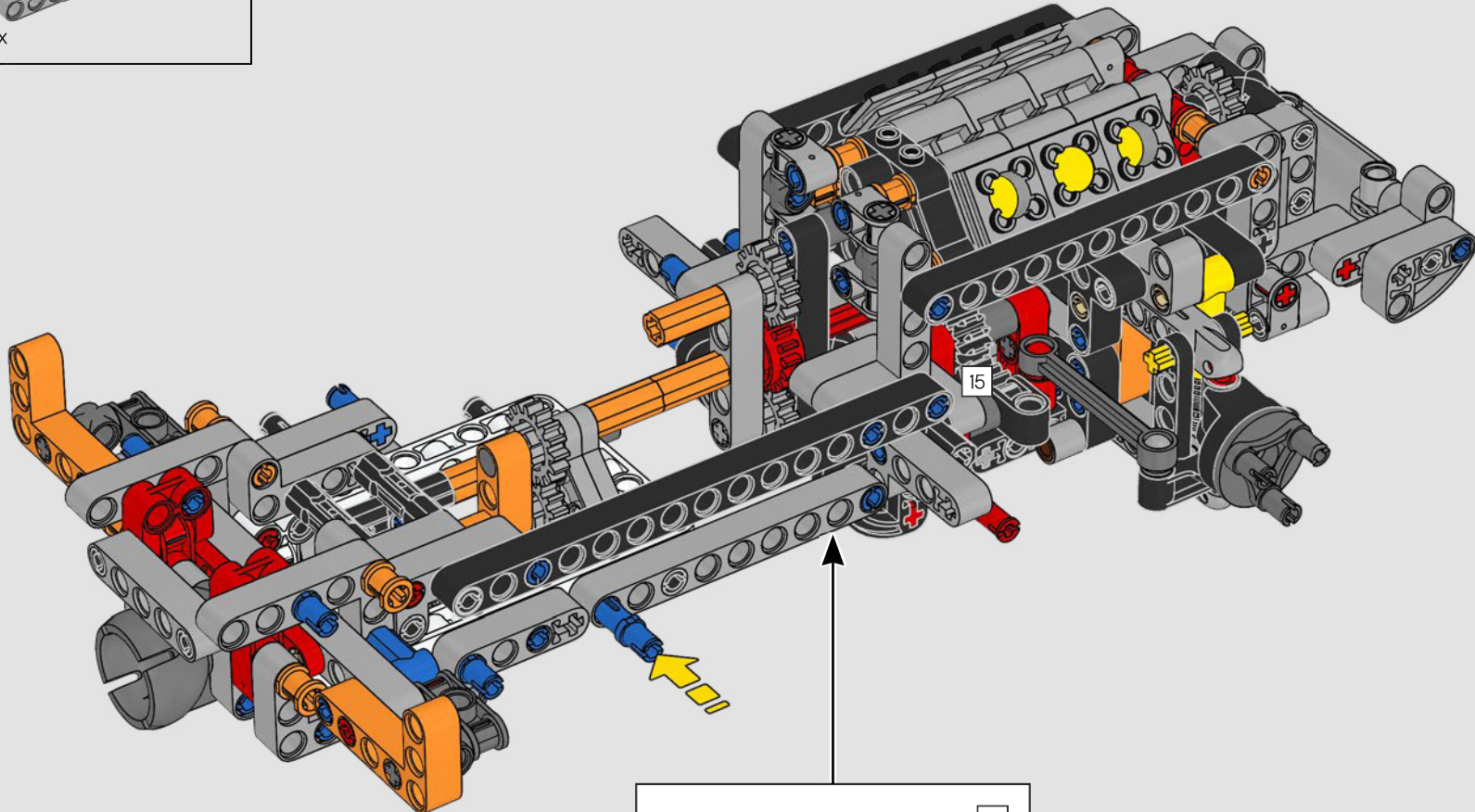

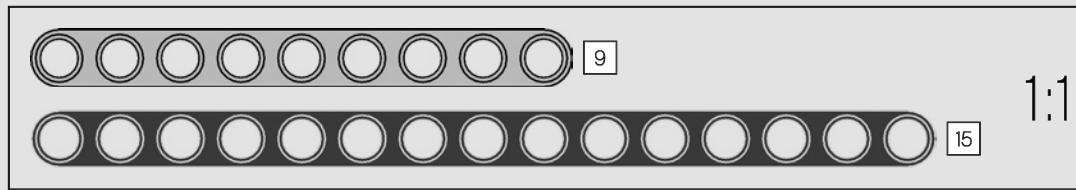
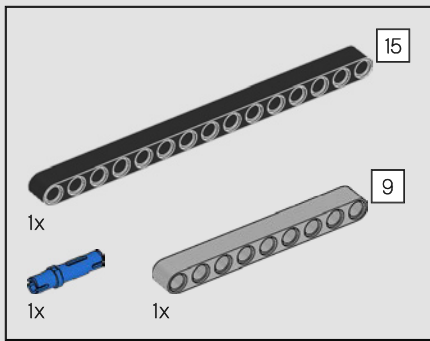

106

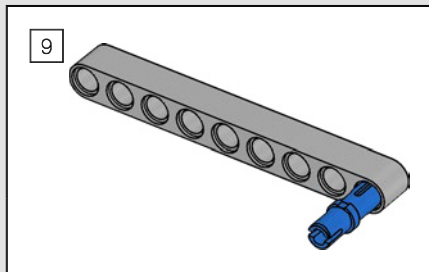
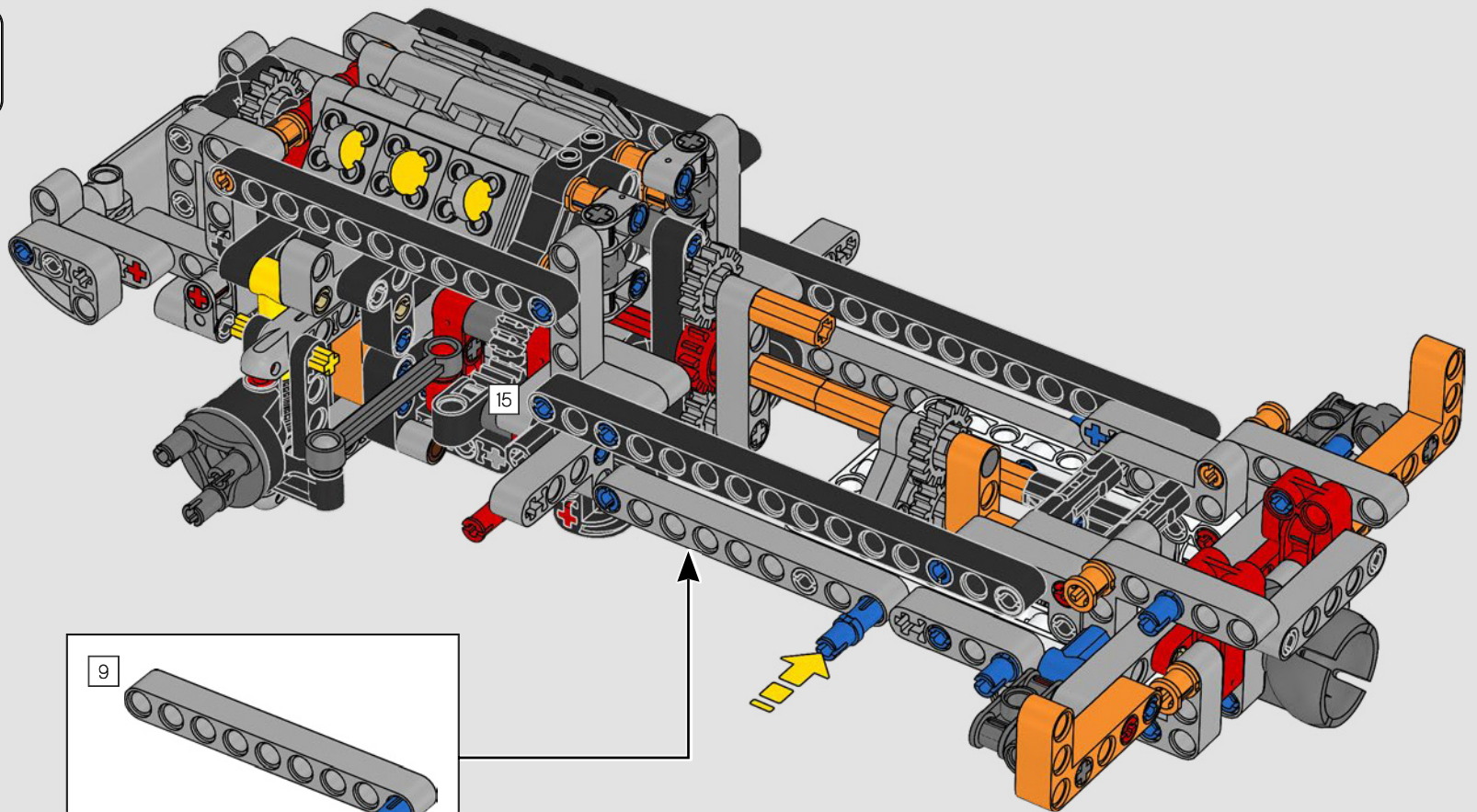

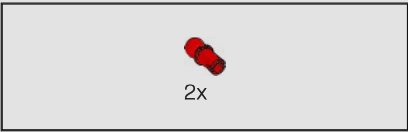
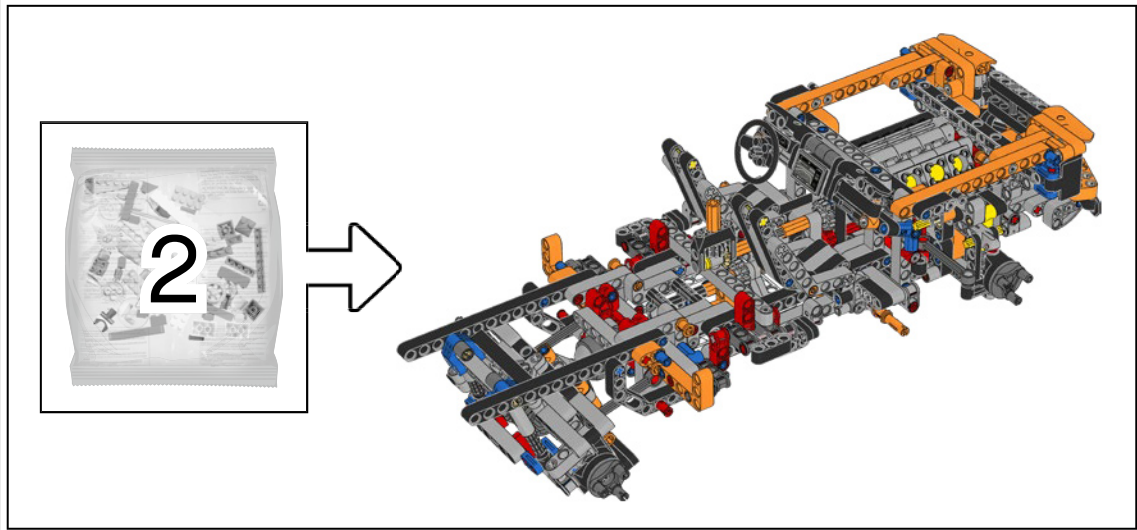

107

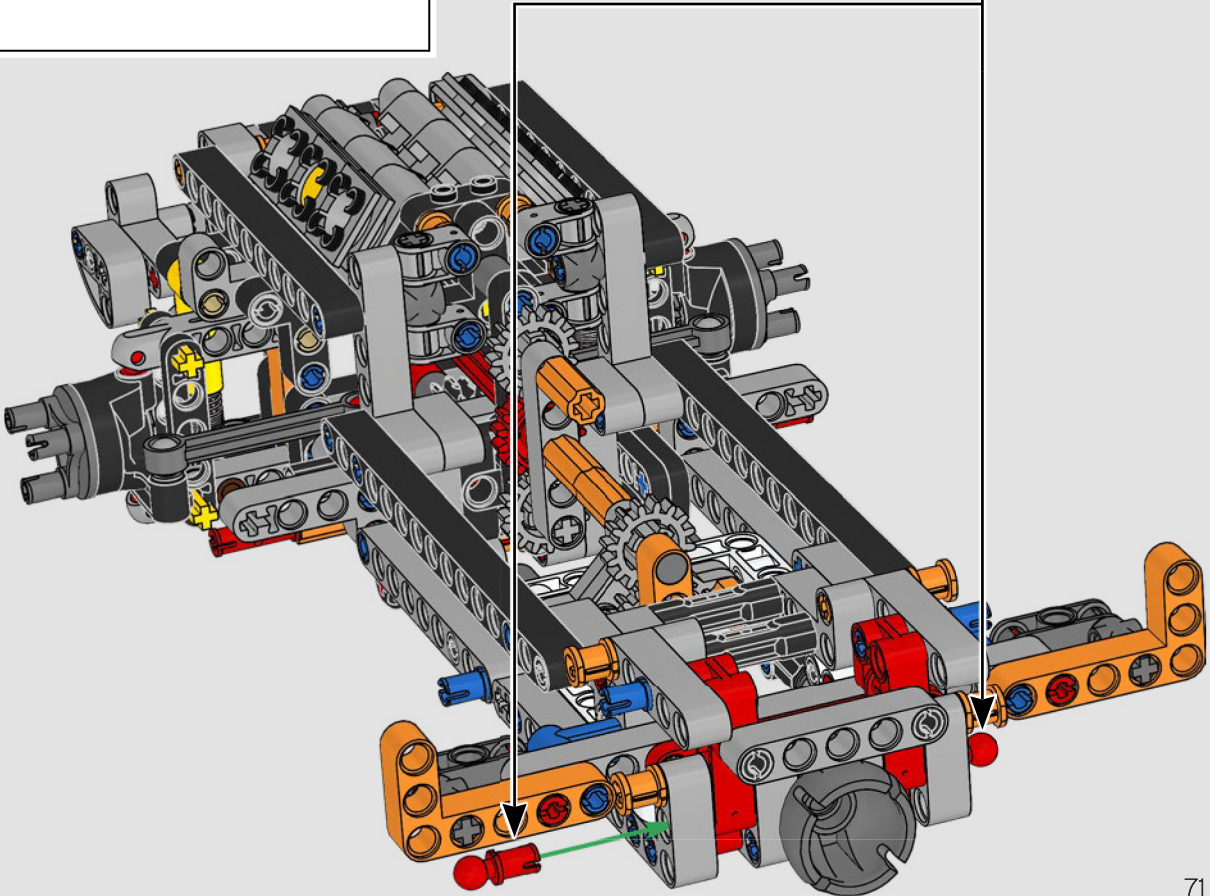

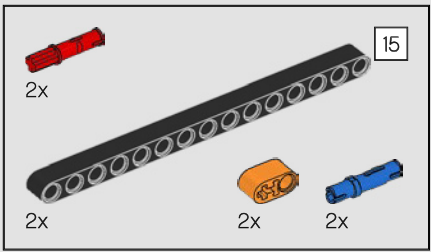

108

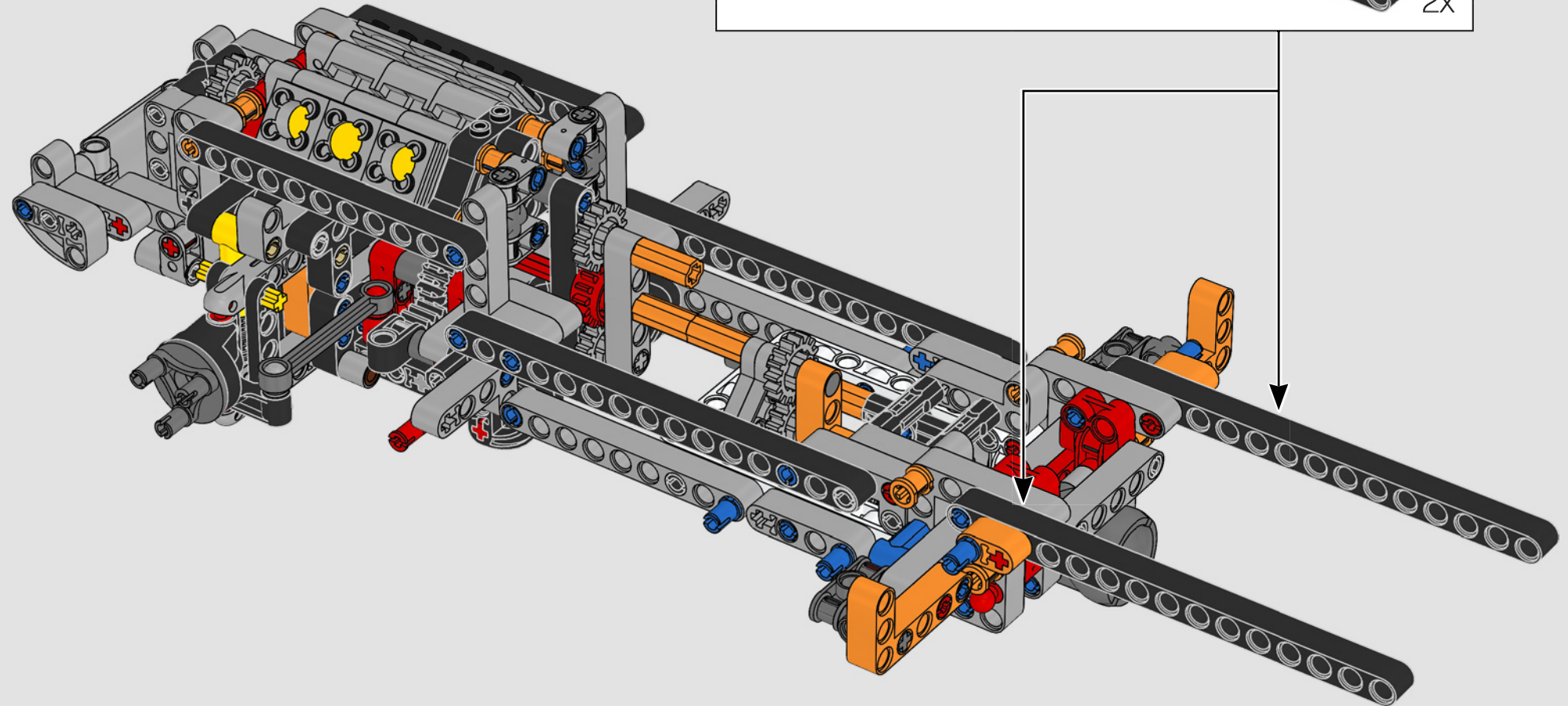
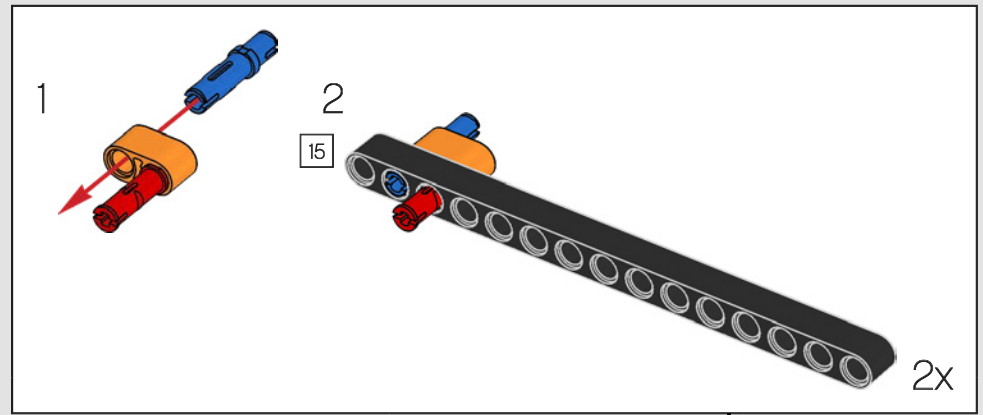

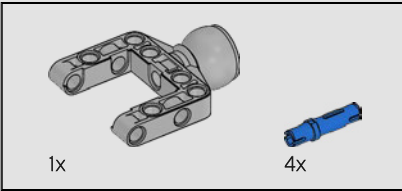
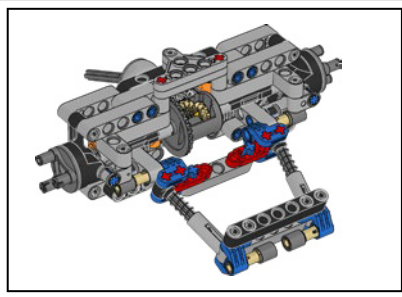

109

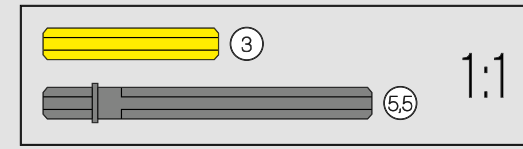
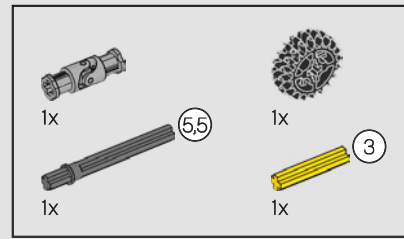
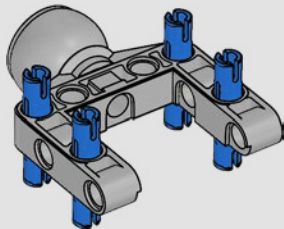

110

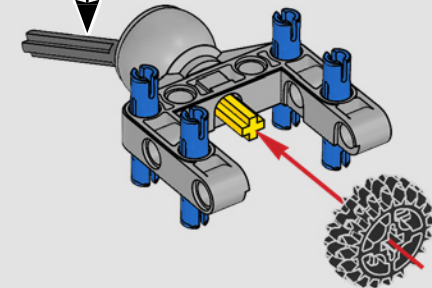
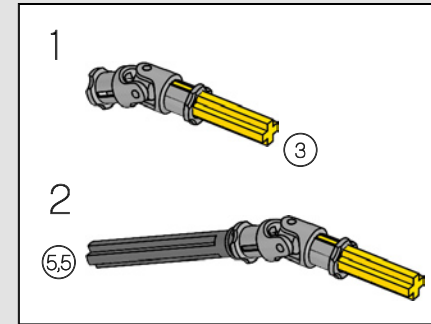

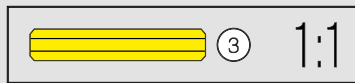
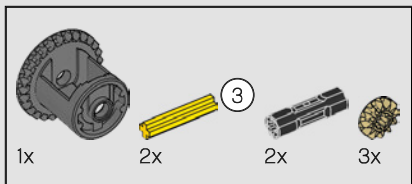

111

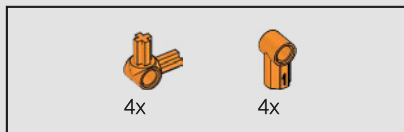
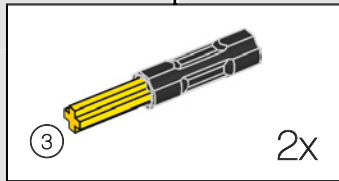
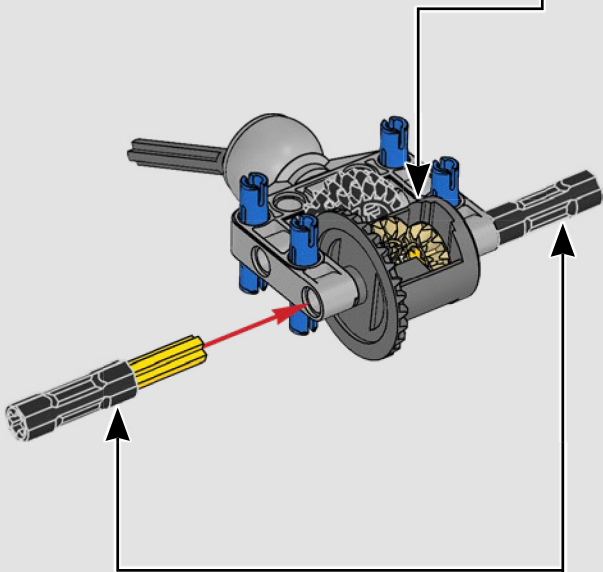
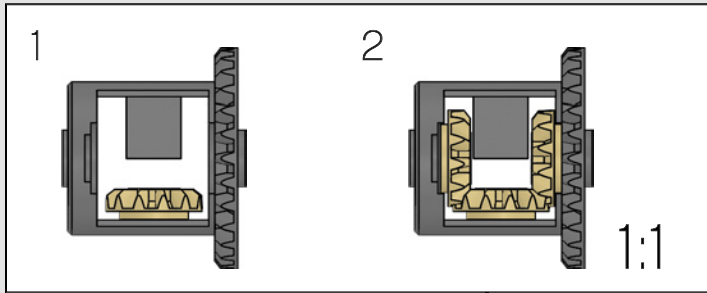

112

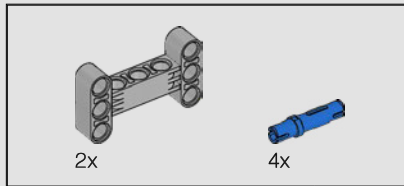
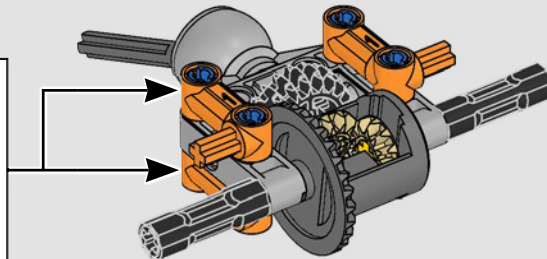
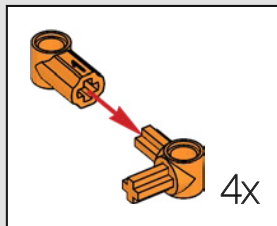

113

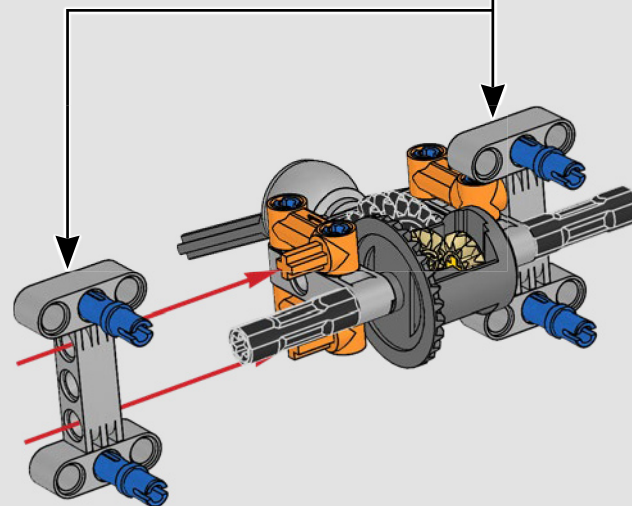
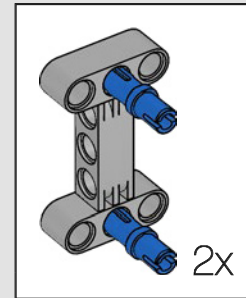

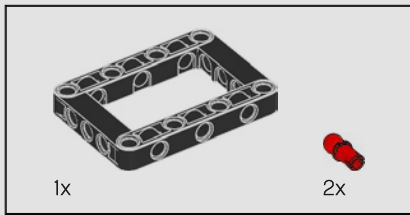

114

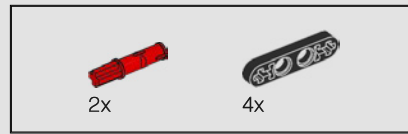
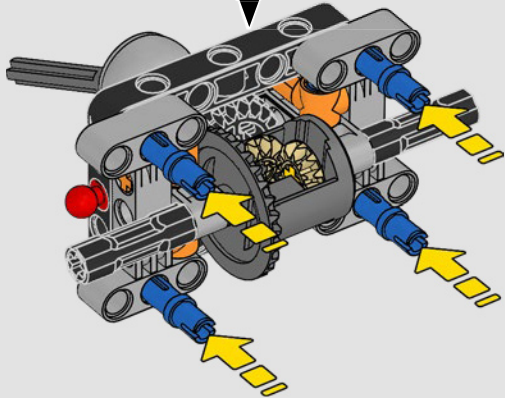
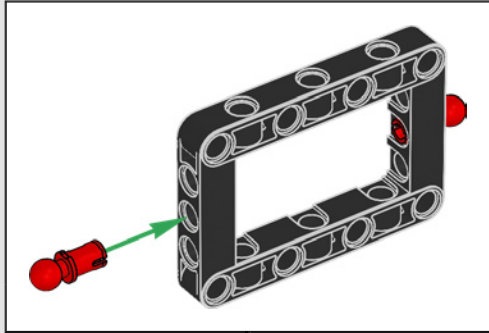

115

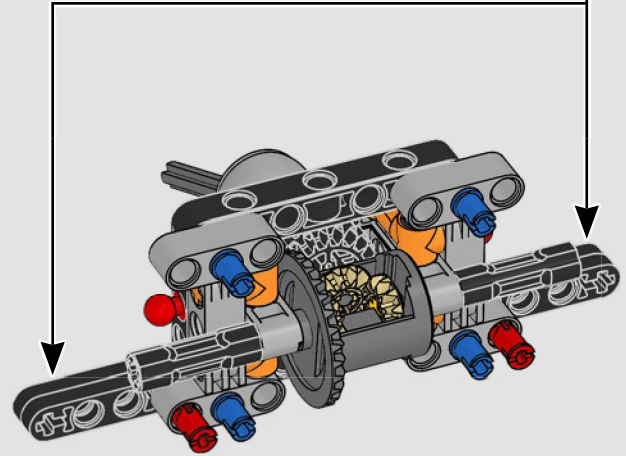
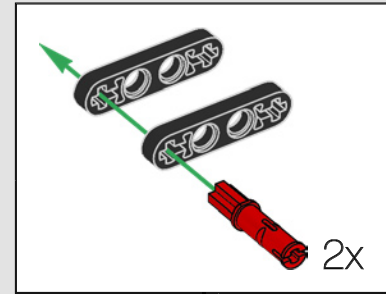

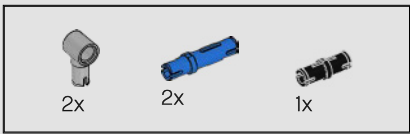

116

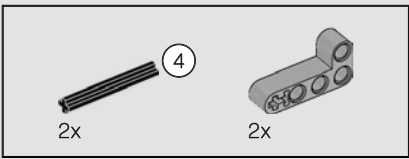
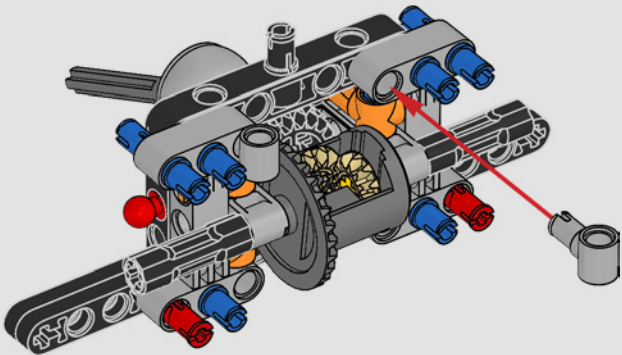

117

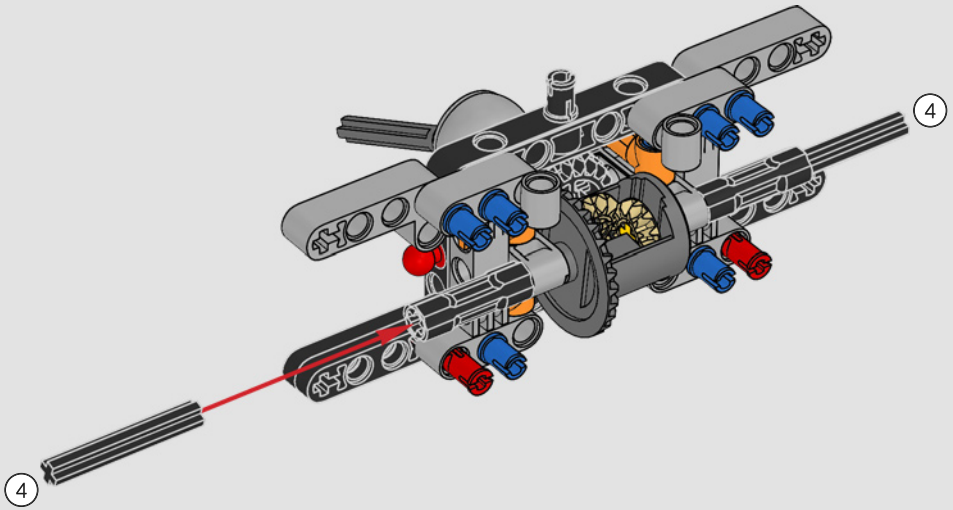
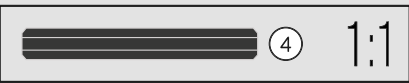

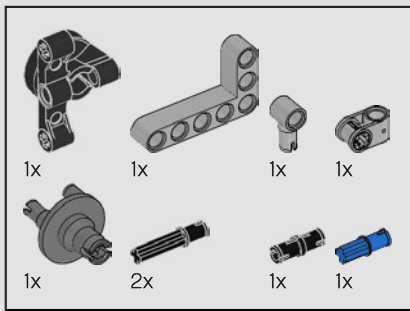

118

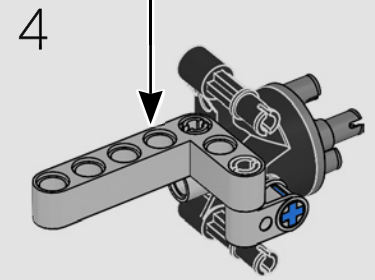
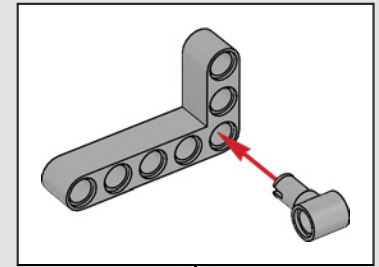
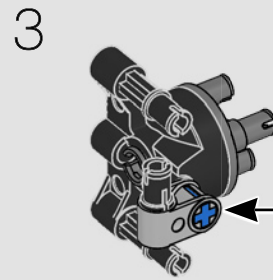
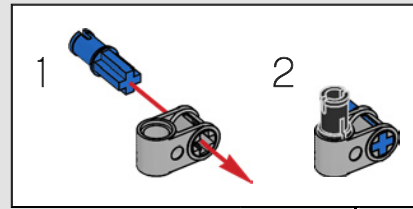
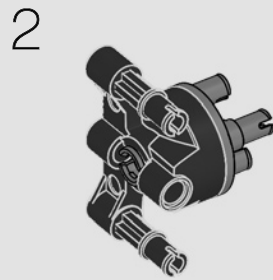
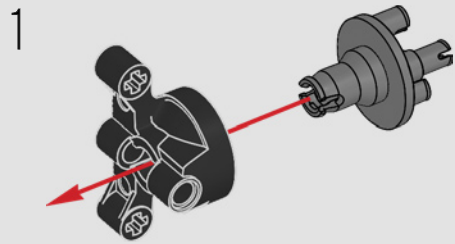

119

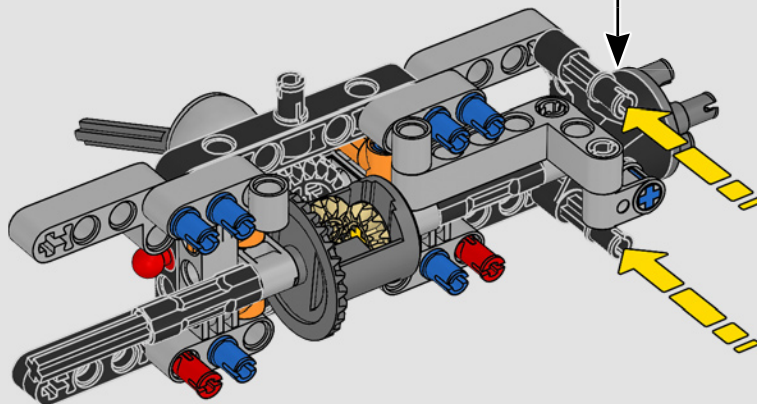

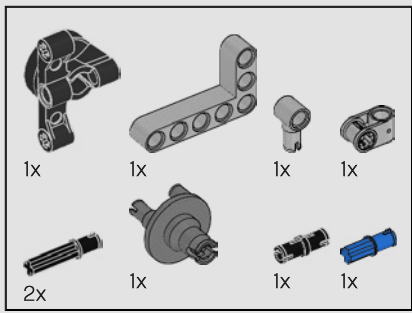

120

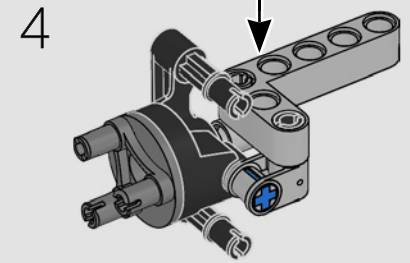
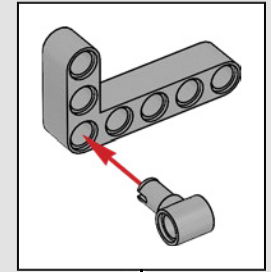
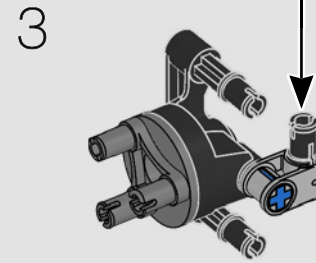
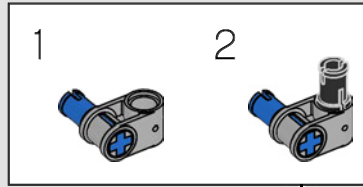
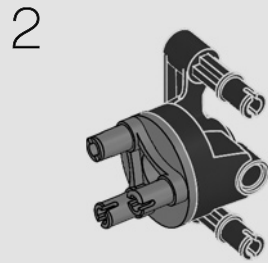
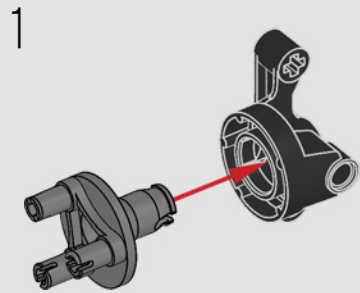

121

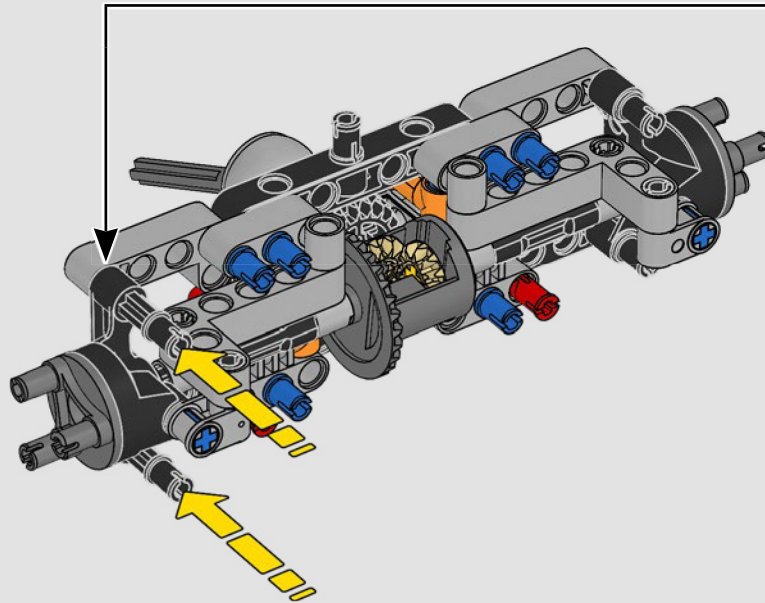

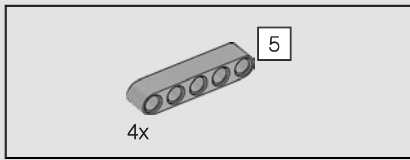

122

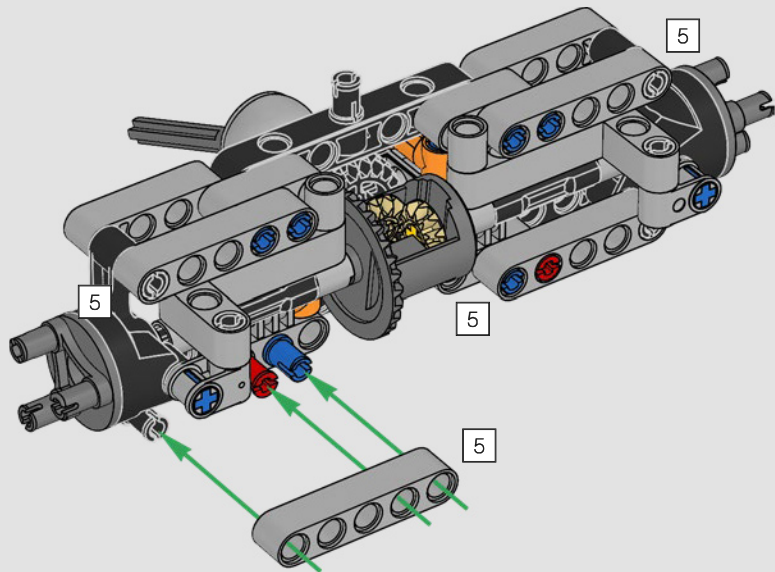

123

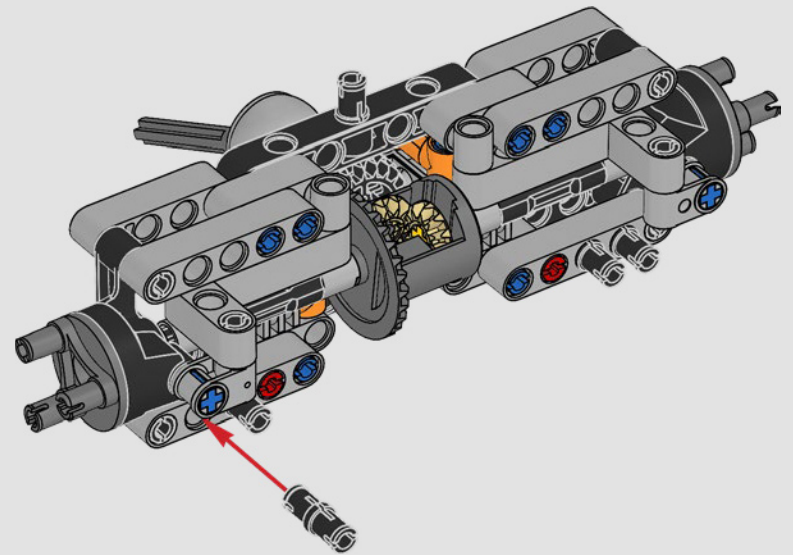

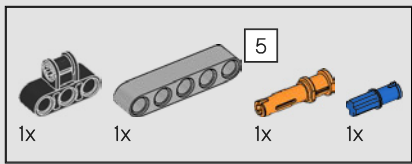

124

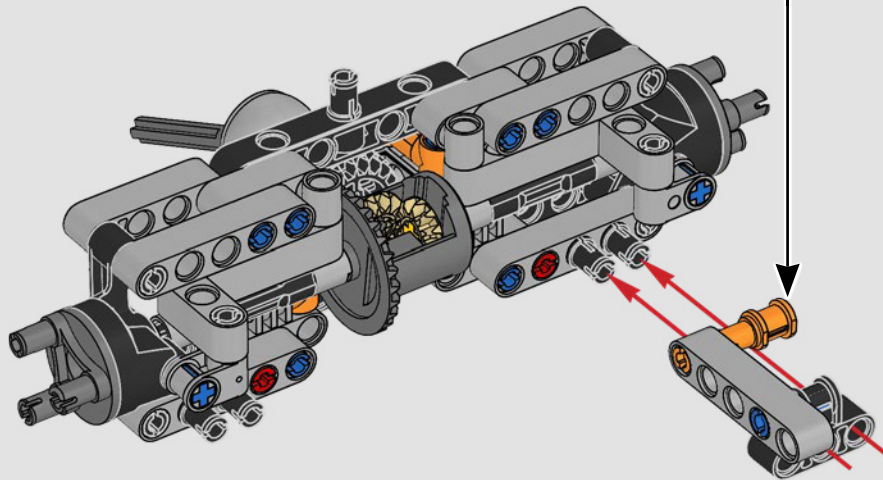
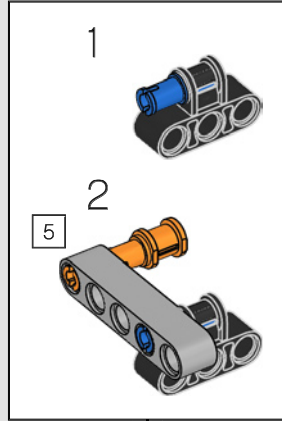

125

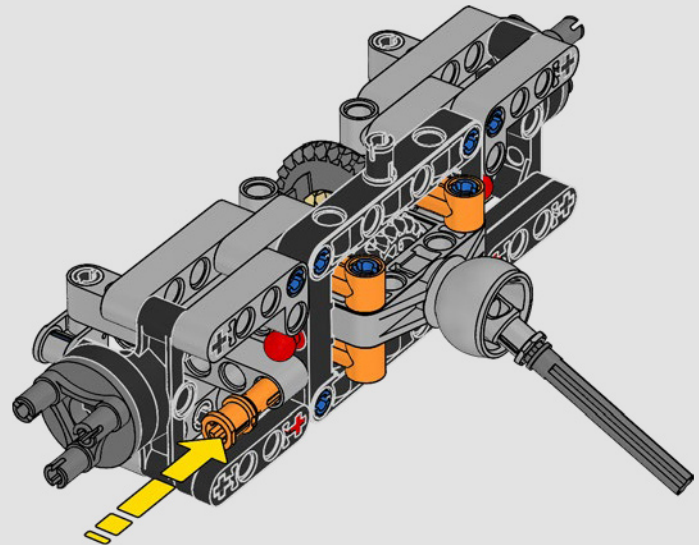
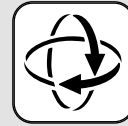

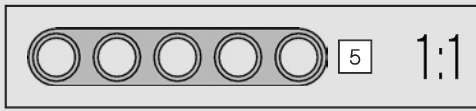
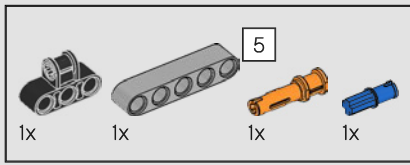

126

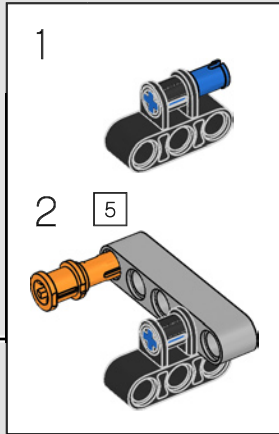
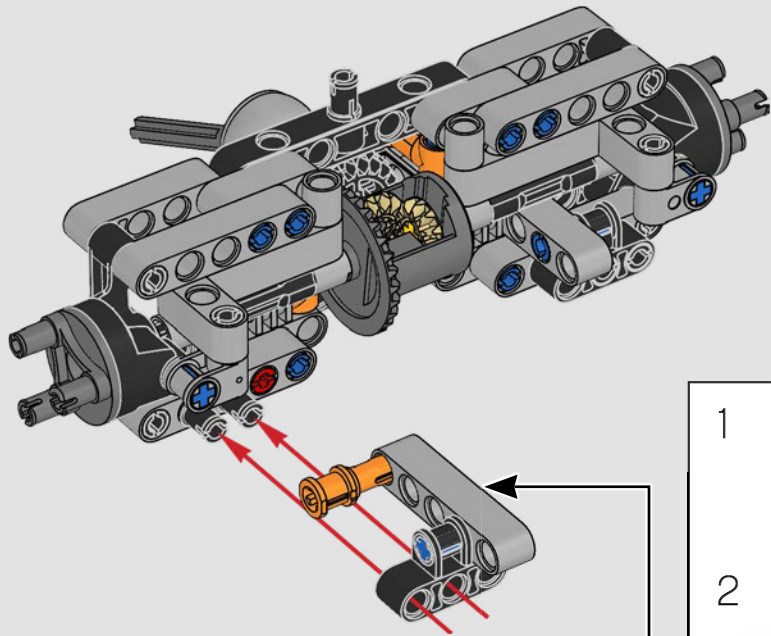

127

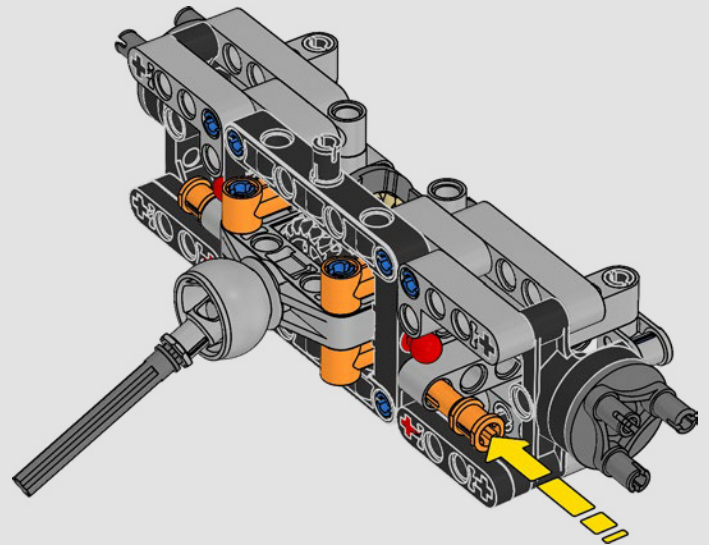
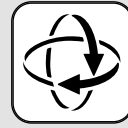

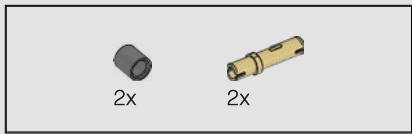

128

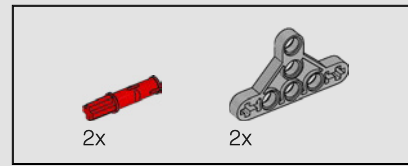
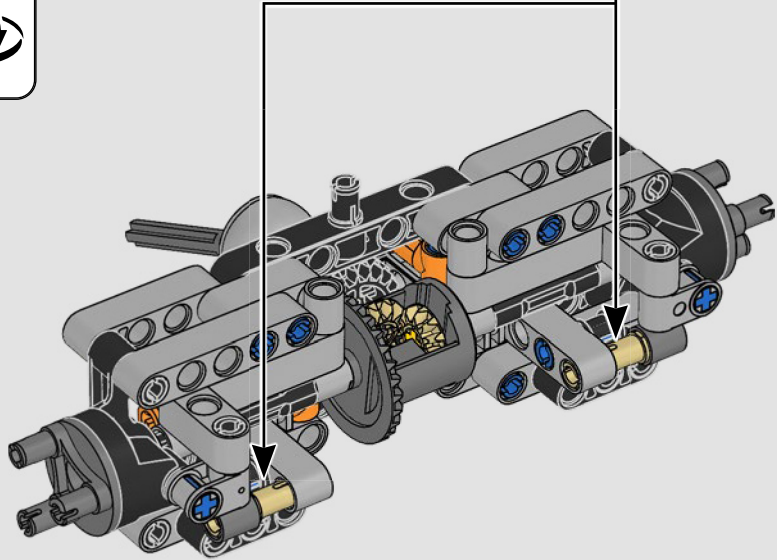
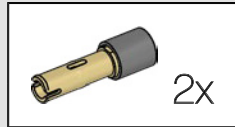

129

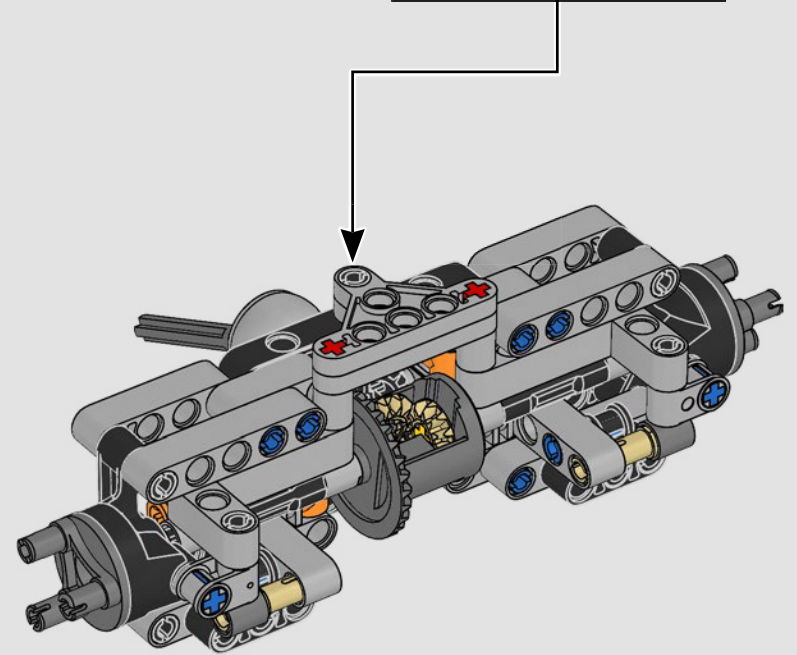
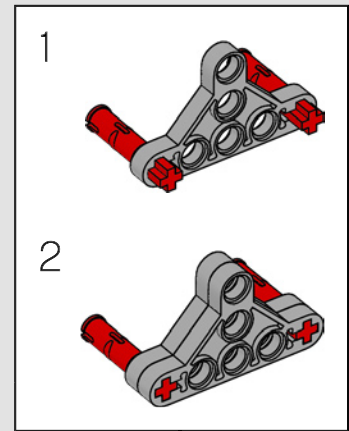

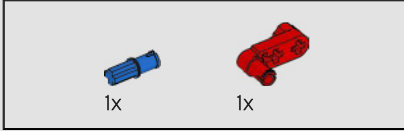
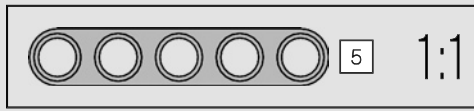
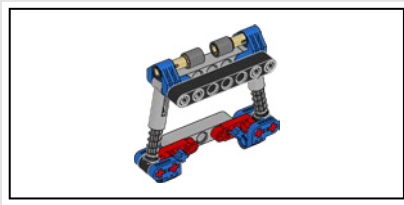

130

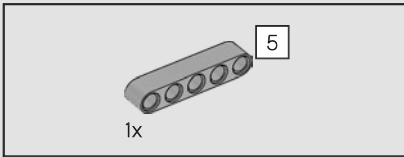
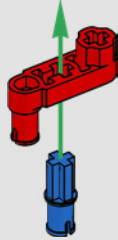

131

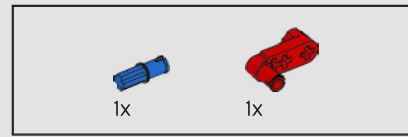
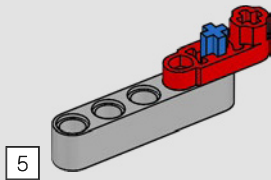

132

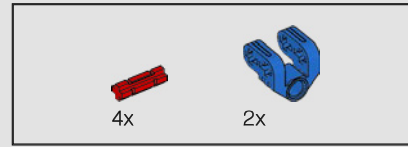
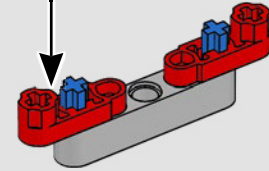
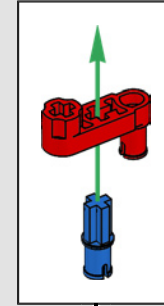

133

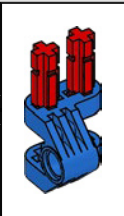
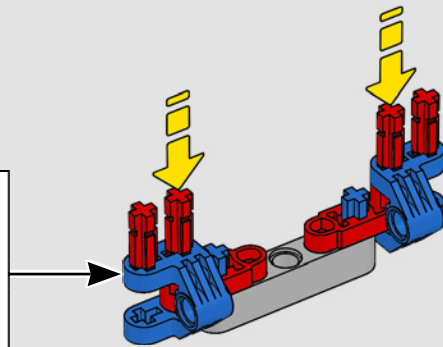
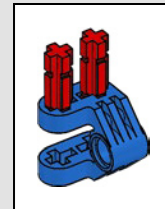

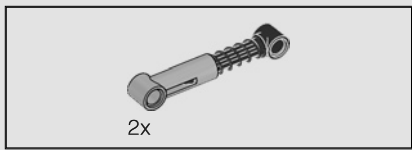

134

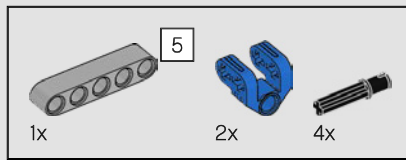
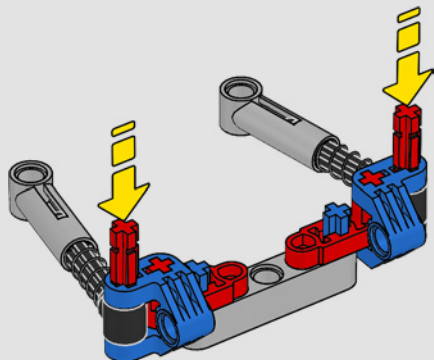

135

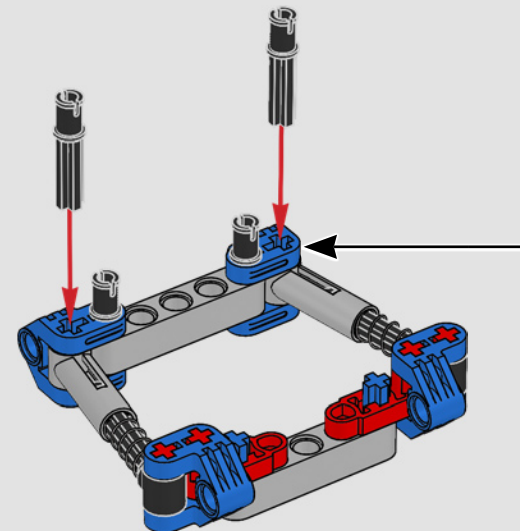
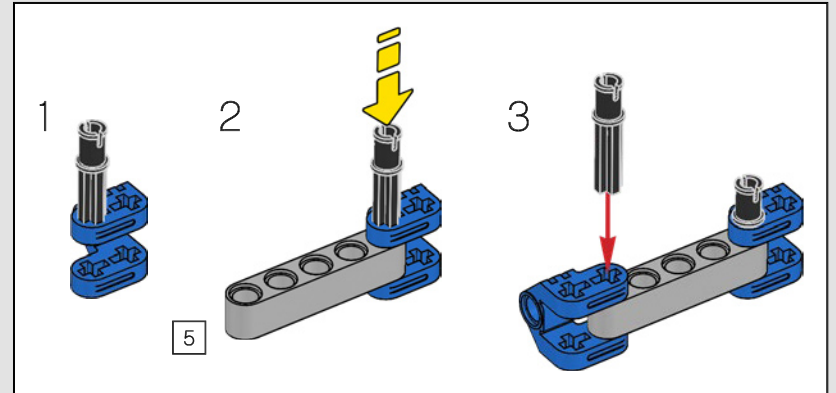
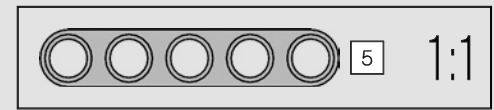

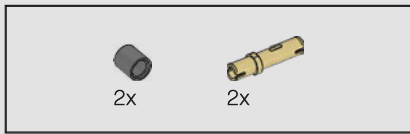

136

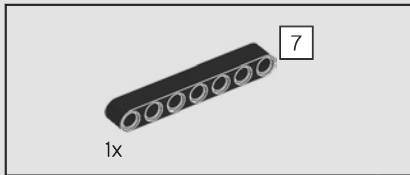
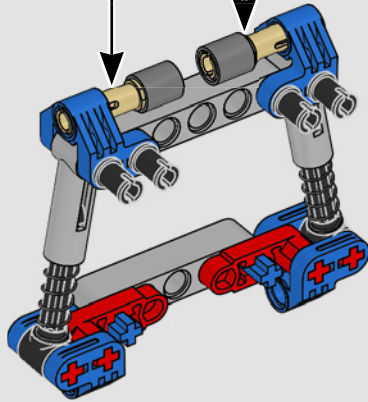
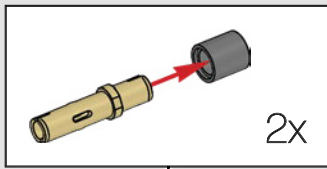

137

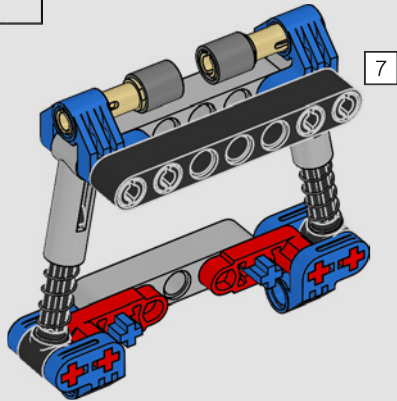

138

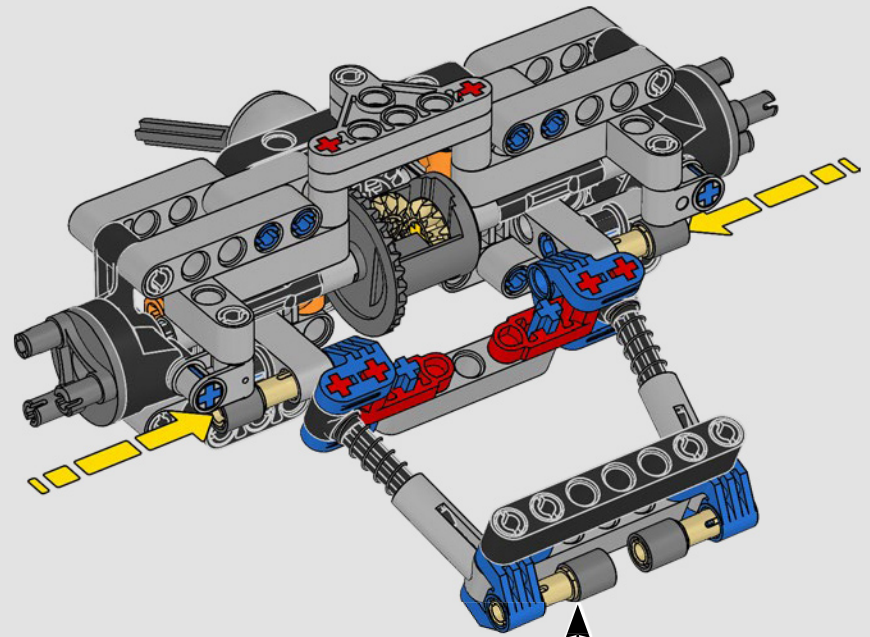

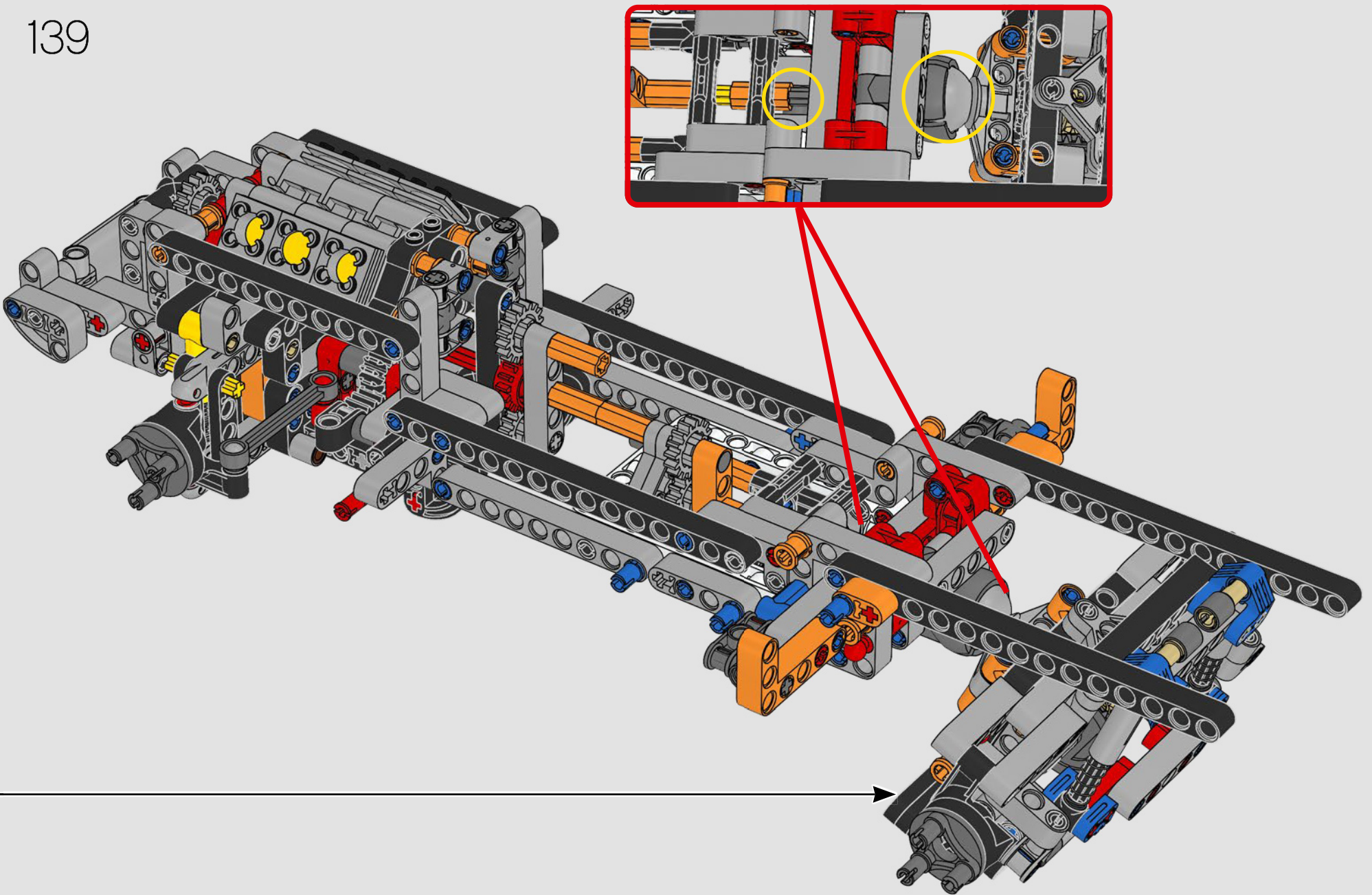

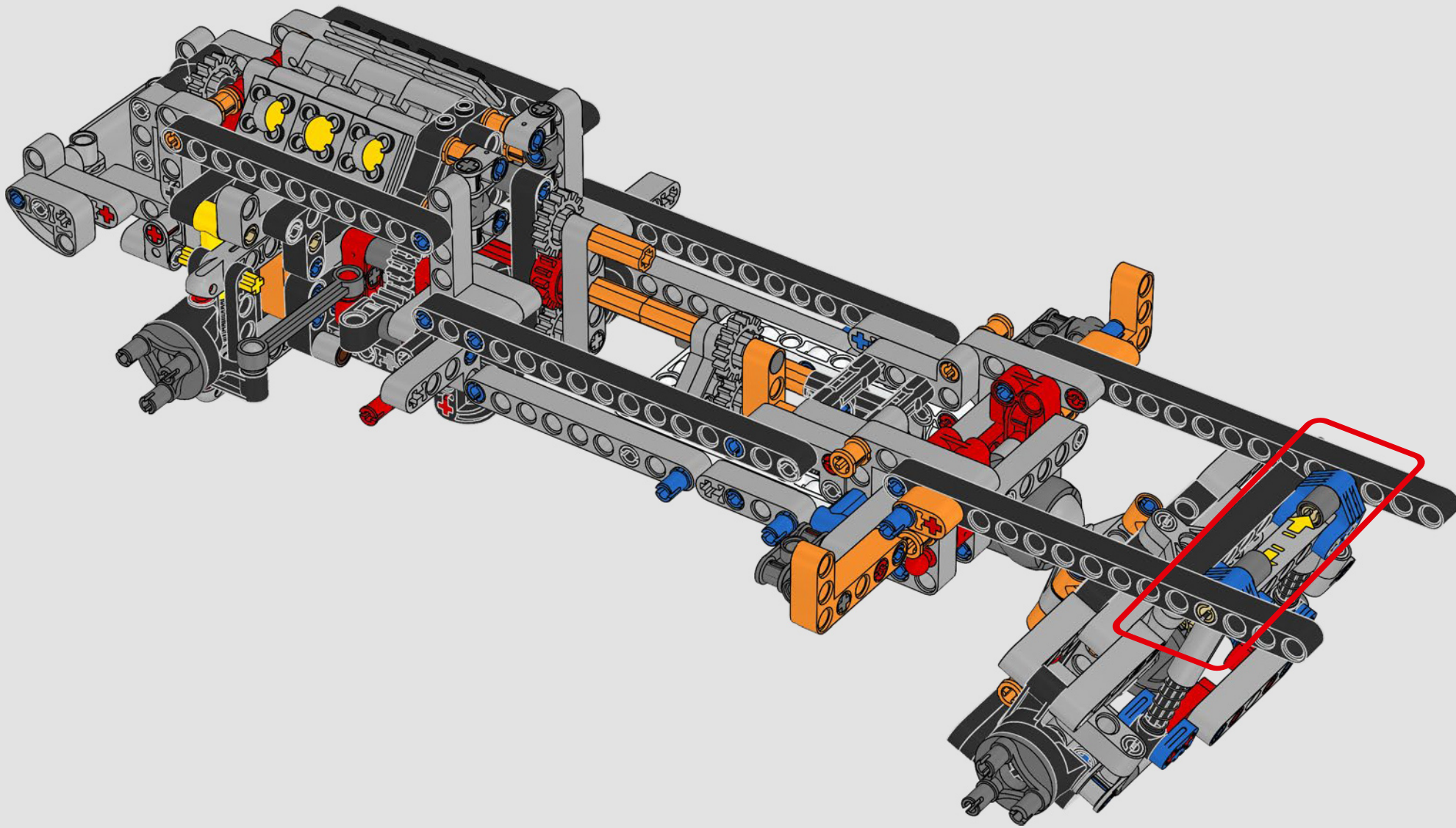

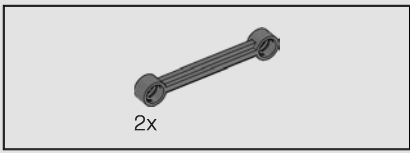

141

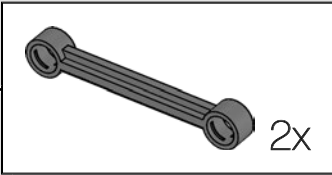
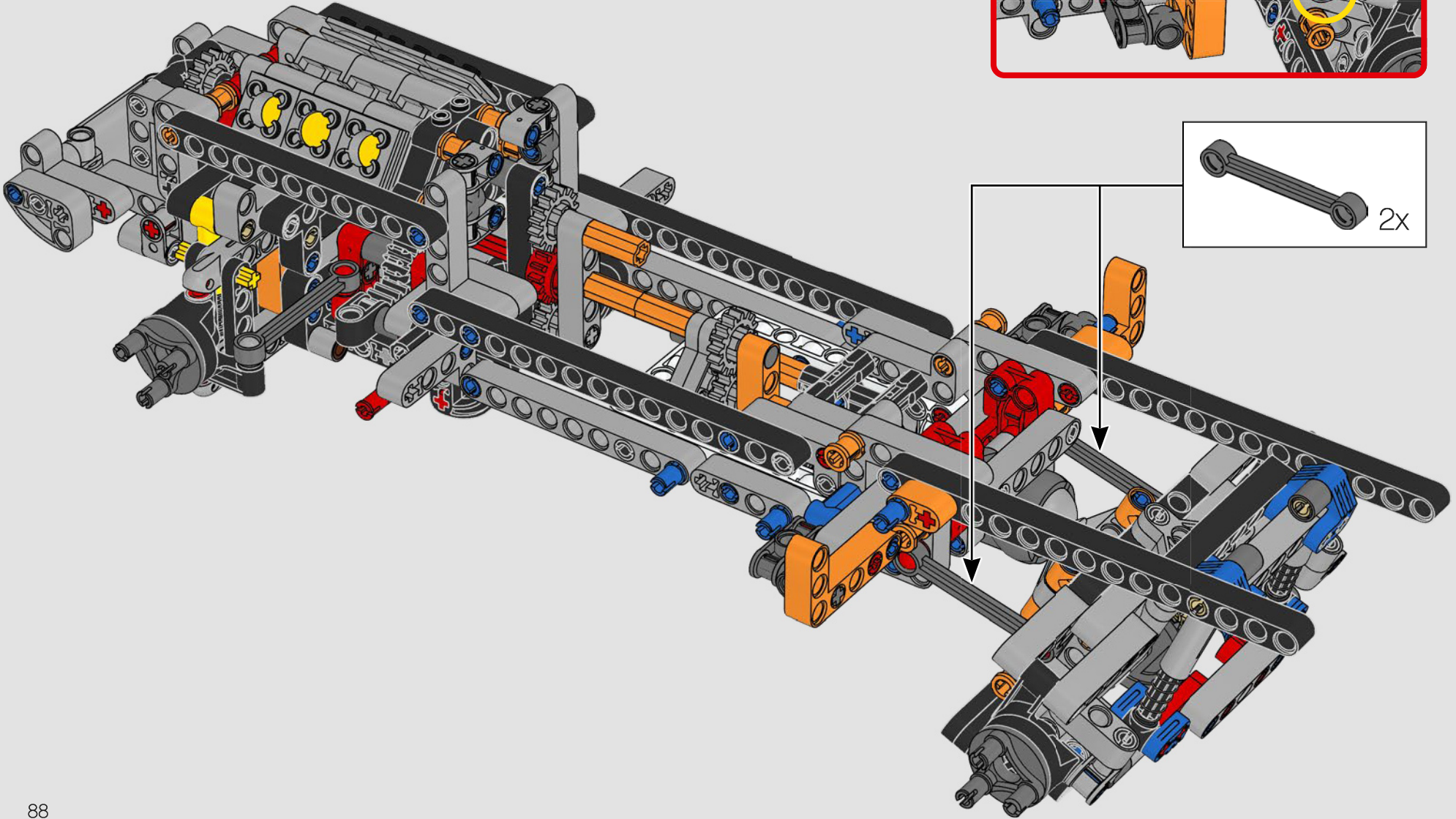
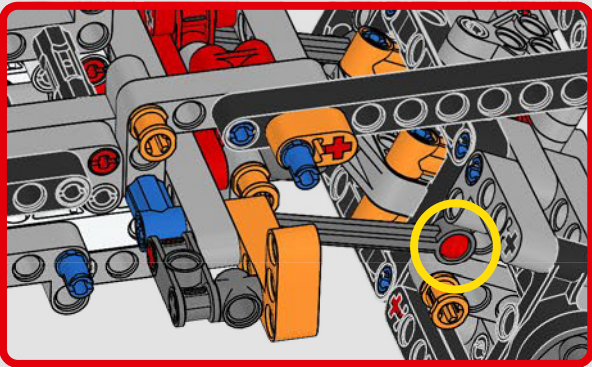

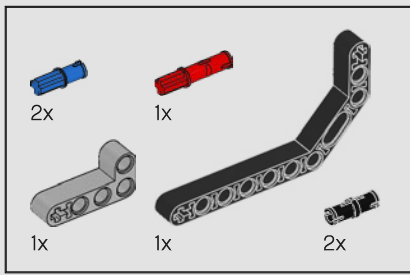

142

1

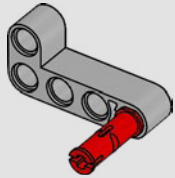

2

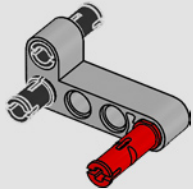

3

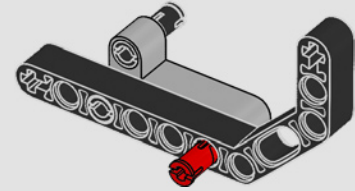

4

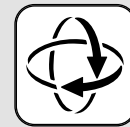
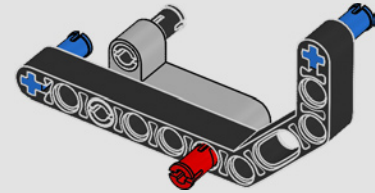

5

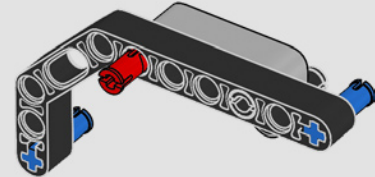

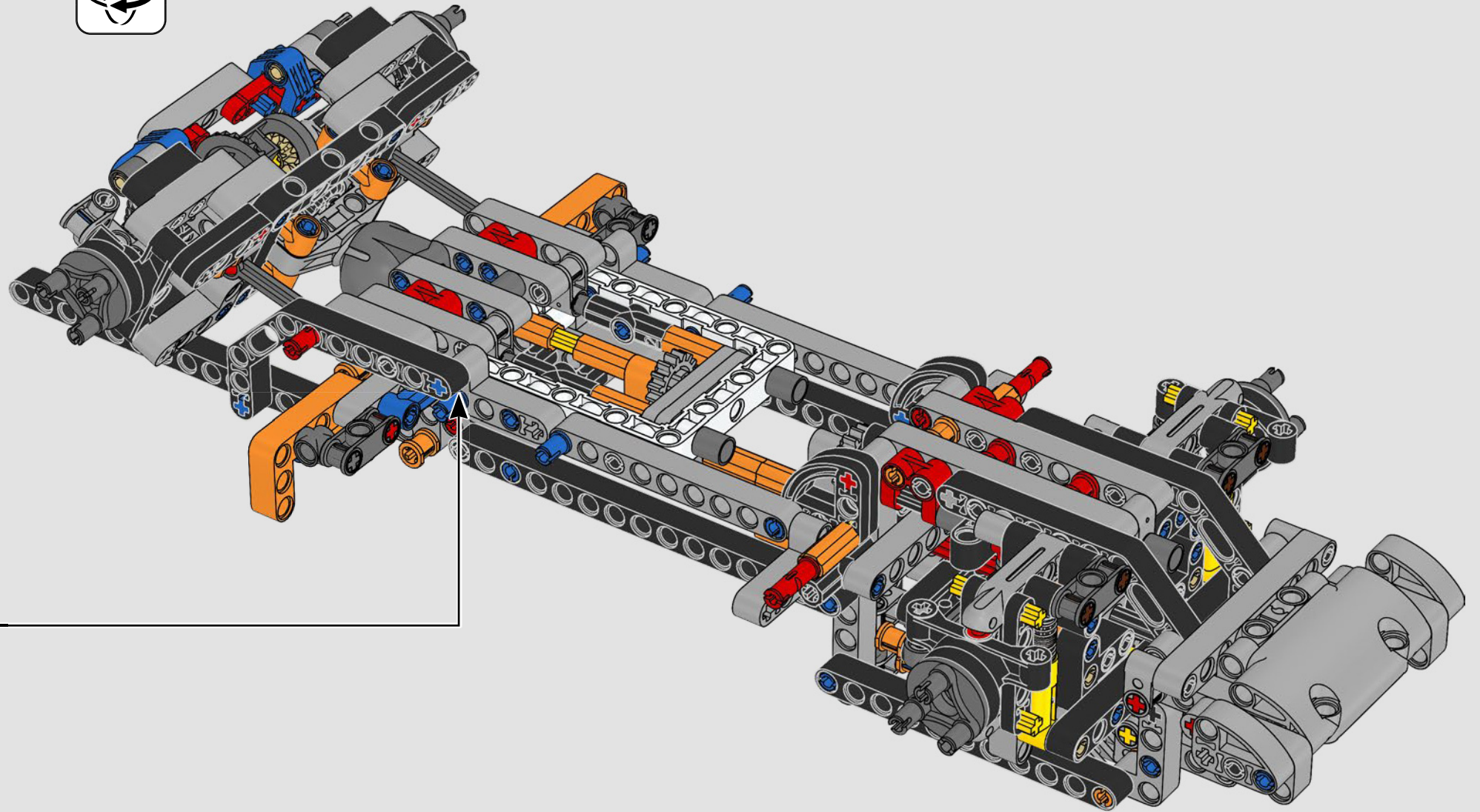

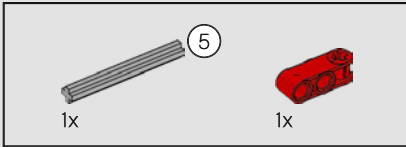
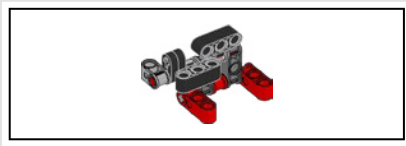

143

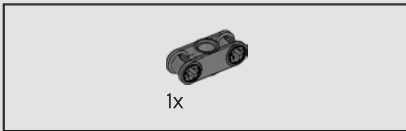
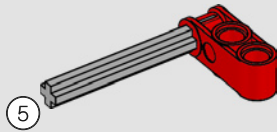

144

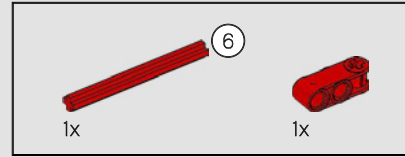
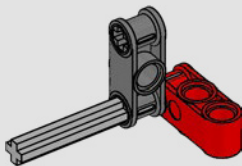

145

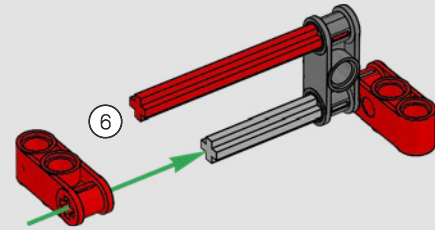

146

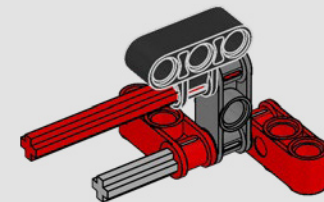

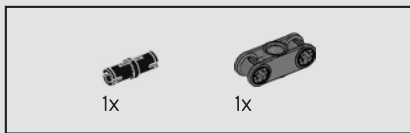

147

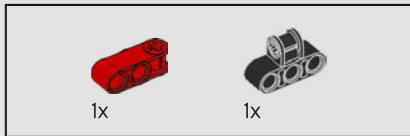
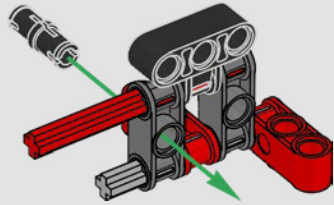

148

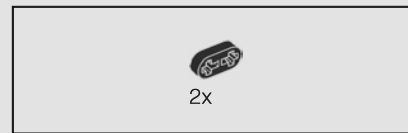
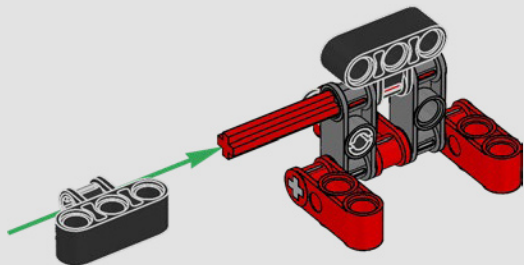

149

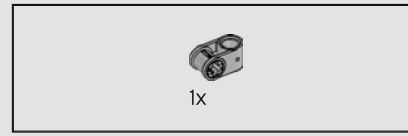
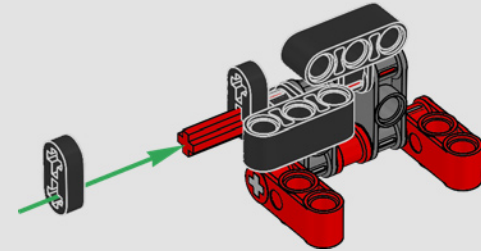

150

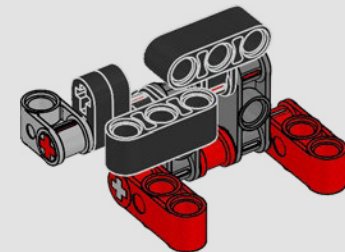

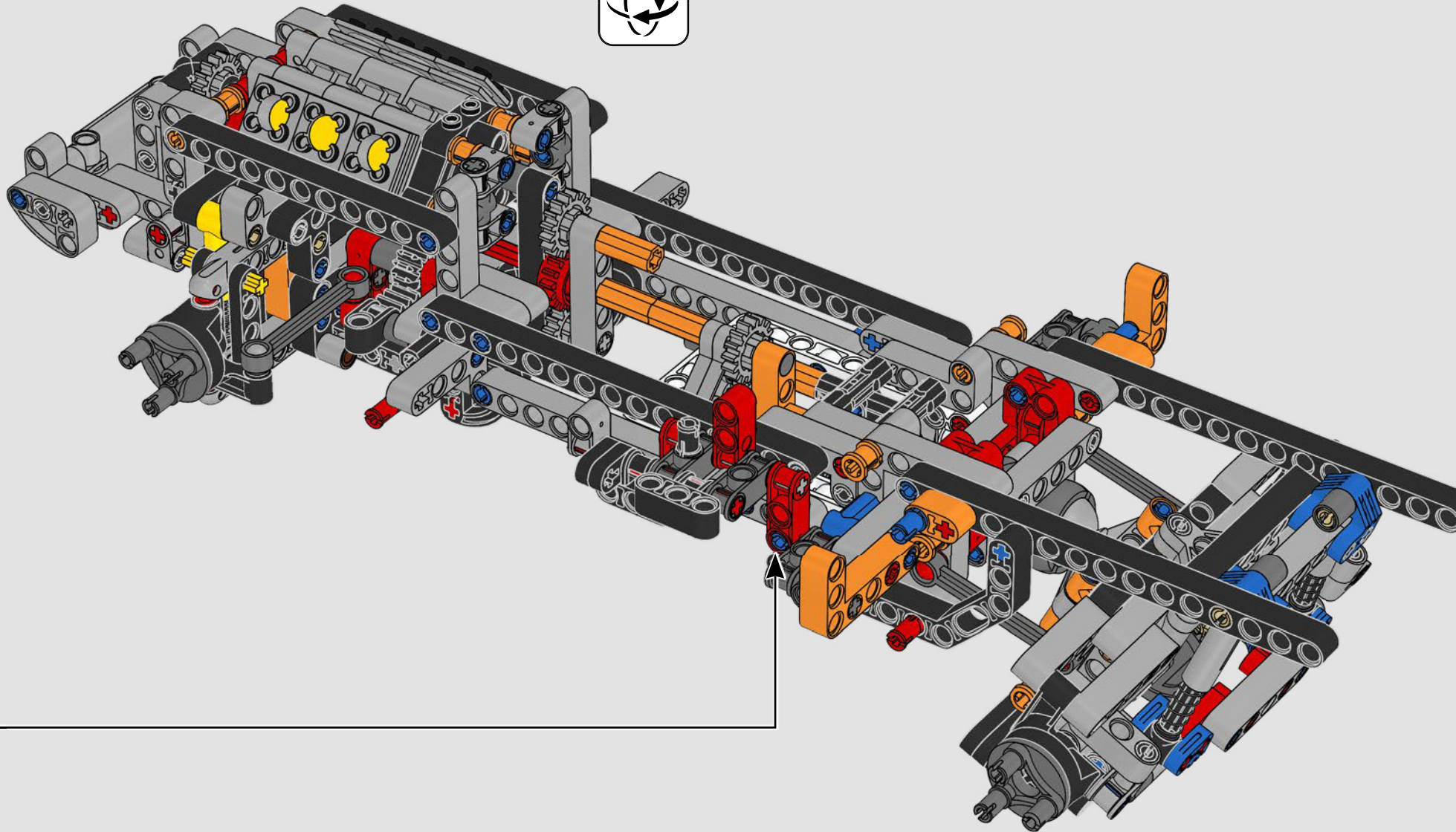

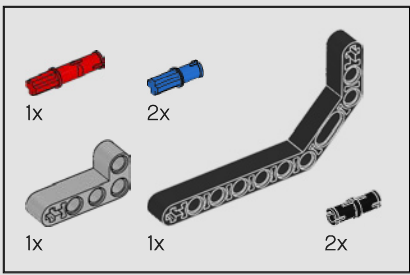

152

1

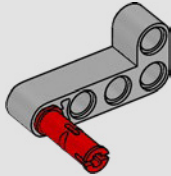

2

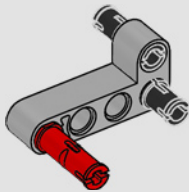

3

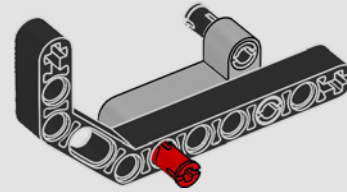

4

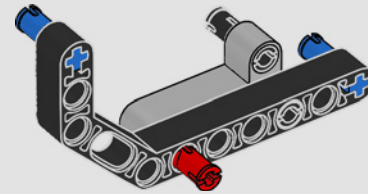

5

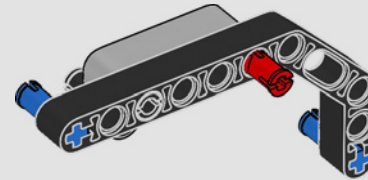
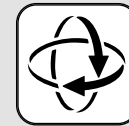

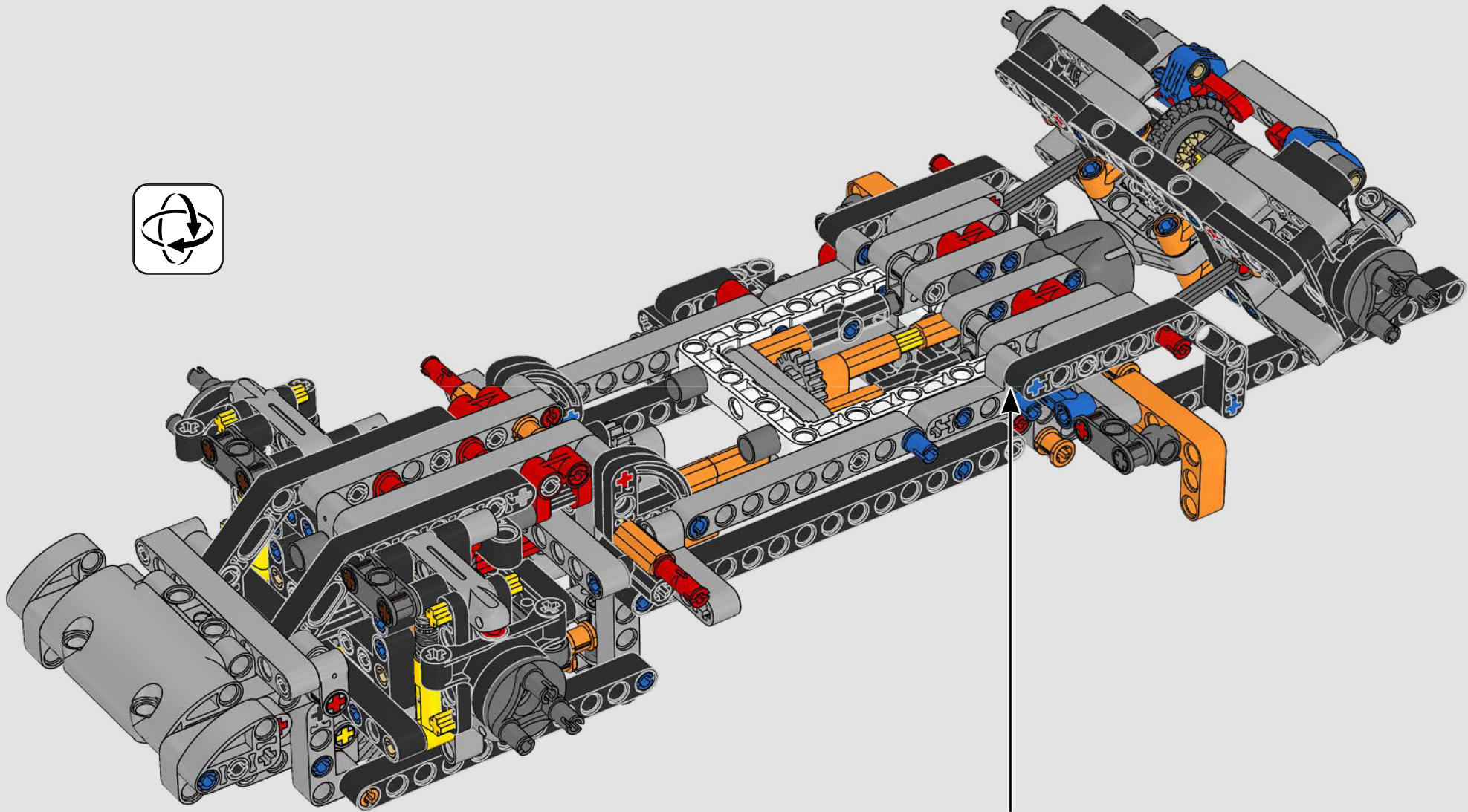

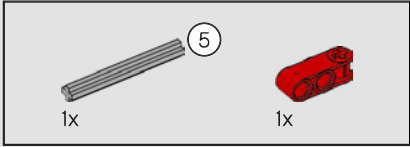

153

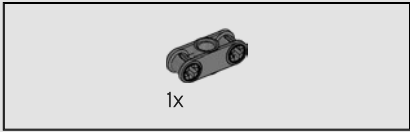
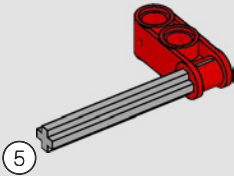

154

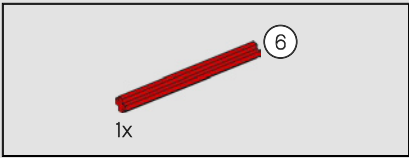
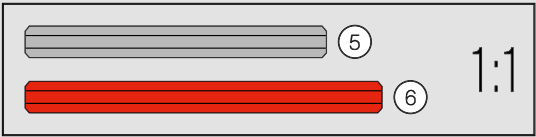
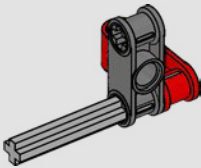

155

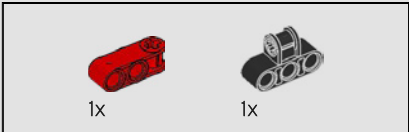
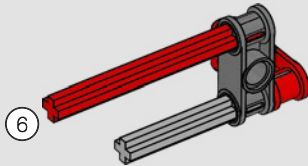

156

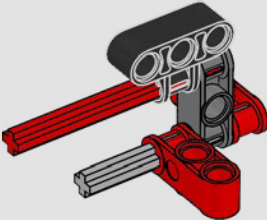

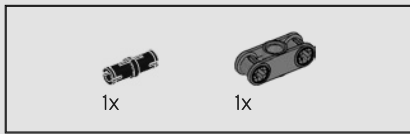

157

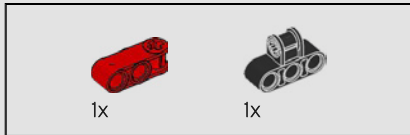
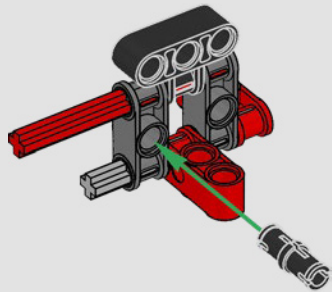

158

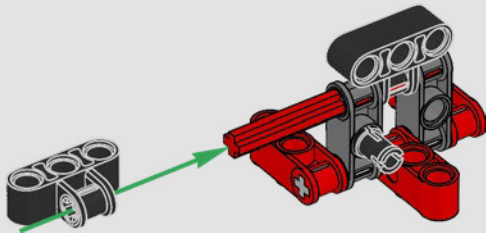

159

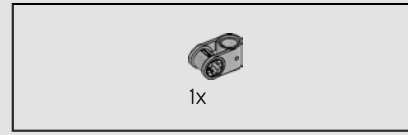
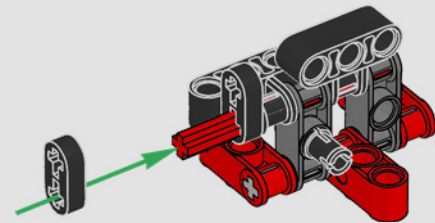

160

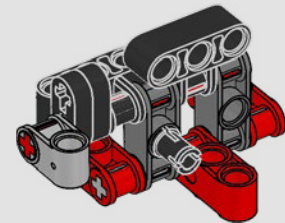

161

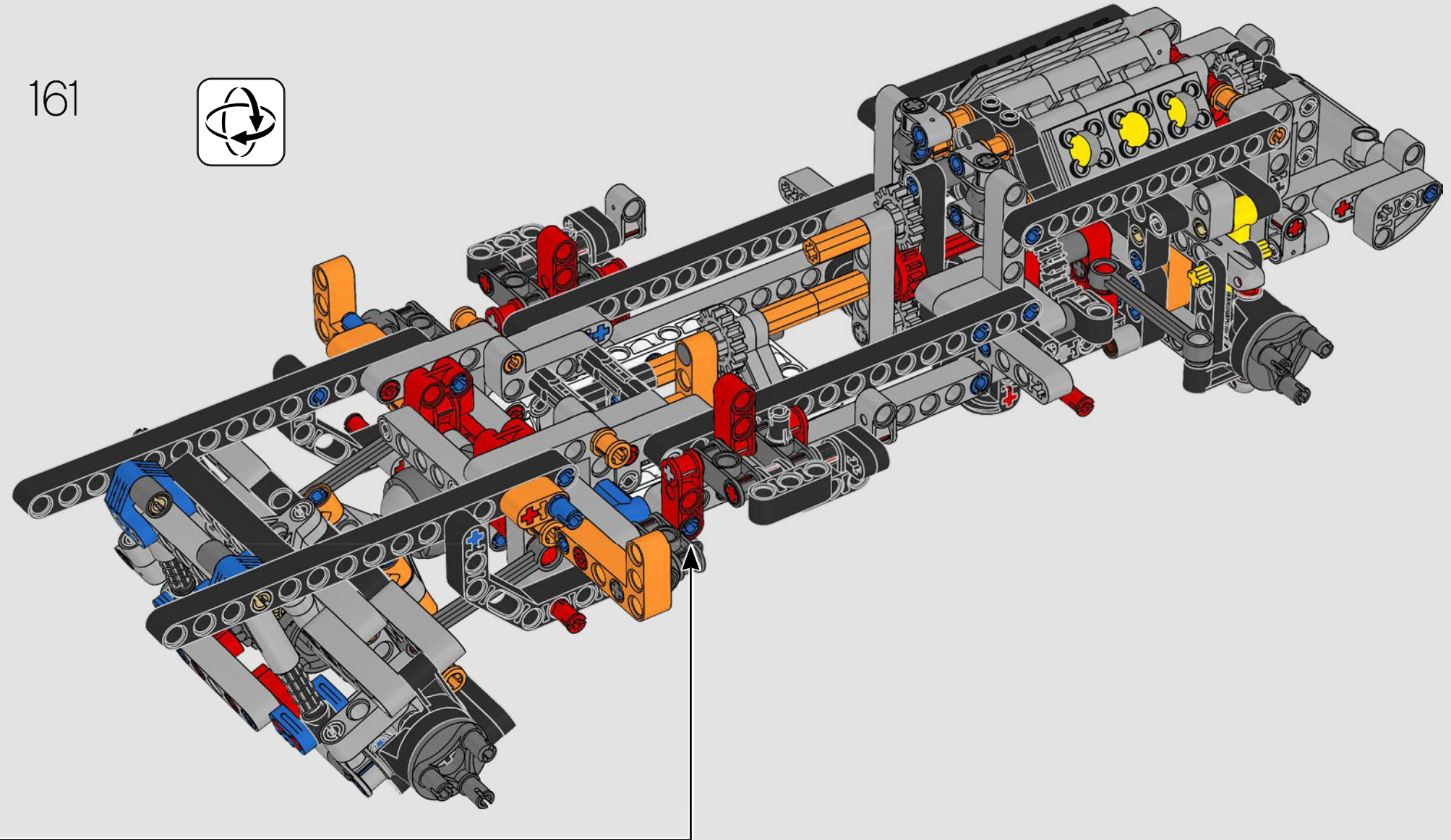

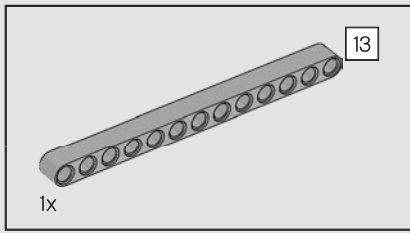

162

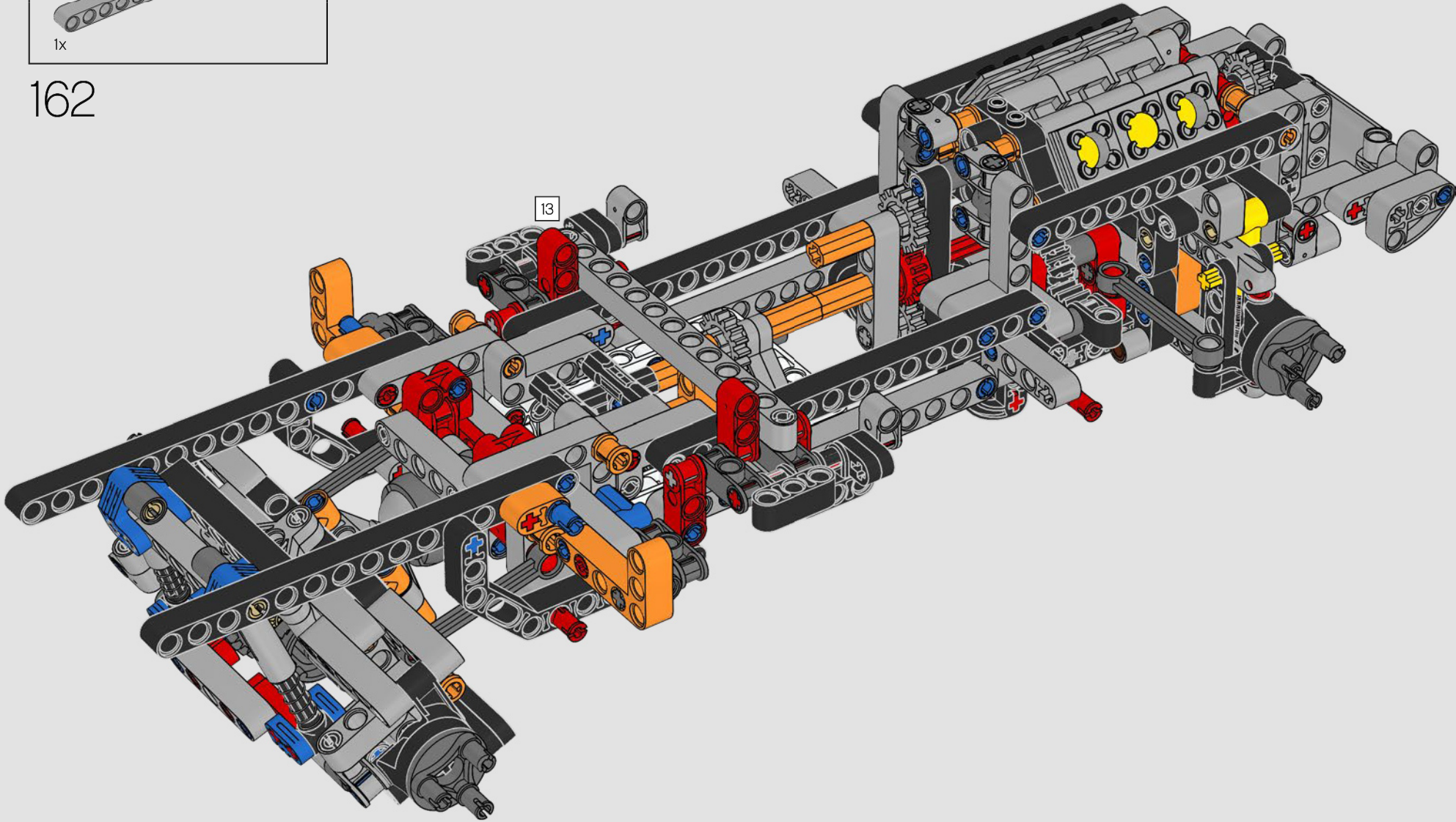

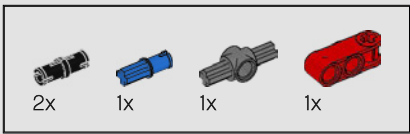

163

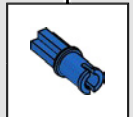
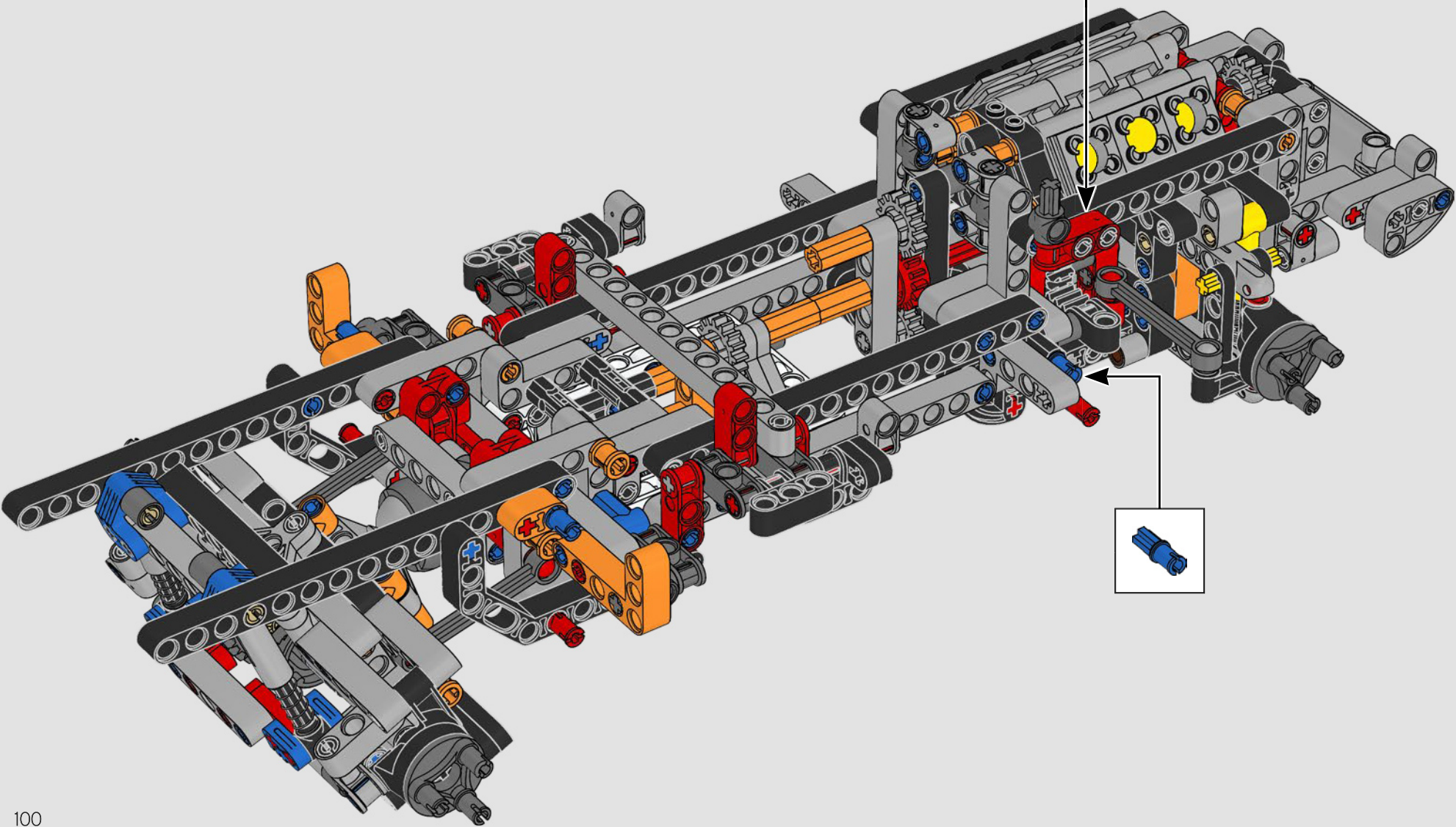
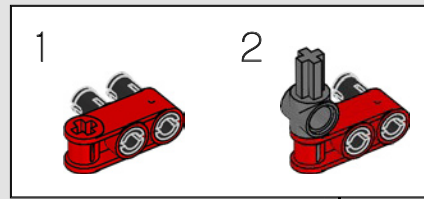

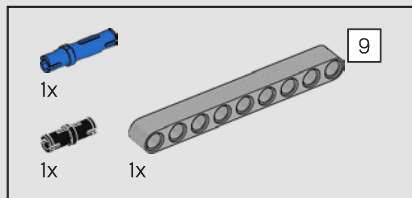

164

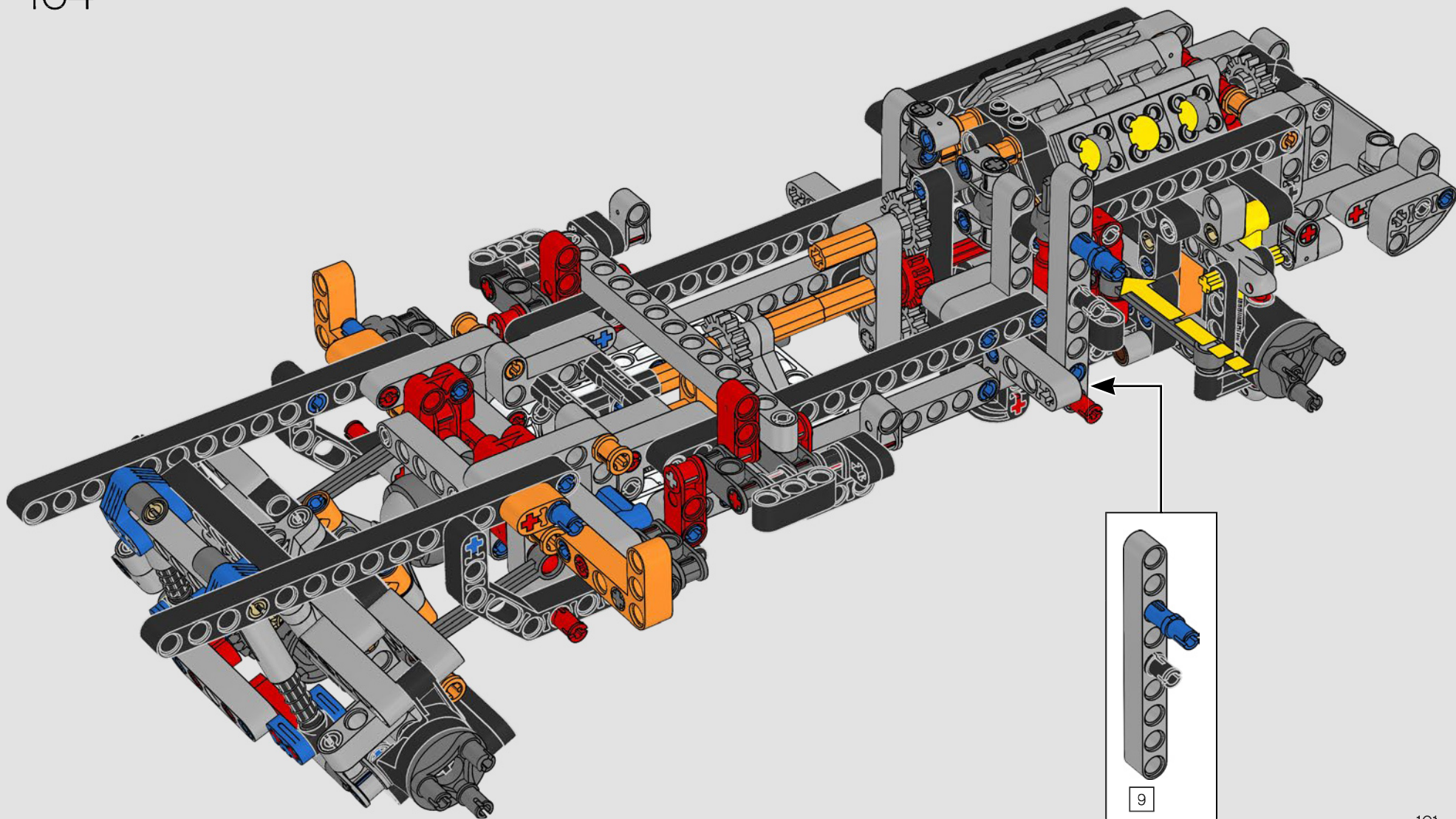

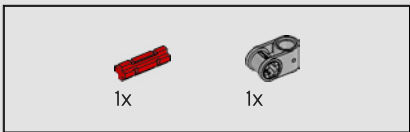

165

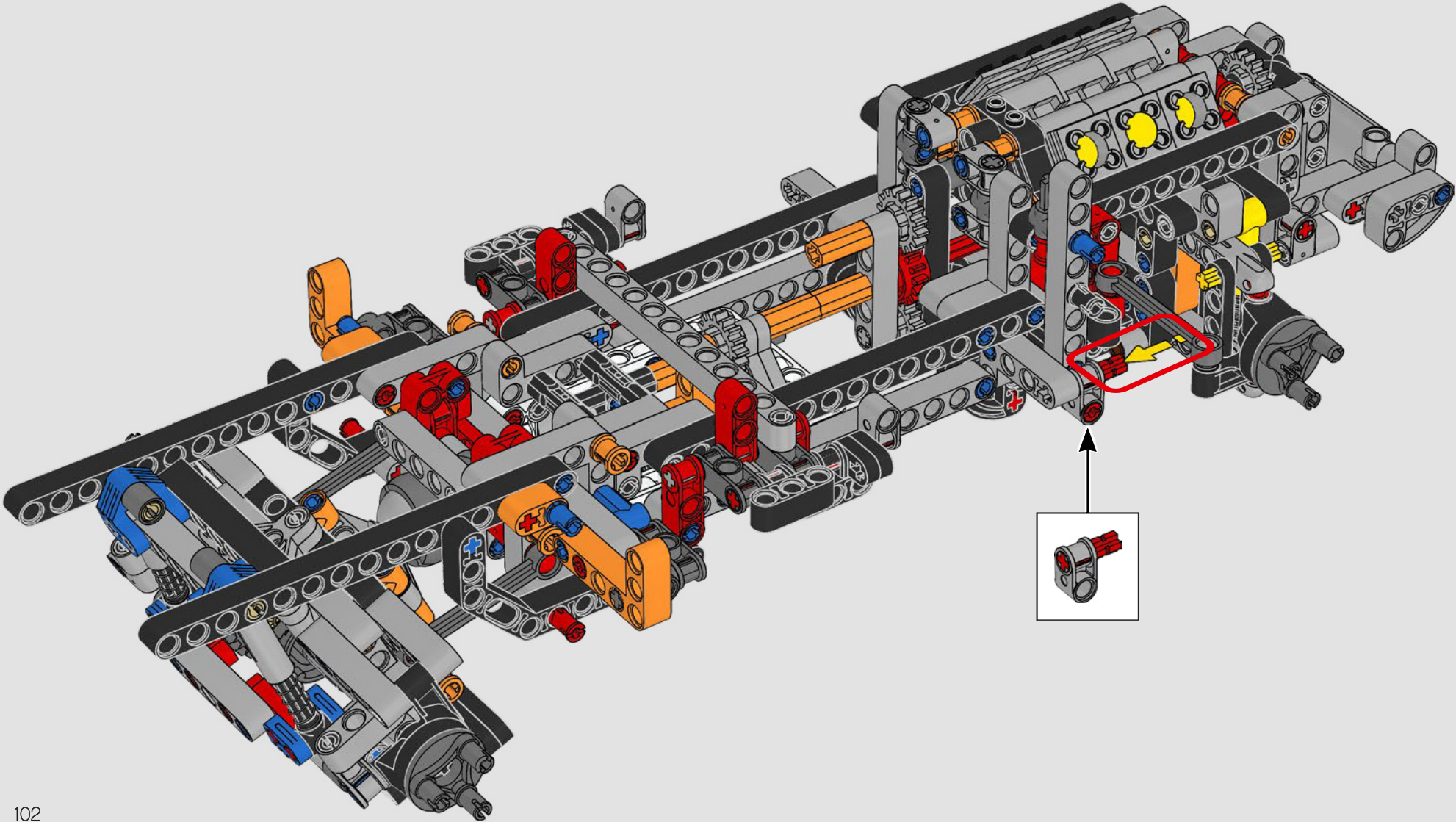

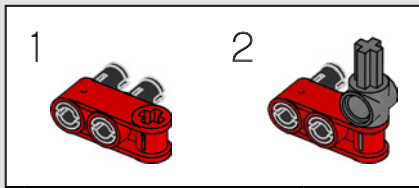
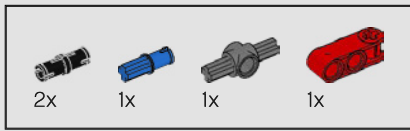

166

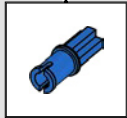
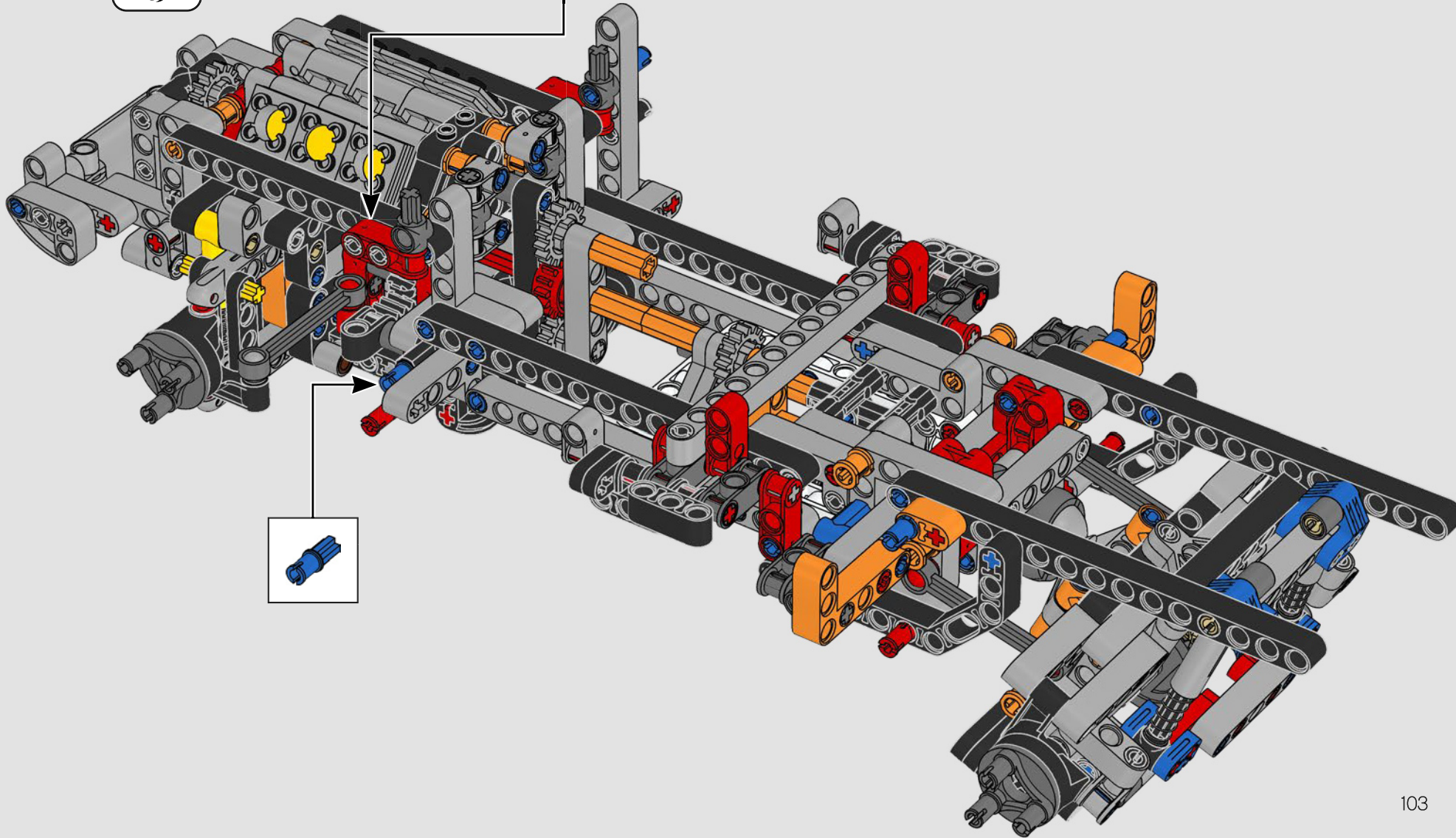

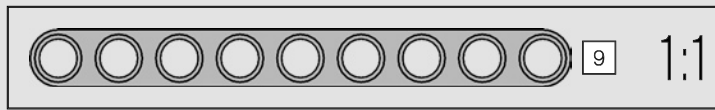
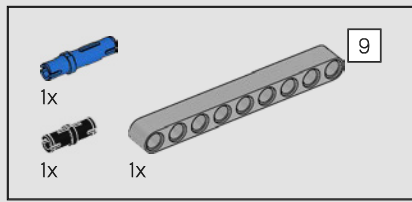

167

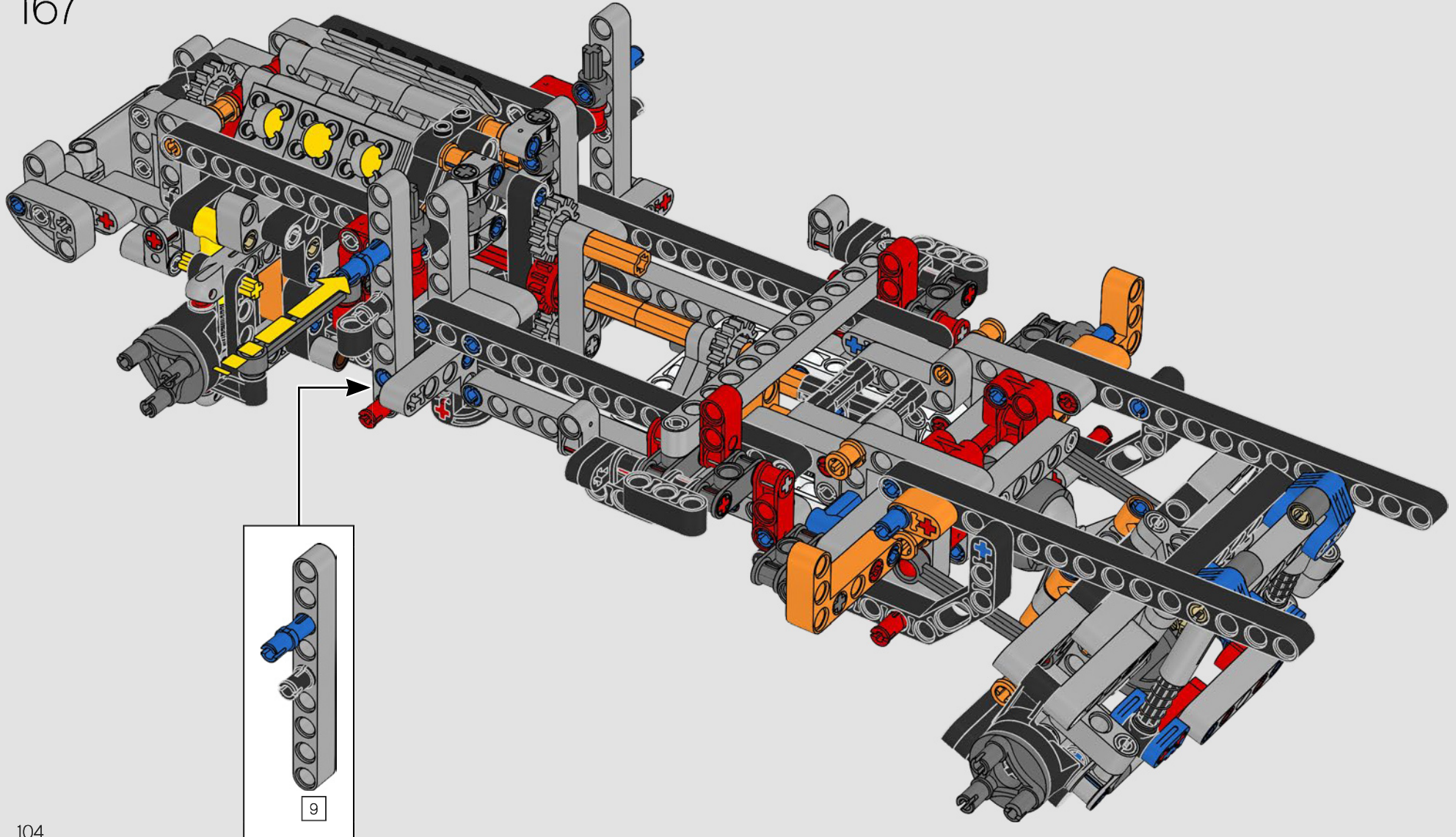

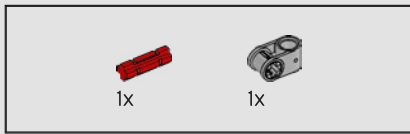

168

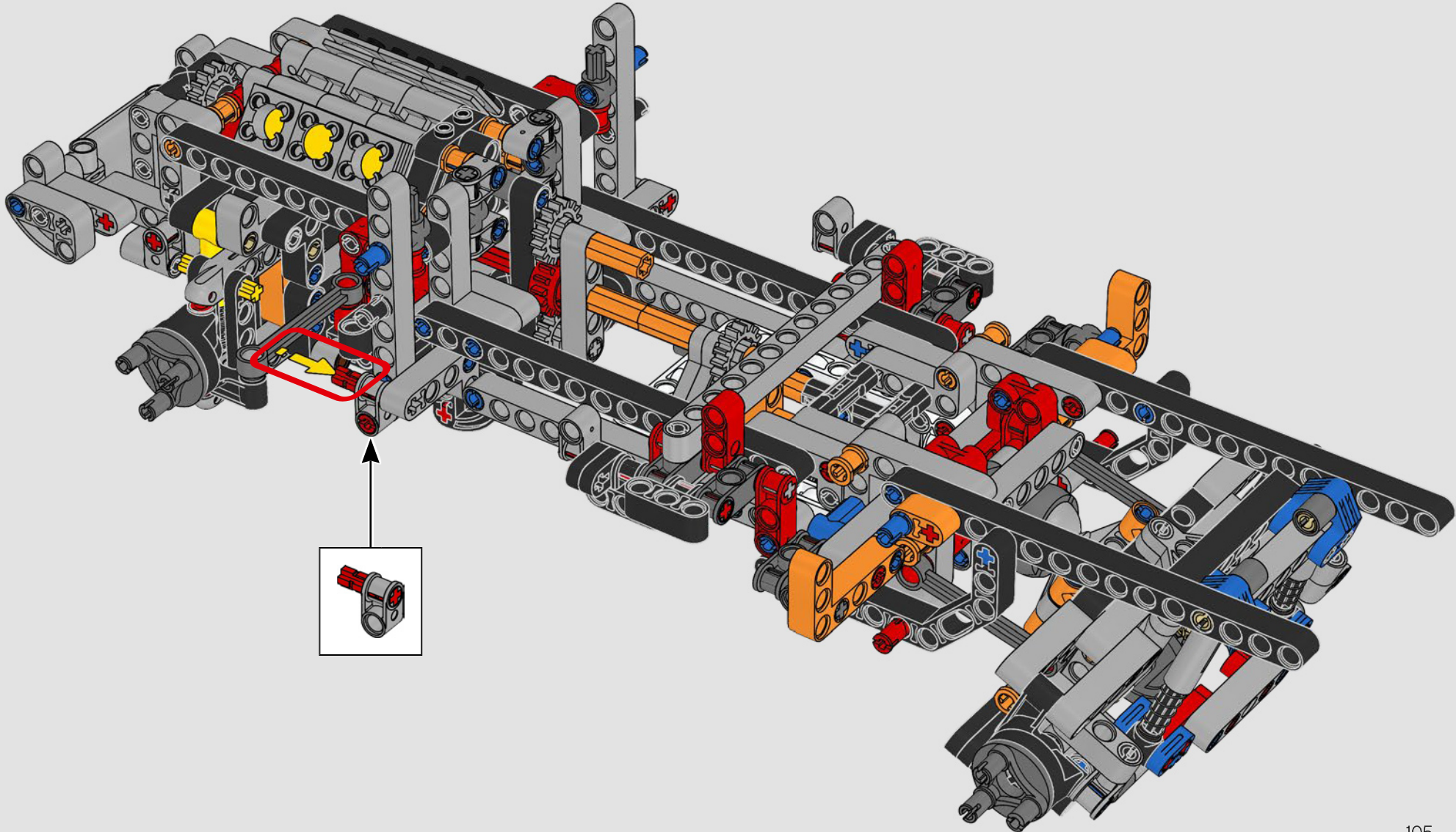

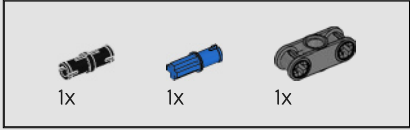
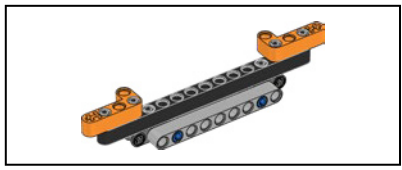

169

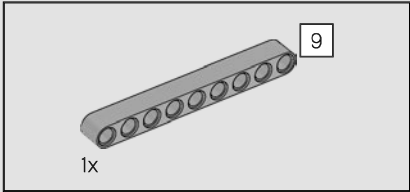
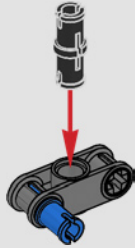

170

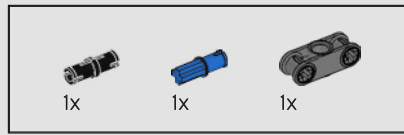
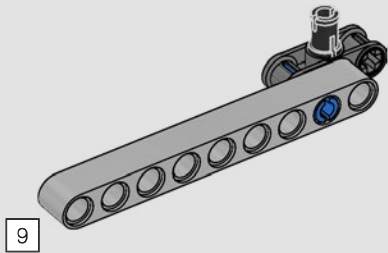

171

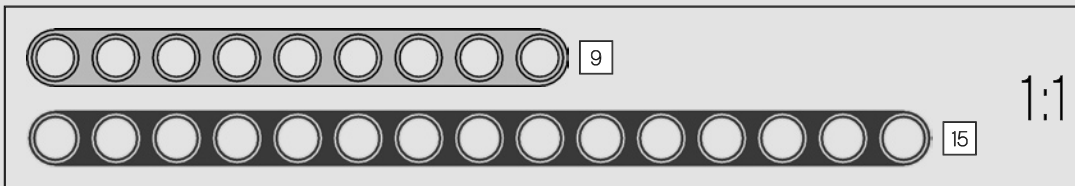
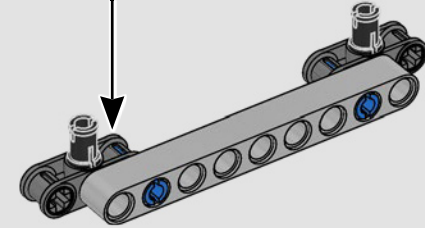
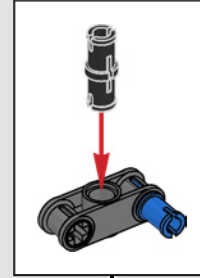

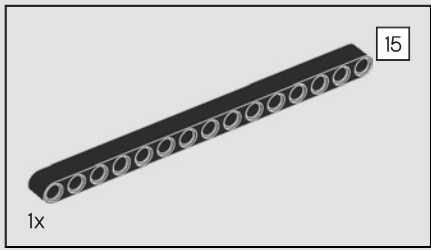

172

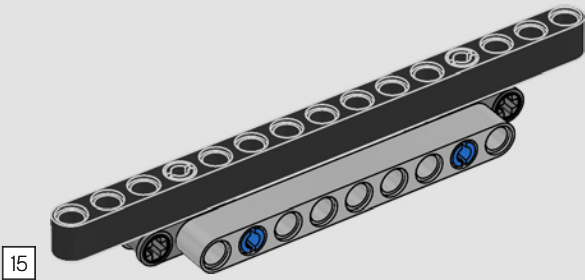

173

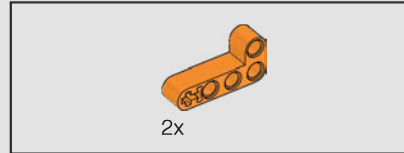
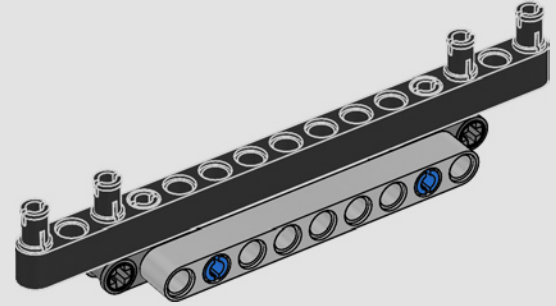

174

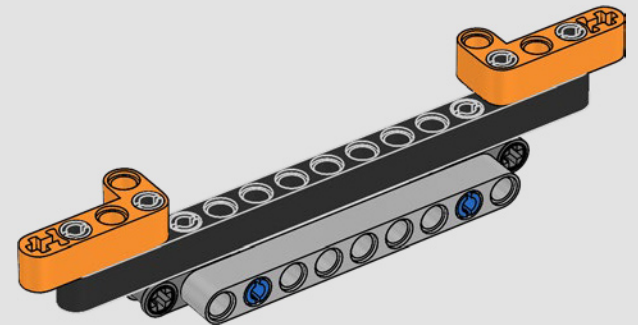

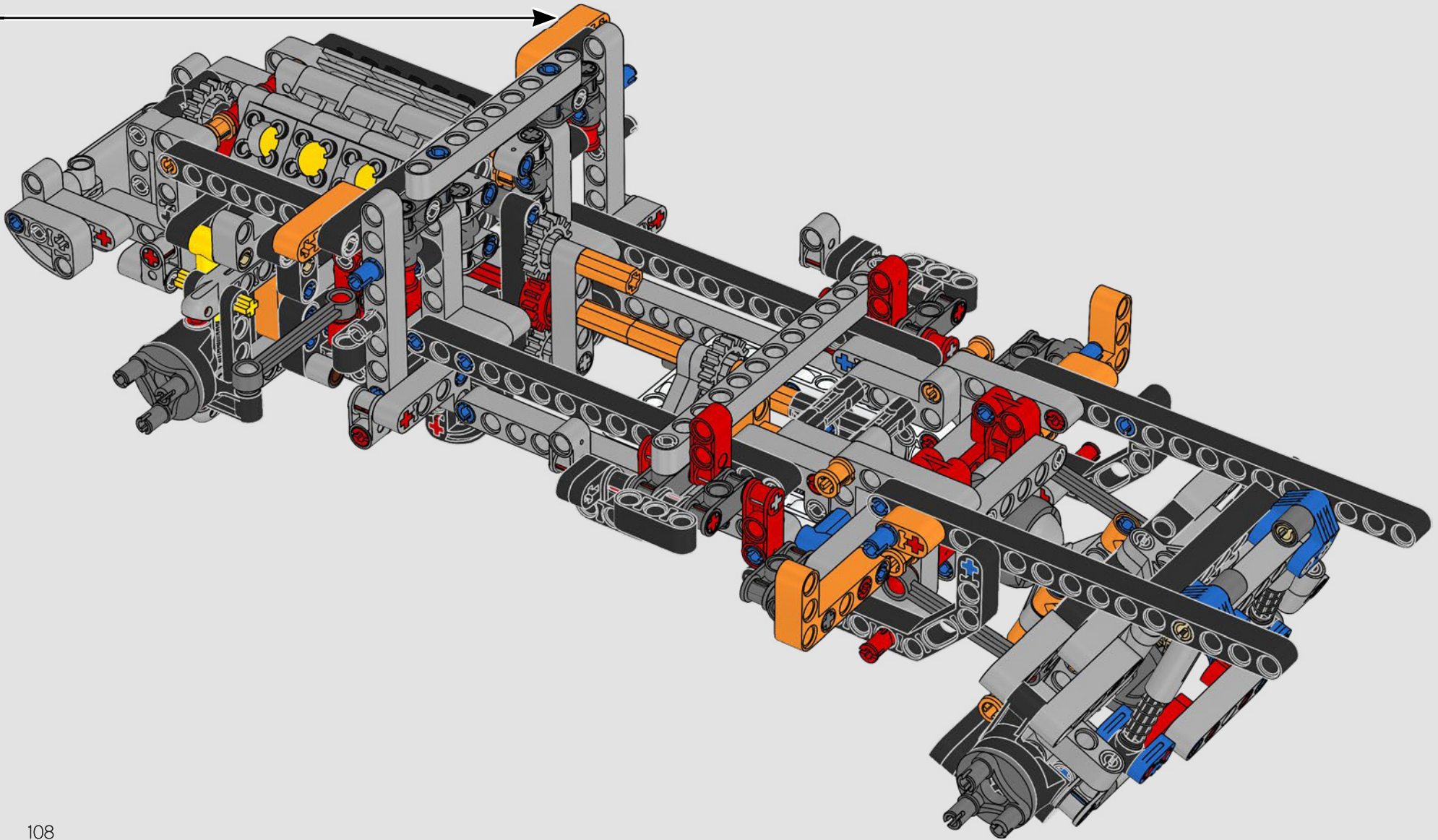



176

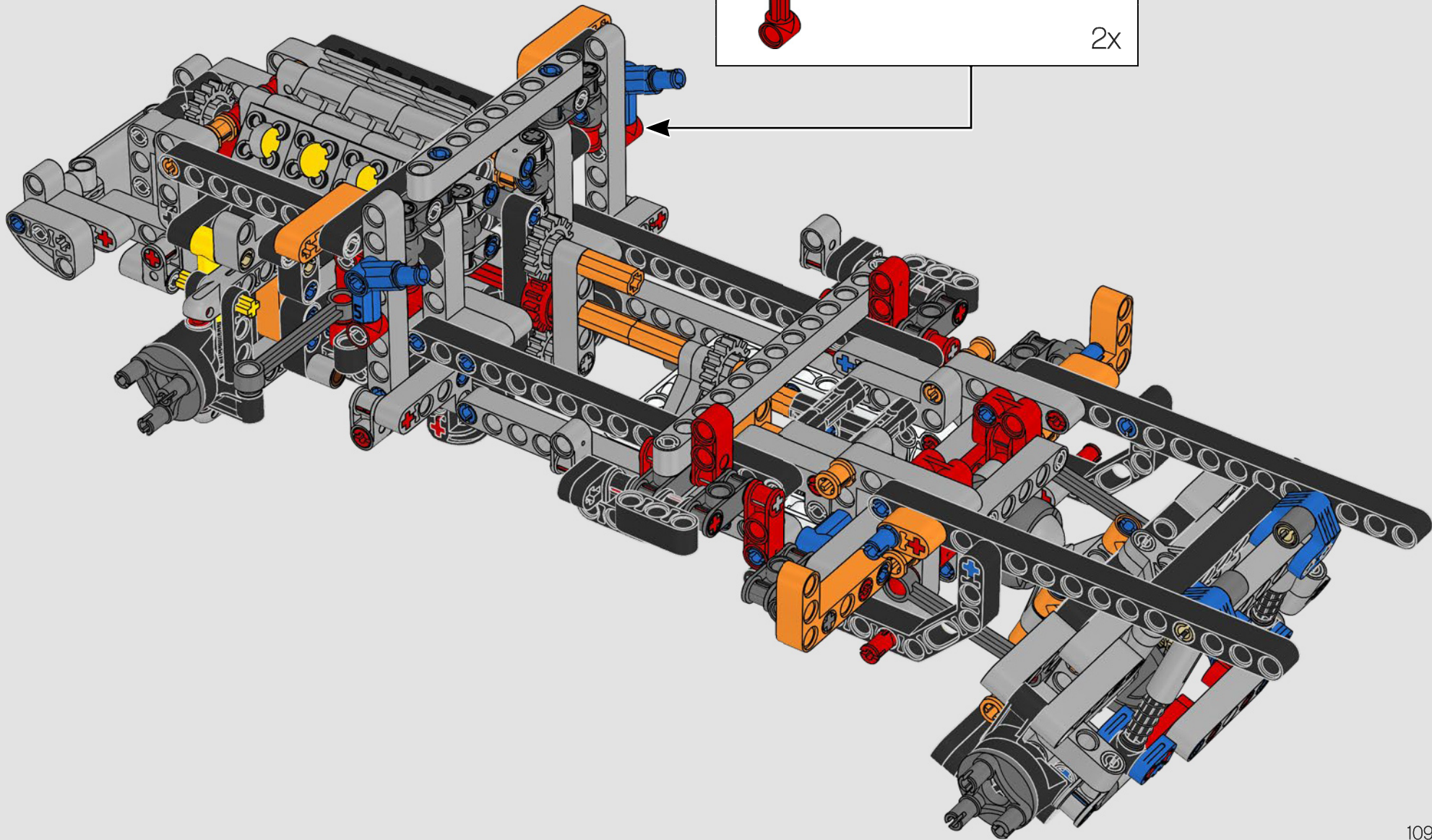
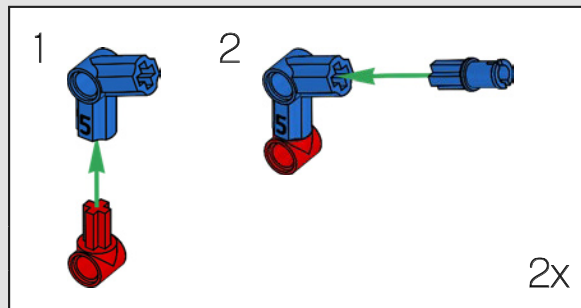

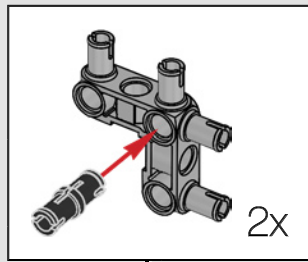
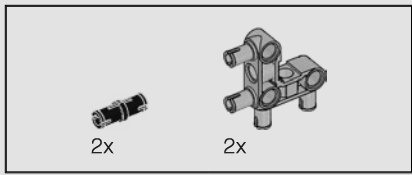

177

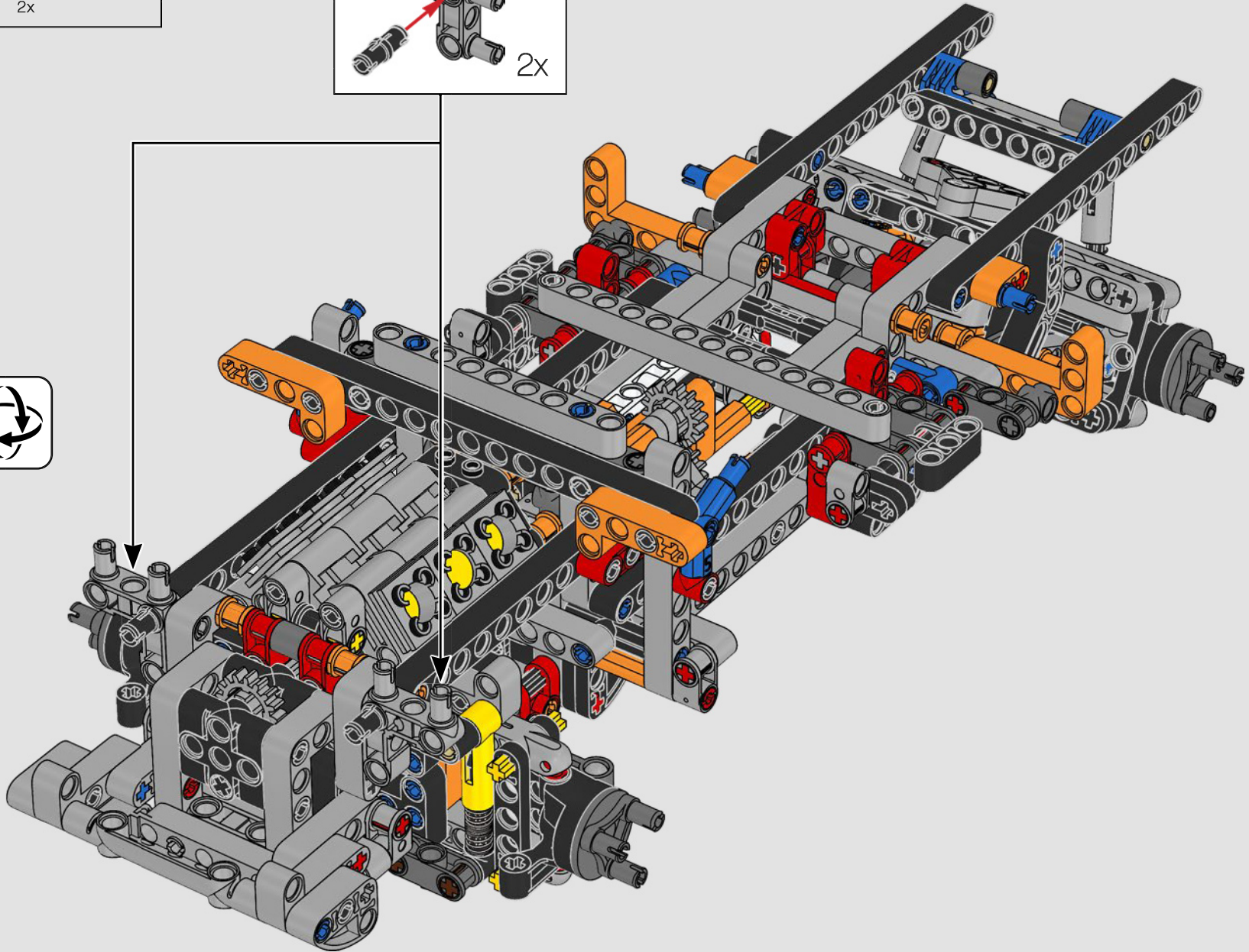

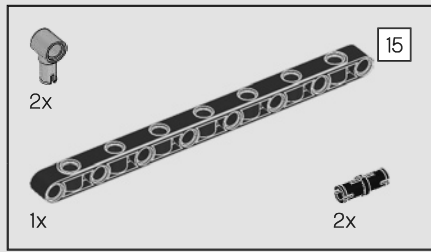

178

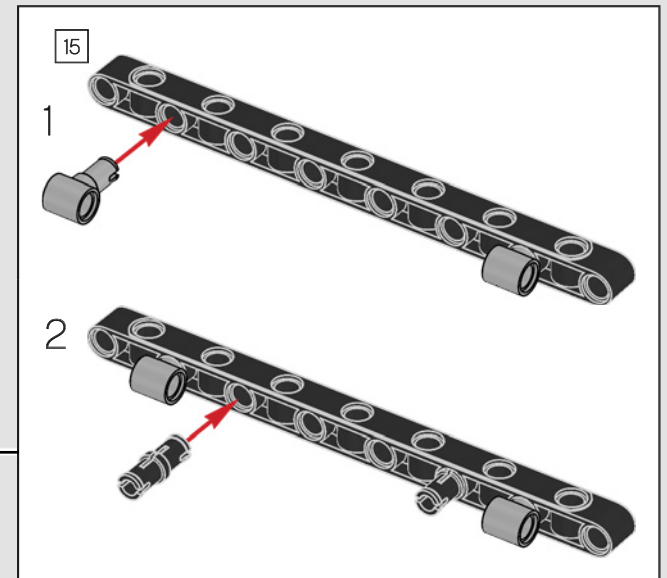
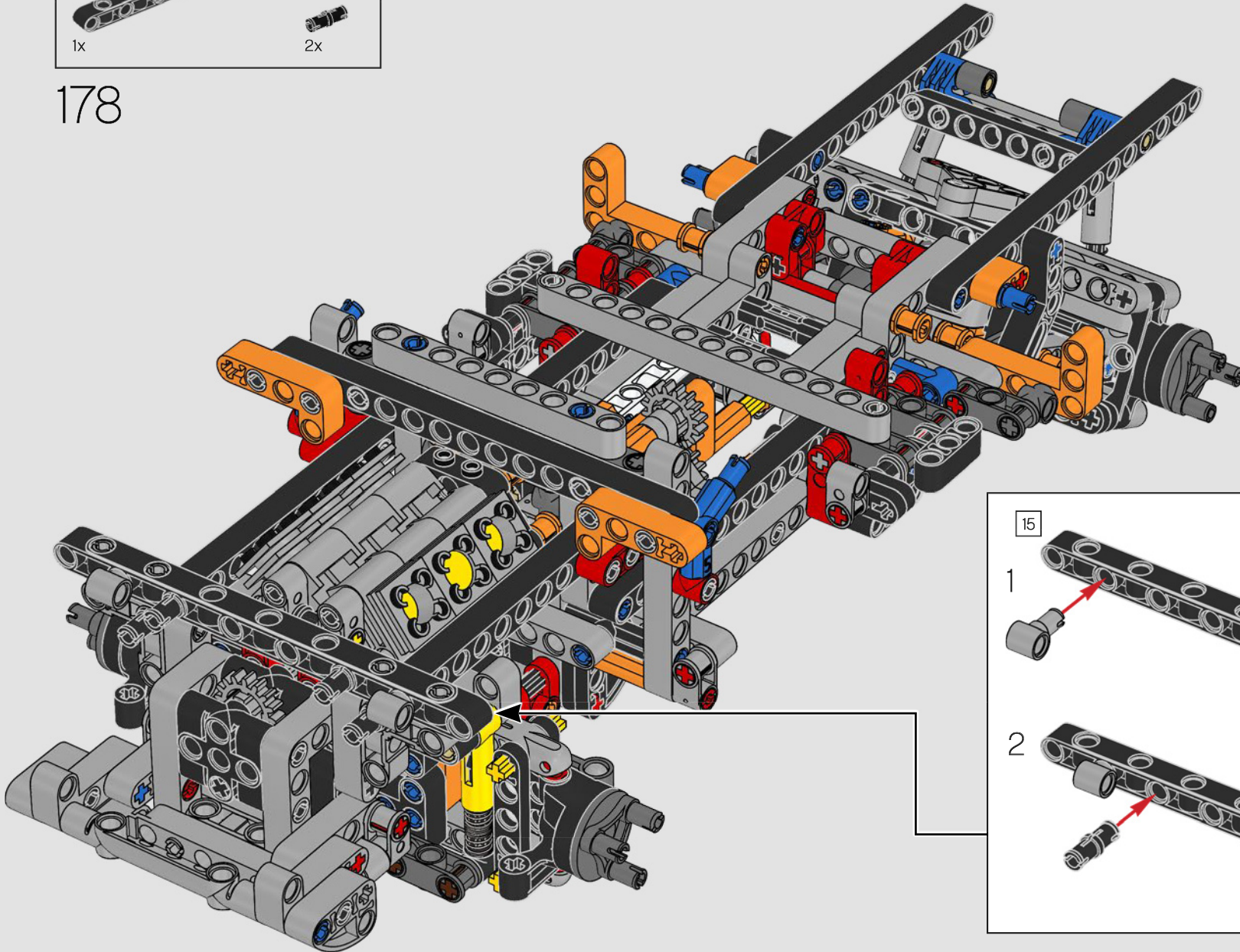

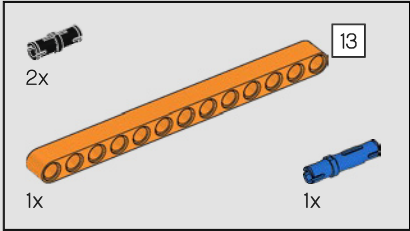
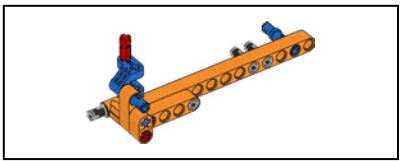

179

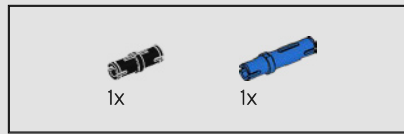
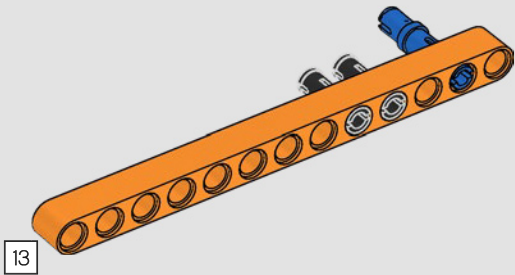

180

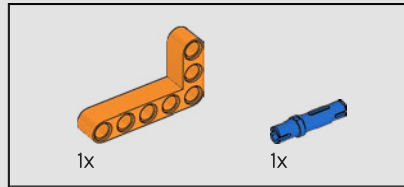
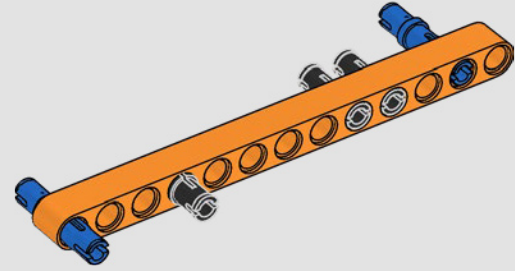

181

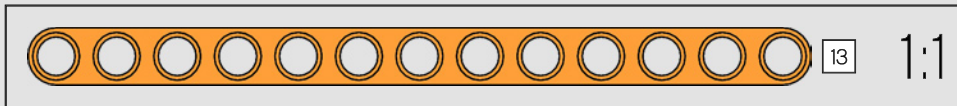
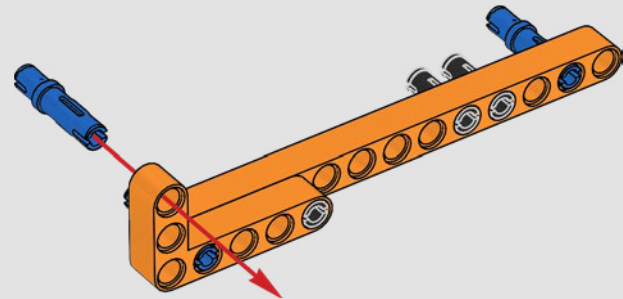

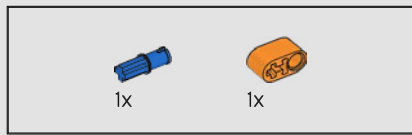

182

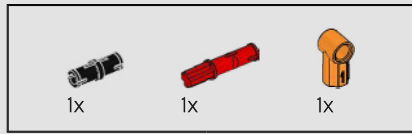
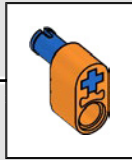
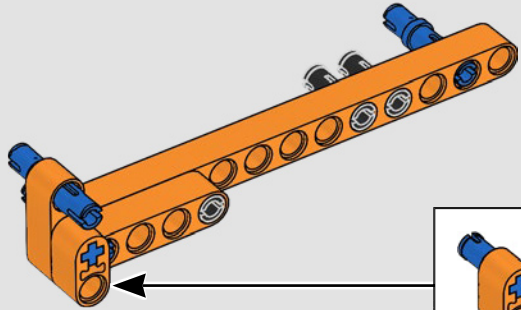

183

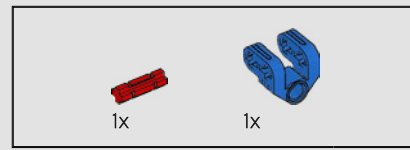
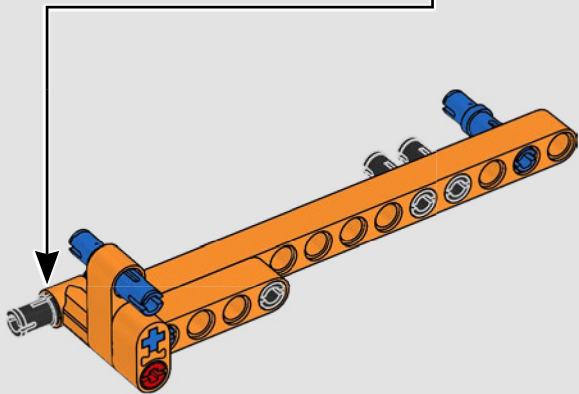
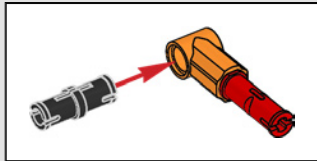

184

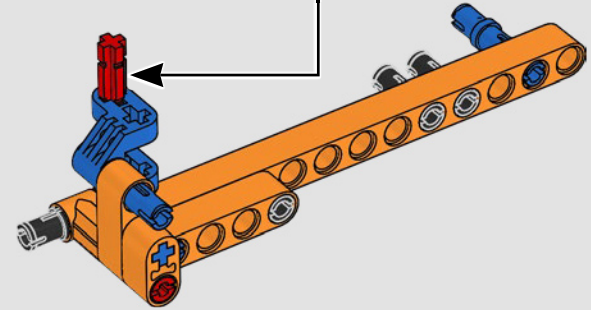
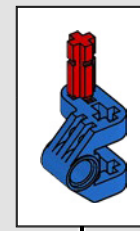

185

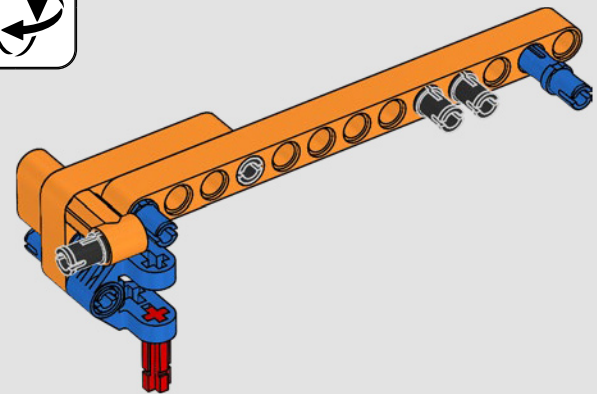

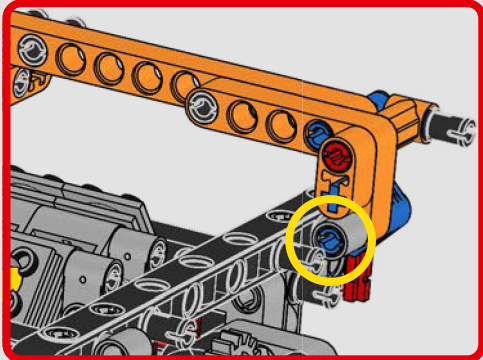
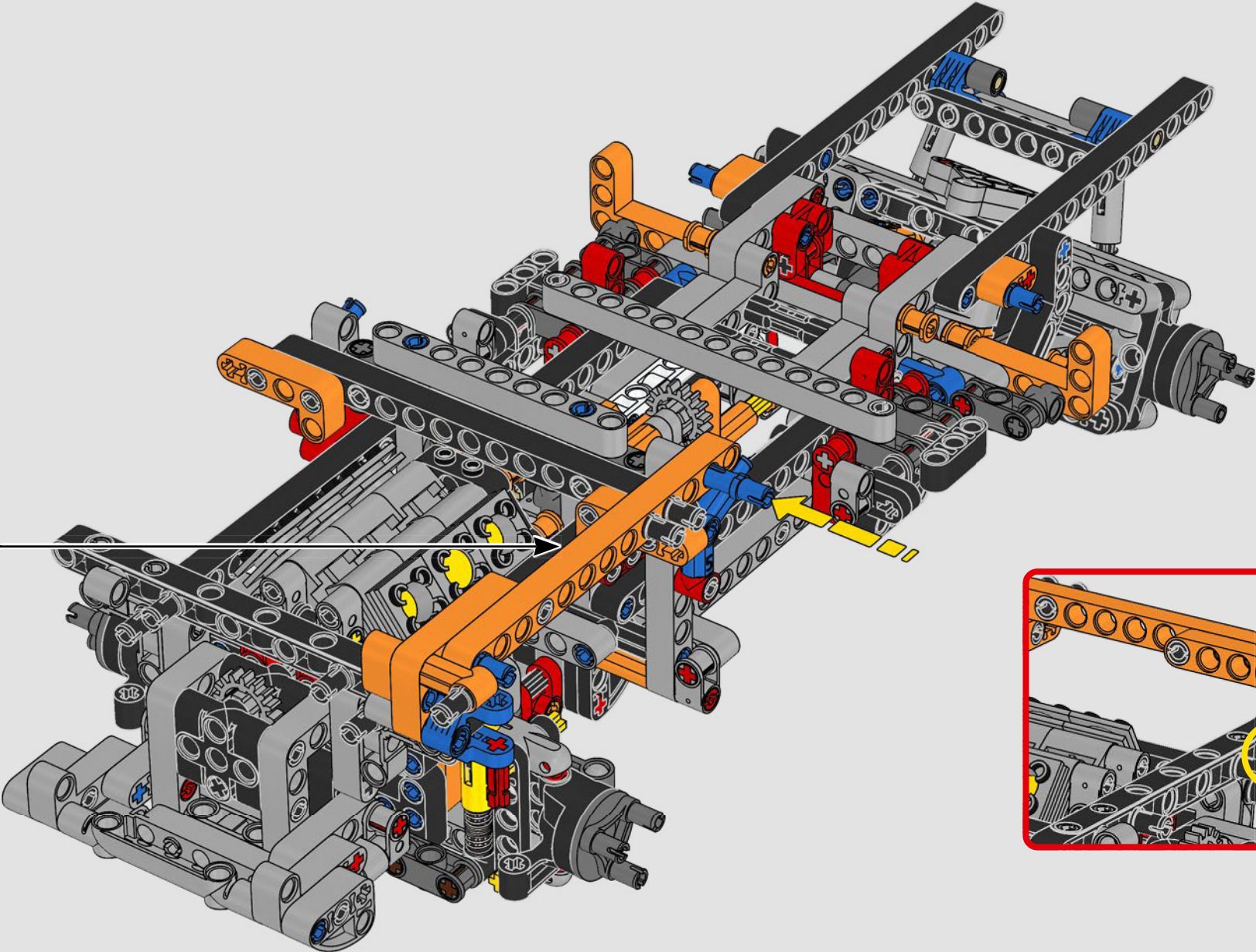

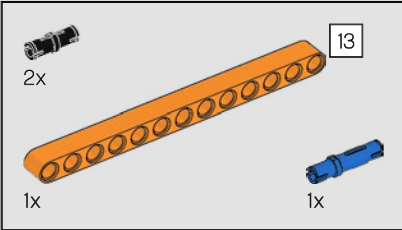
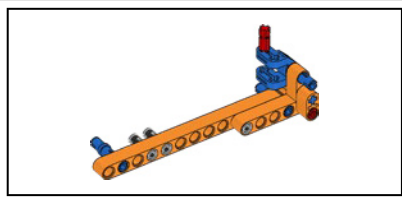

187

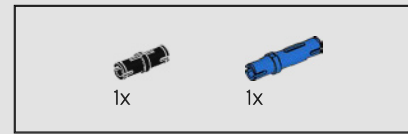
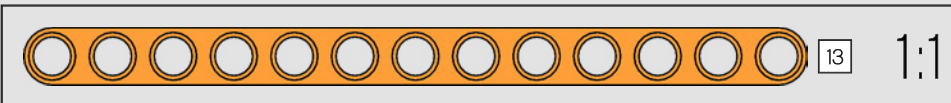
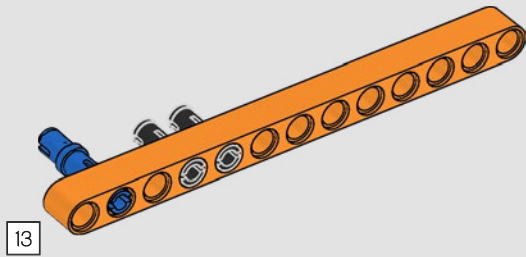

188

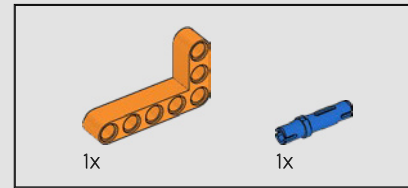
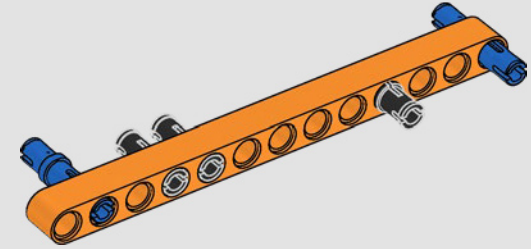

189

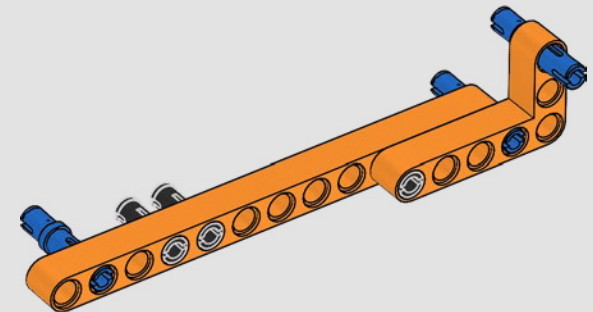

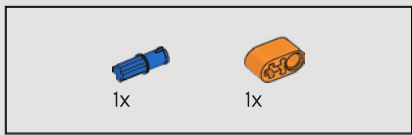

190

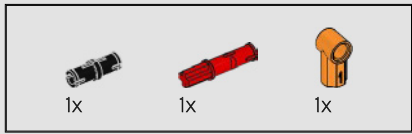
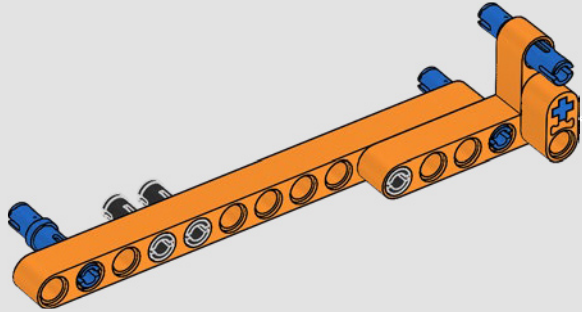

191

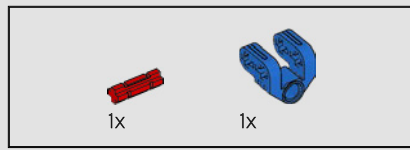
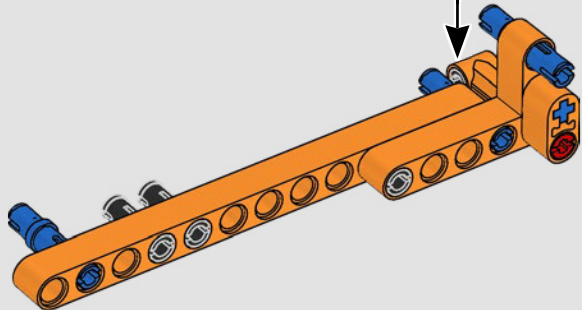
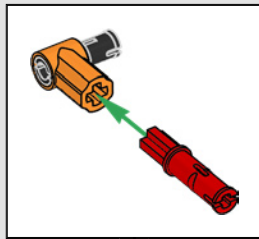

192

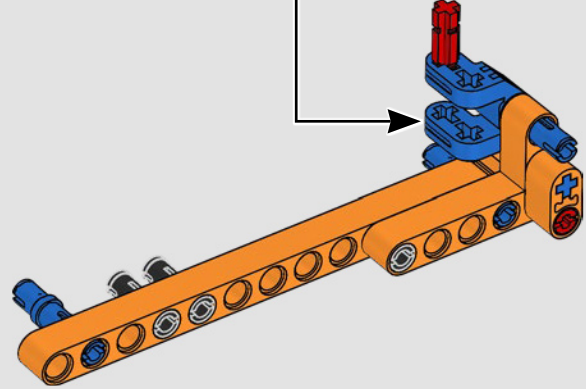
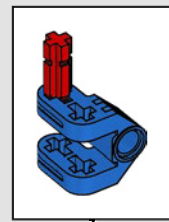

193

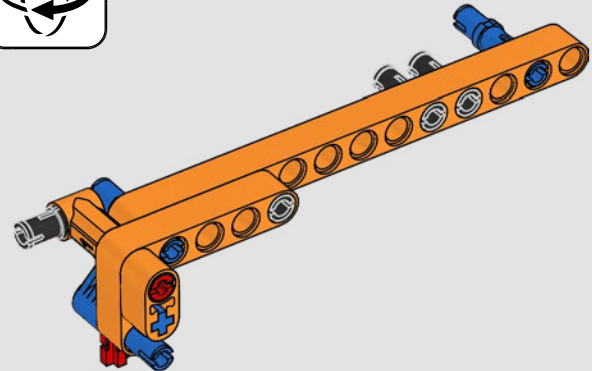
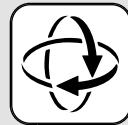

194

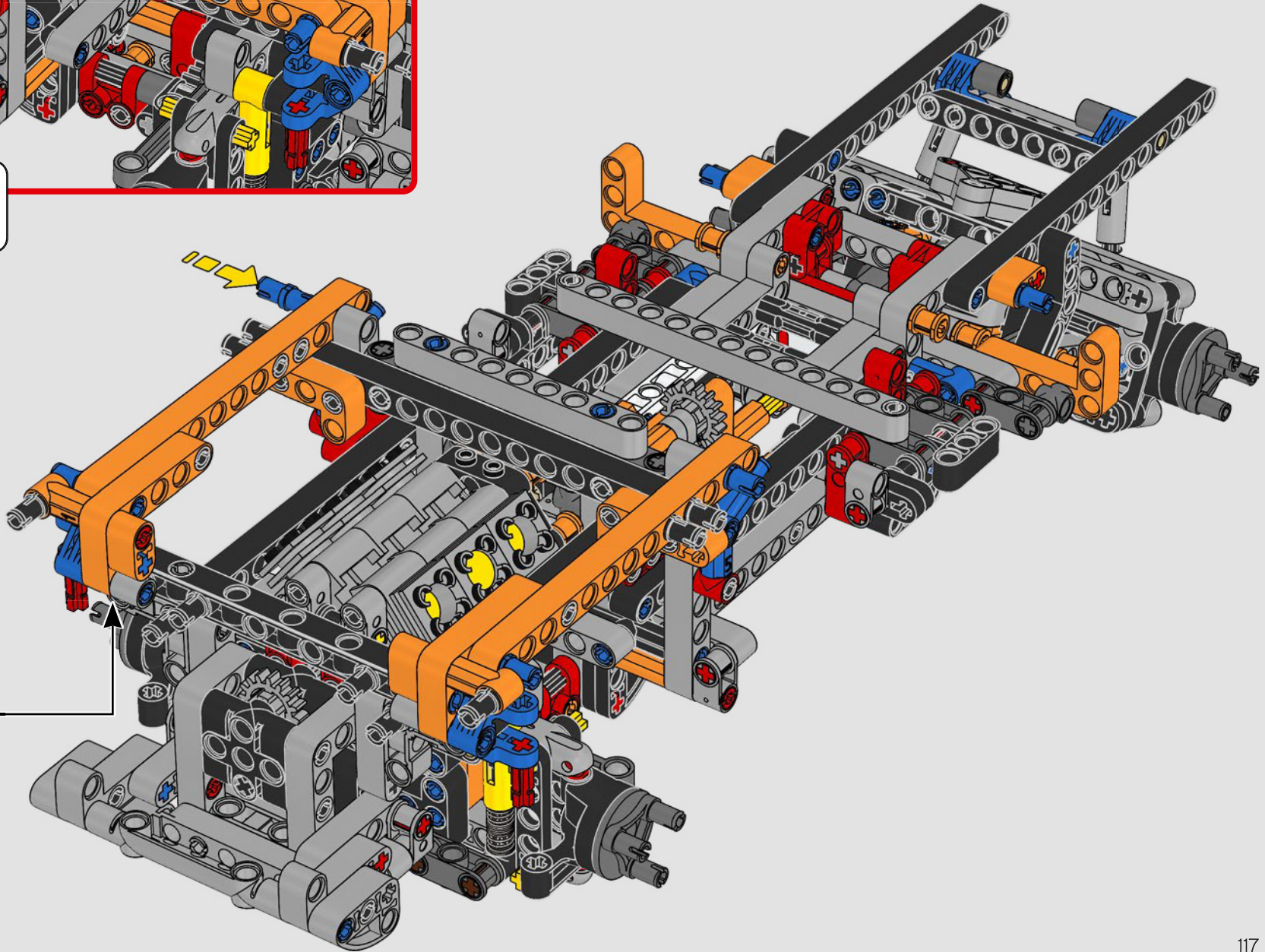
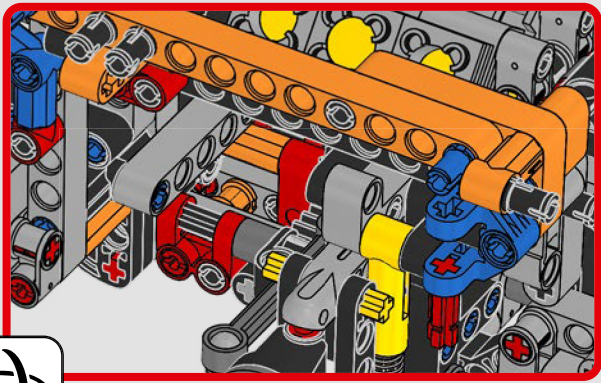

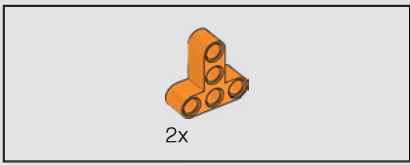

195

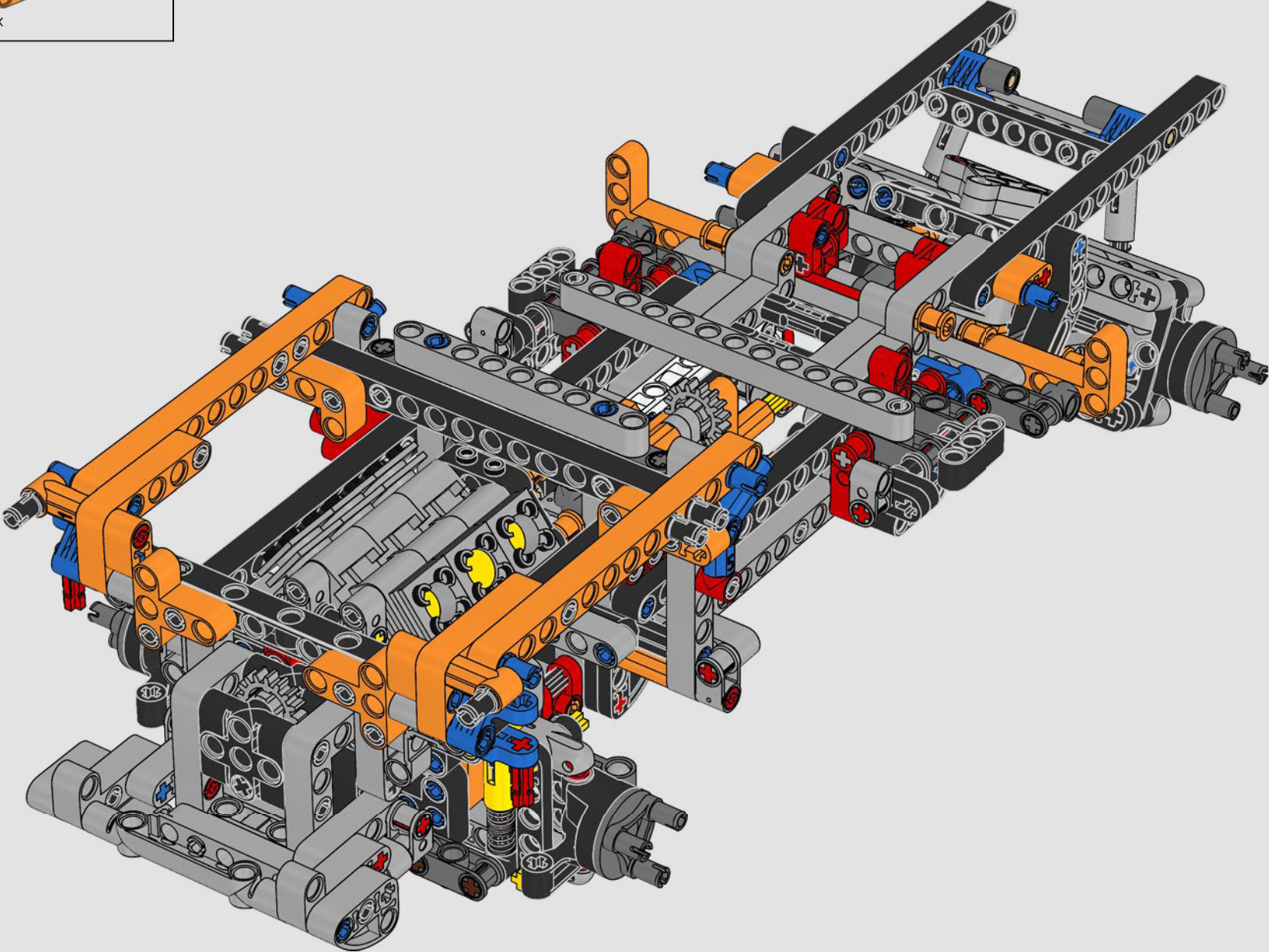



196

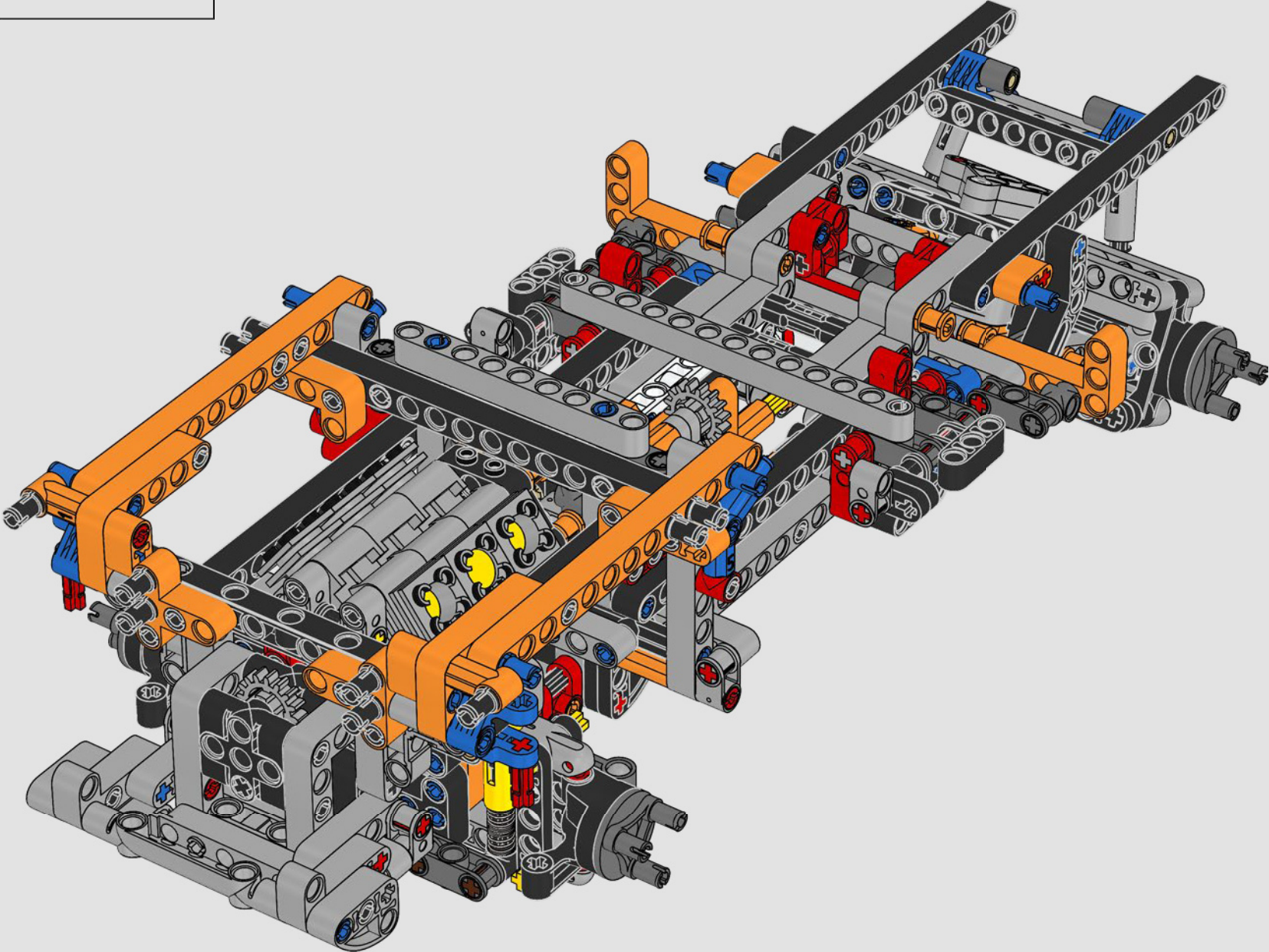

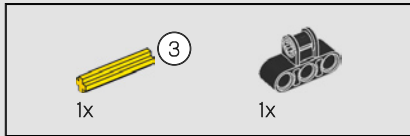
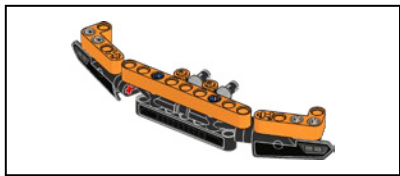

197

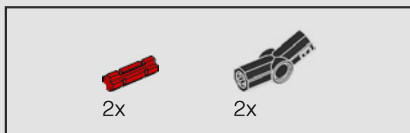

198

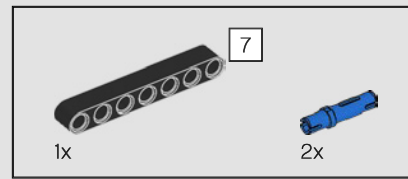
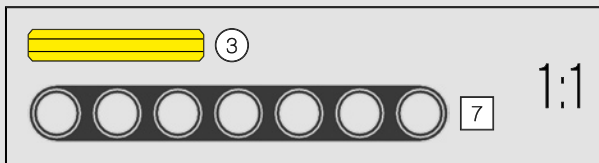
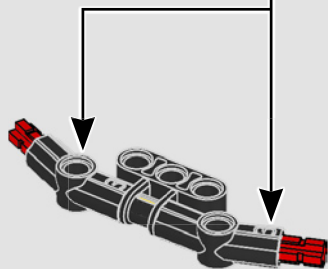
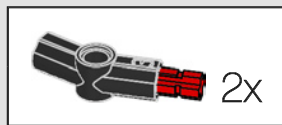

199

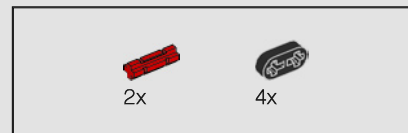
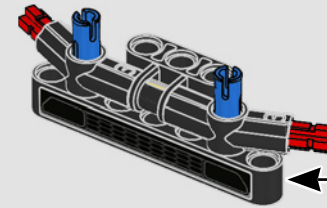
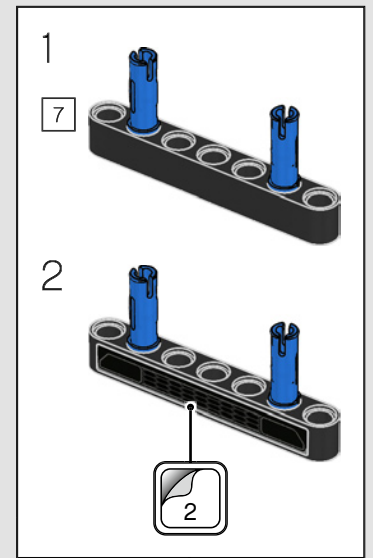

200

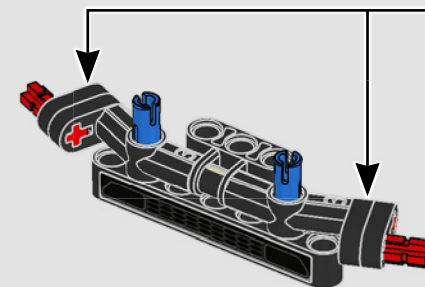
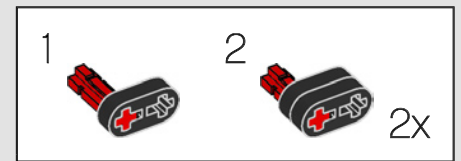

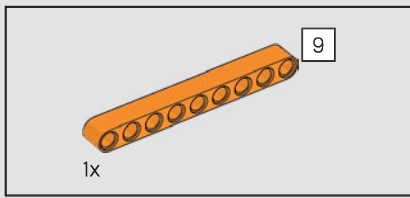

201

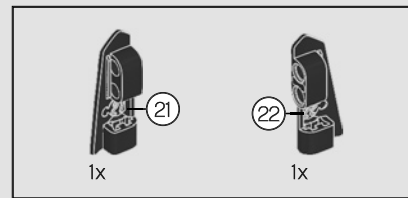
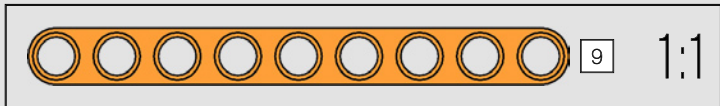
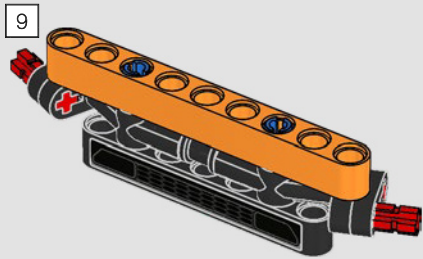

202

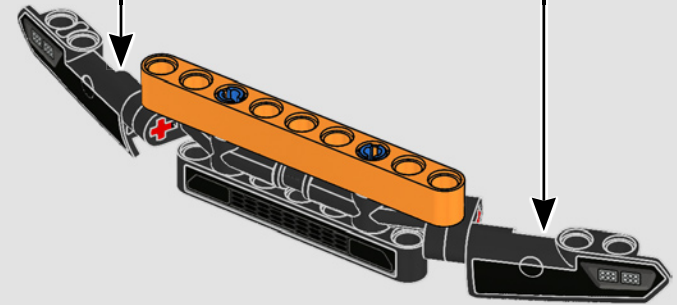
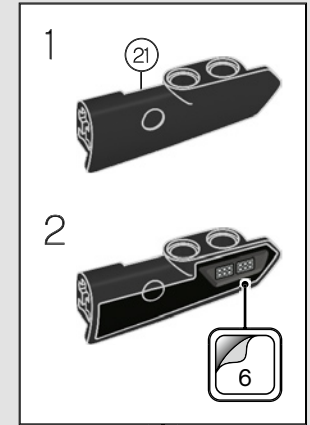
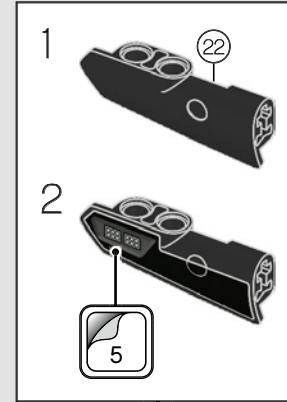



203

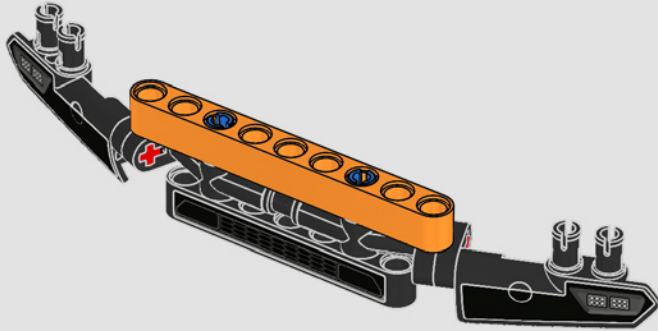

204

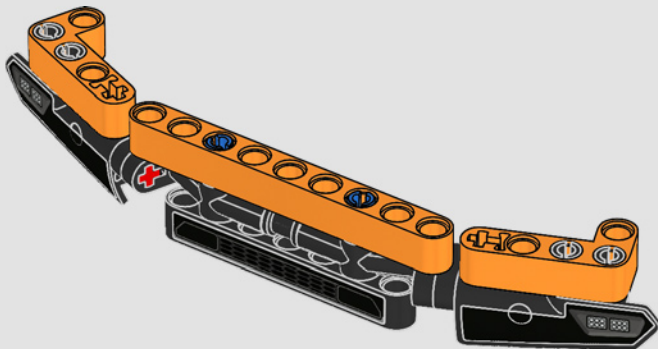

205

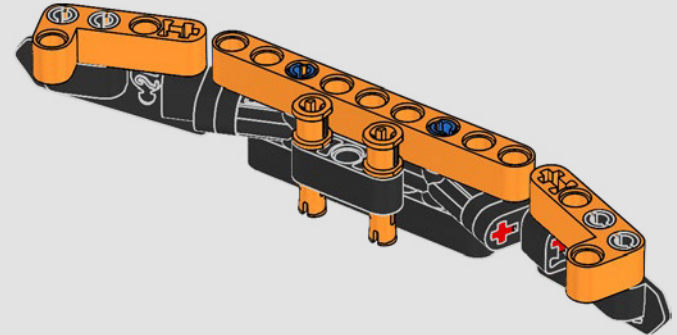
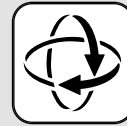

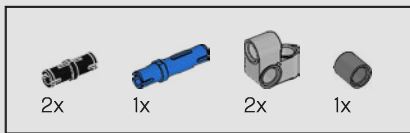

206

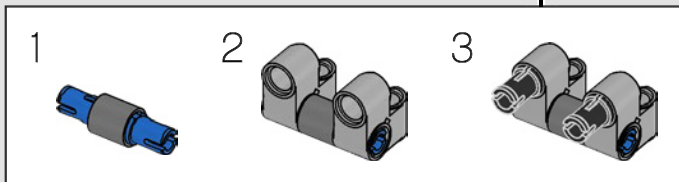
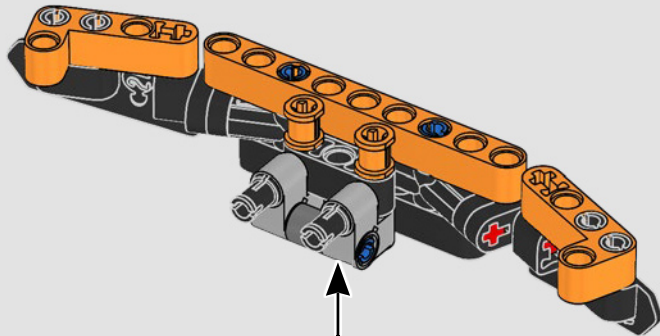

207

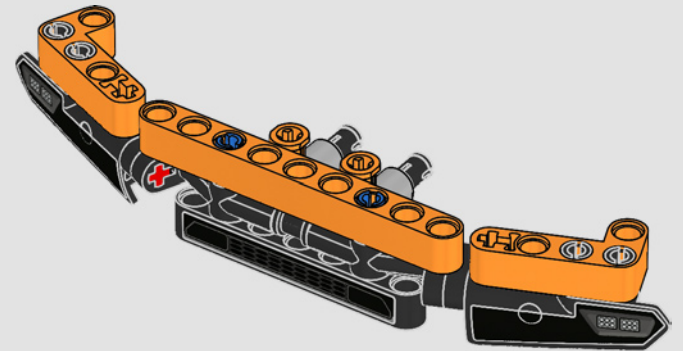
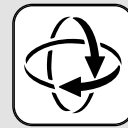

208

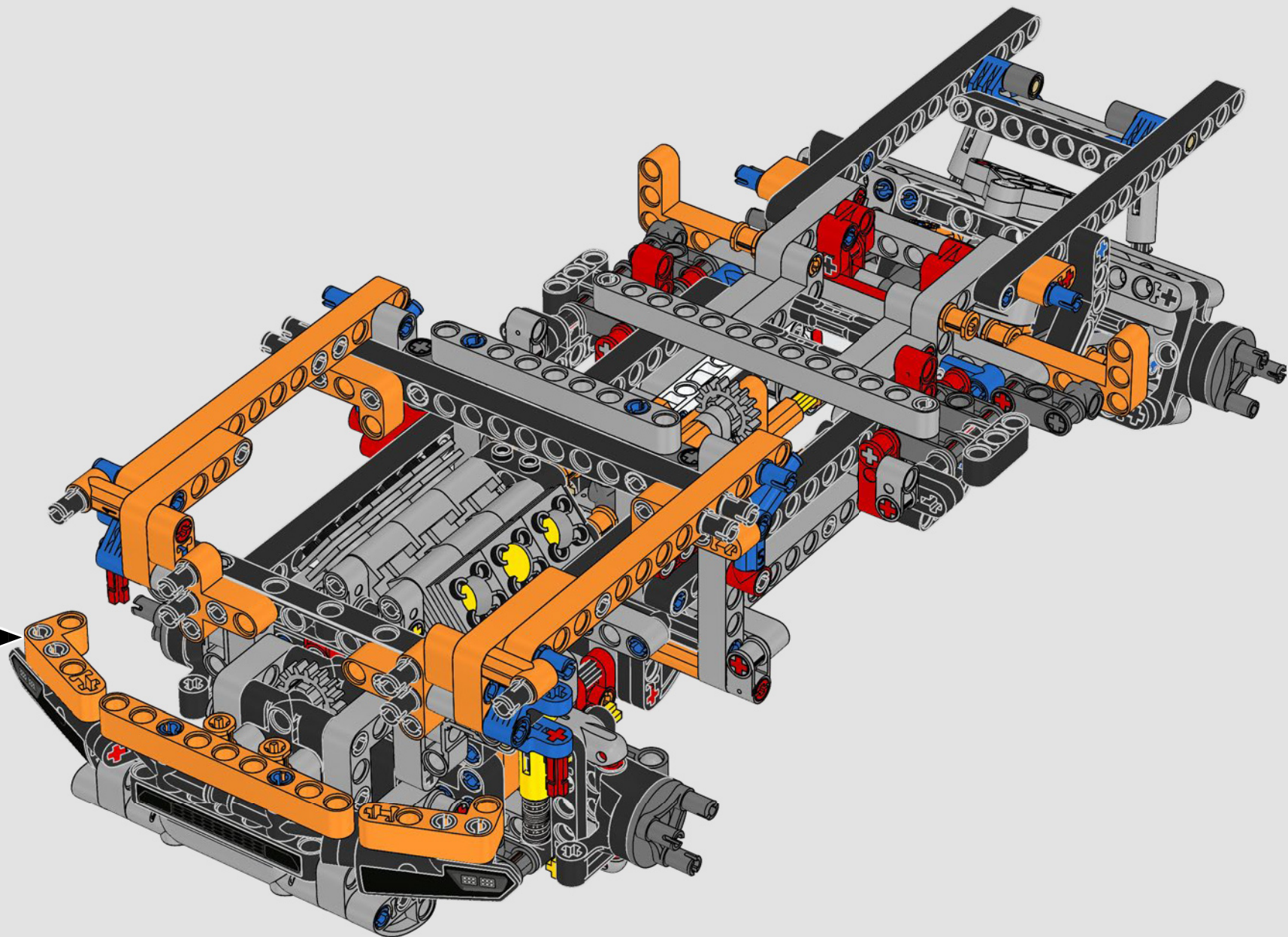

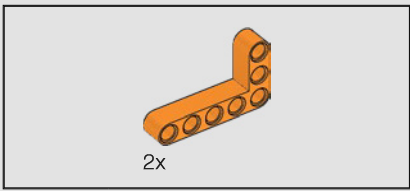

209

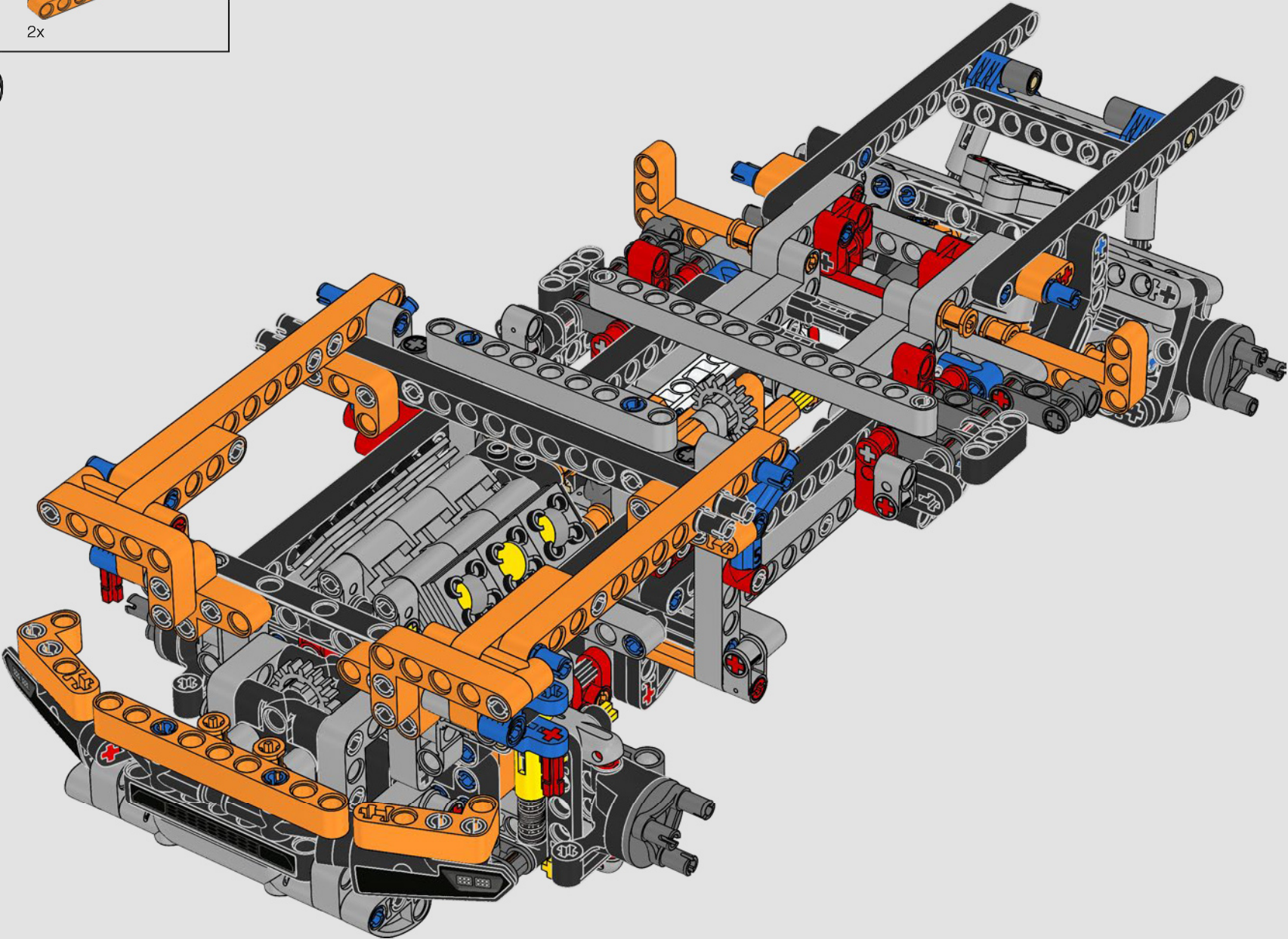

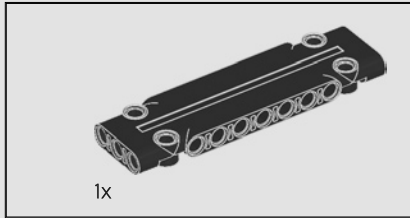
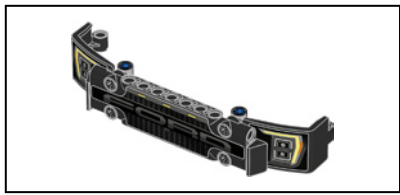

210

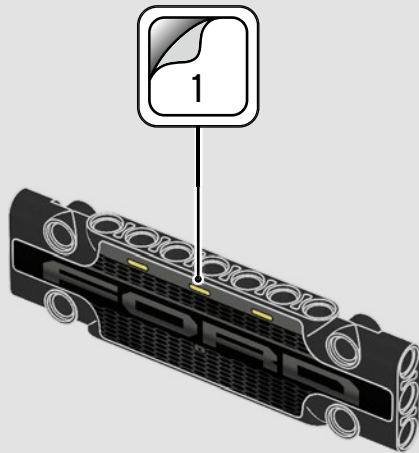

The Raptor is fitted with its own grille, replacing the Ford Blue Oval emblem with large "FORD" lettering.

La Raptor est dotée d'une calandre unique, l'inscription « FORD » en grosses lettres remplaçant le logo ovale bleu de Ford.

La Raptor cuenta con su propia parrilla, en la que el clásico óvalo azul del logotipo de Ford da paso a cuatro grandes letras: "FORD".



211

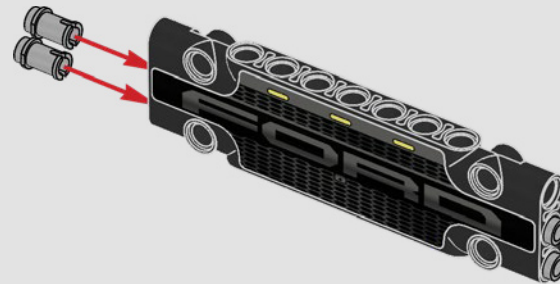

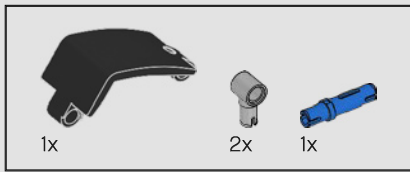

212

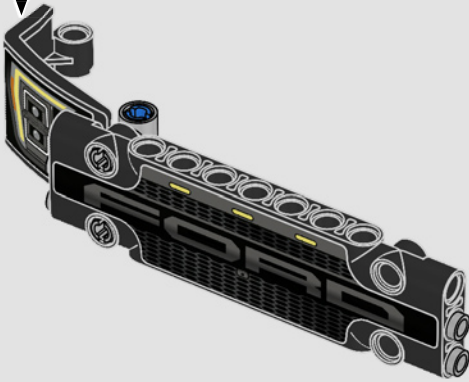
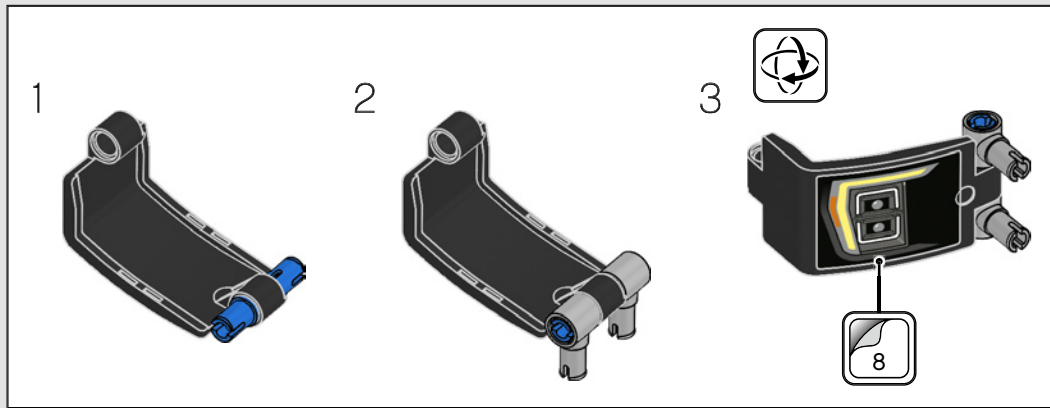

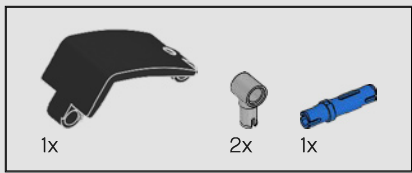

213

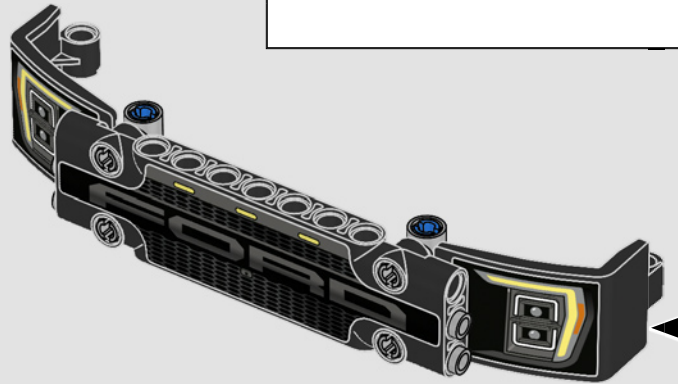
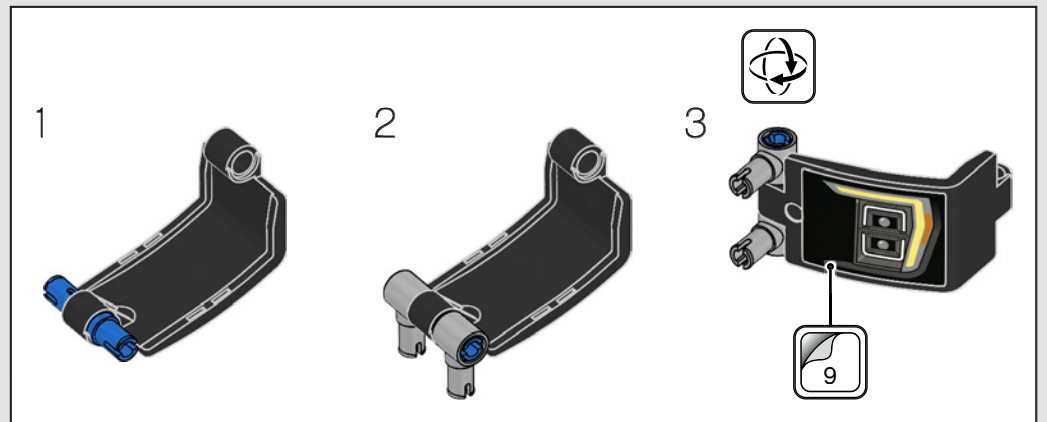

214

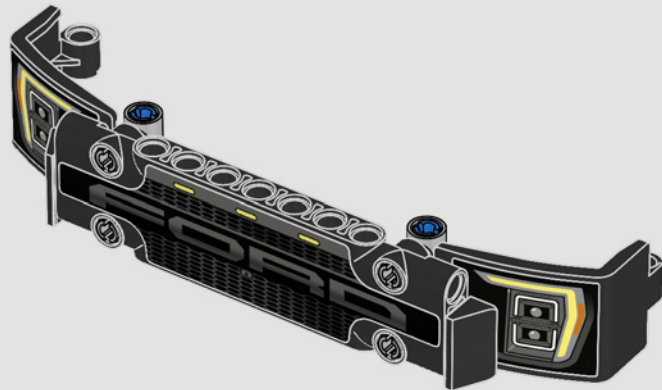

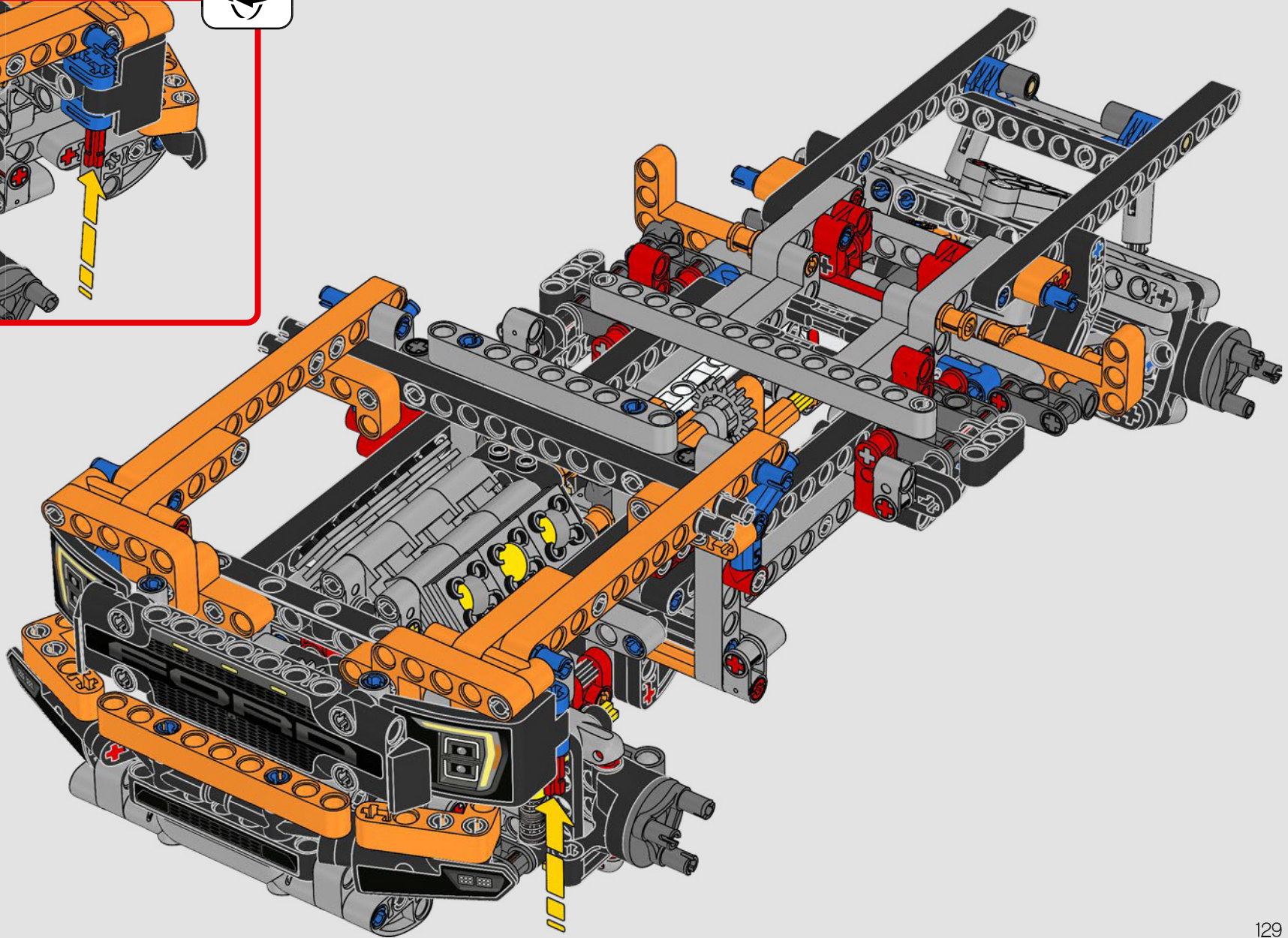
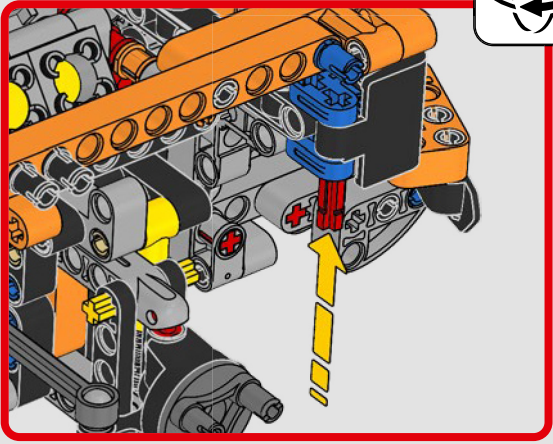

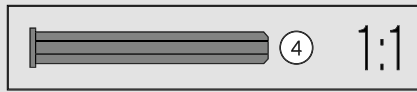
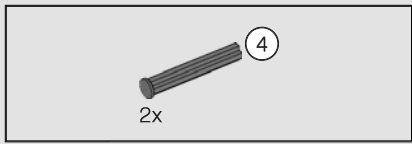

216

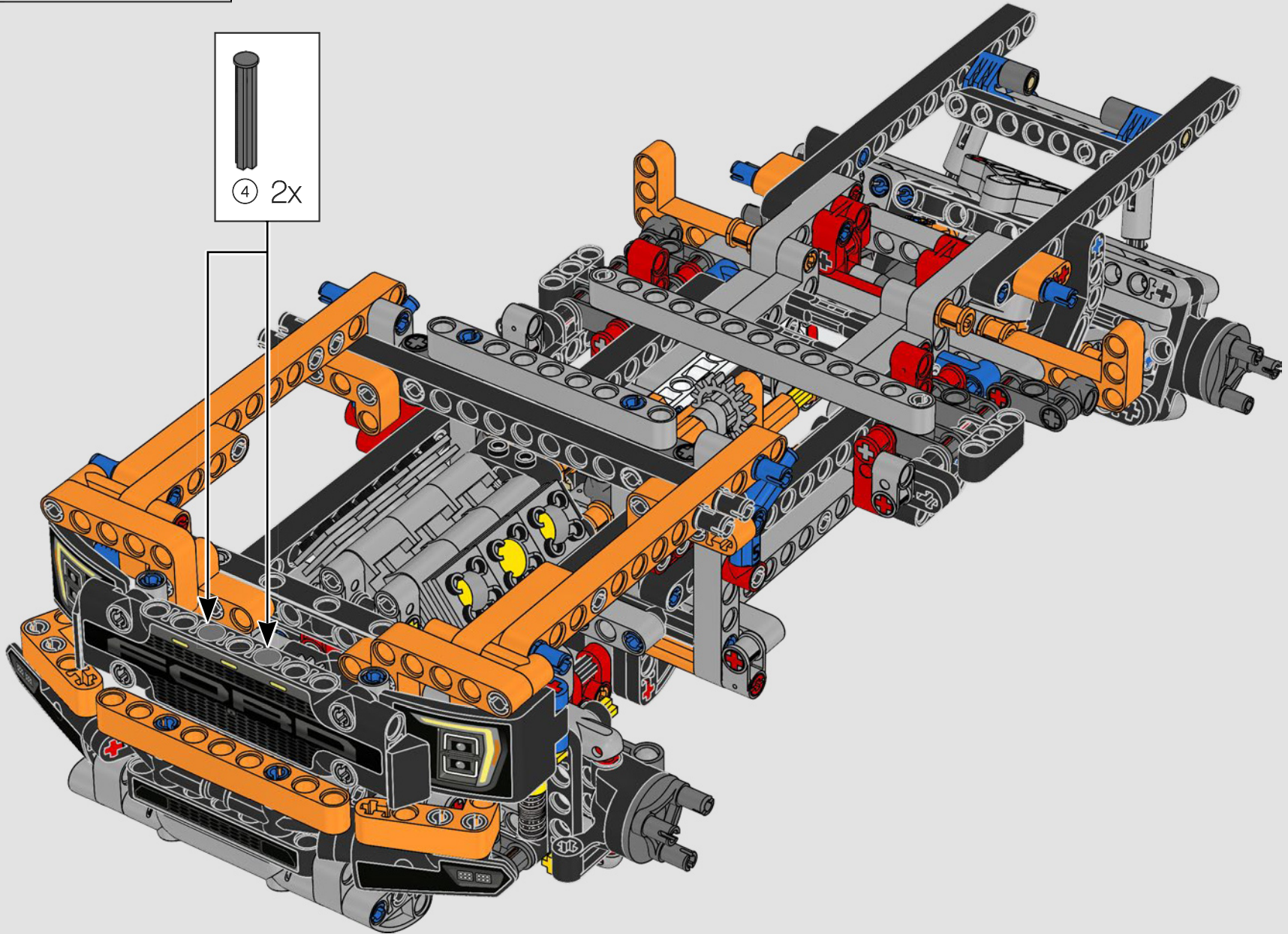
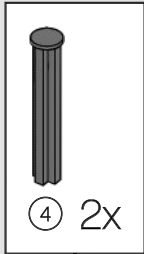

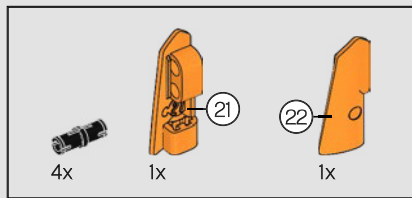

217

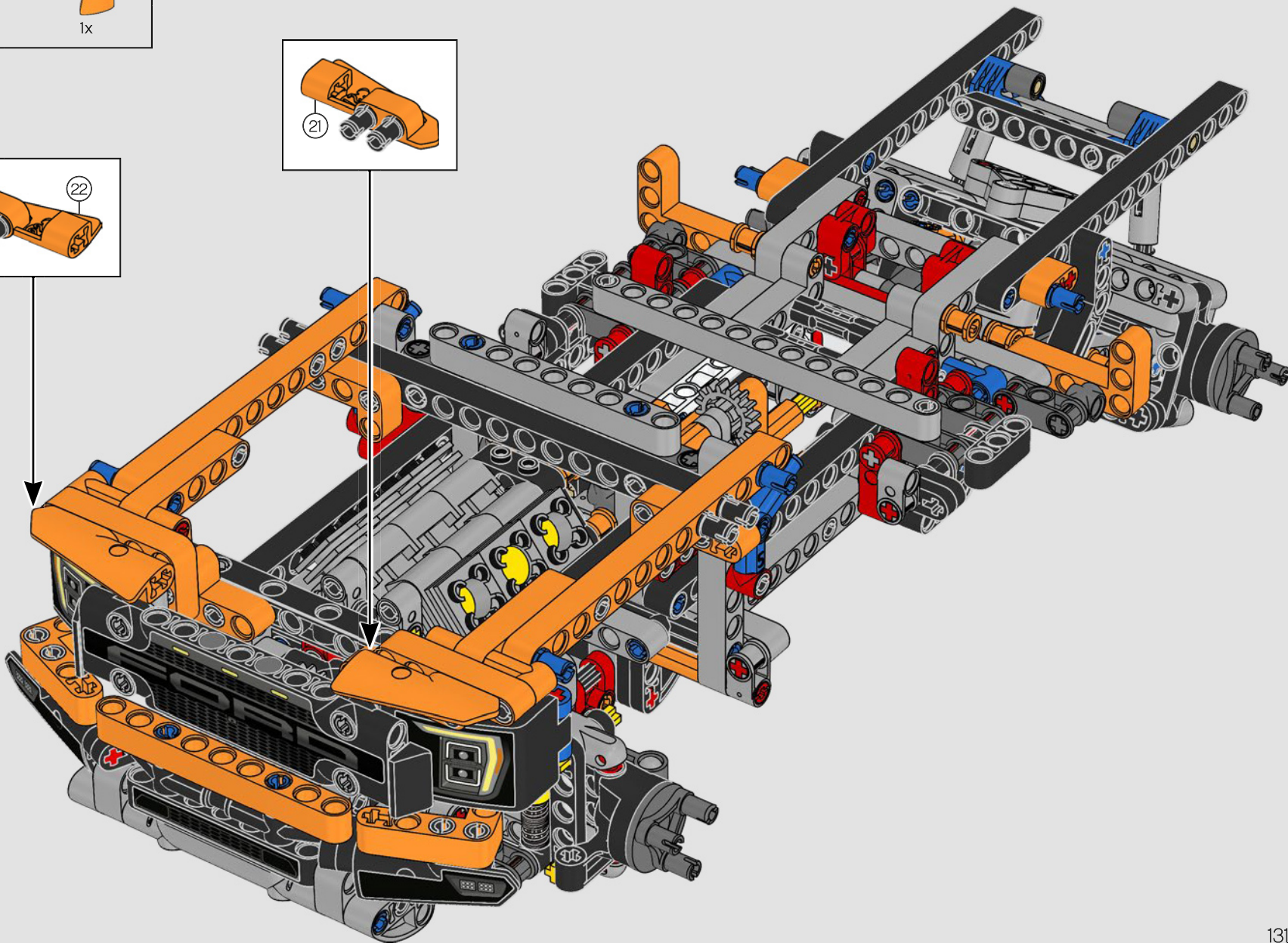
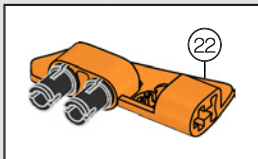
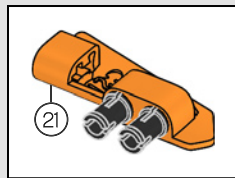

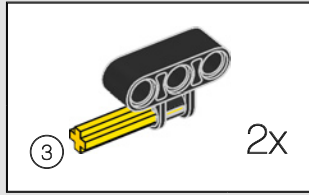
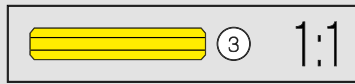
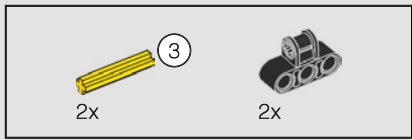

218

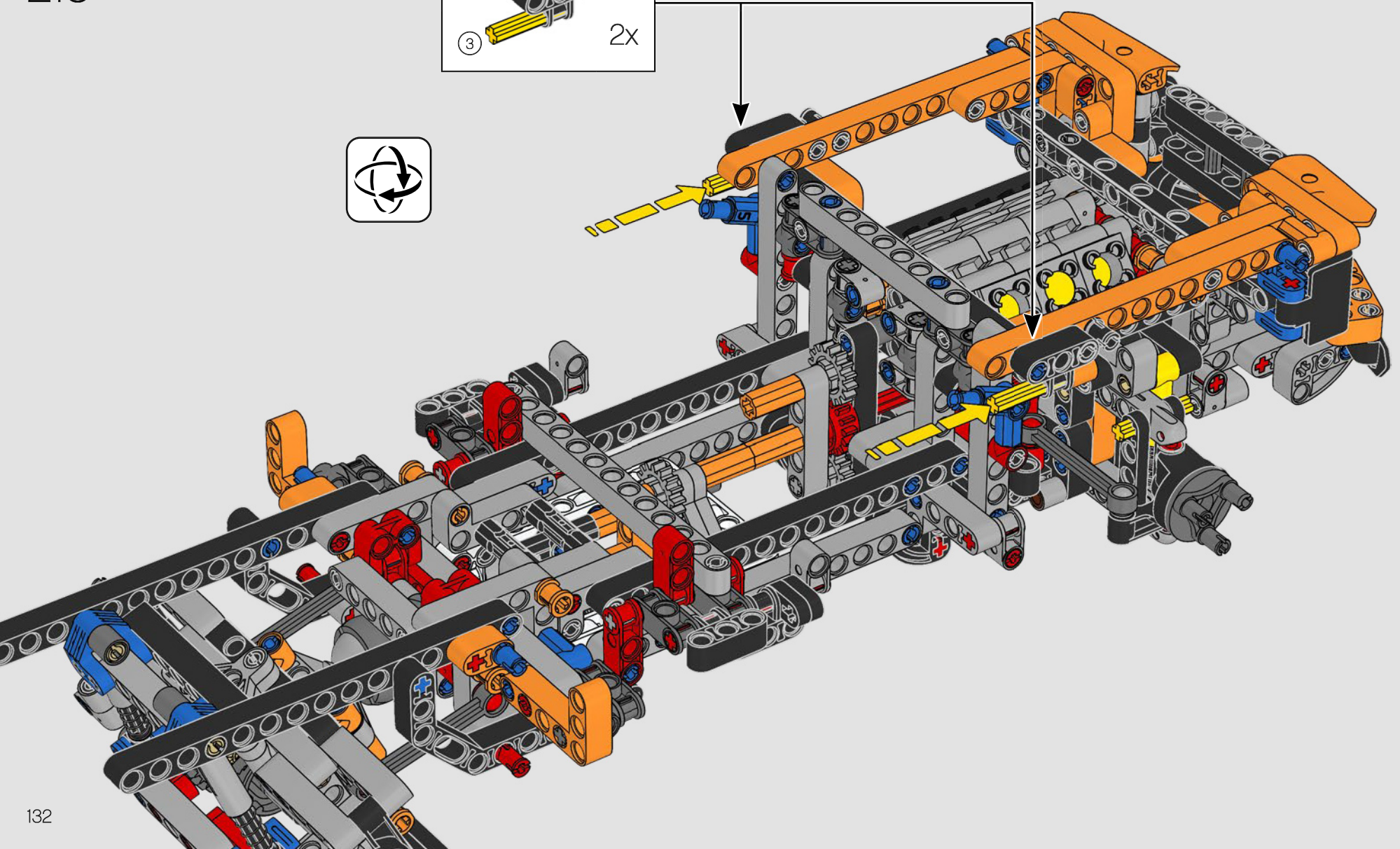

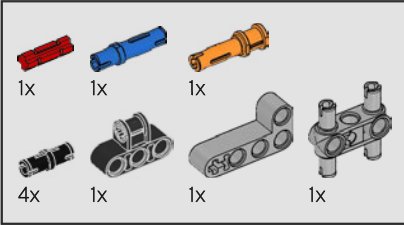
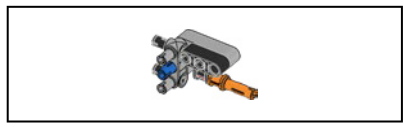

219

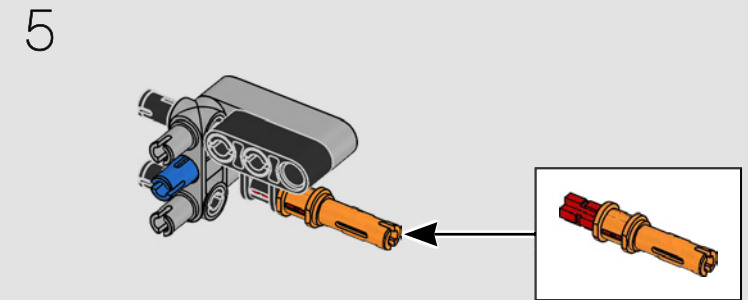
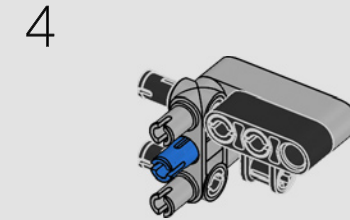
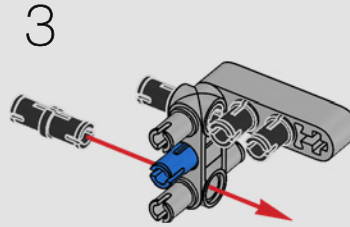
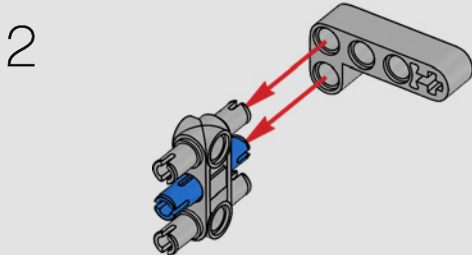
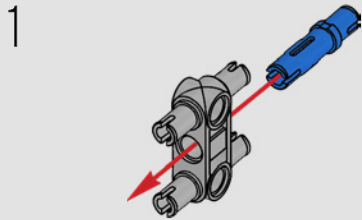

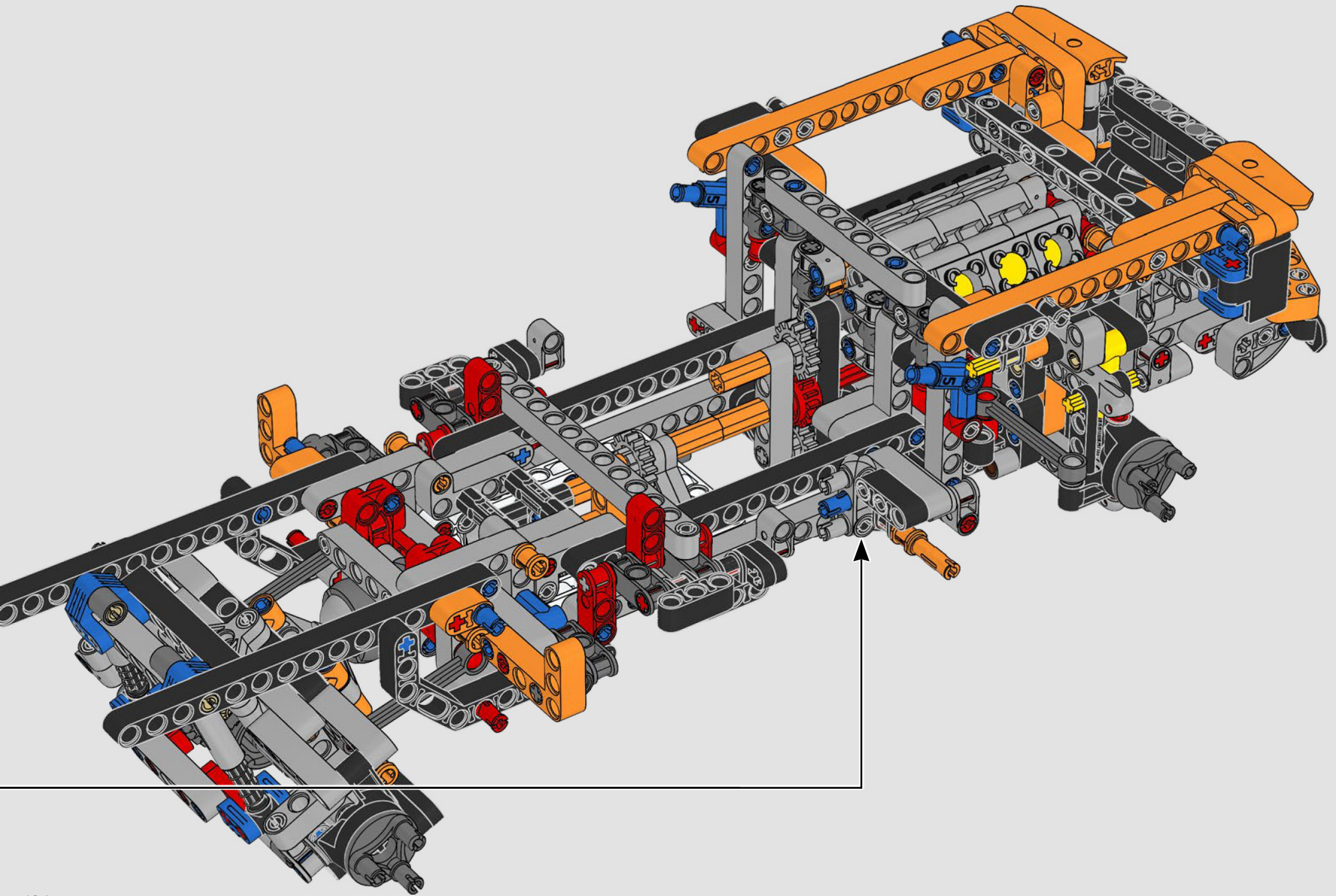

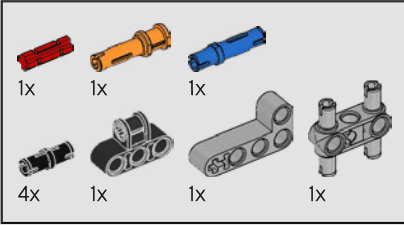
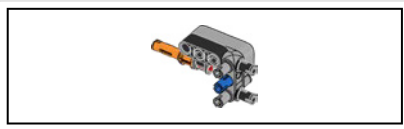

220

1

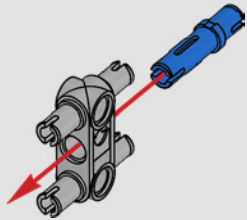

2

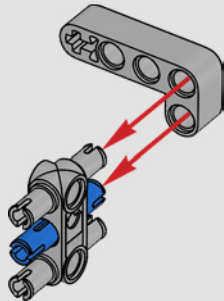

3

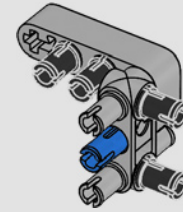

4

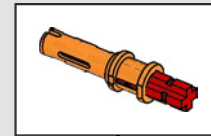
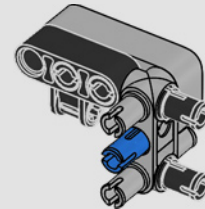

5

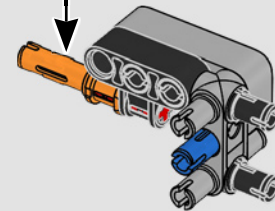

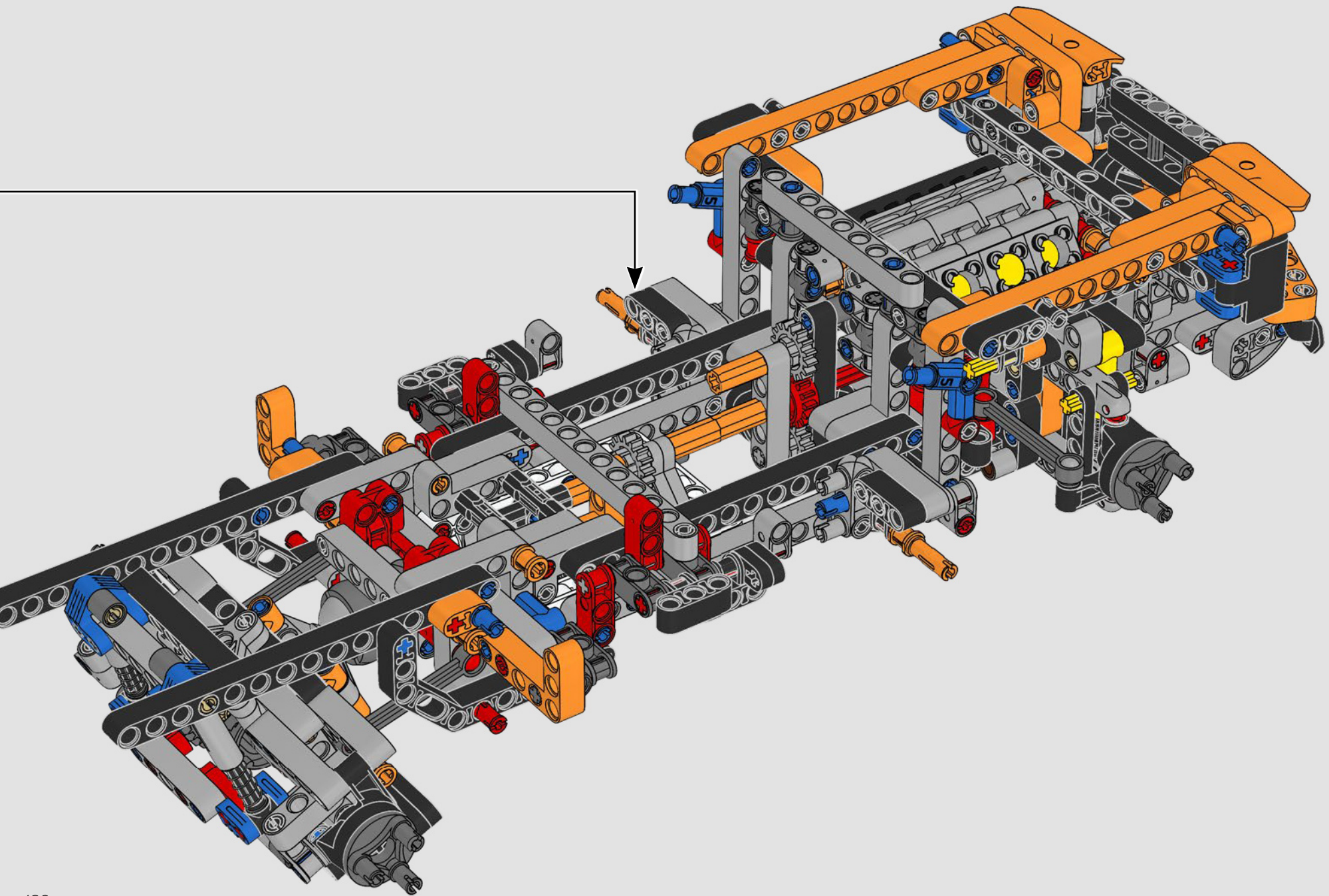

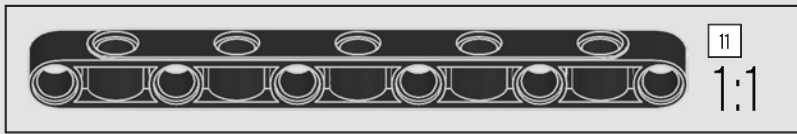
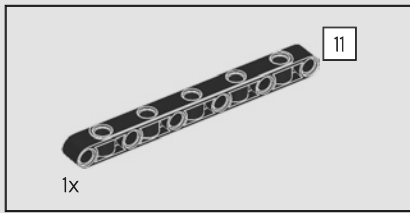

221

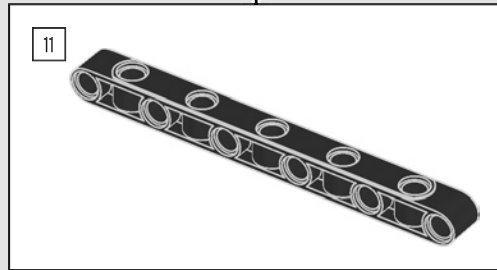
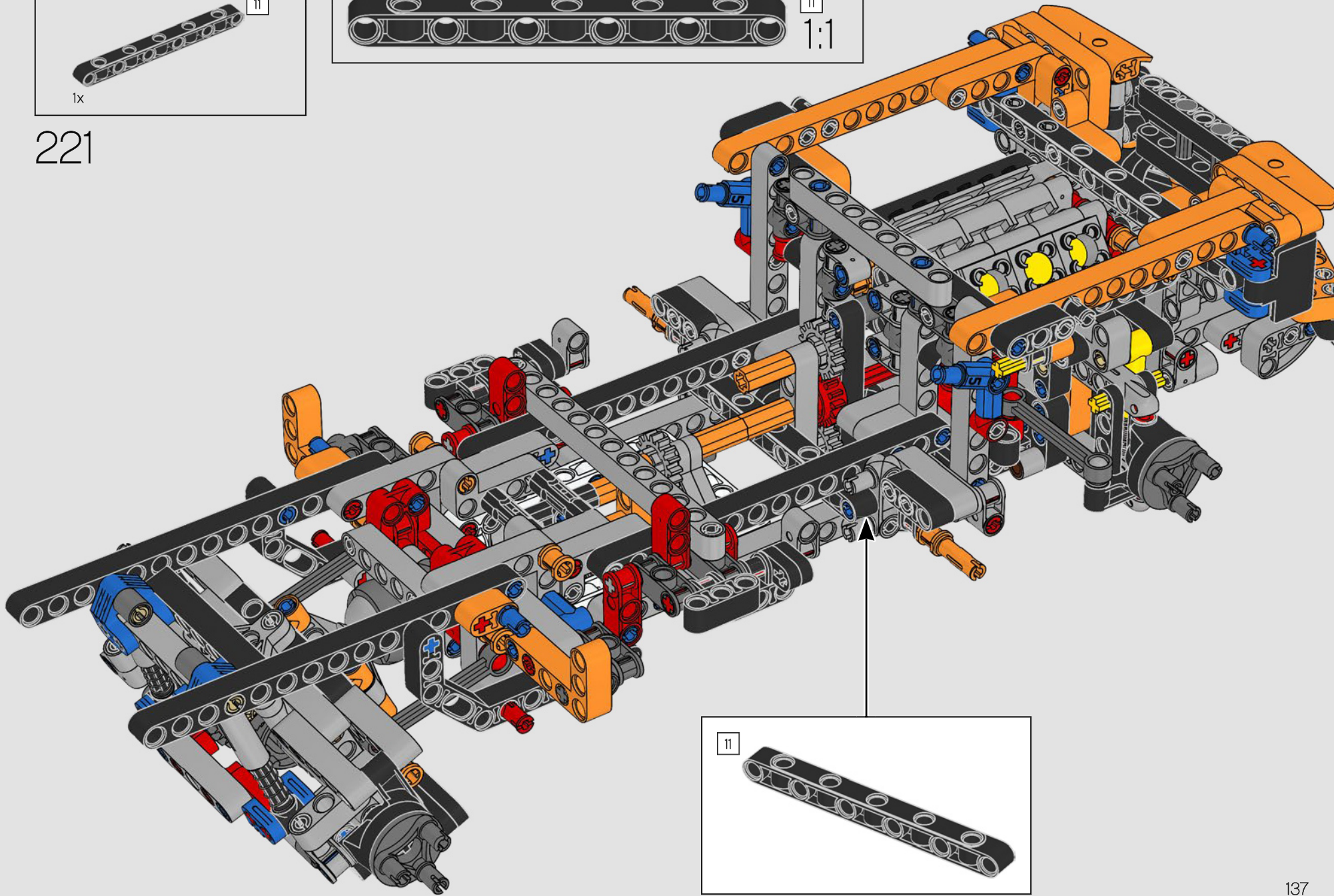

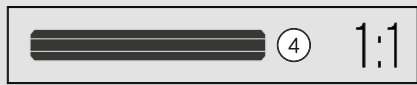
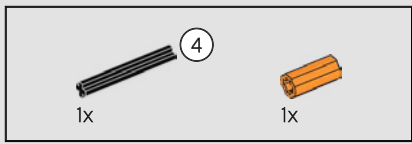

222

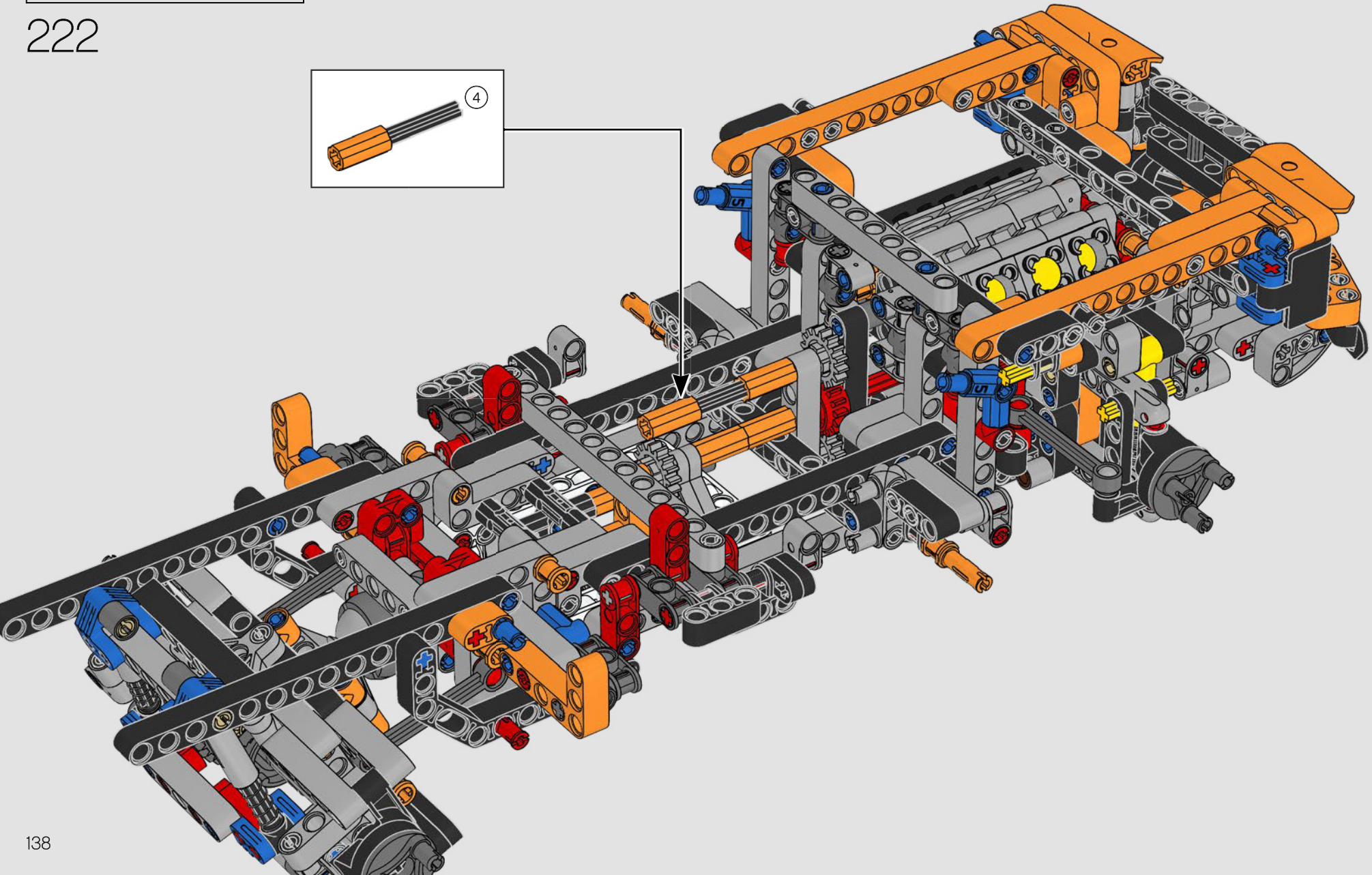
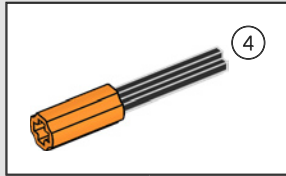

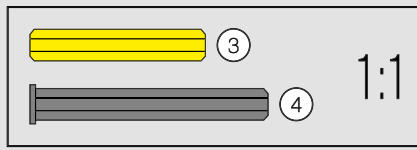
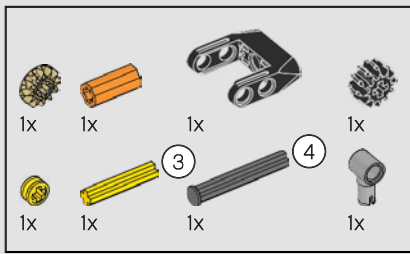

223

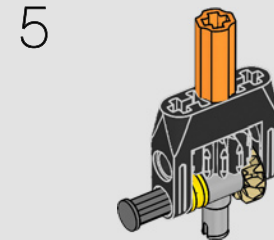
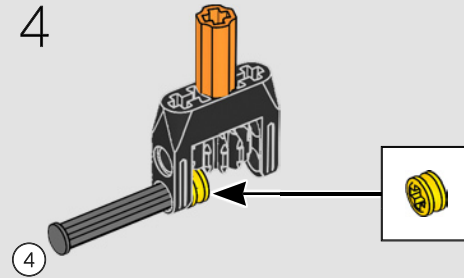
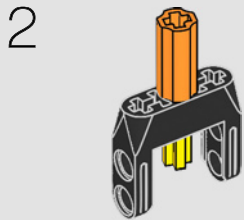
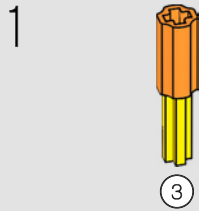

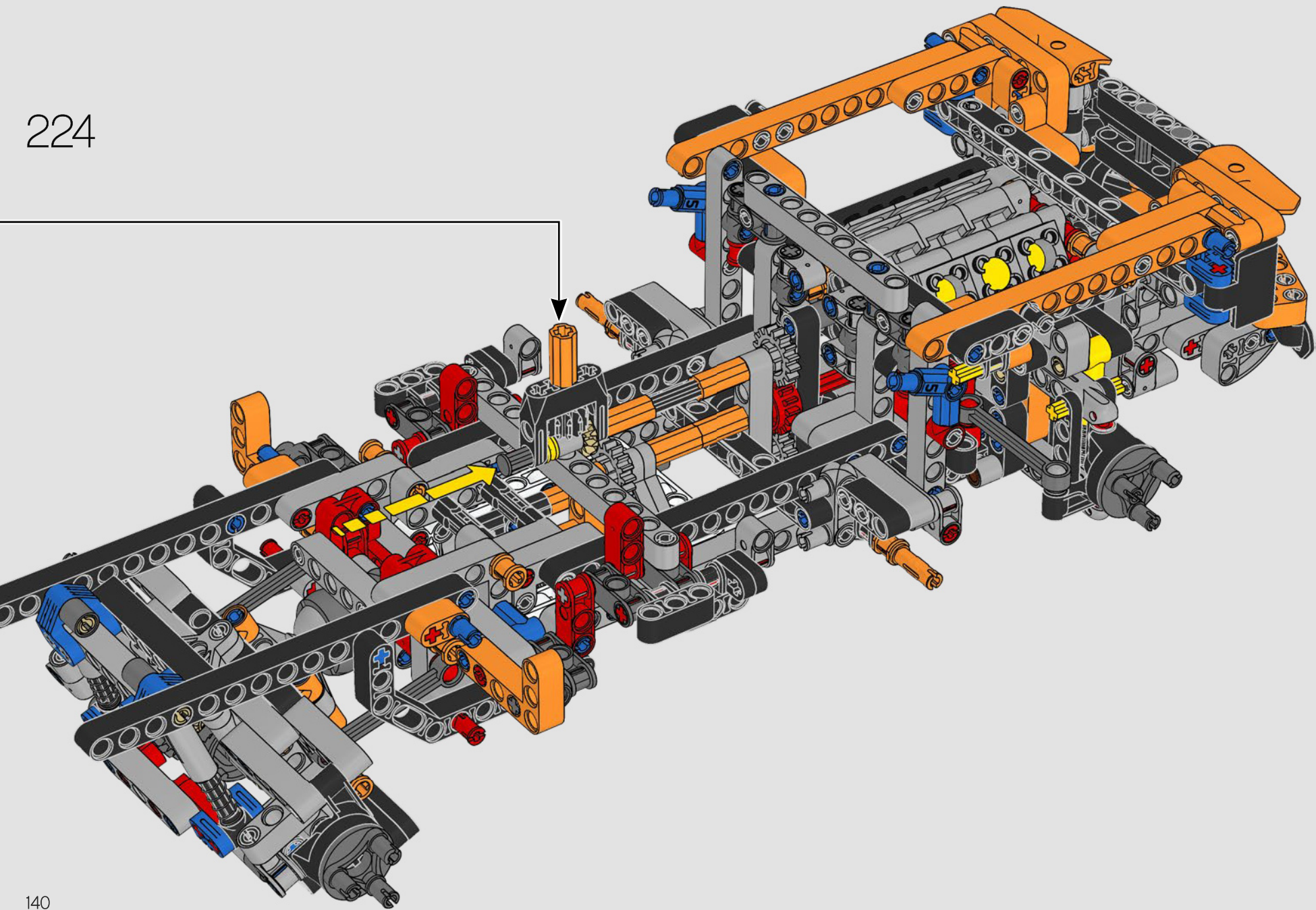

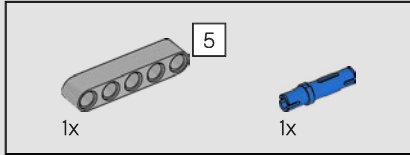
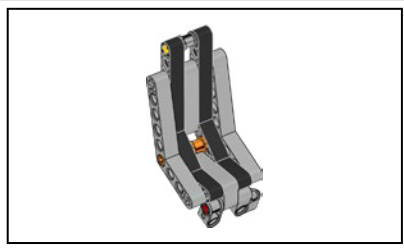

225

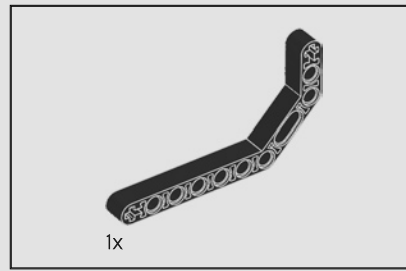
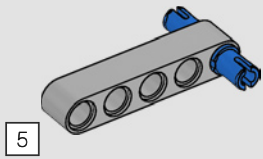

226

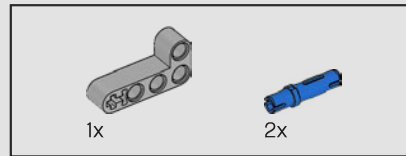
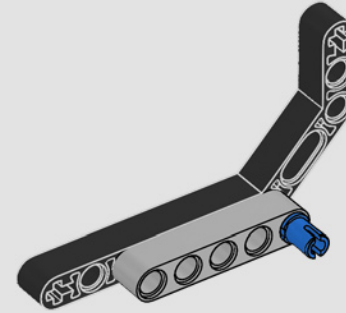

227

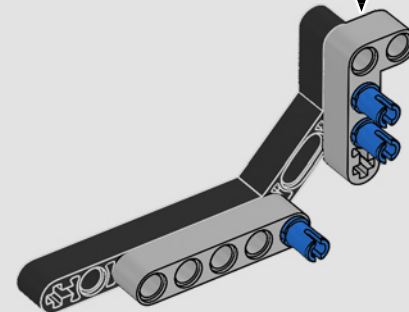
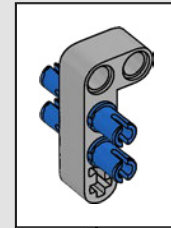

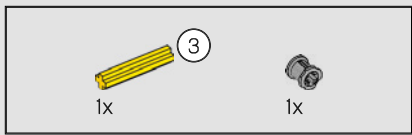

228

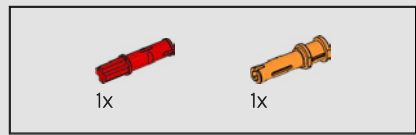
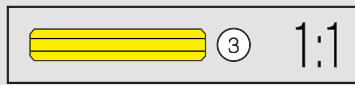
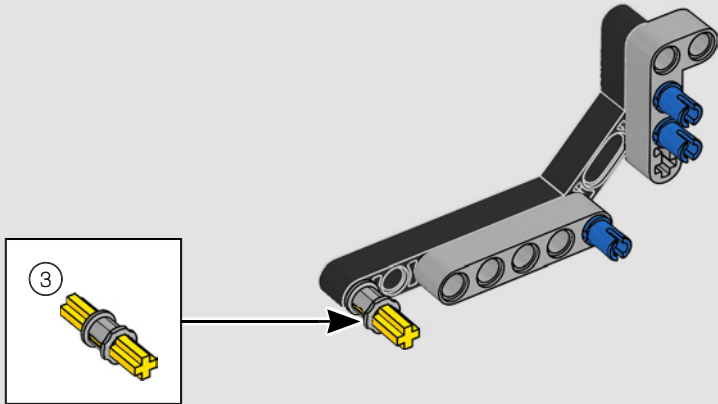

229

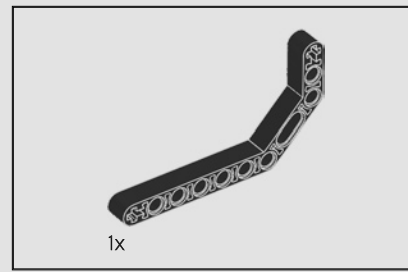
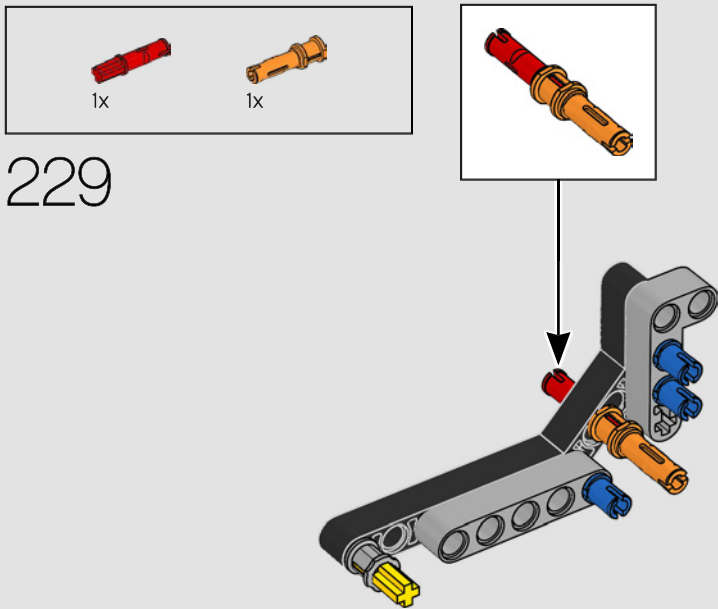

230

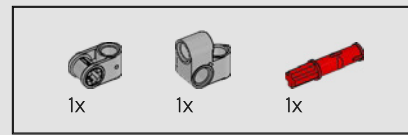
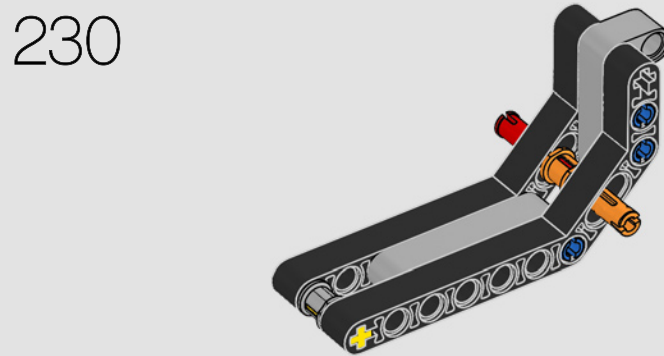

231

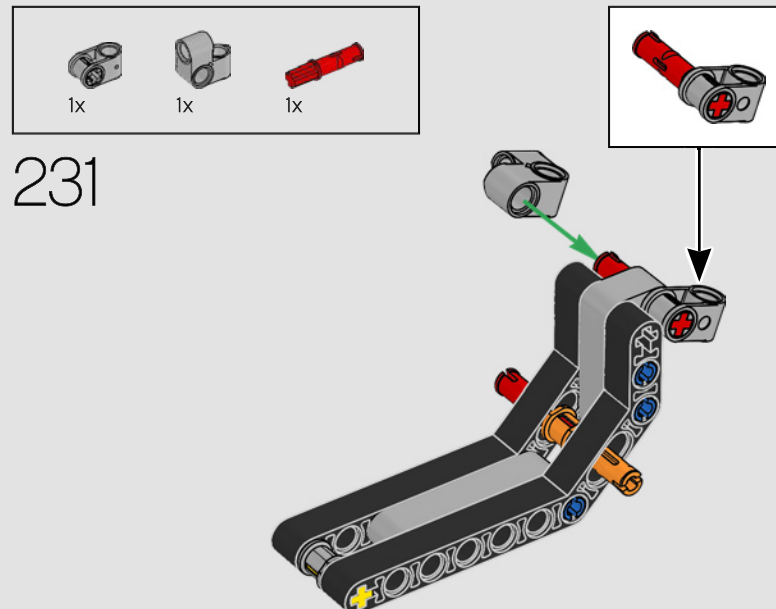

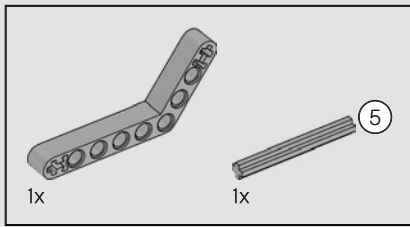

232

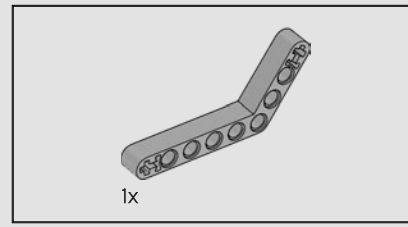
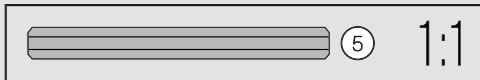
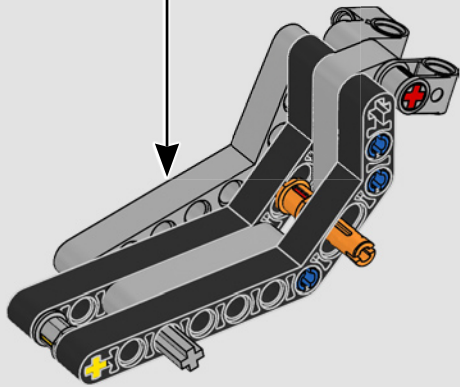
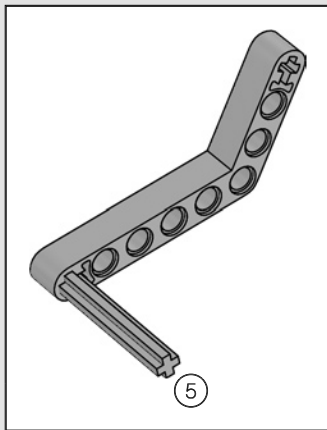

233

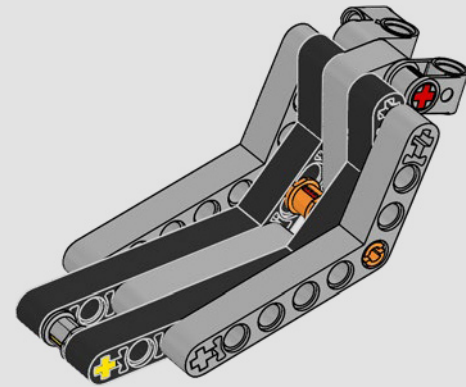

234

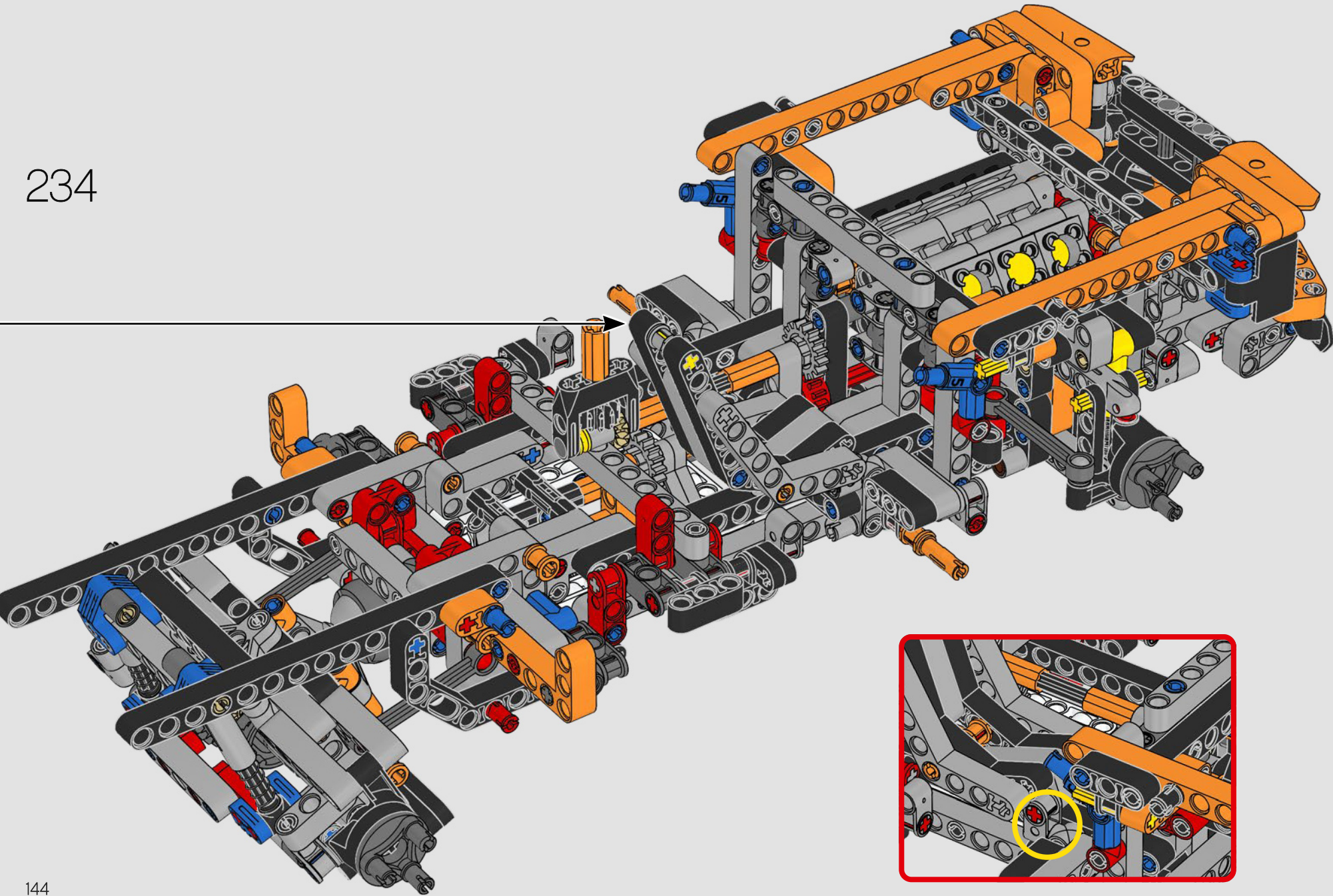

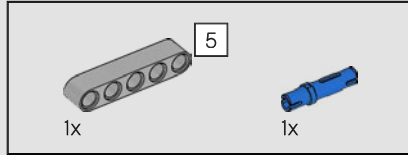
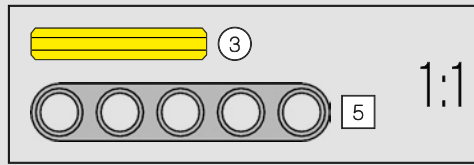
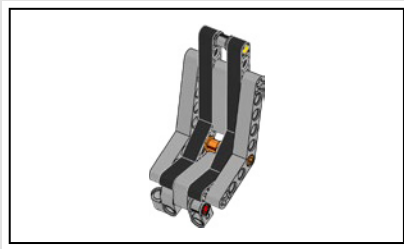

235

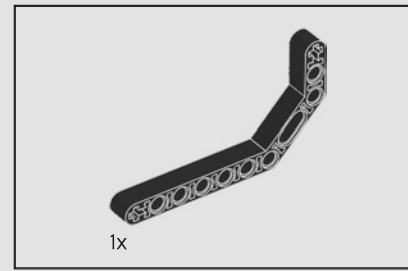
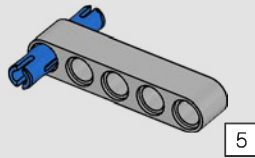

236

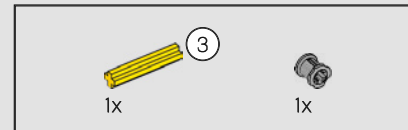
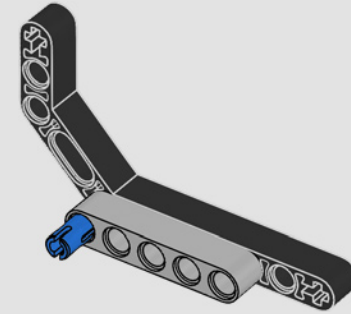

237

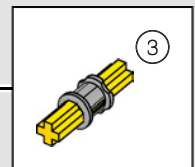
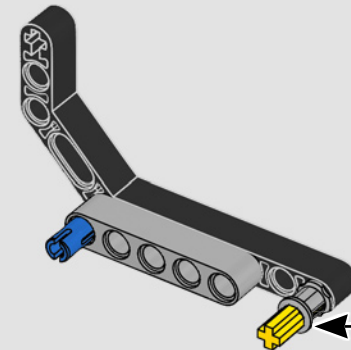

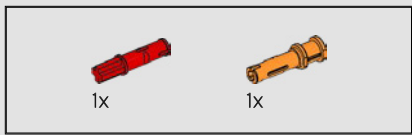

238

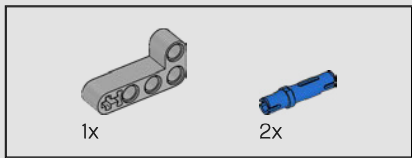
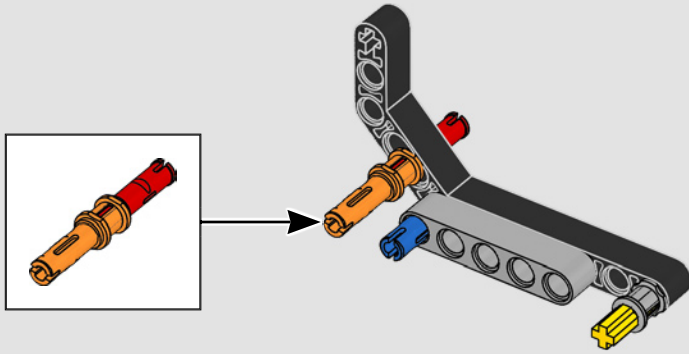

239

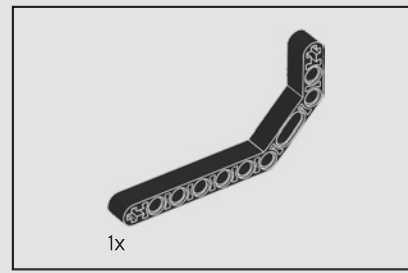
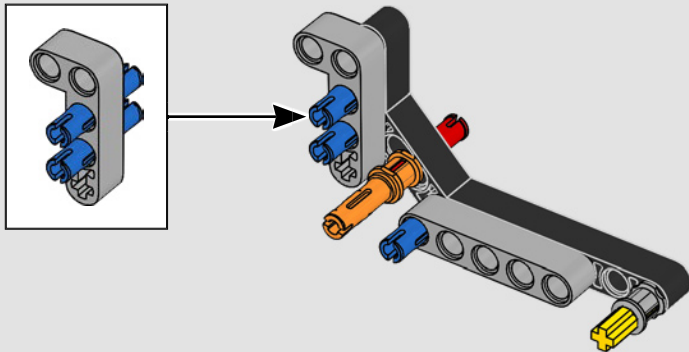

240

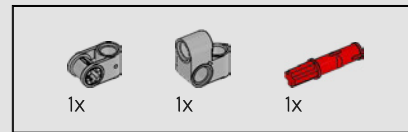
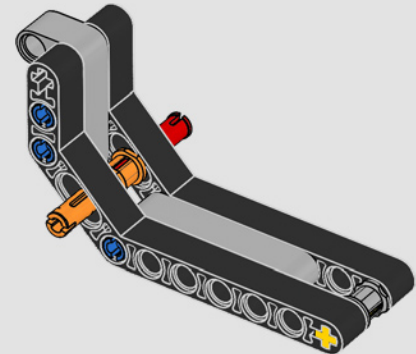

241

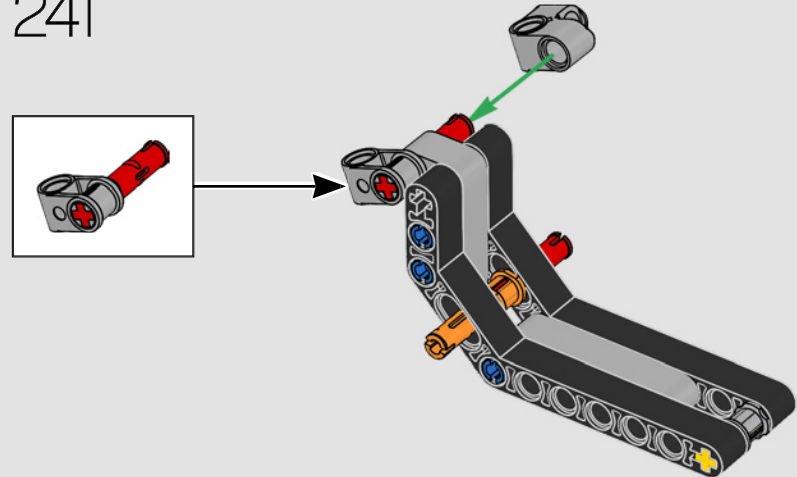

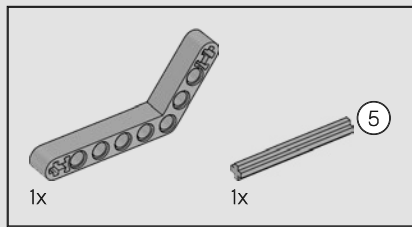

242

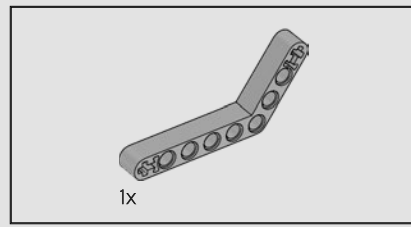
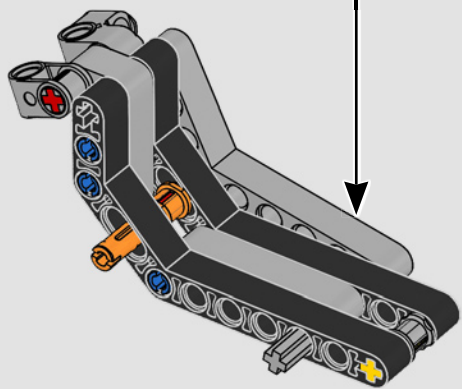
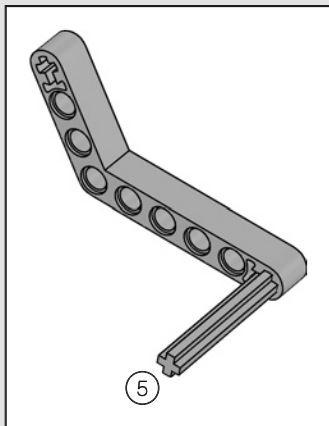
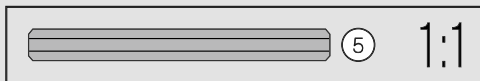

243

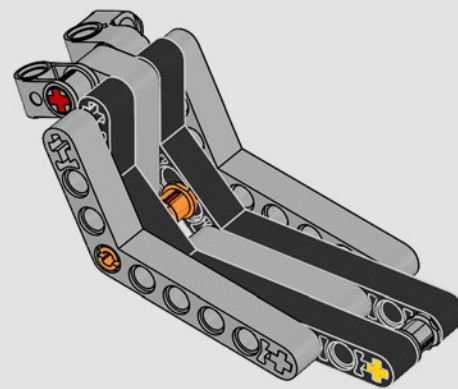

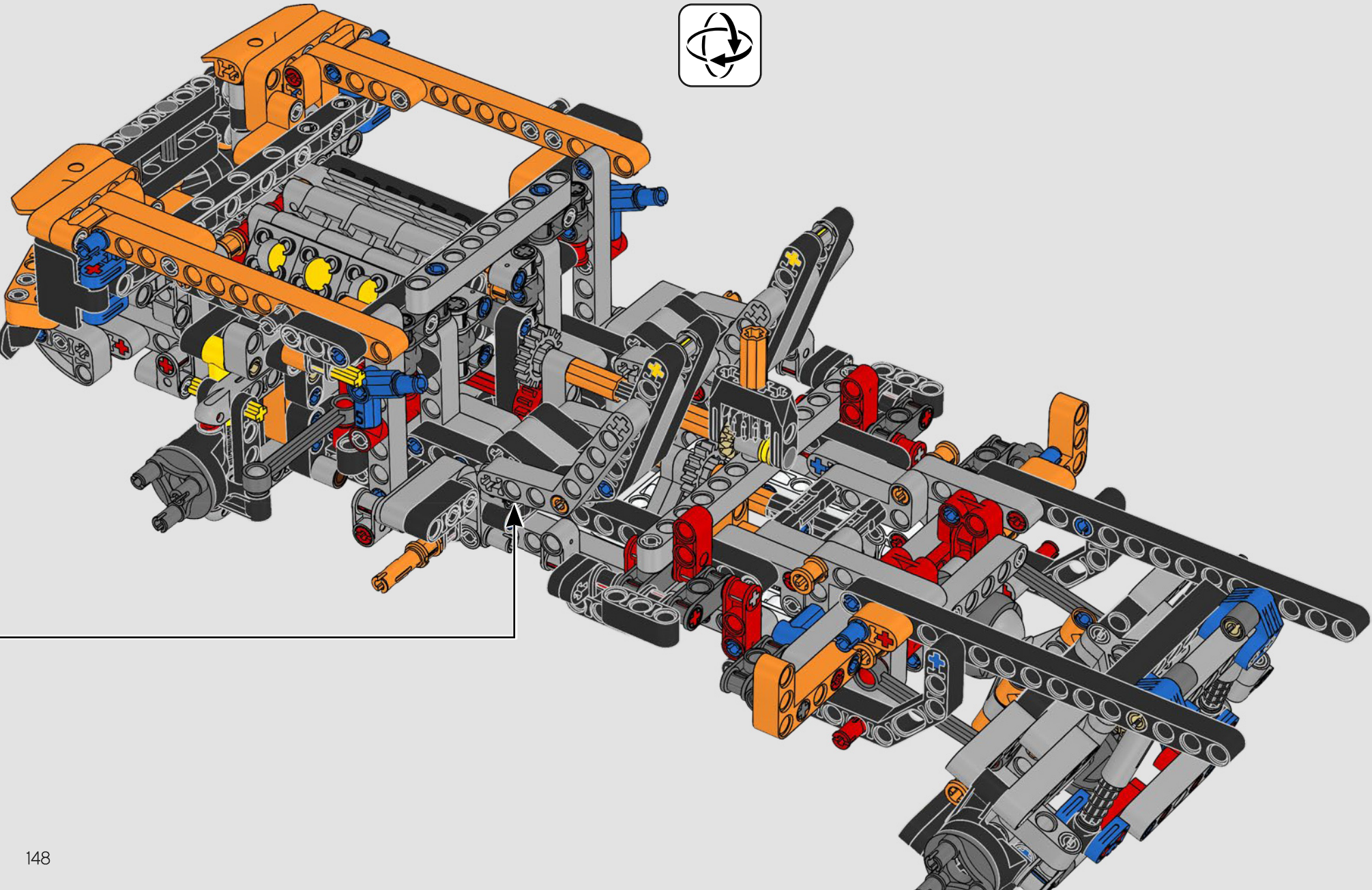
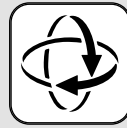

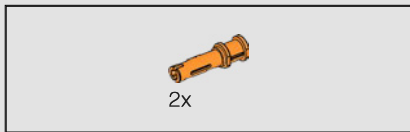

245

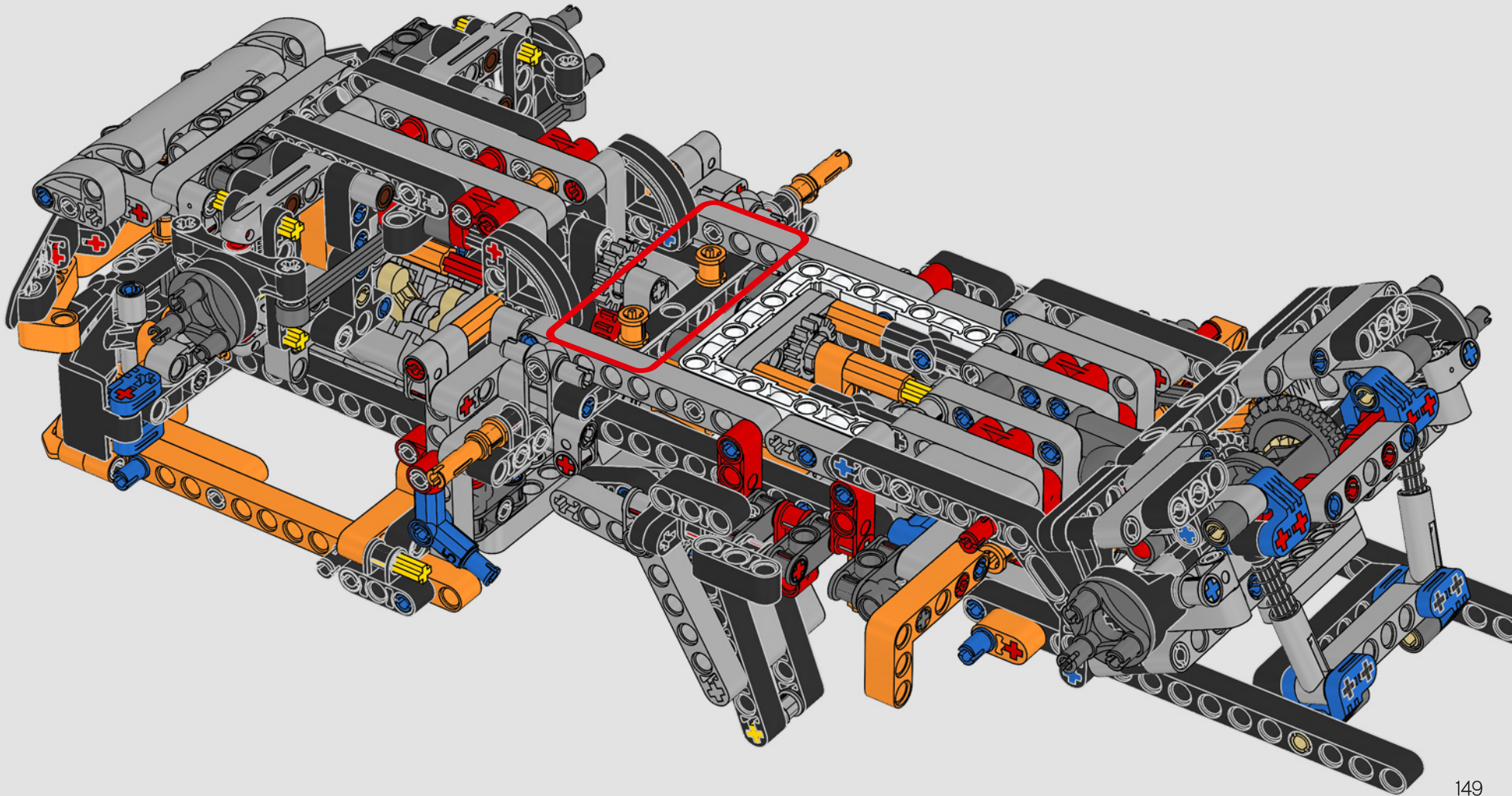

The fully redesigned 2021 F-150 Raptor boosts its capability with all-new, five-link rear suspension to better maintain axle position on rough terrain.

La F-150 Raptor 2021 entièrement redessinée renforce sa capacité grâce à une toute nouvelle suspension arrière à cinq bras qui permet de mieux maintenir la position de l'essieu sur les terrains accidentés.

La F-150 Raptor de 2021, de diseño radicalmente nuevo, mejora su desempeño con una suspensión trasera de cinco brazos totalmente renovada que mantiene mejor la posición del eje en terrenos difíciles.

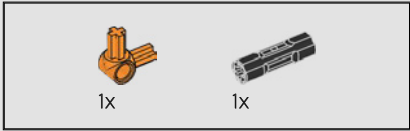
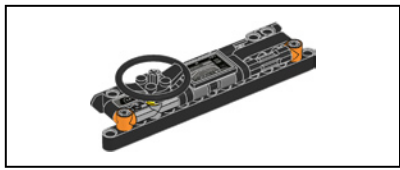

246

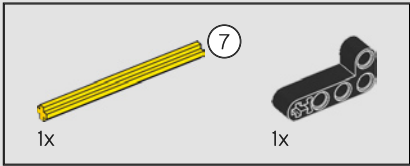
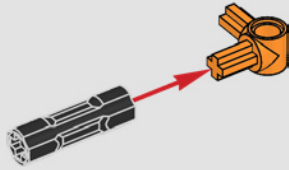

247

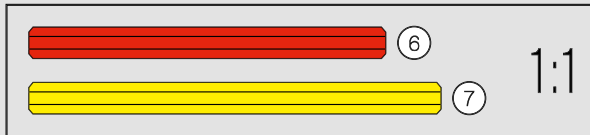
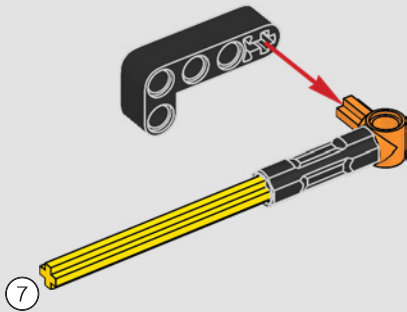

248

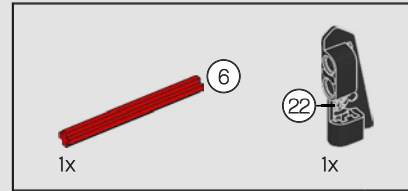
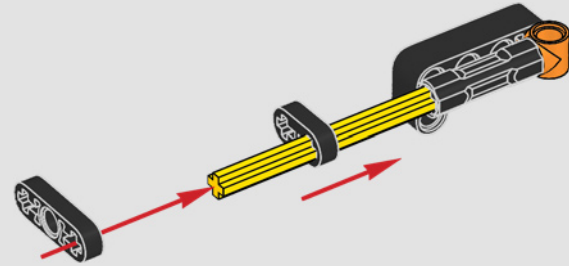

249

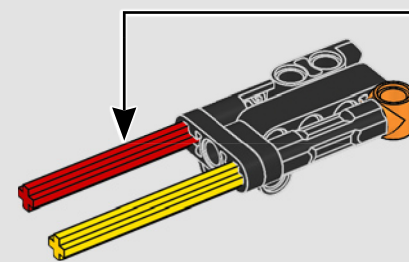
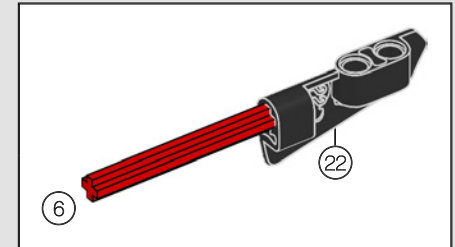

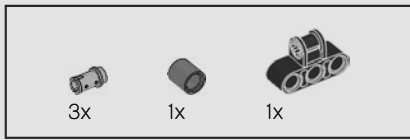

250

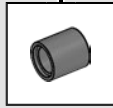
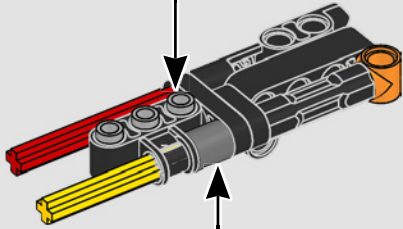
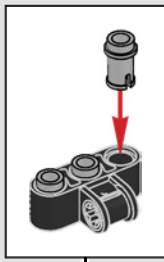

251

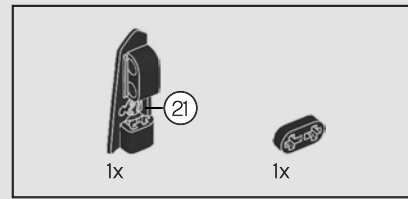
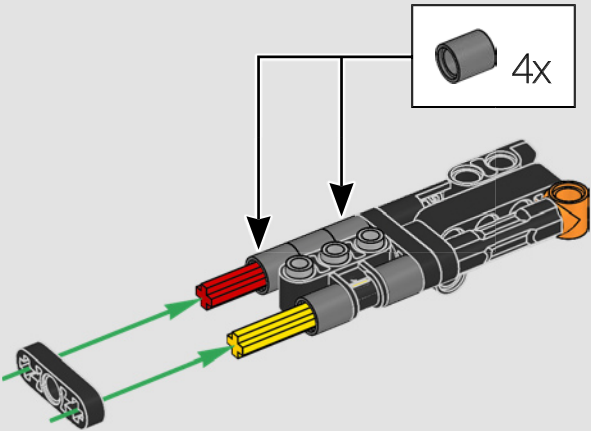

252

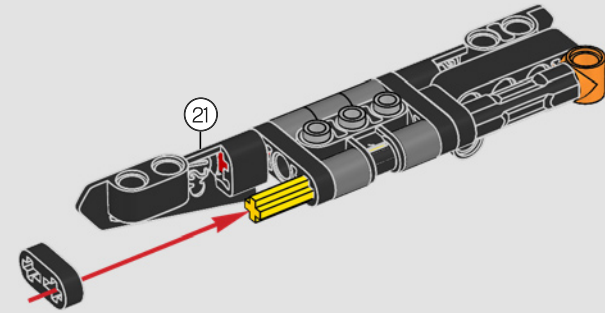

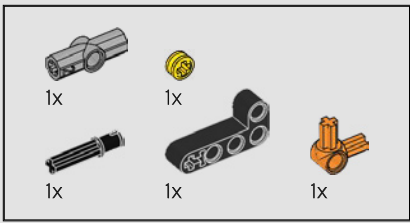

253

1

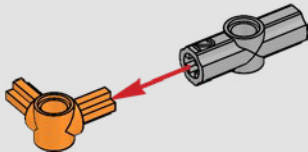

2

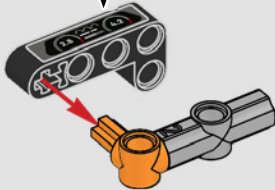
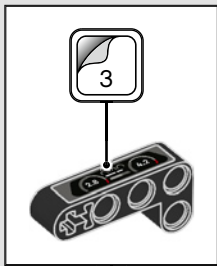

3

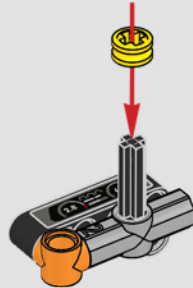

254

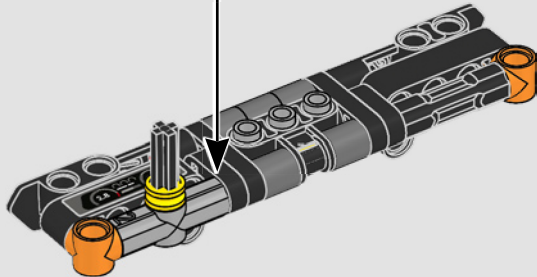

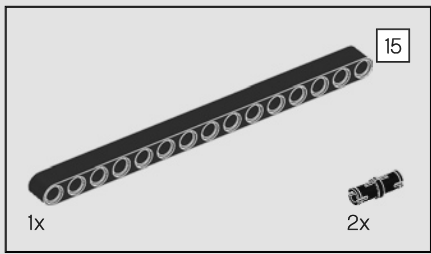

255

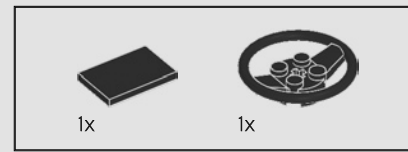
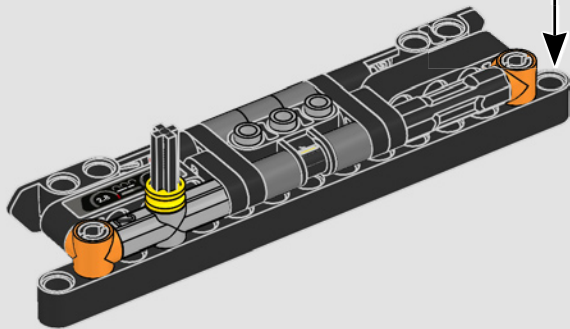
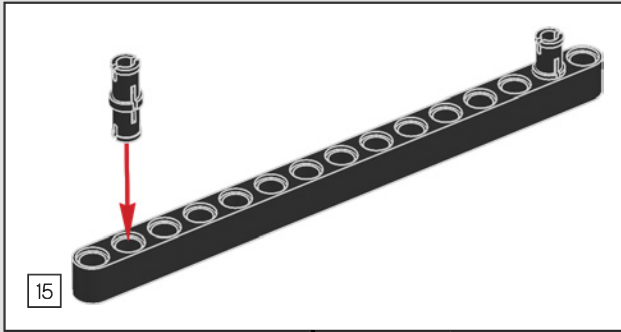

256

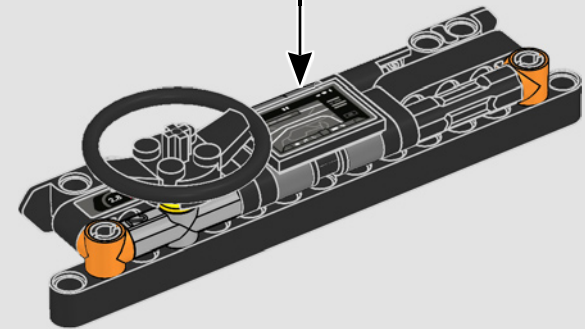
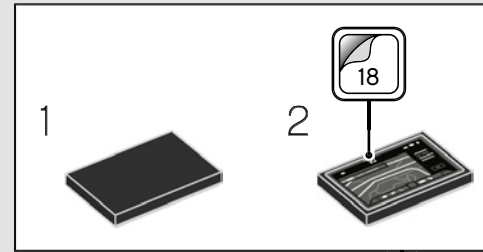

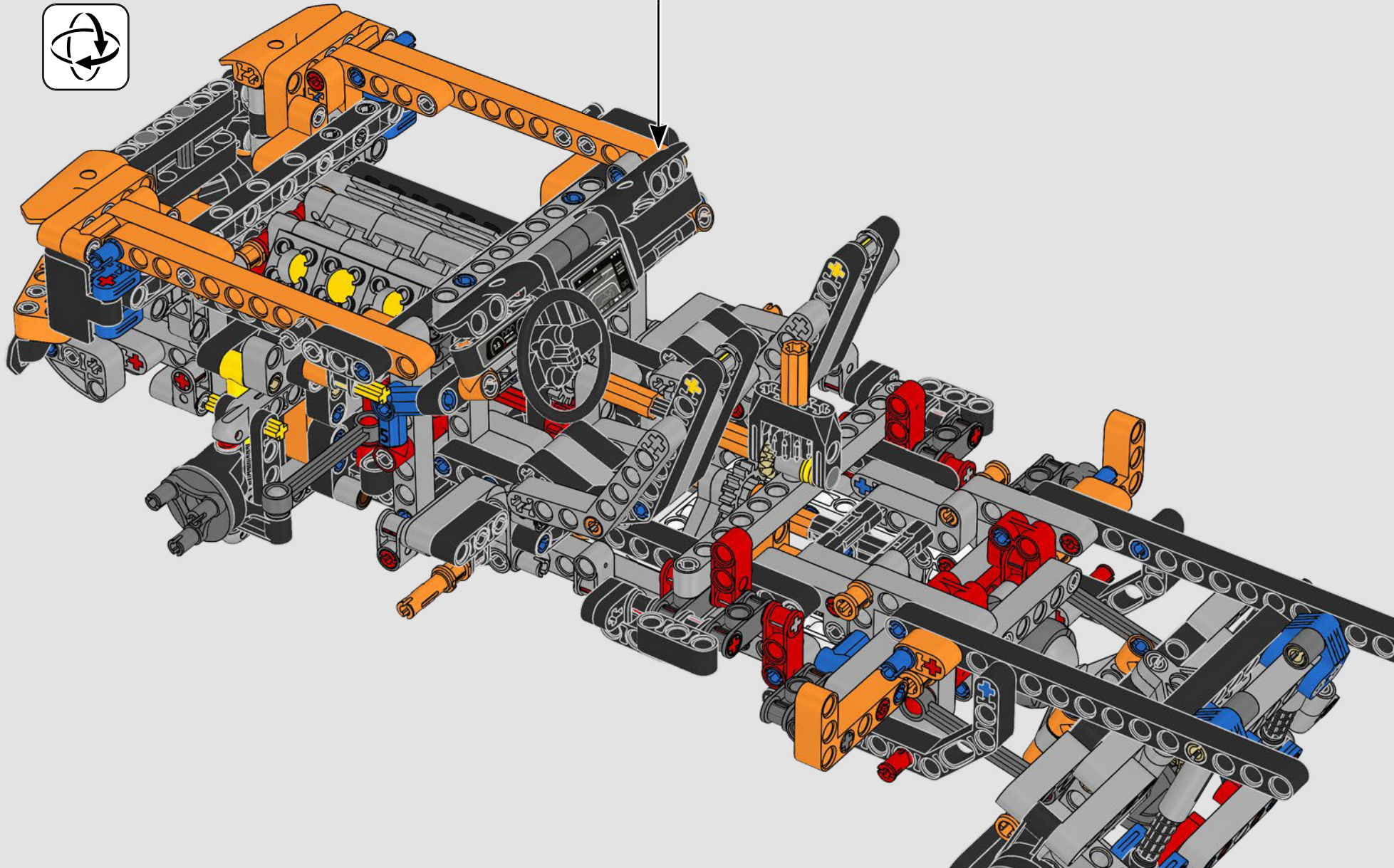

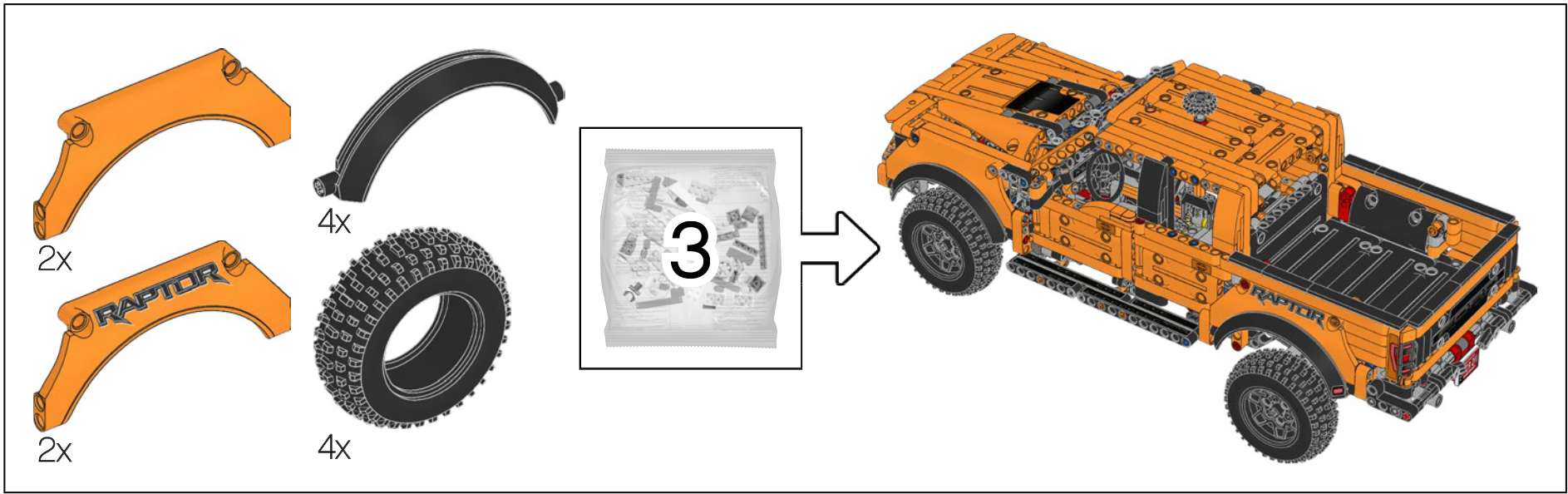



2x

258

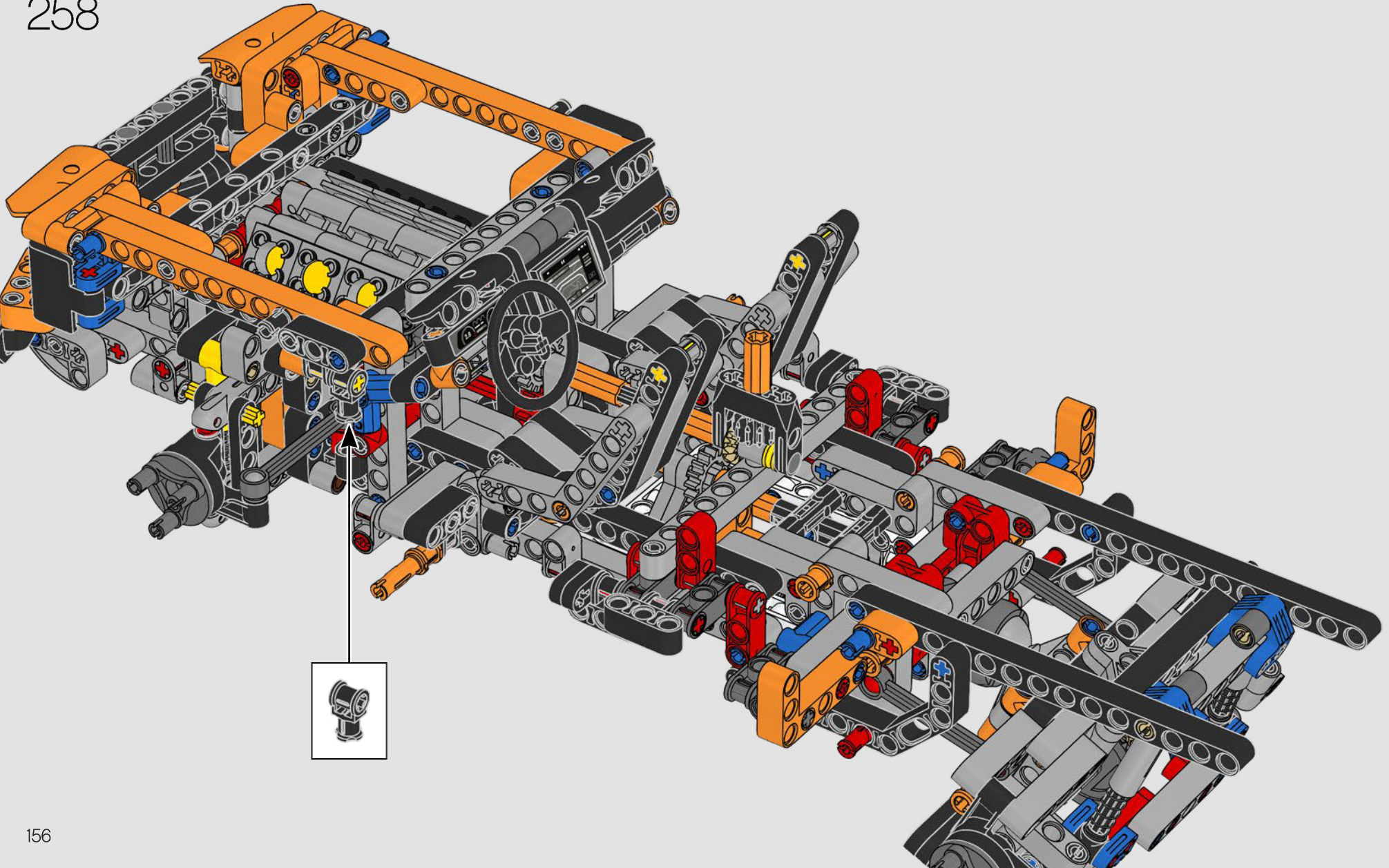

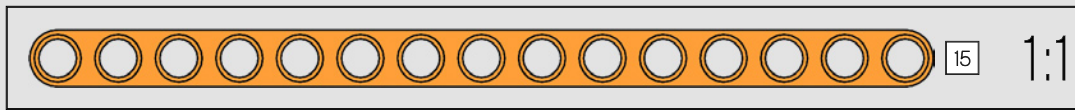
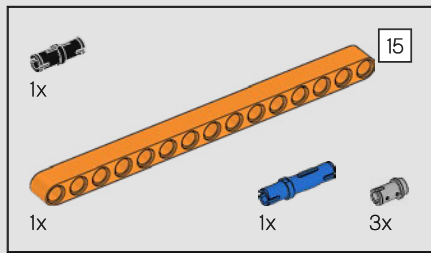

259

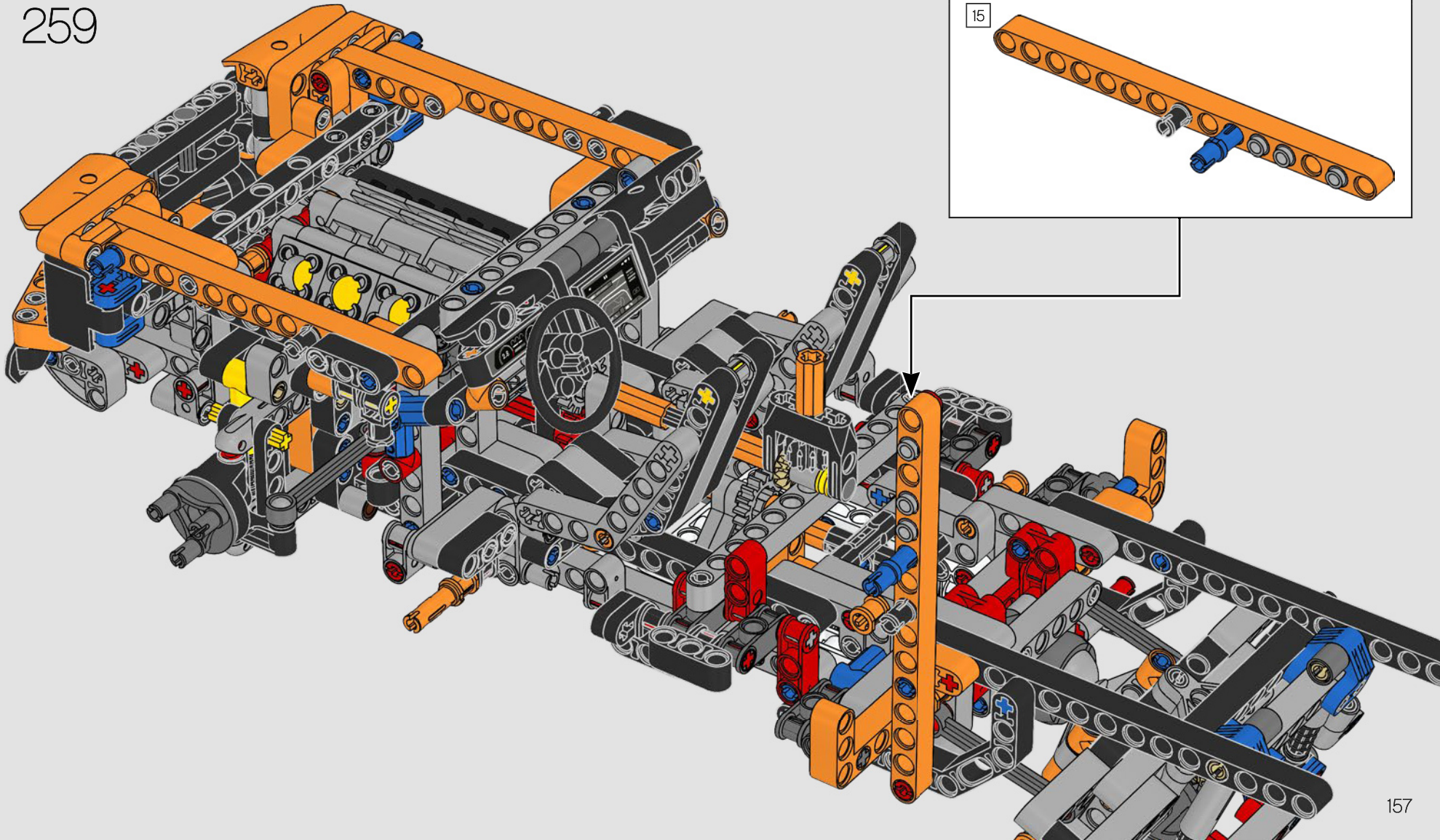
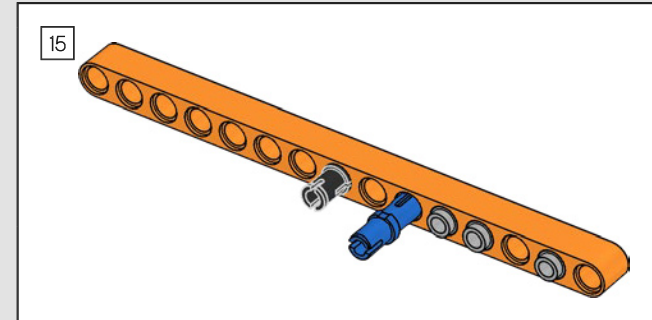

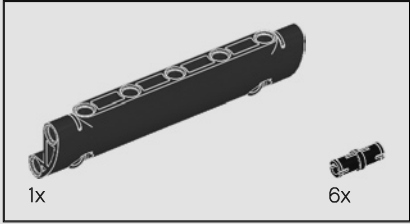
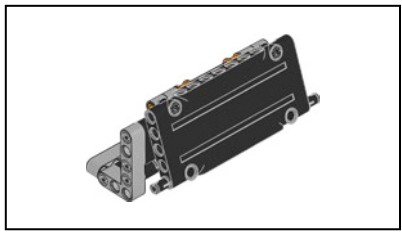

260

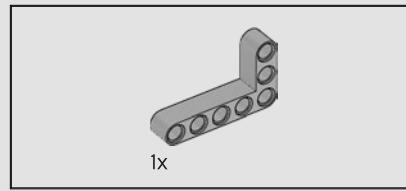
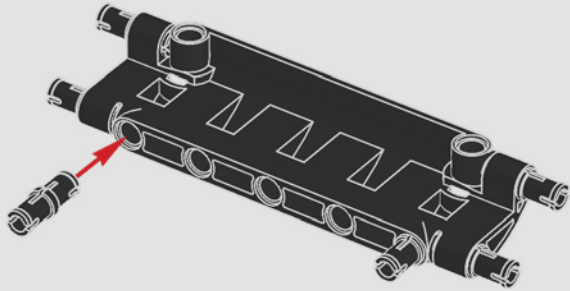

261

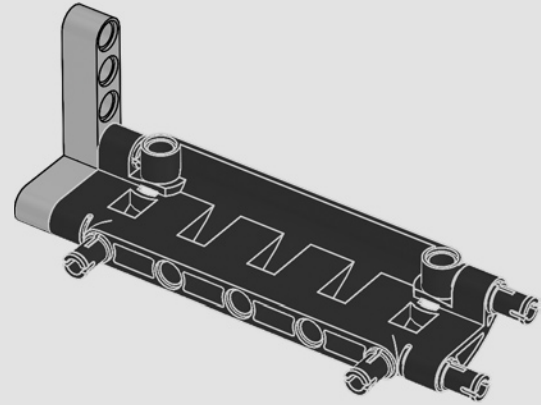

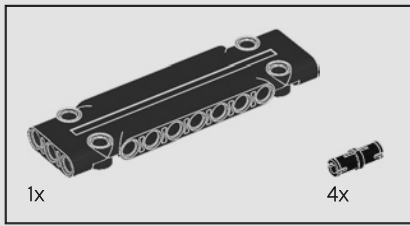

262

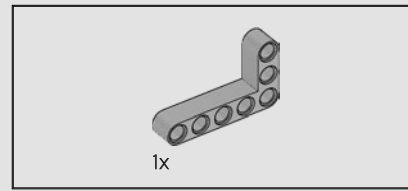
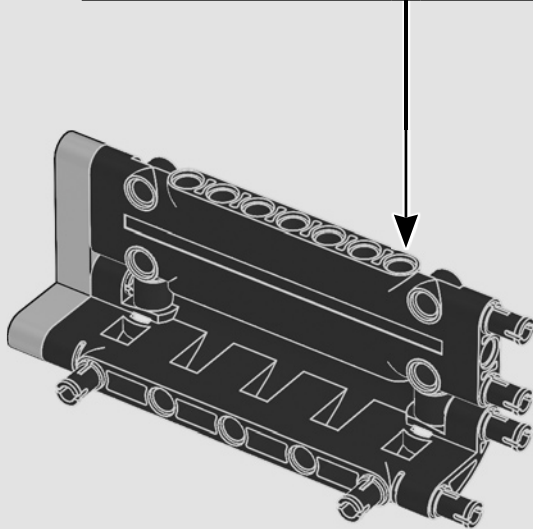
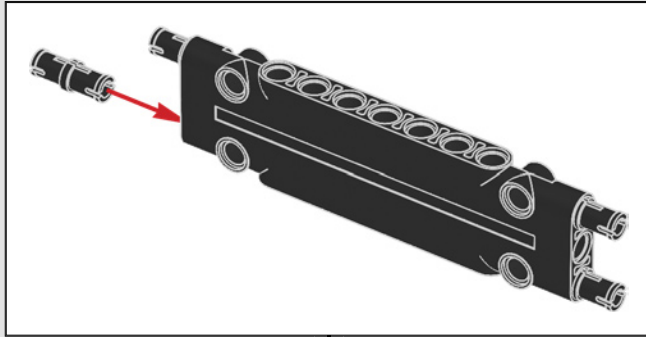

263

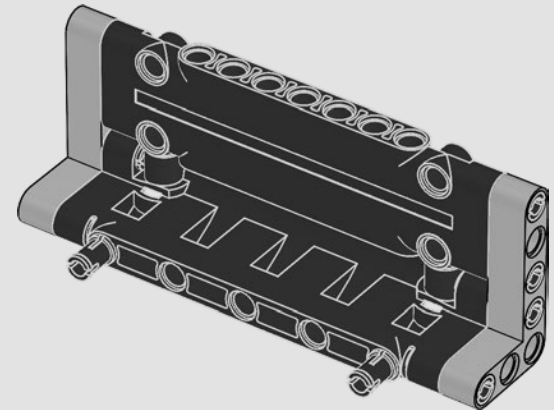

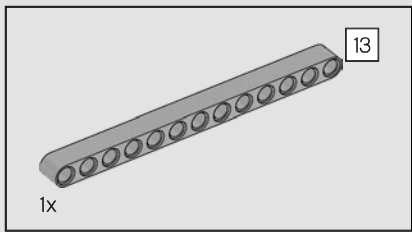

264

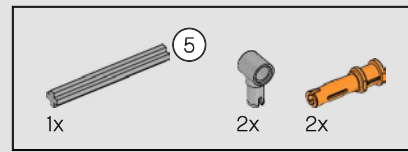
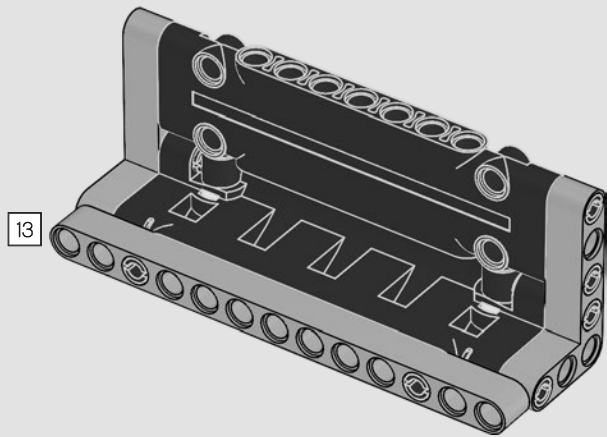

265

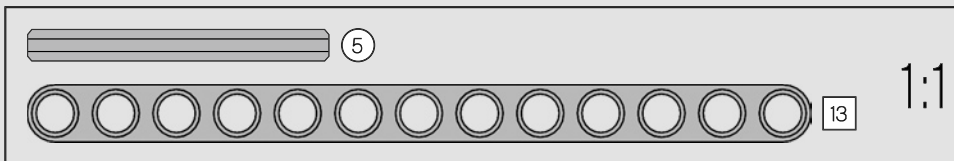
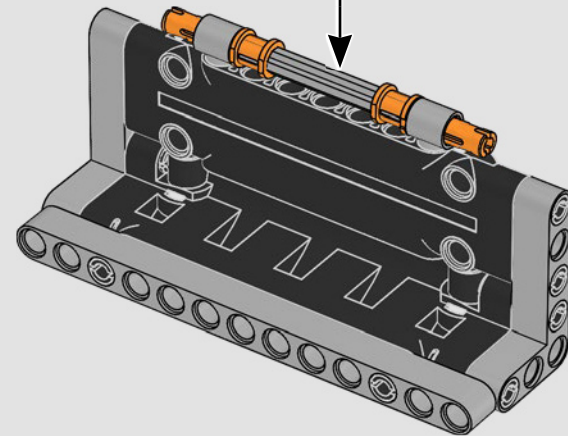
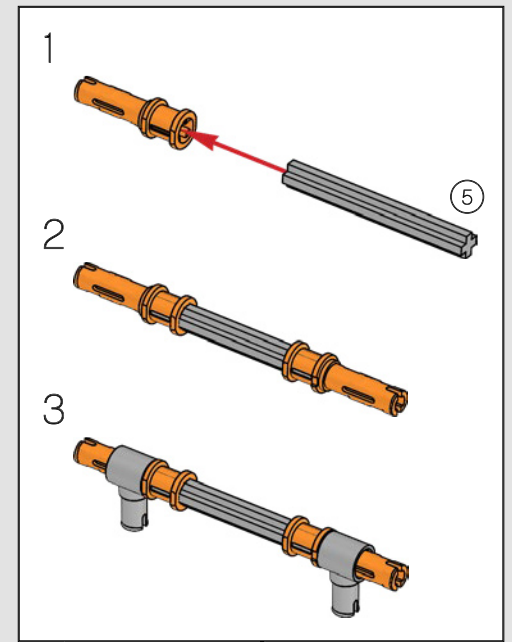



266

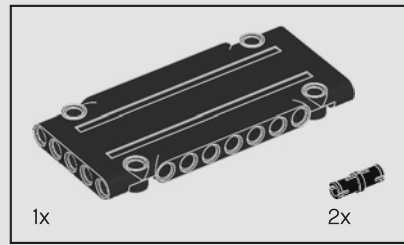
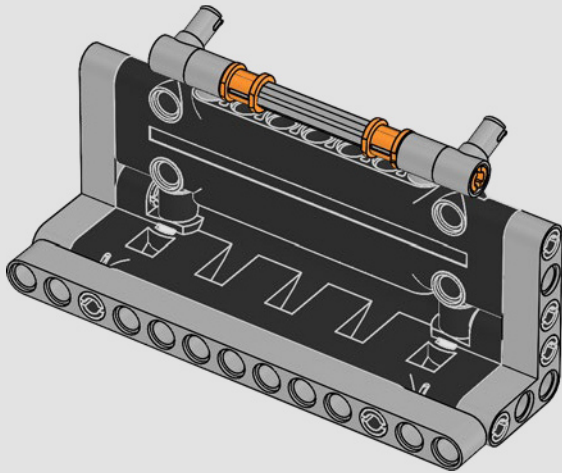

267

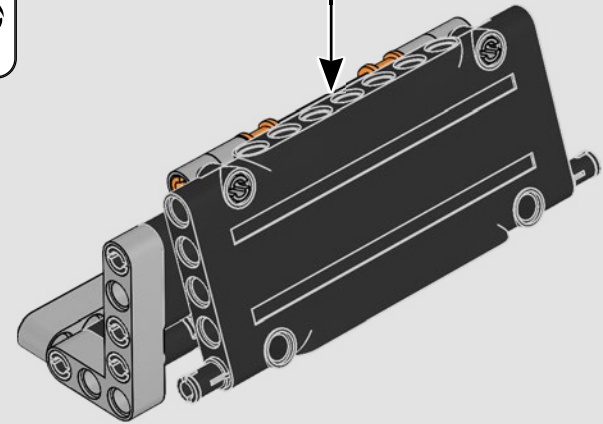
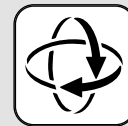
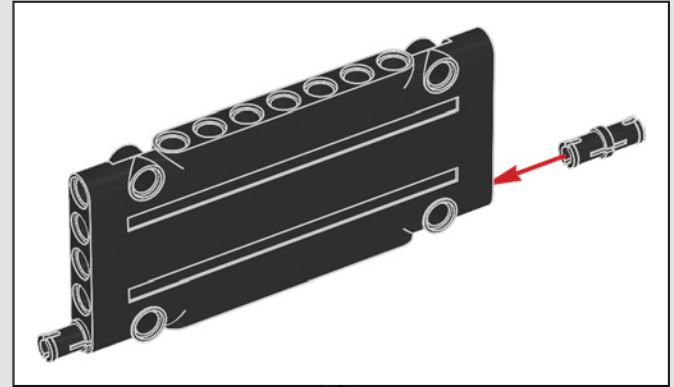

268

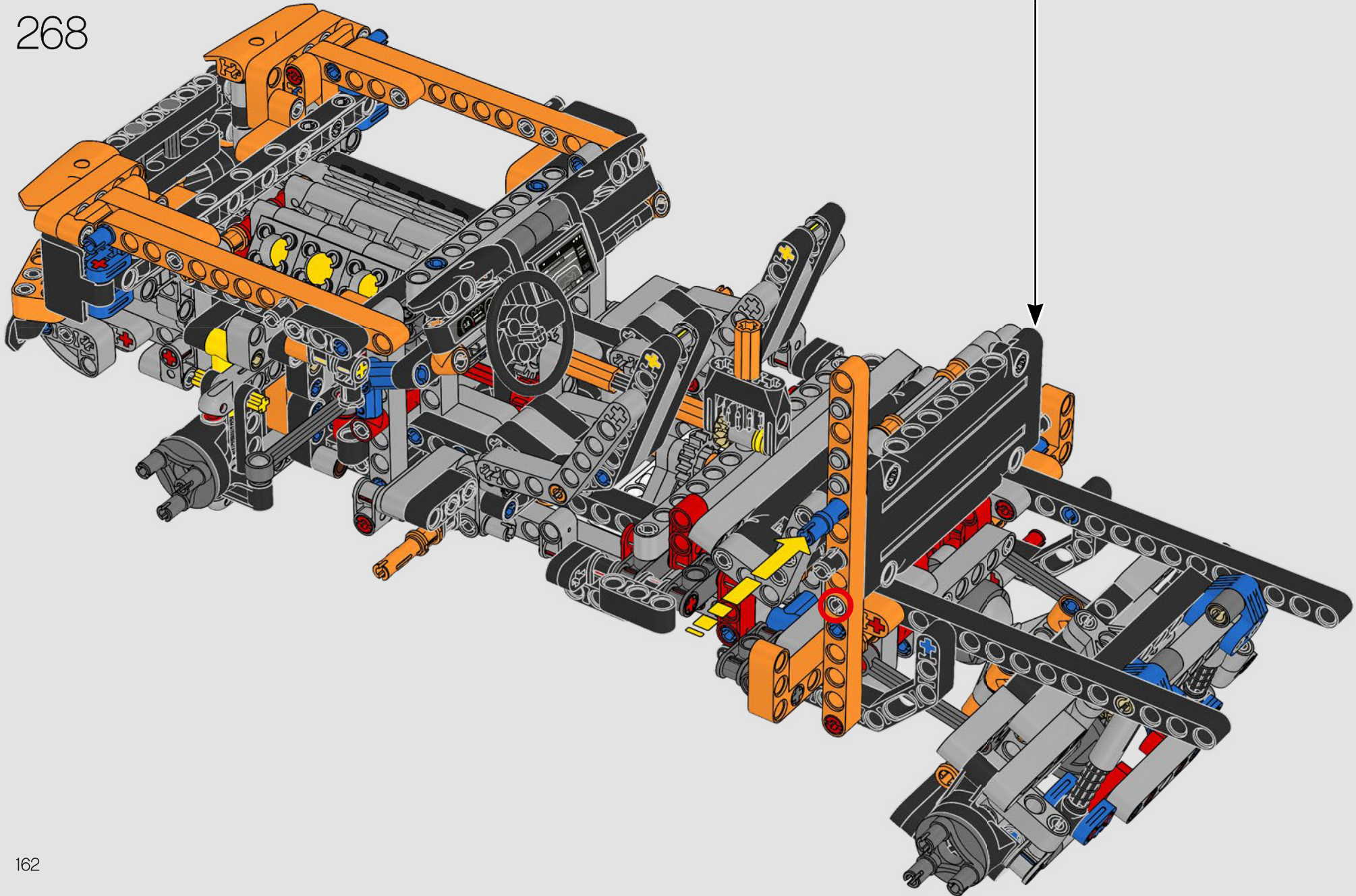

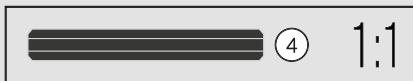
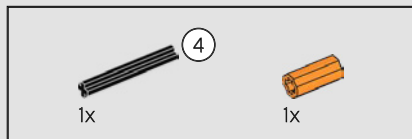

269

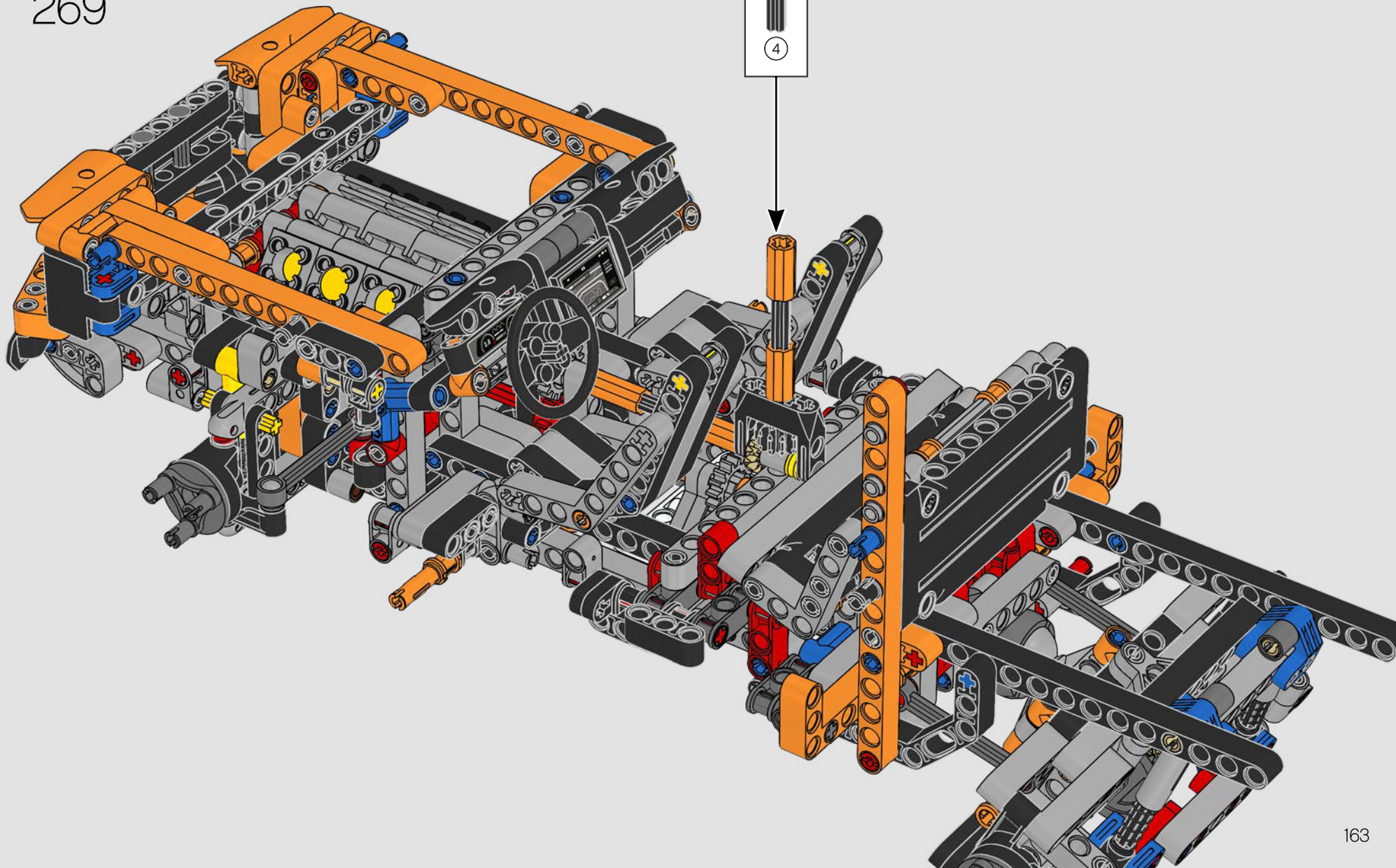
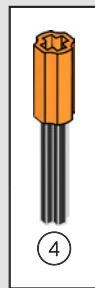

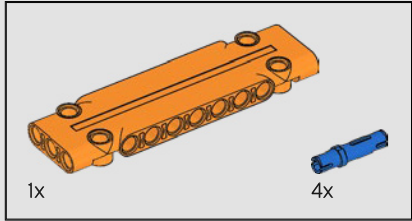
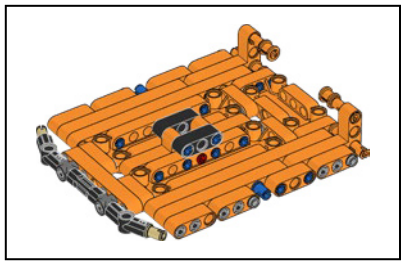

270

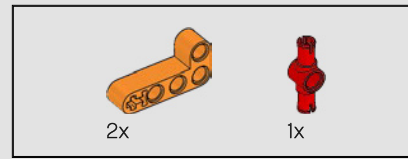
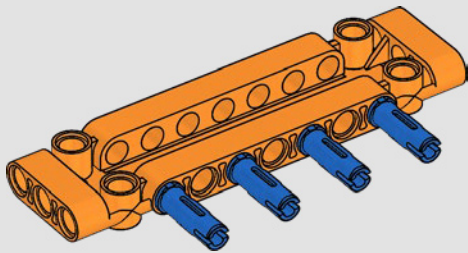

271

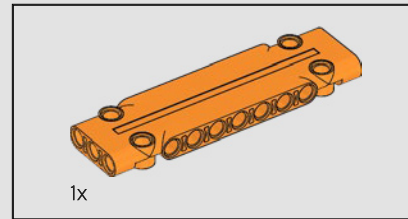
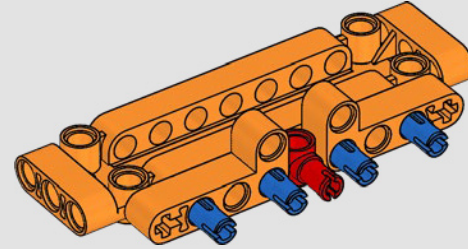

272

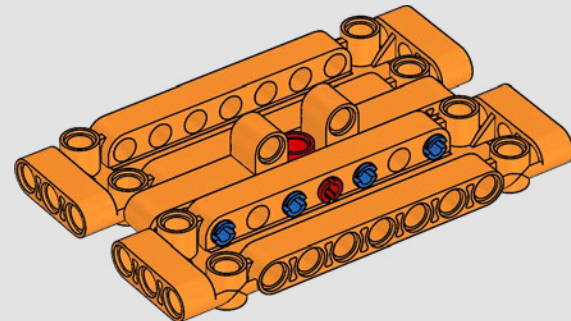

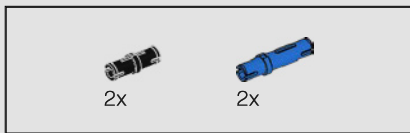

273

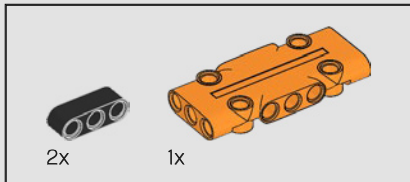
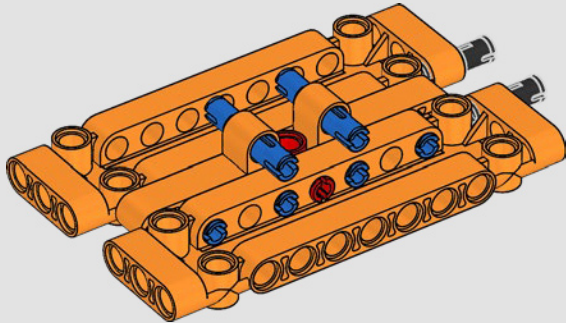

274

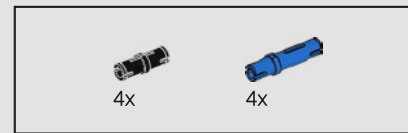
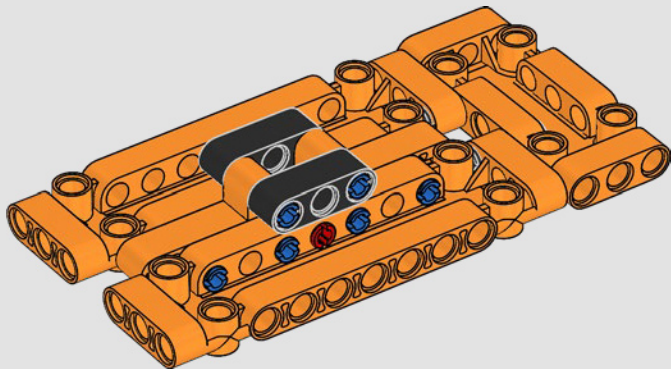

275

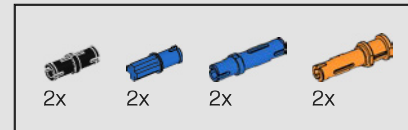
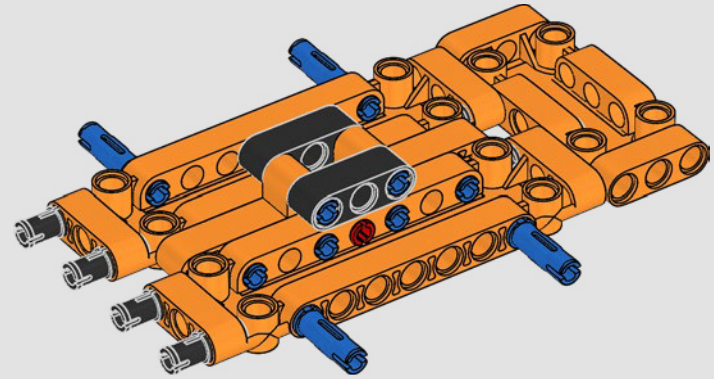

276

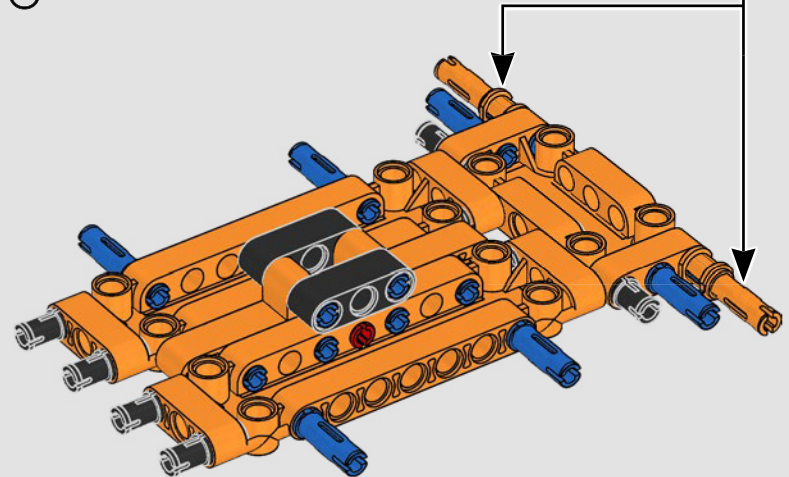
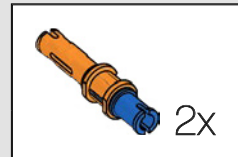

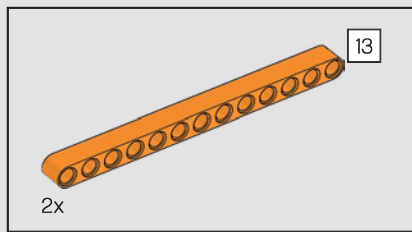

277

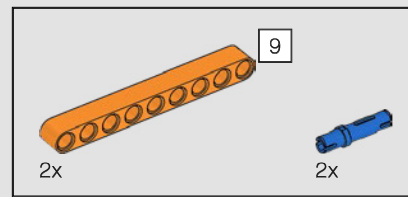
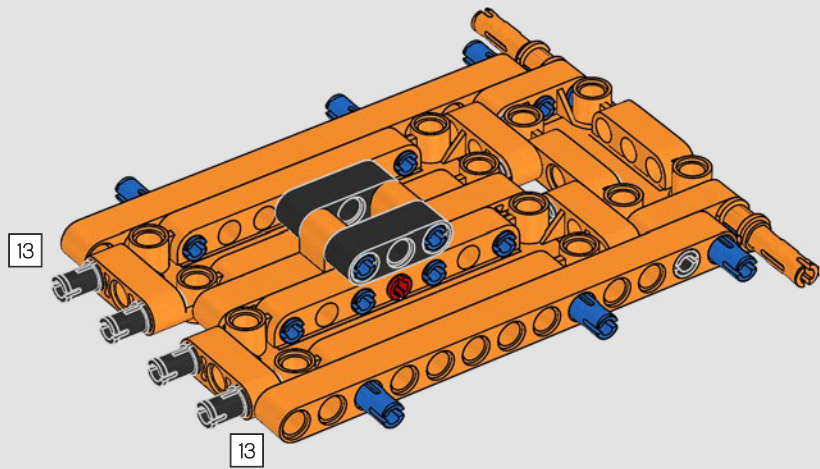

278

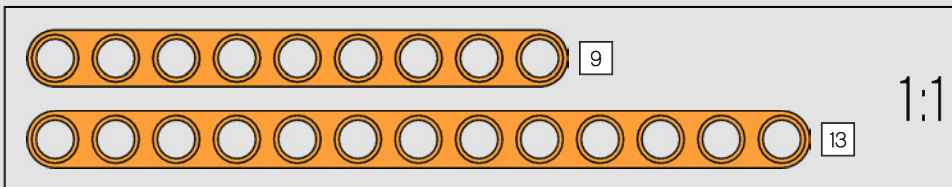
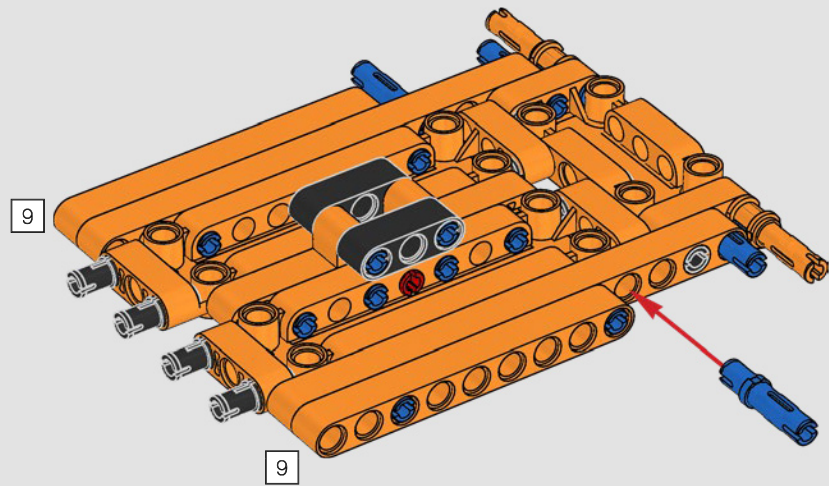

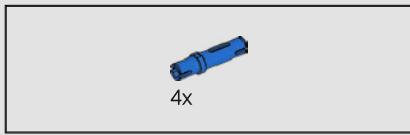

279

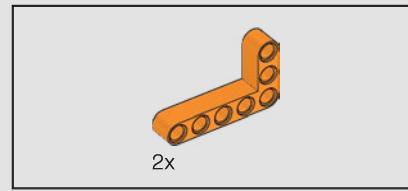
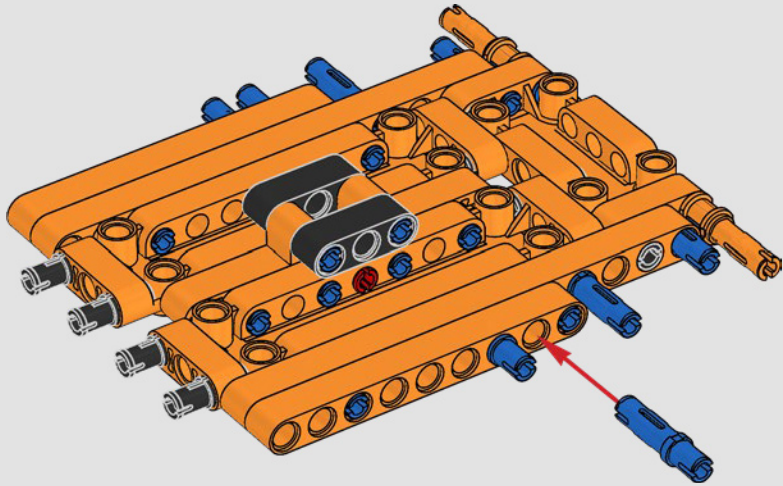

280

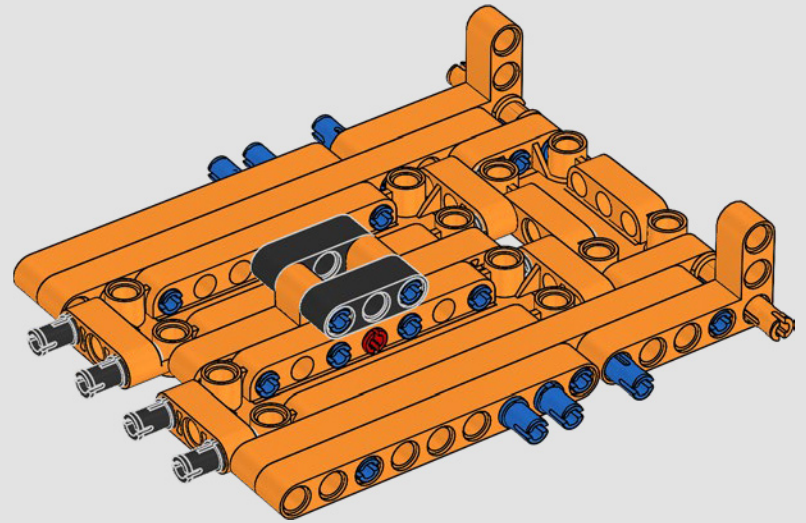



12x

281

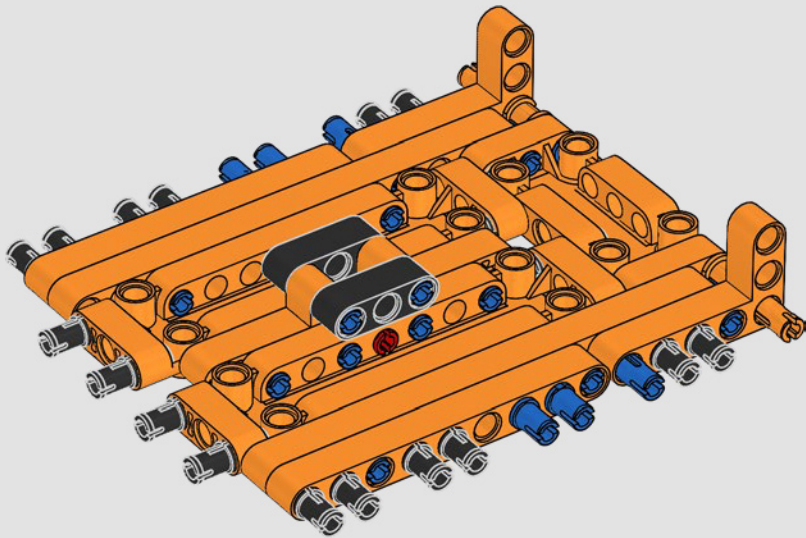

8x

282

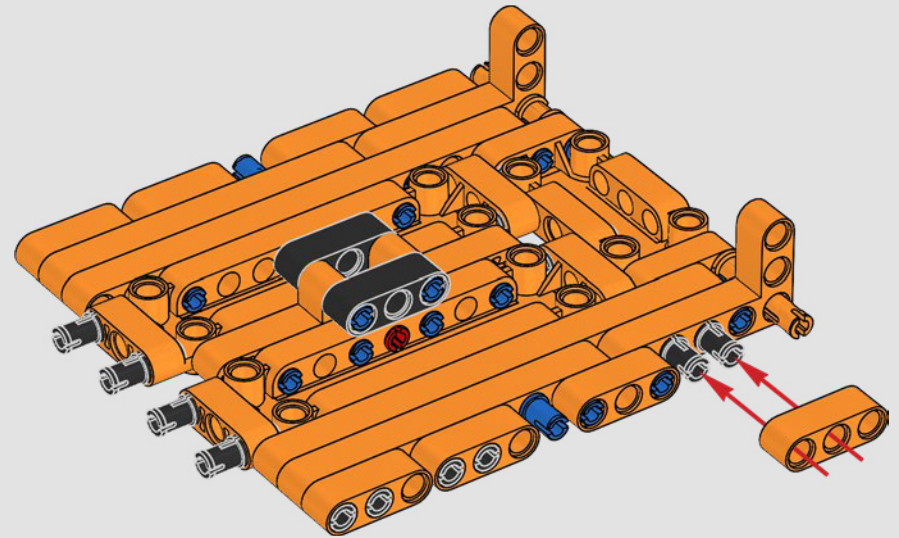

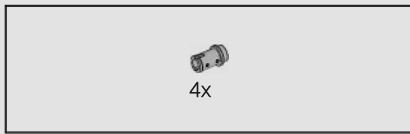

283

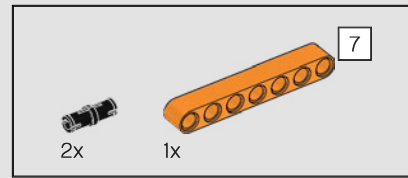
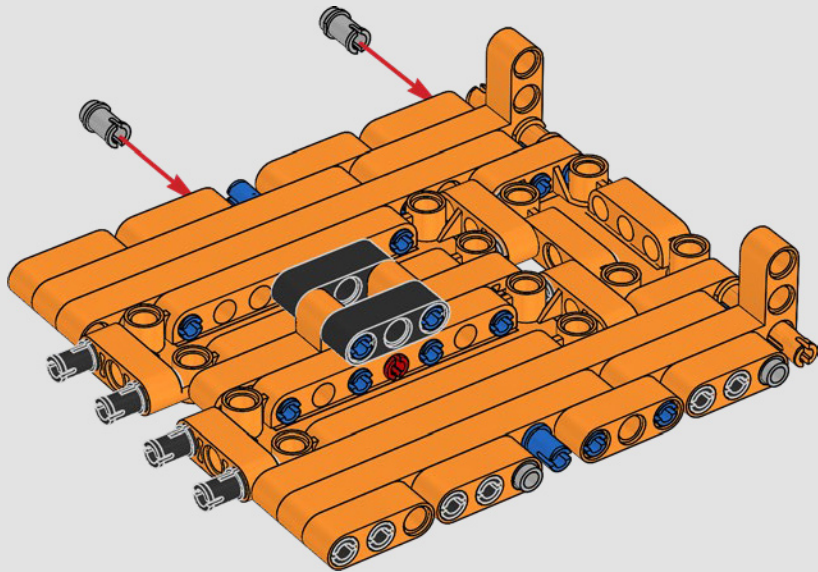

284

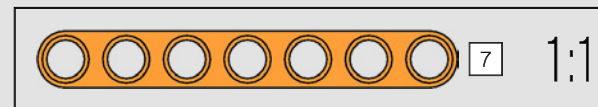
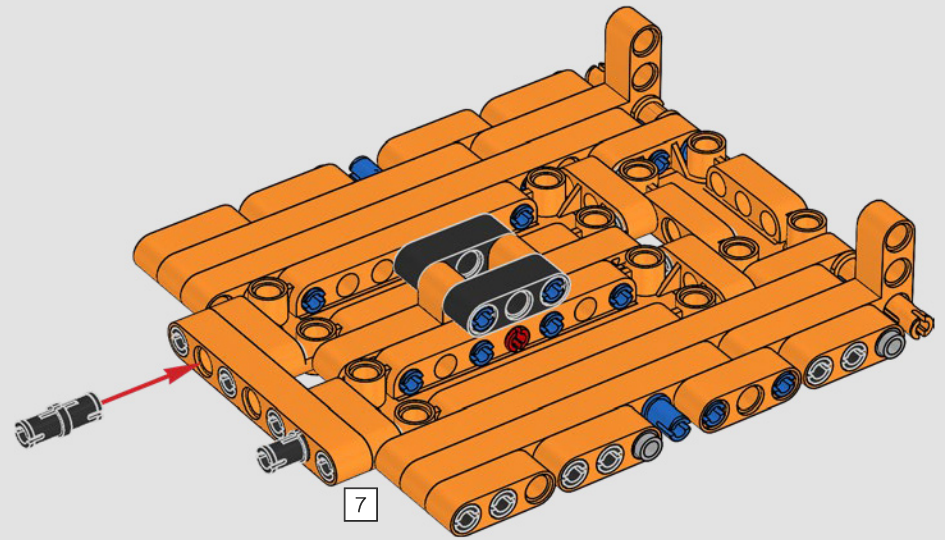

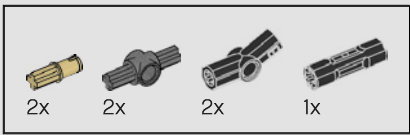

285

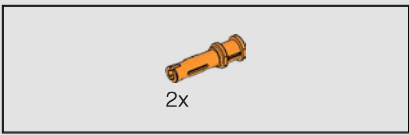
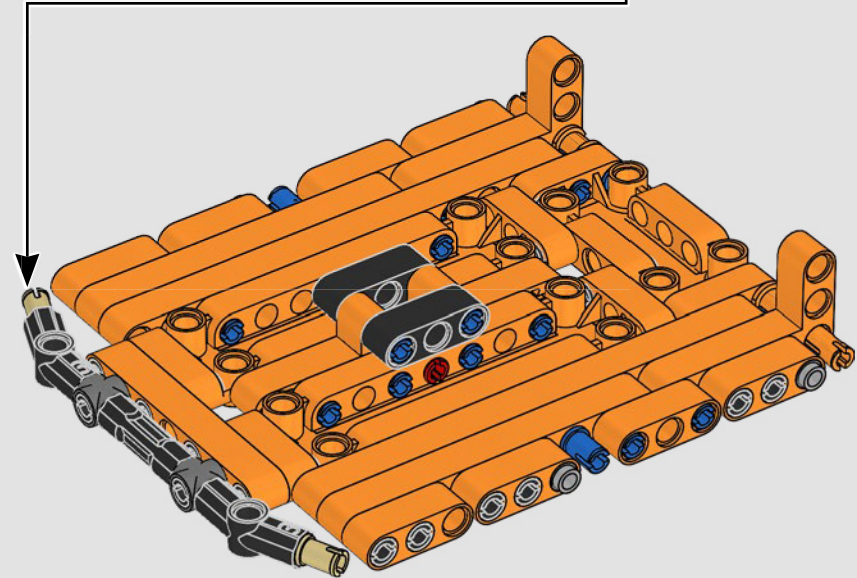
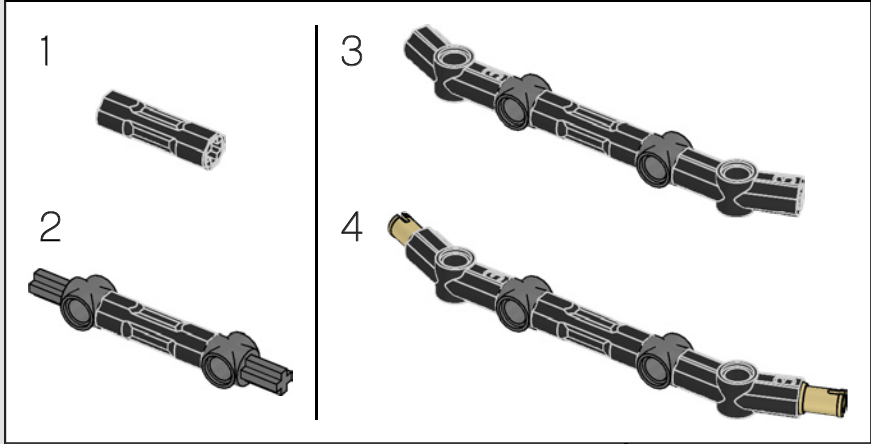

286

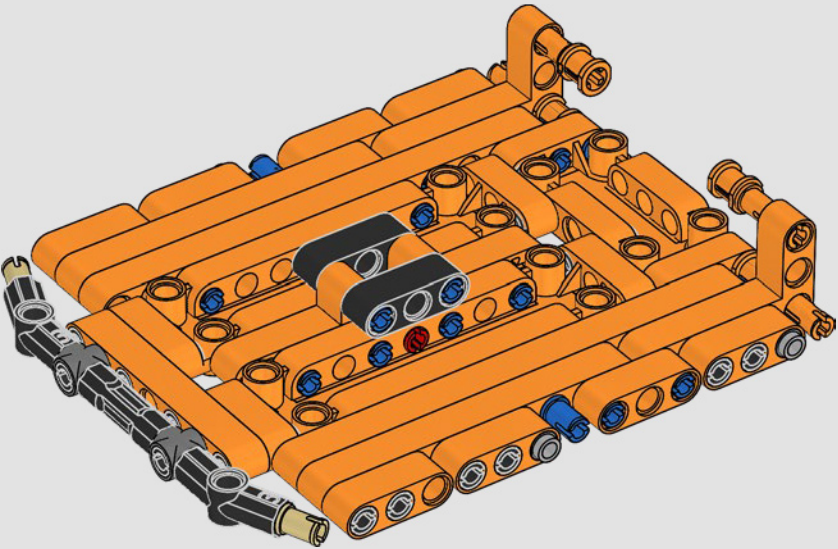

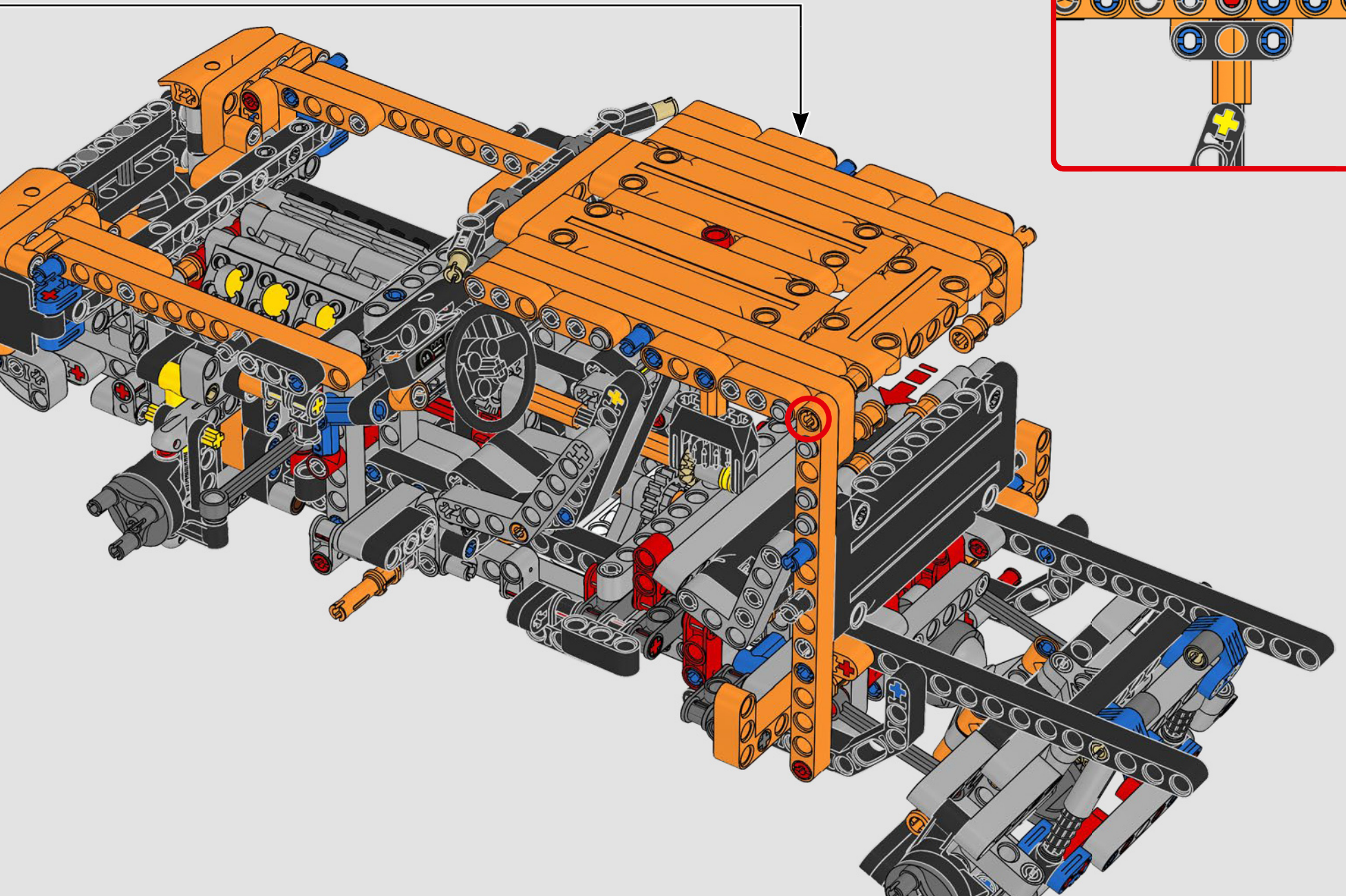

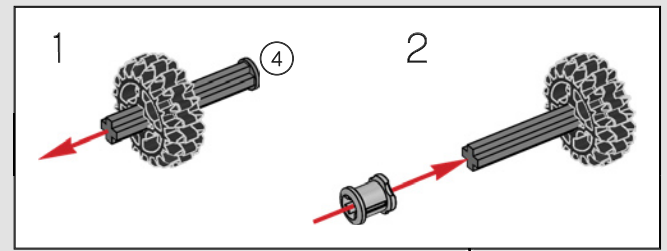
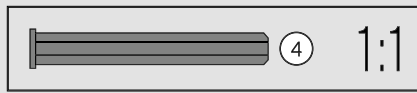
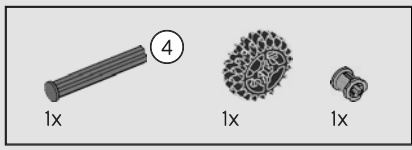

288

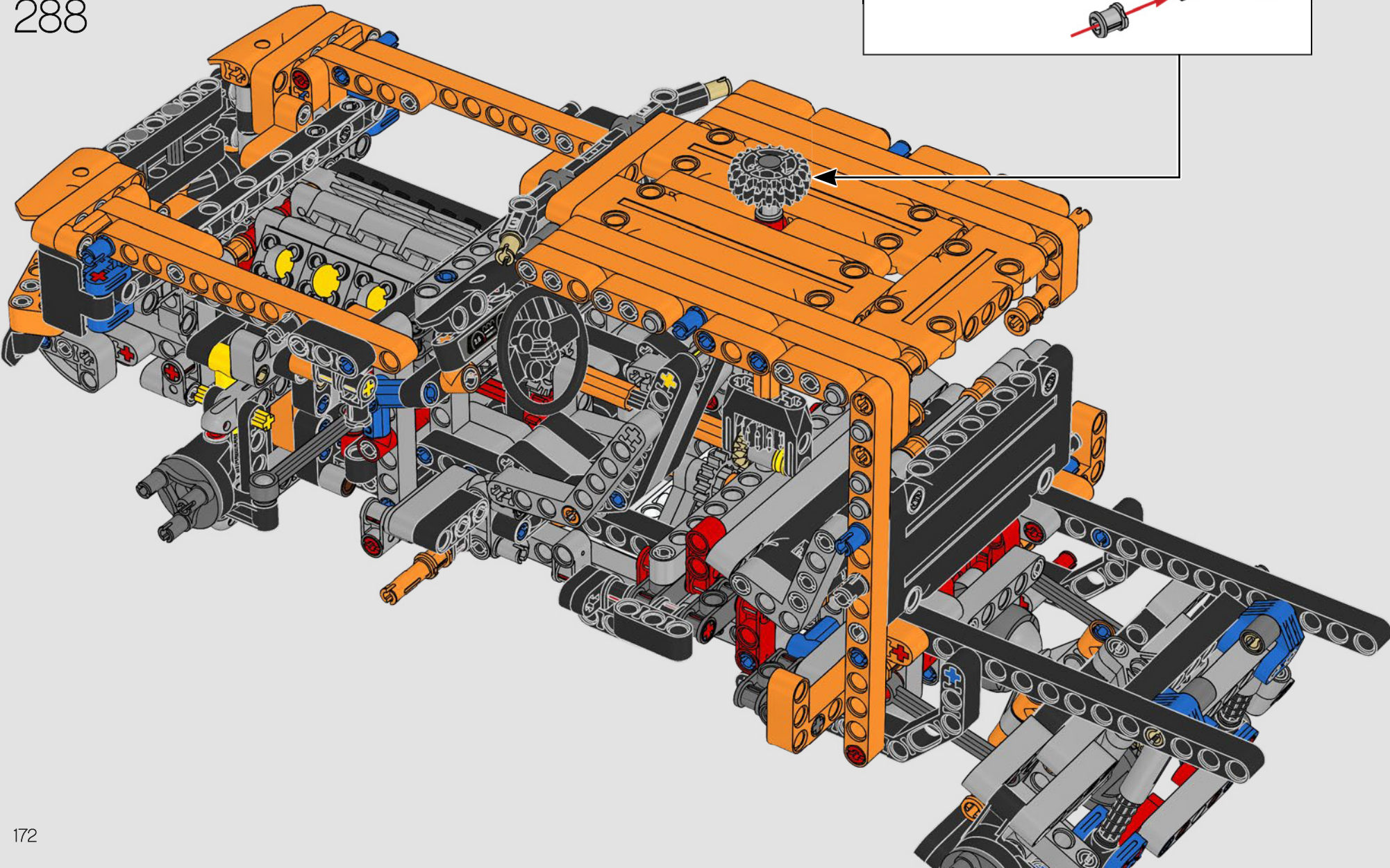

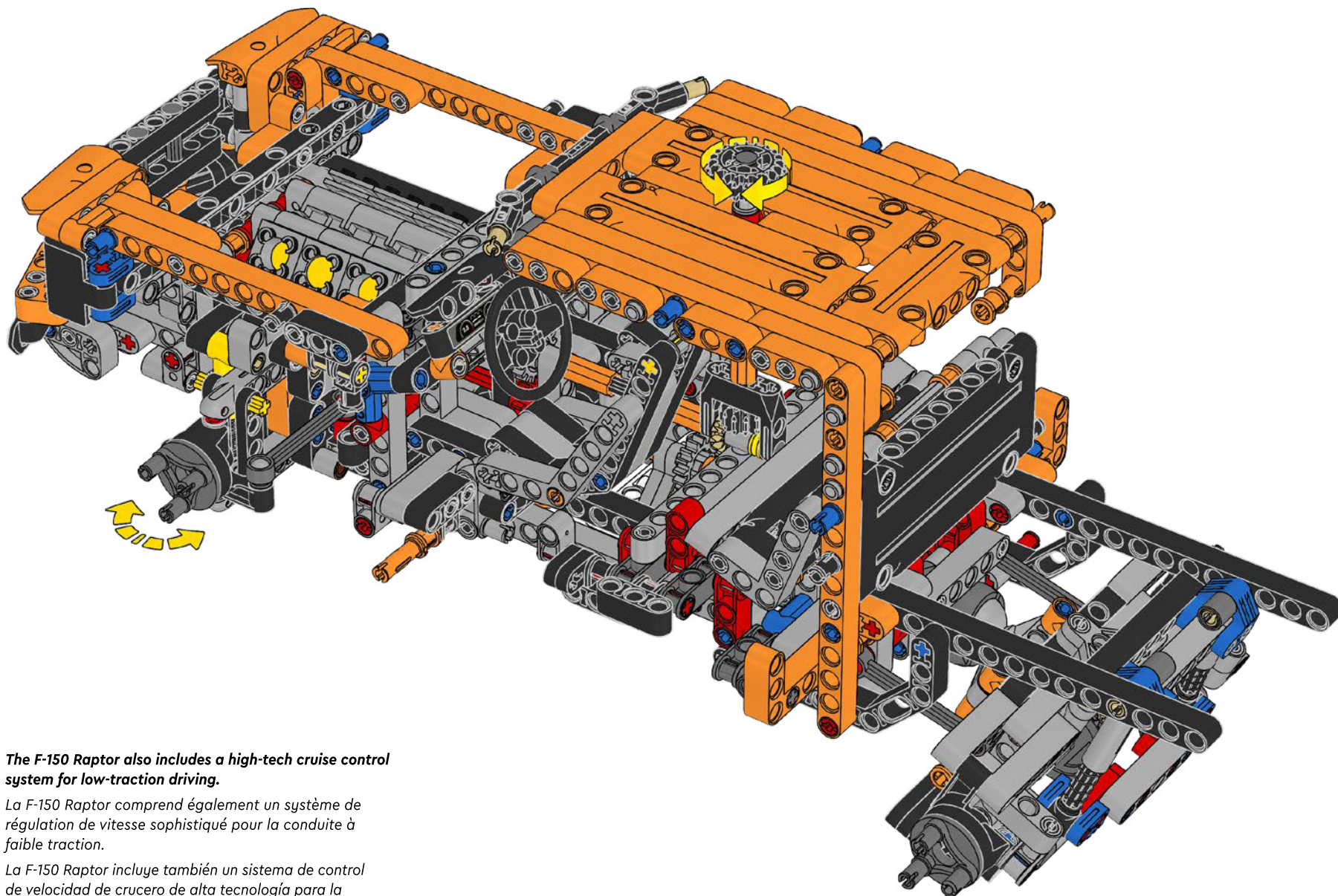

The F-150 Raptor also includes a high-tech cruise control system for low-traction driving.

La F-150 Raptor comprend également un système de régulation de vitesse sophistiqué pour la conduite à faible traction.

La F-150 Raptor incluye también un sistema de control de velocidad de crucero de alta tecnología para la conducción en terrenos de baja tracción.

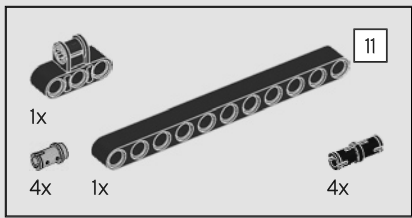

289

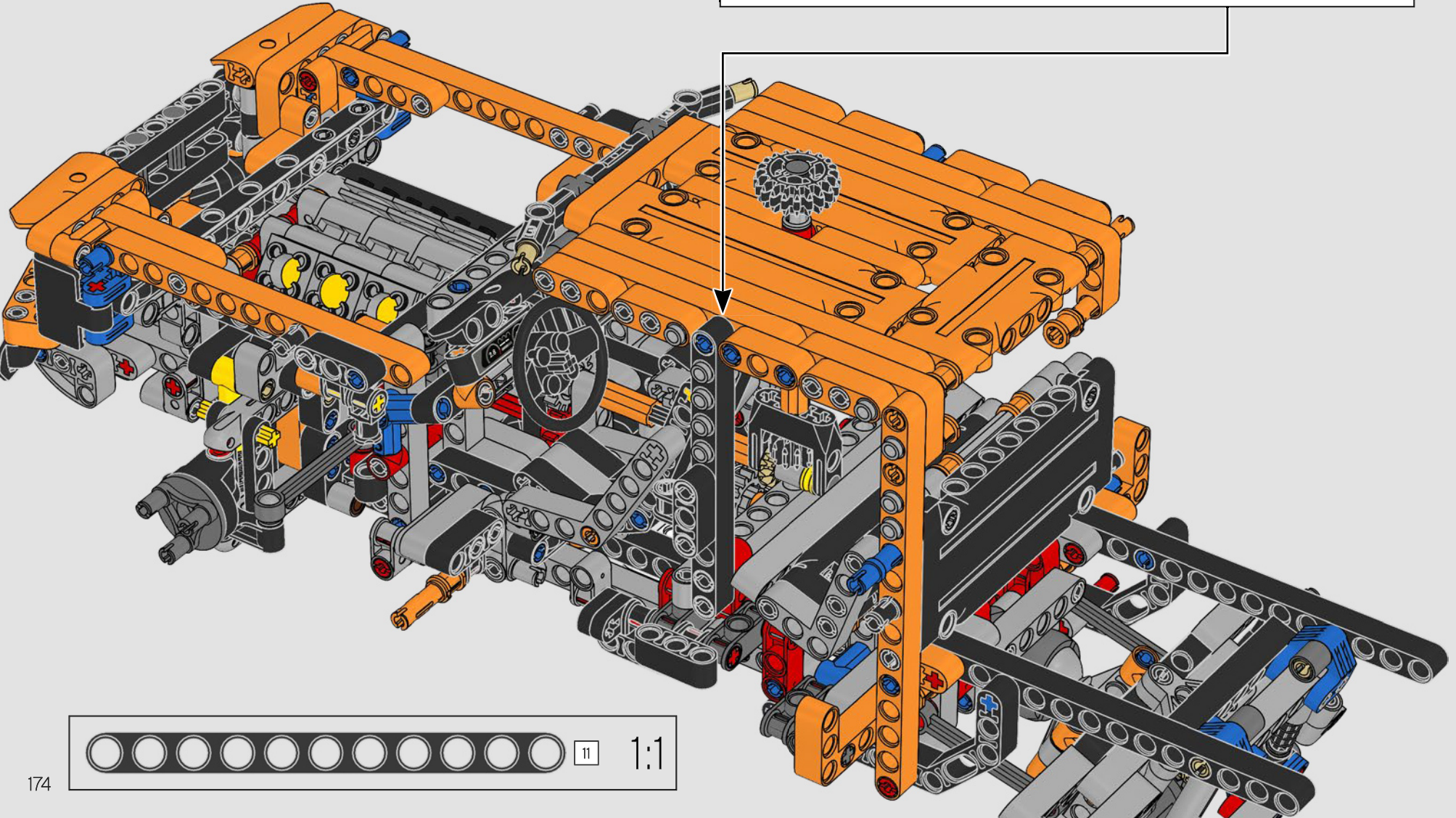
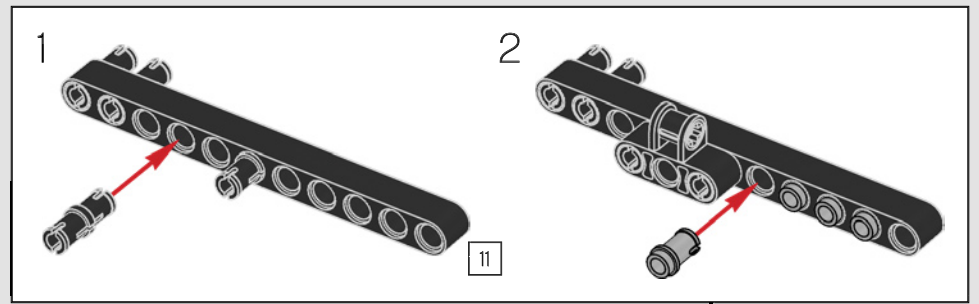

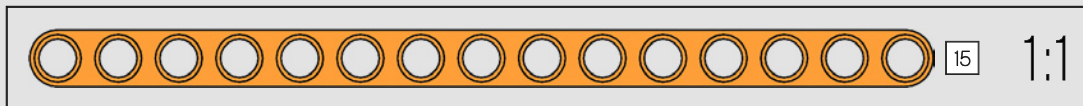
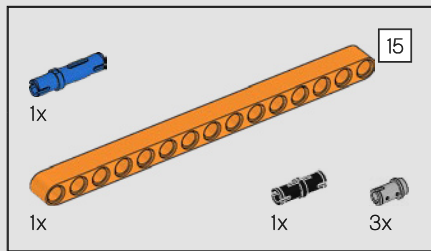

290

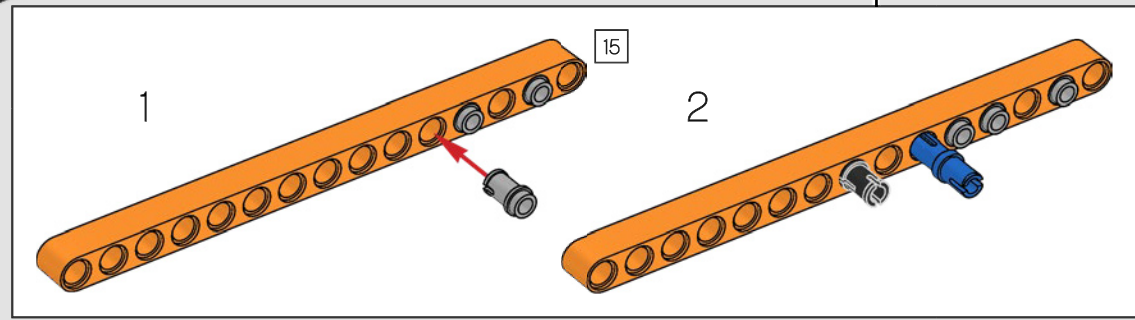
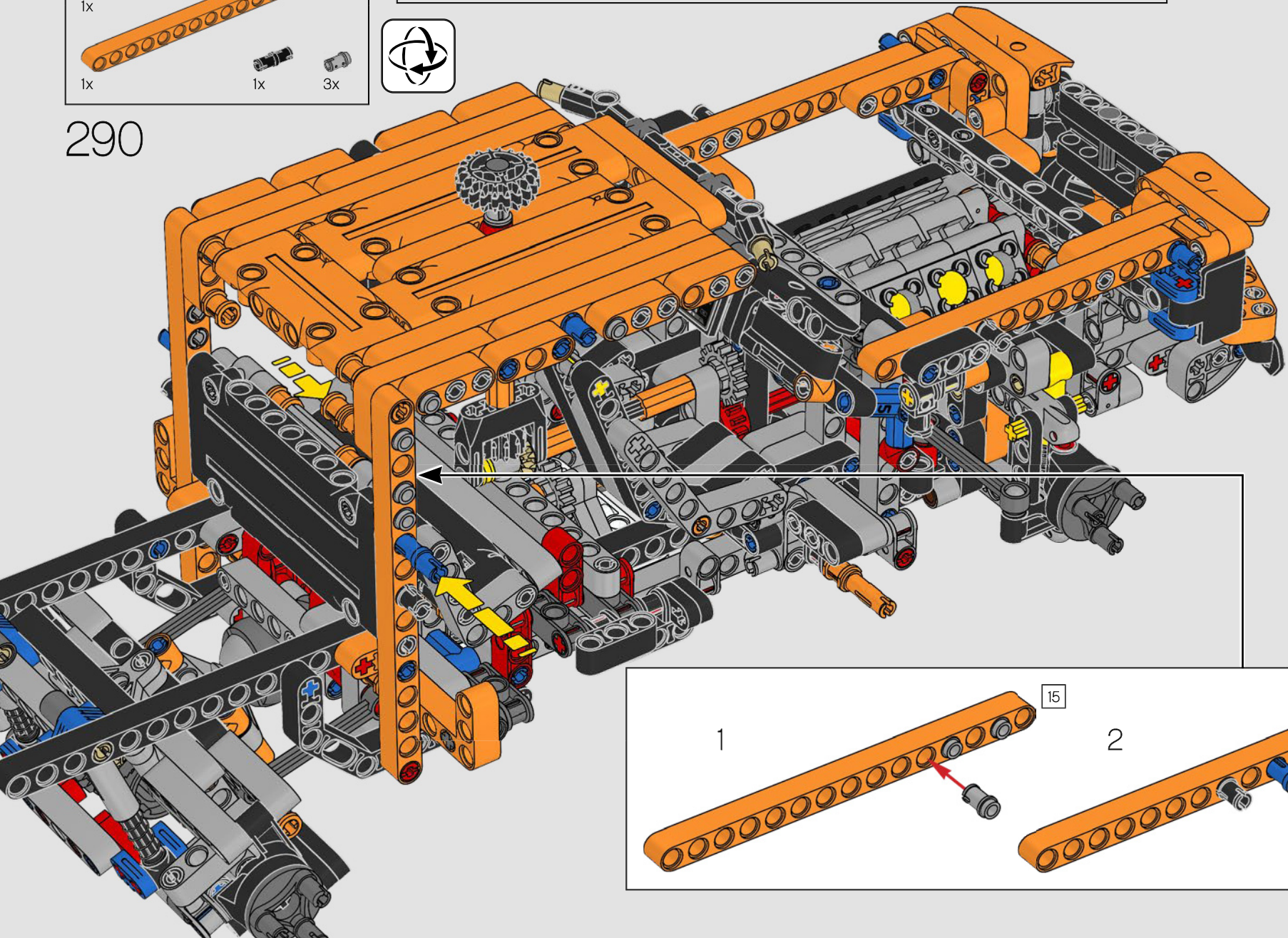

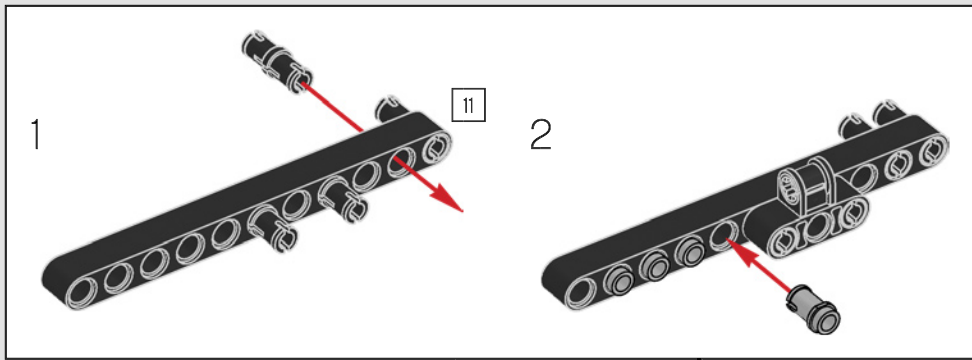
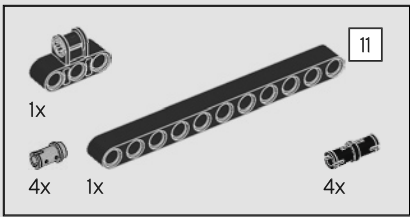

291

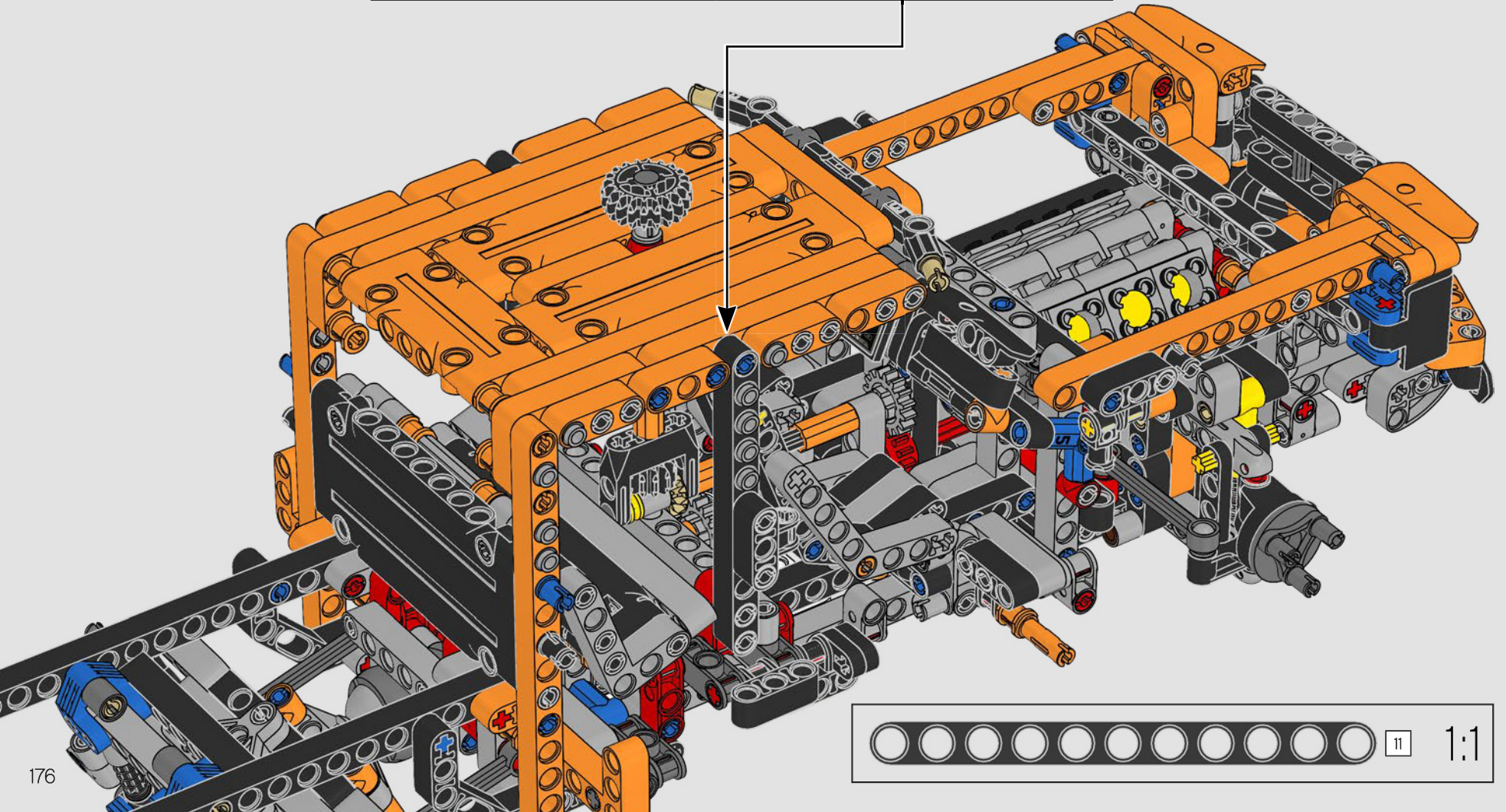



292

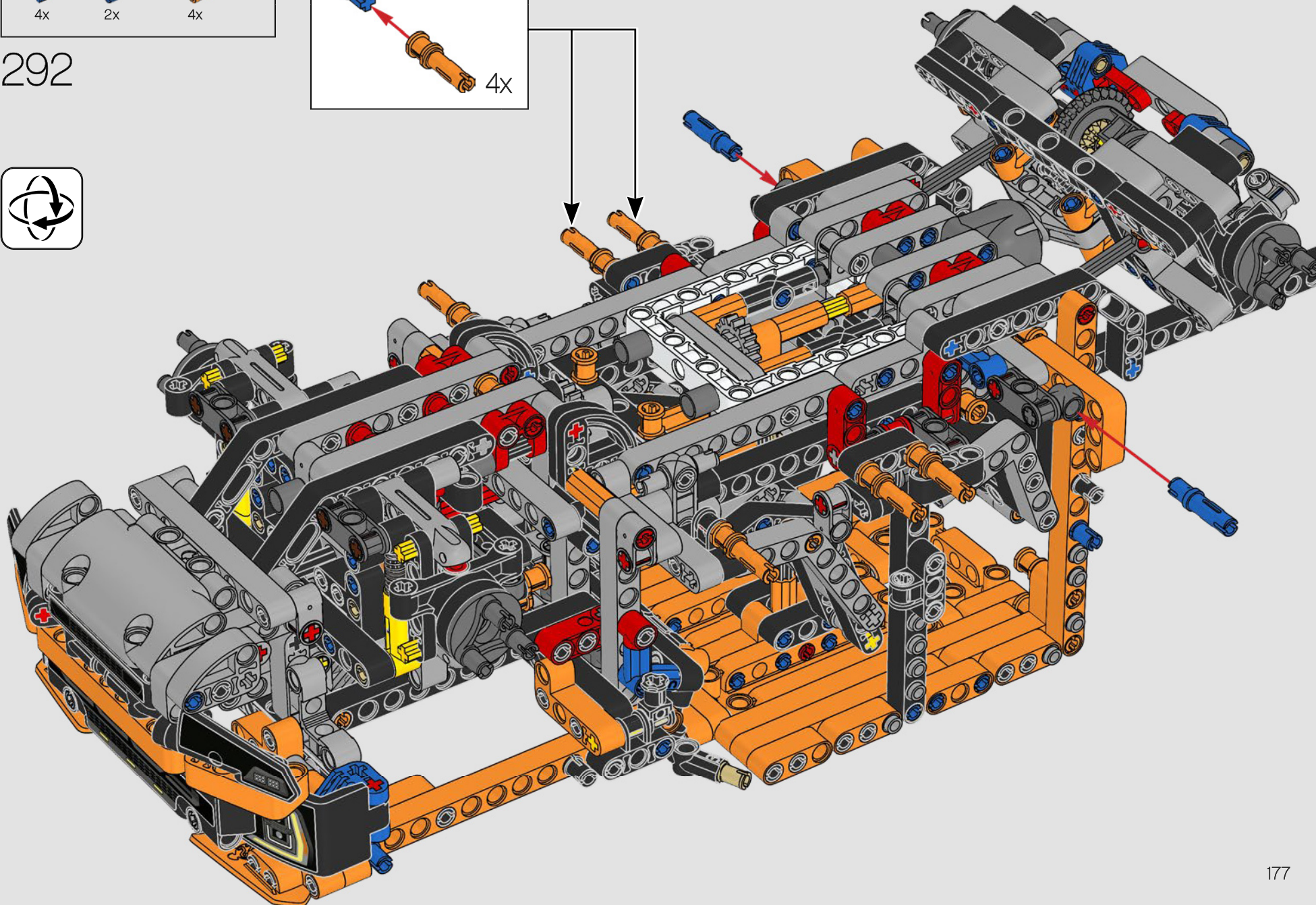
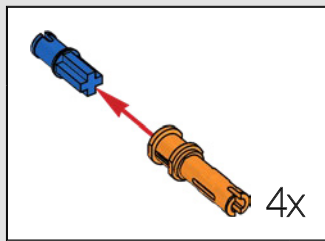

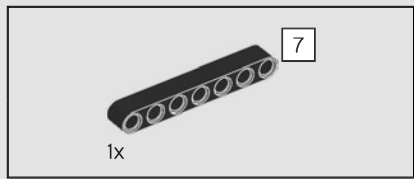

293

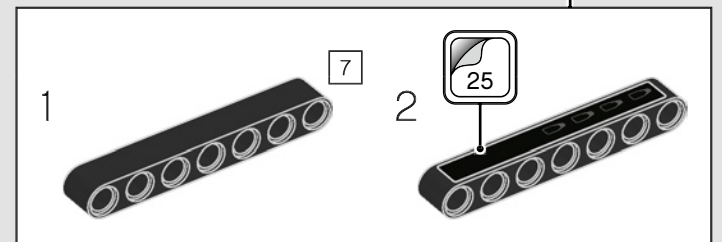
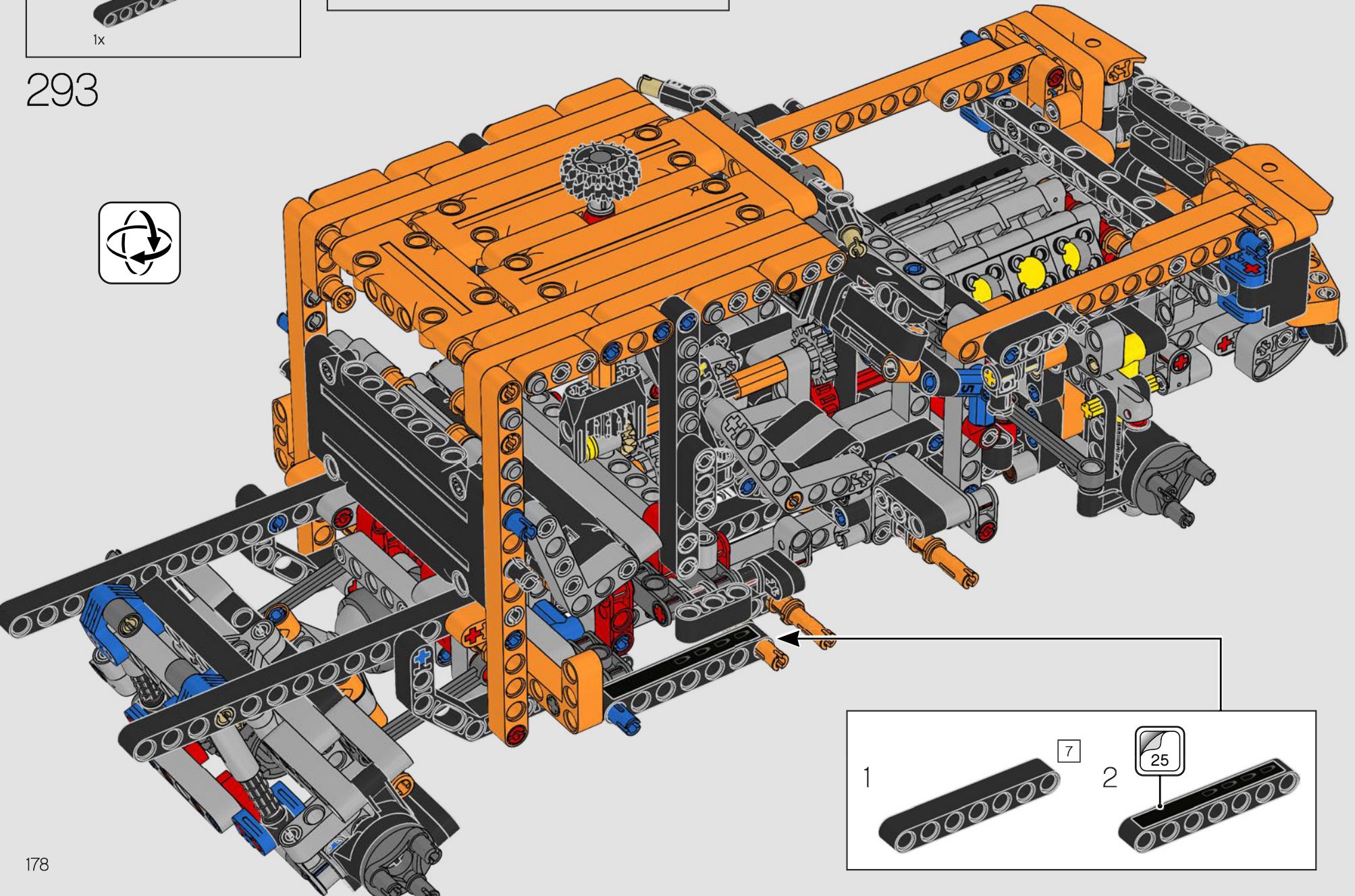

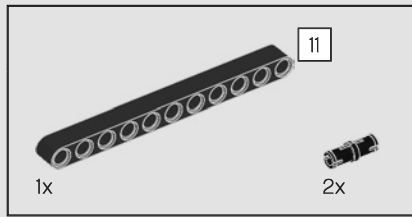

294

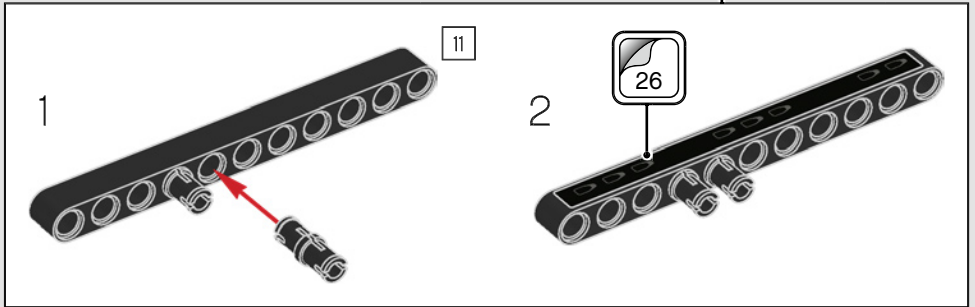
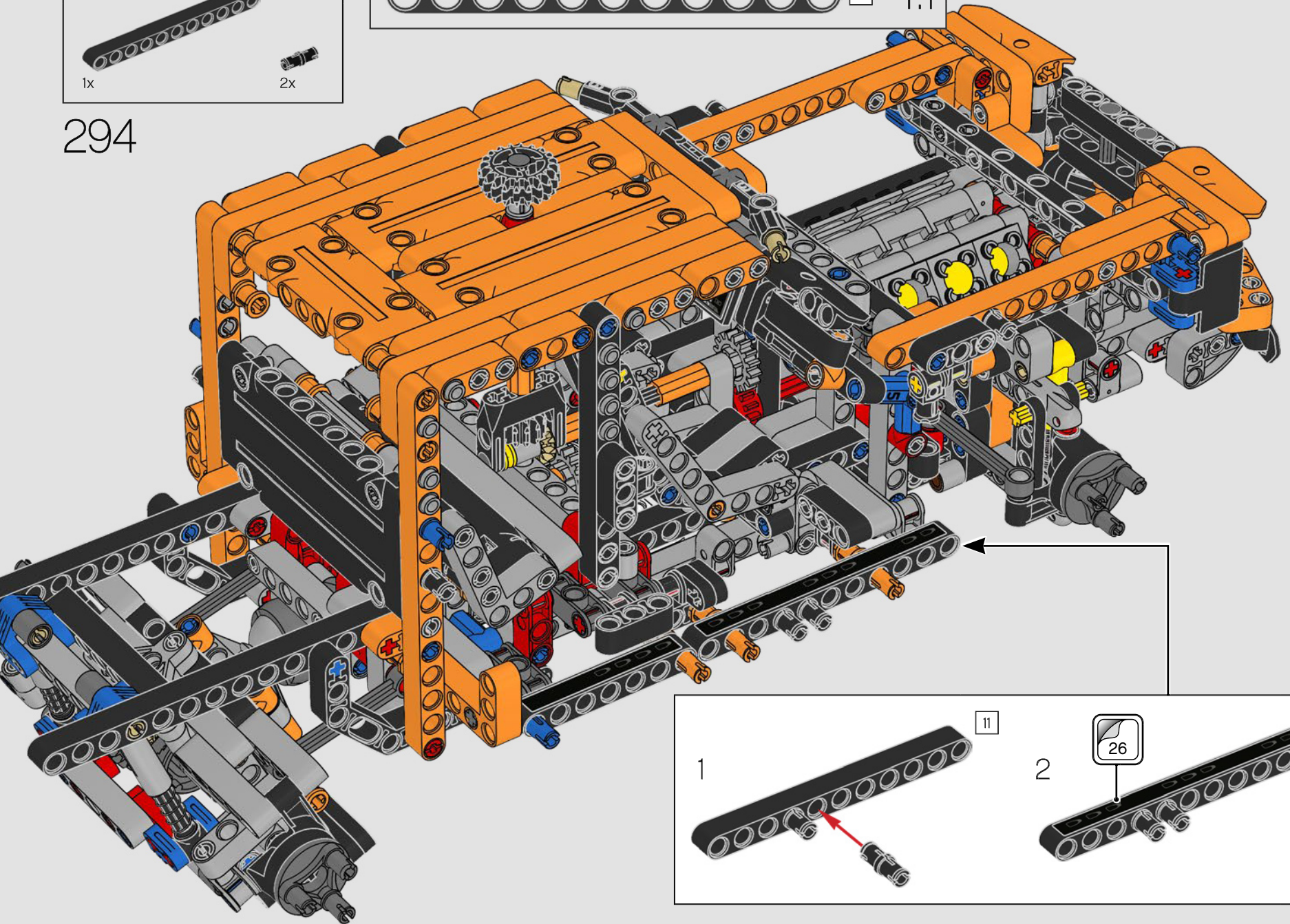

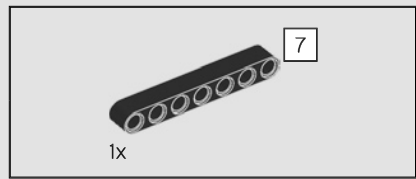

295

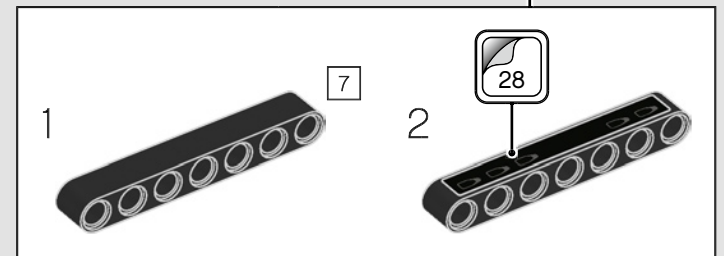
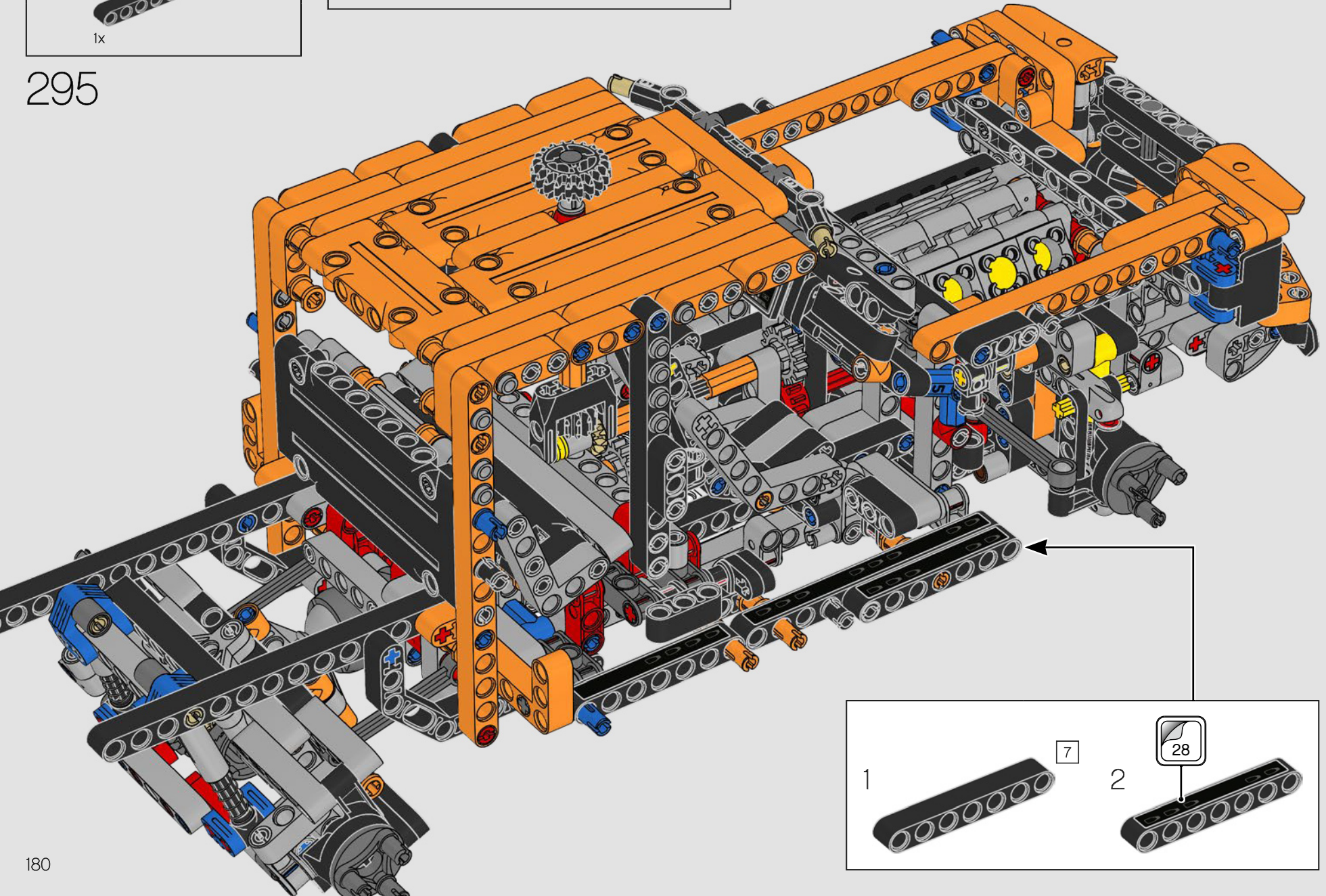

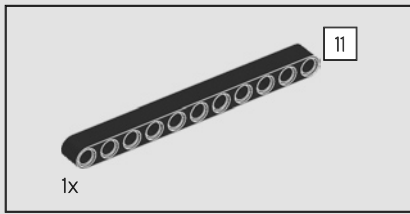

296

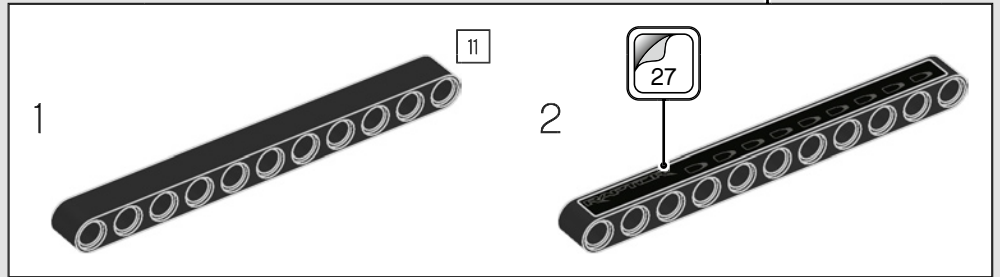
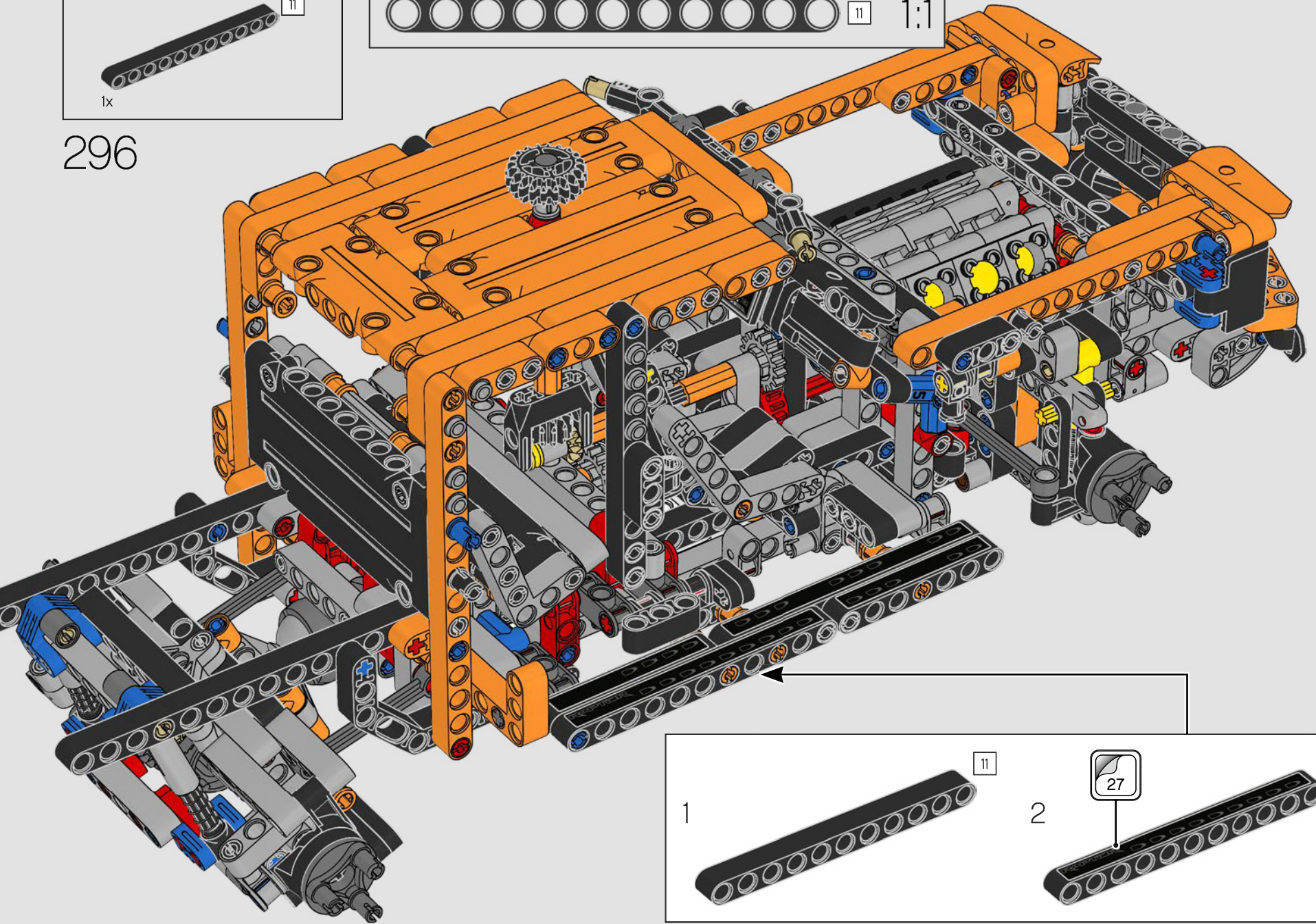

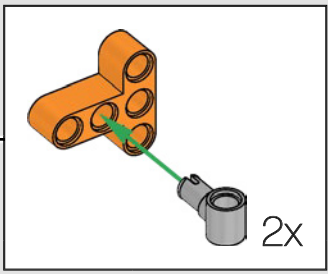
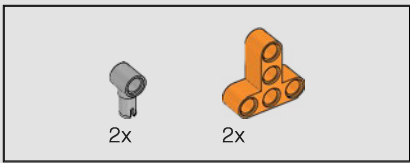

297

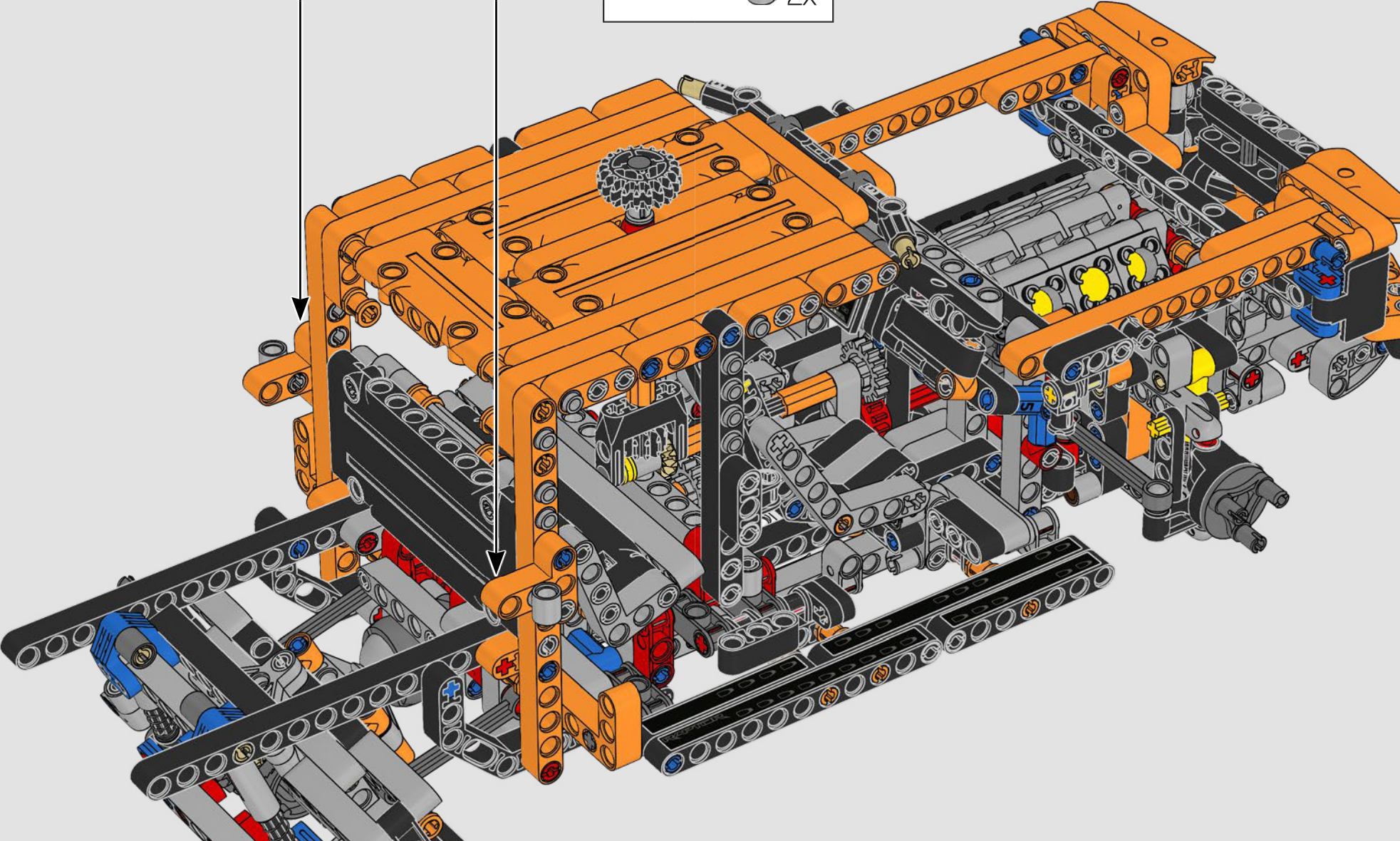

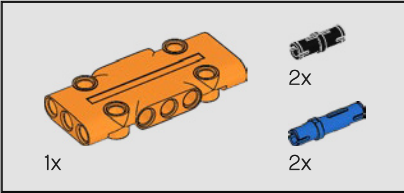
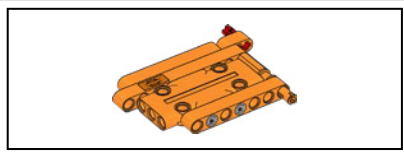

298

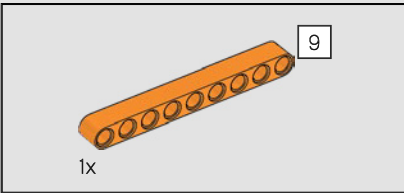
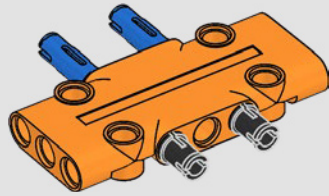

299

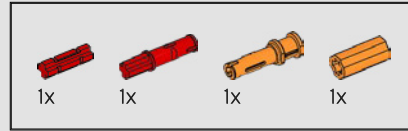
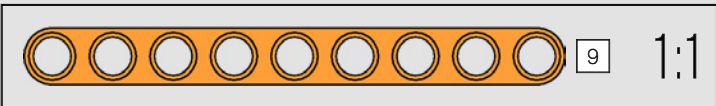
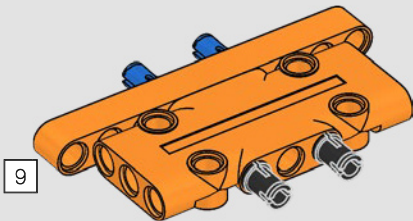

300

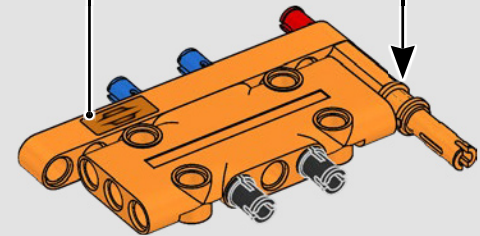
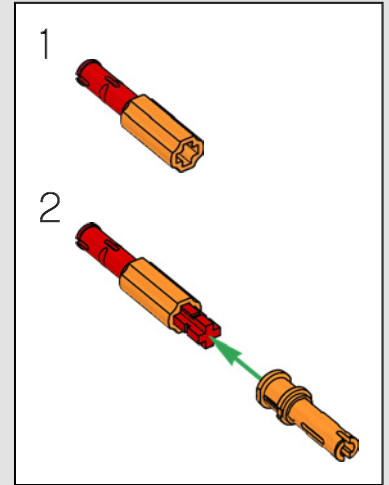

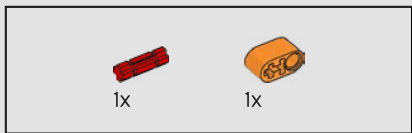

301

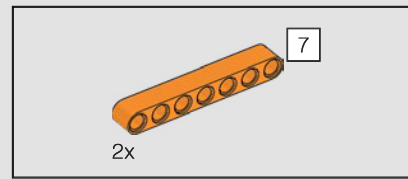
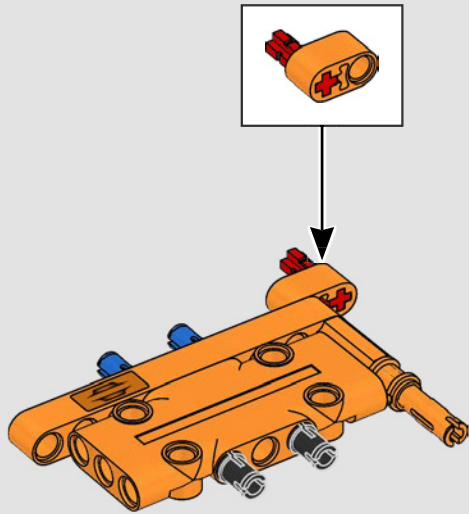

302

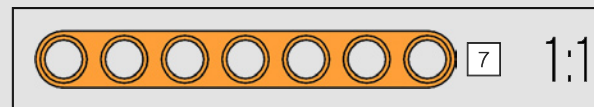
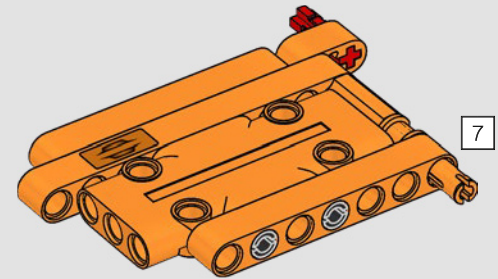

303

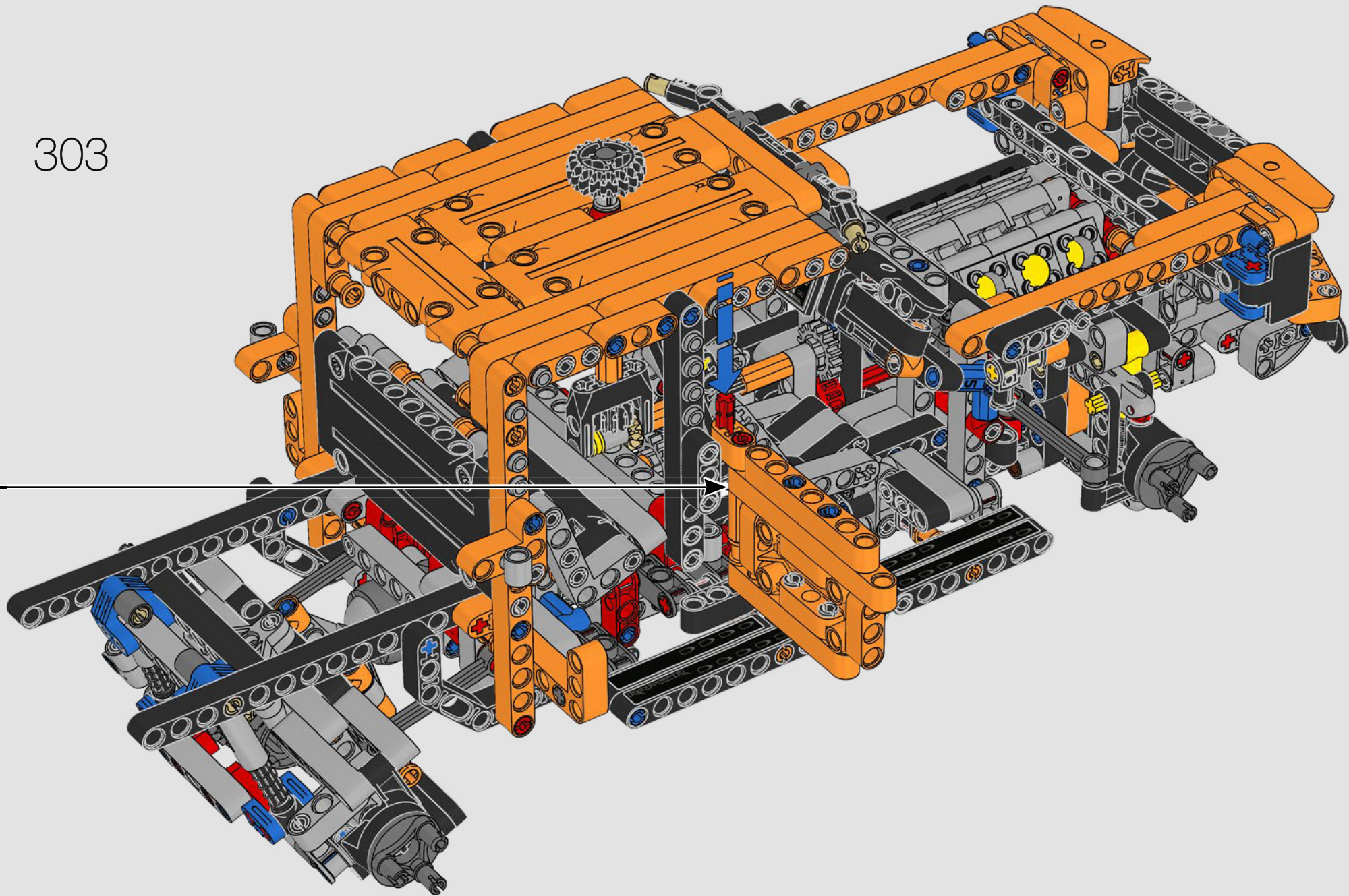

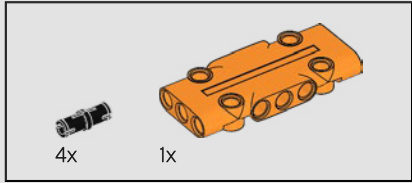
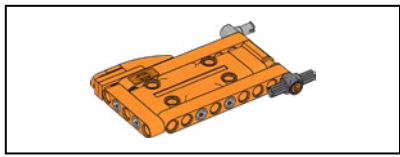

304

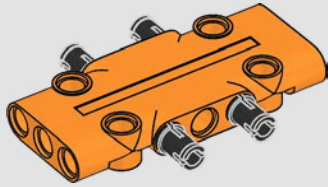

305

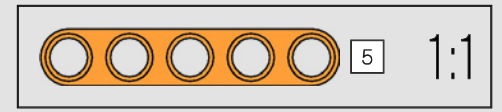
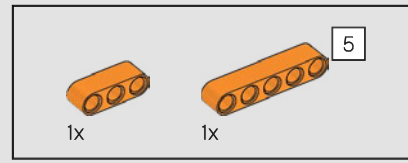
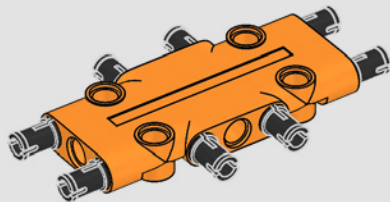

306

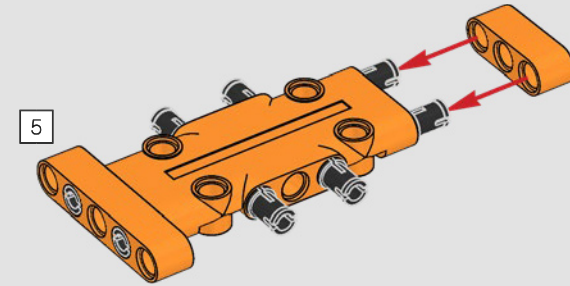

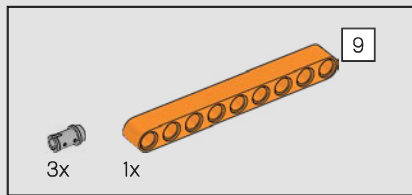

307

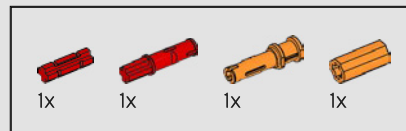
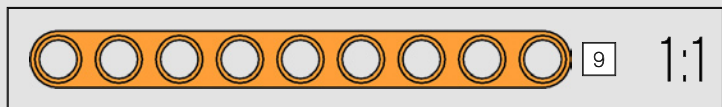
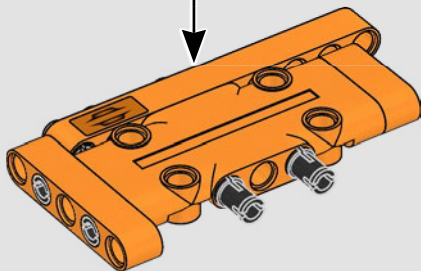
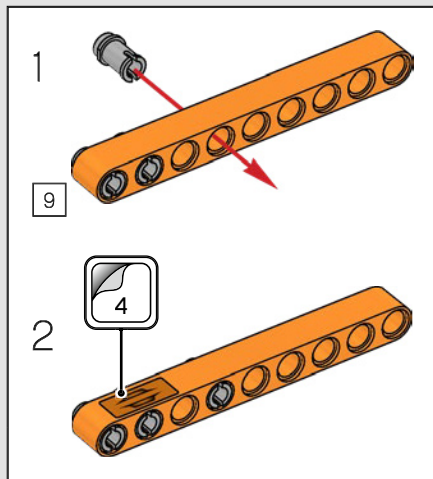

308

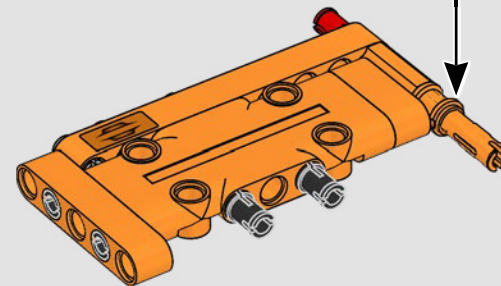
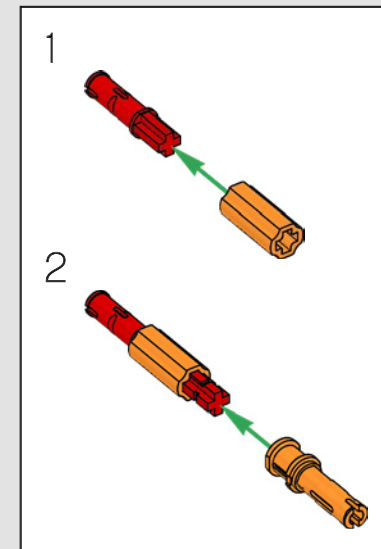

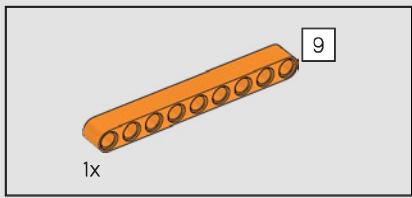

309

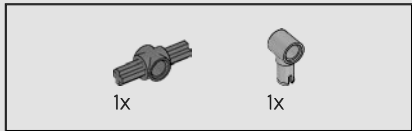
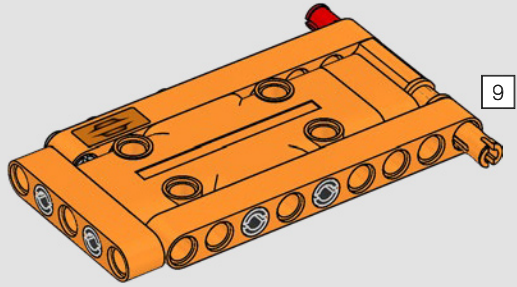

310

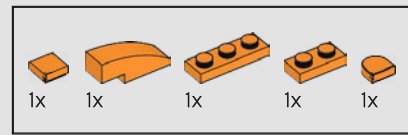
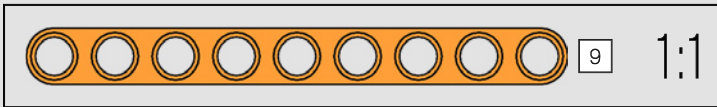
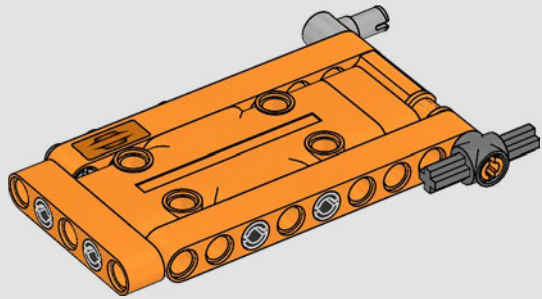

311

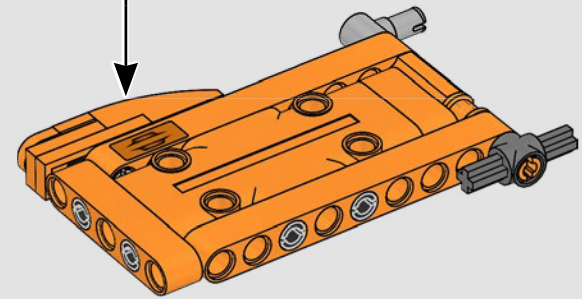
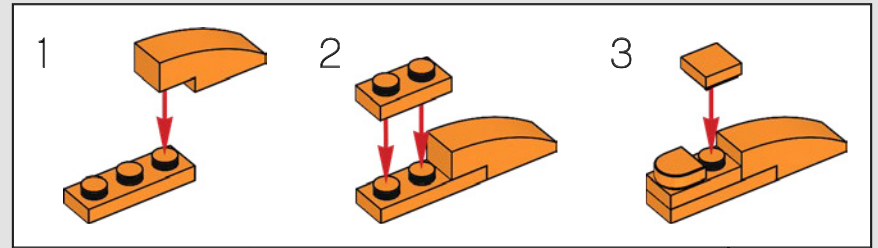

312

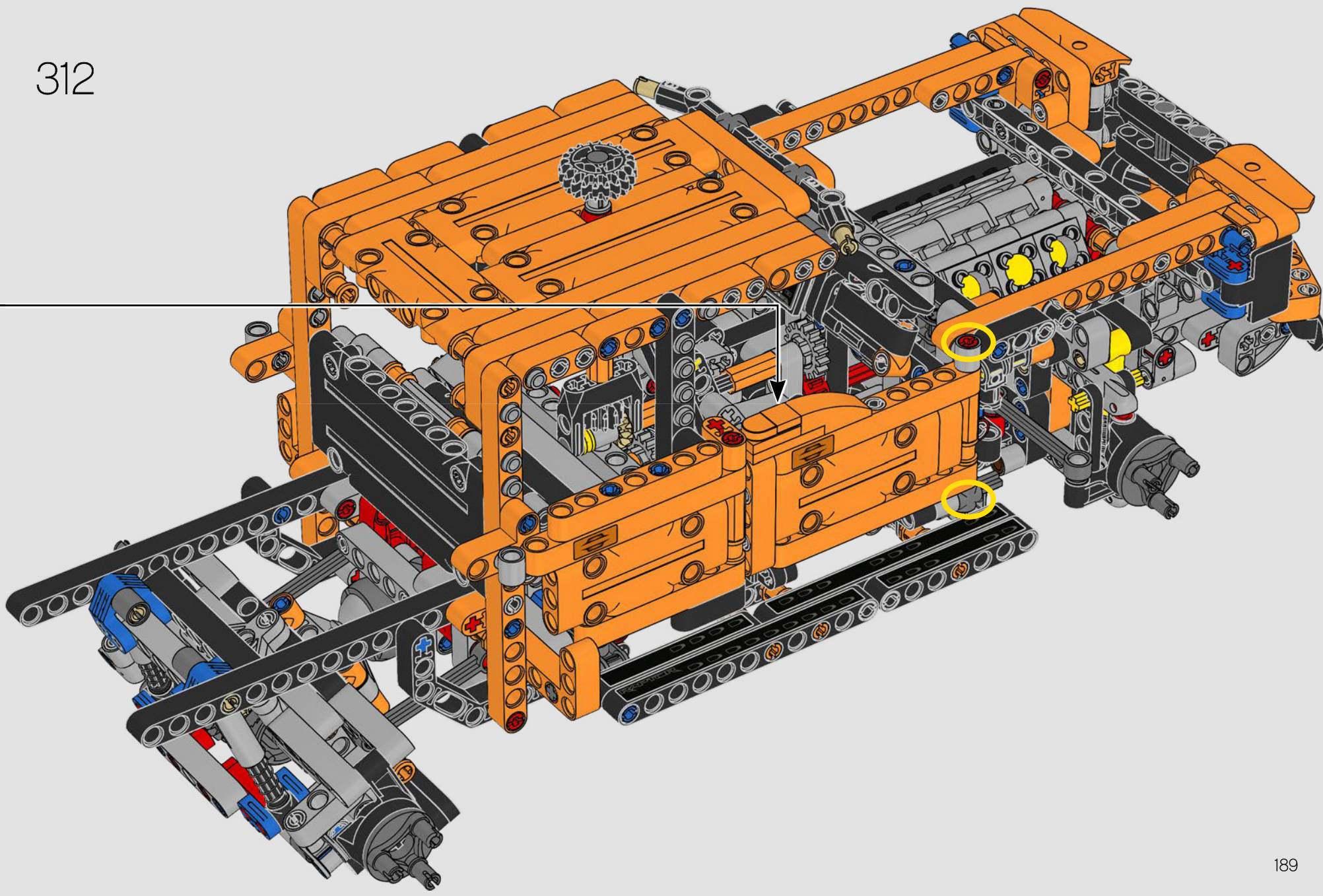

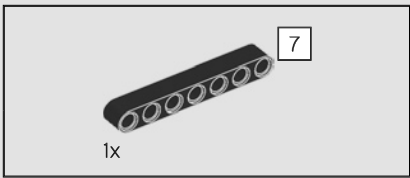

313

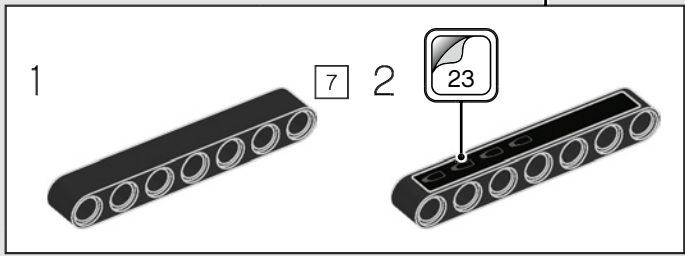
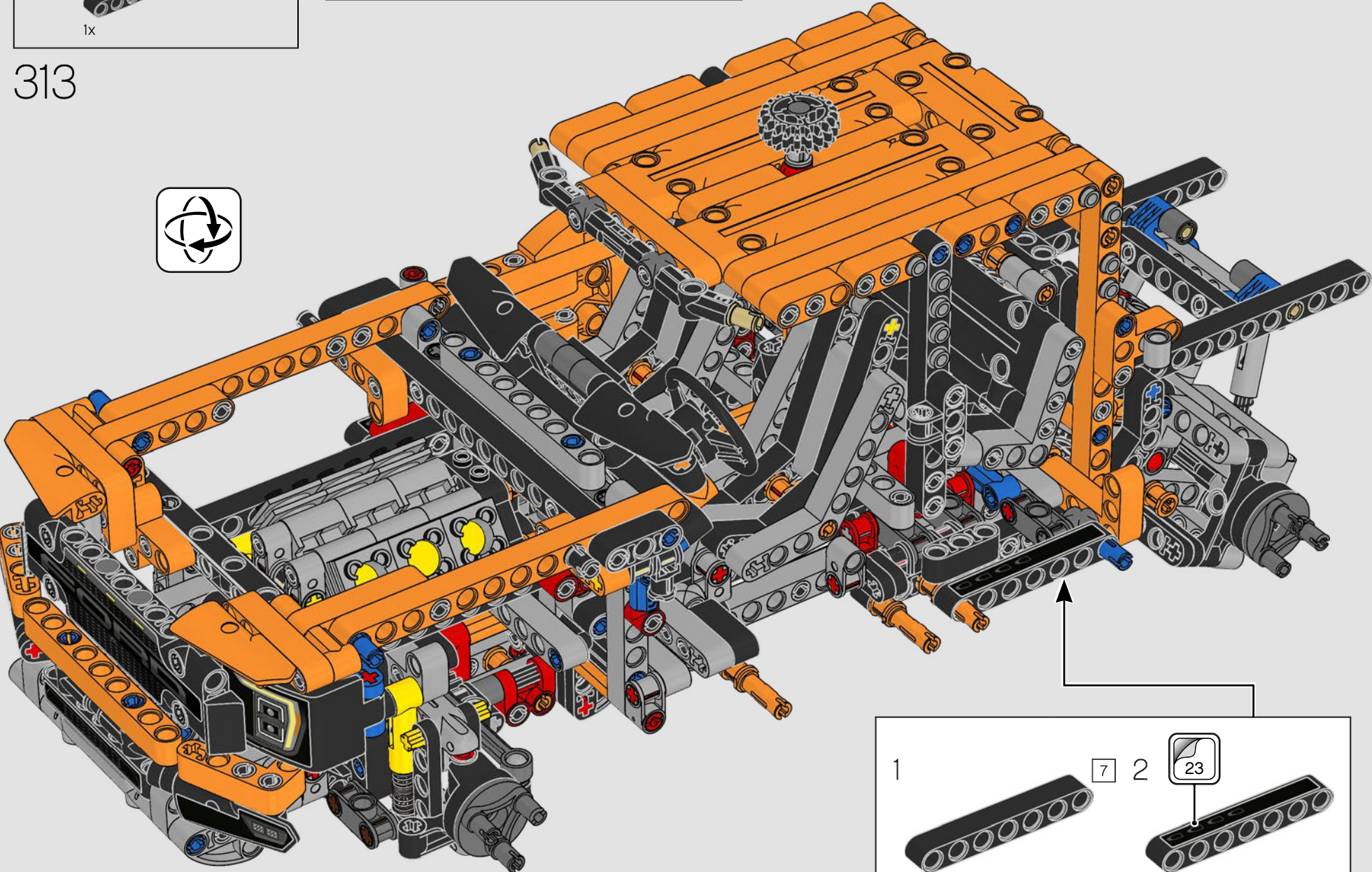

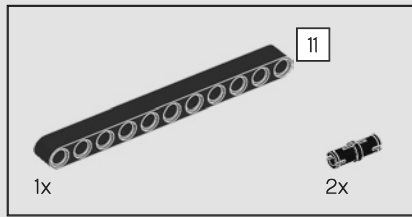

314

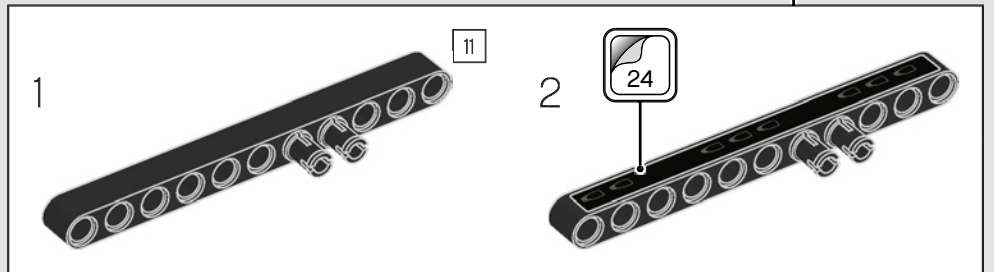
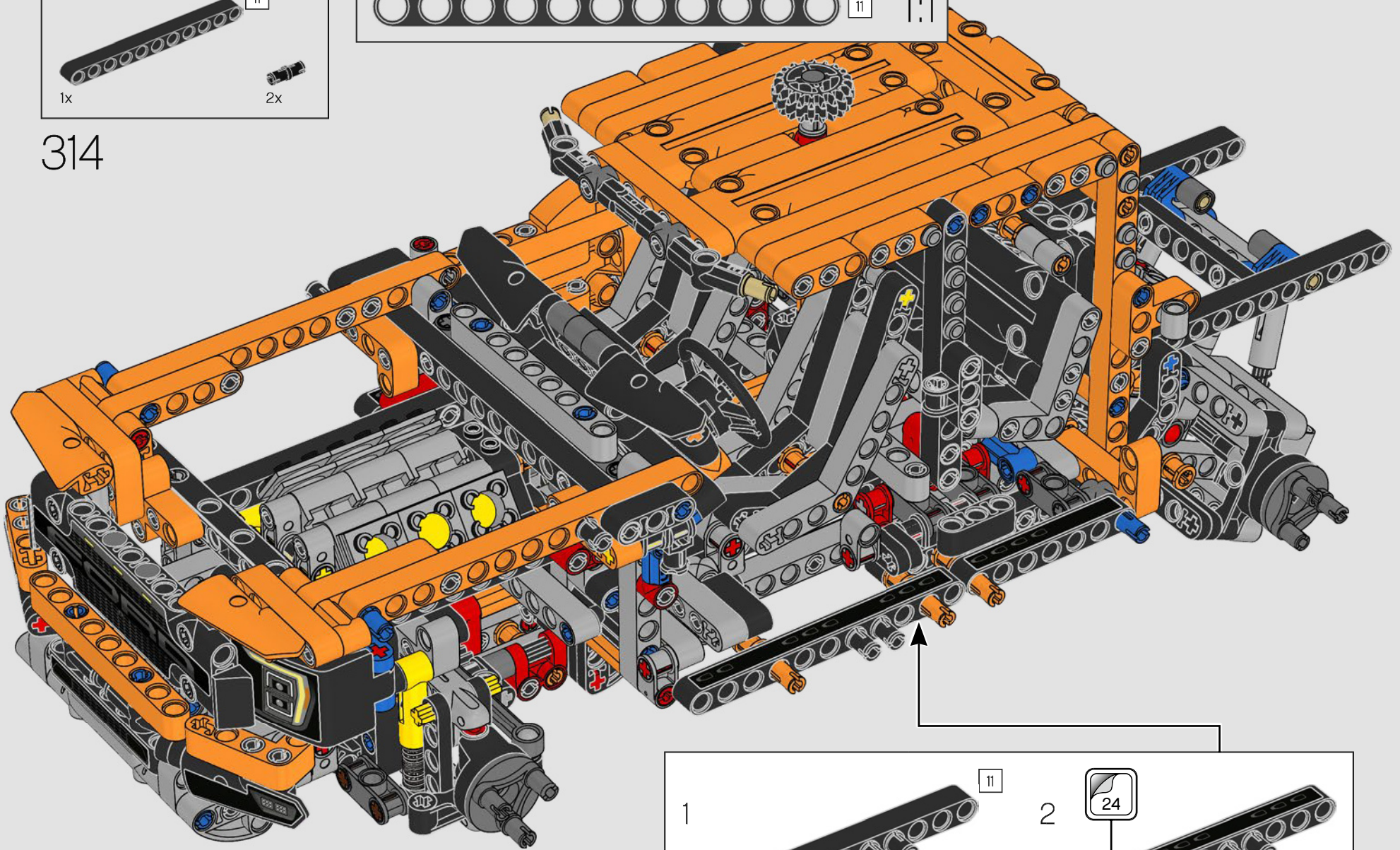

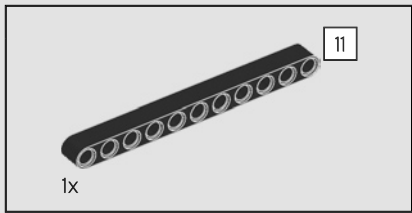

315

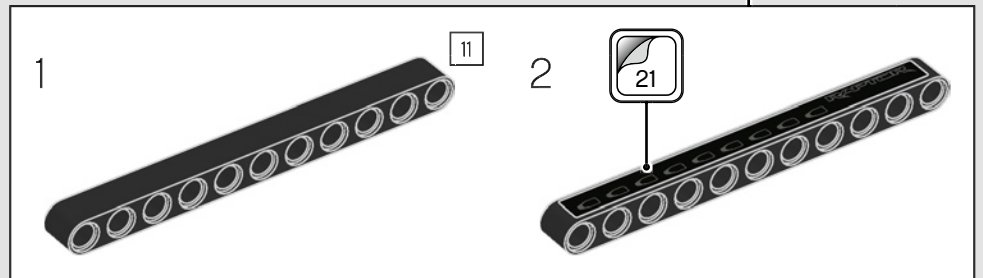
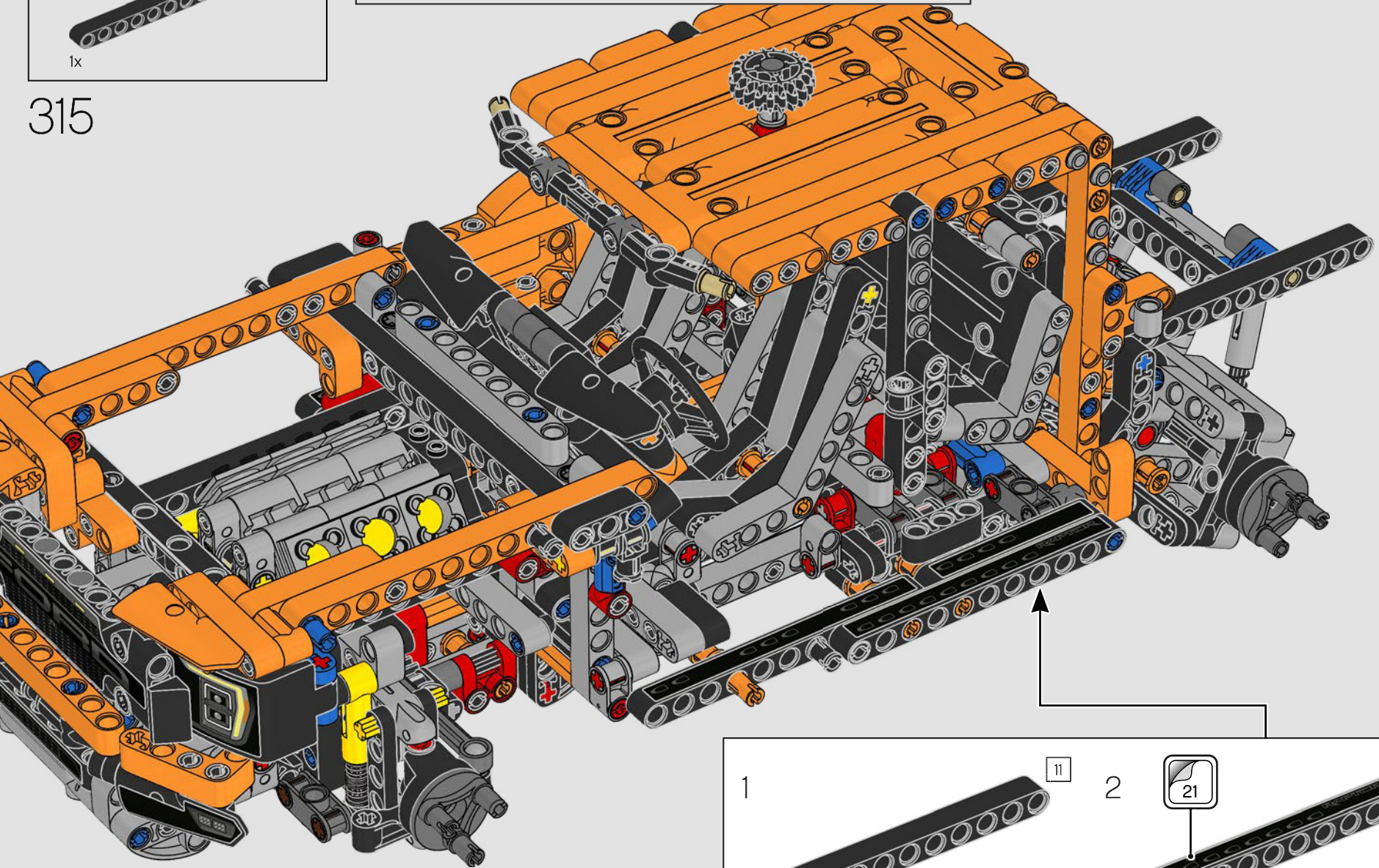

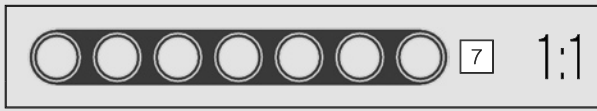
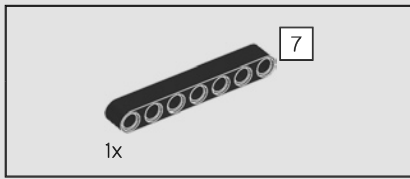

316

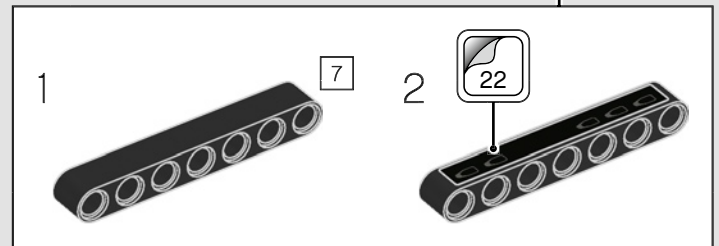
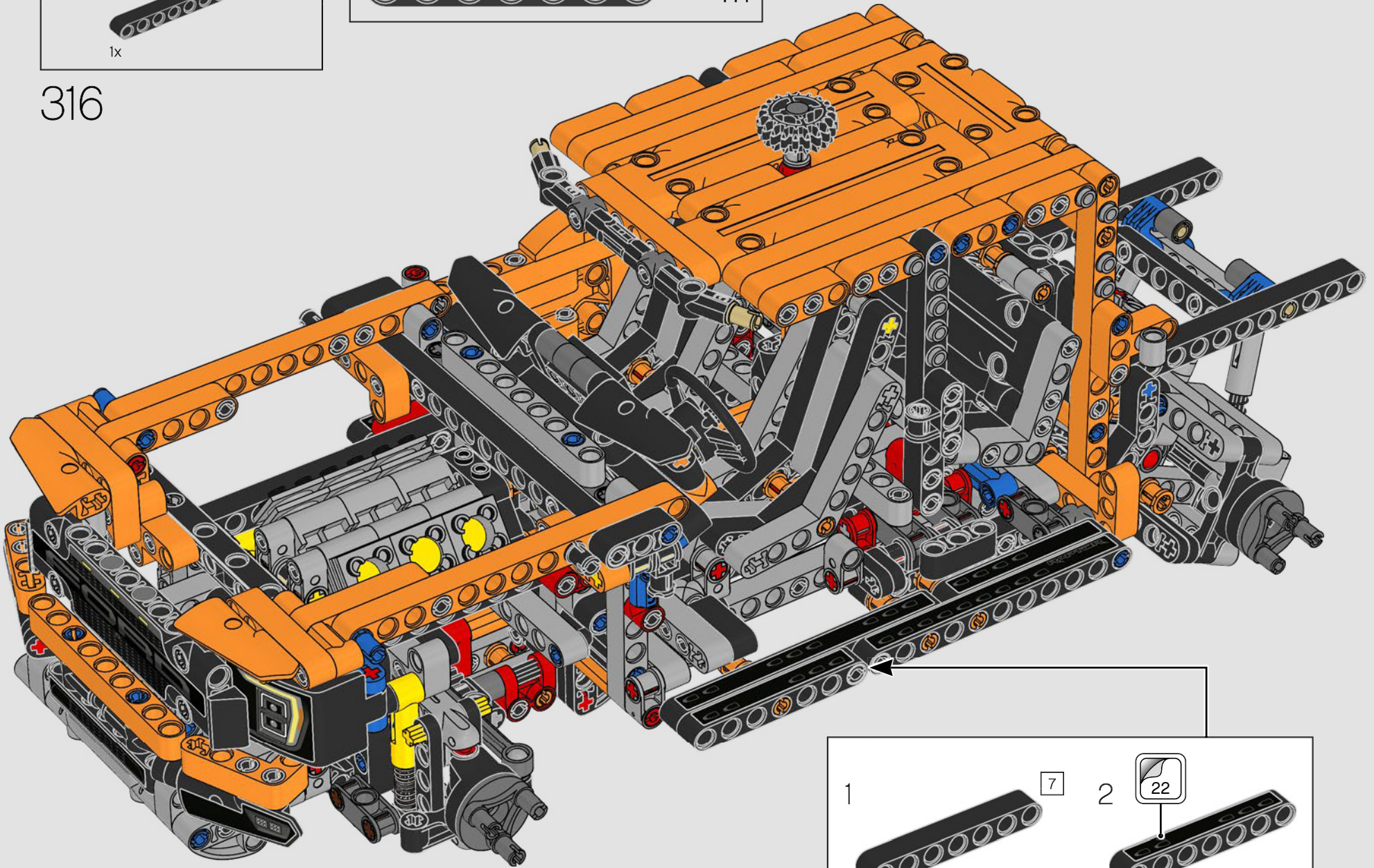

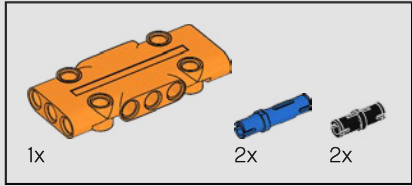
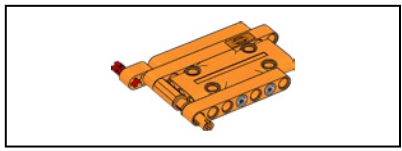

317

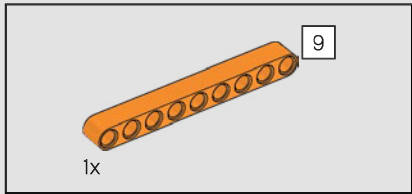
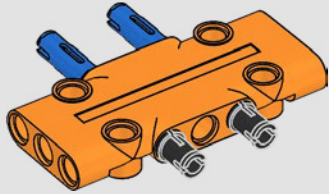

318

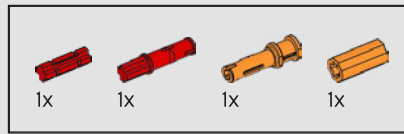
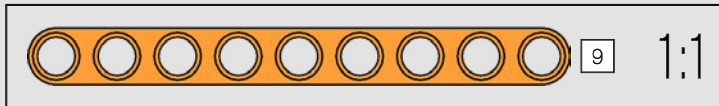
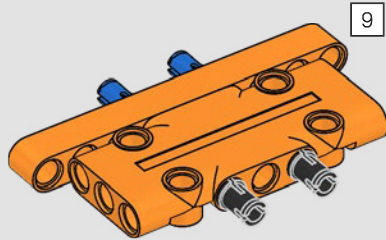

319

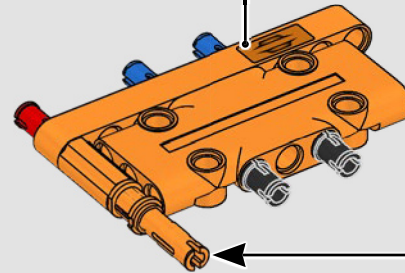
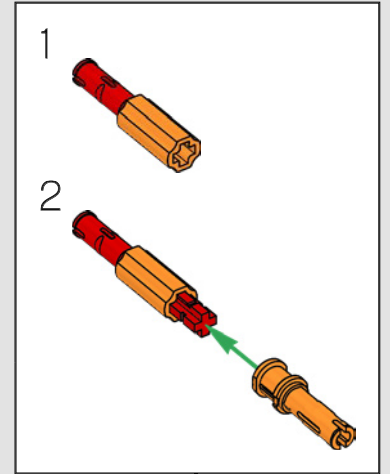

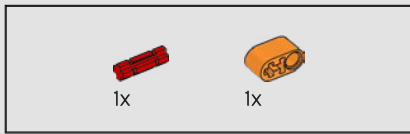

320

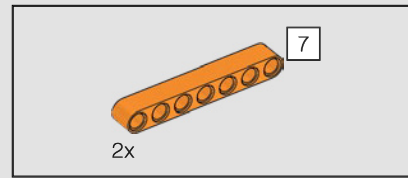
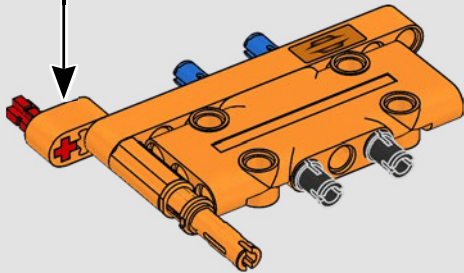

321

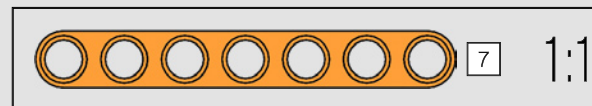
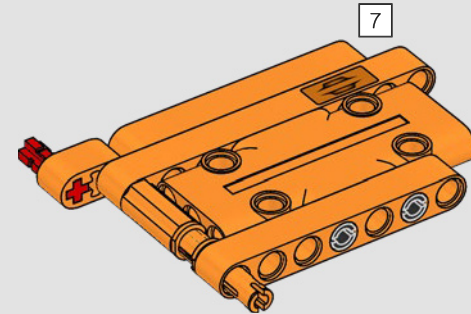

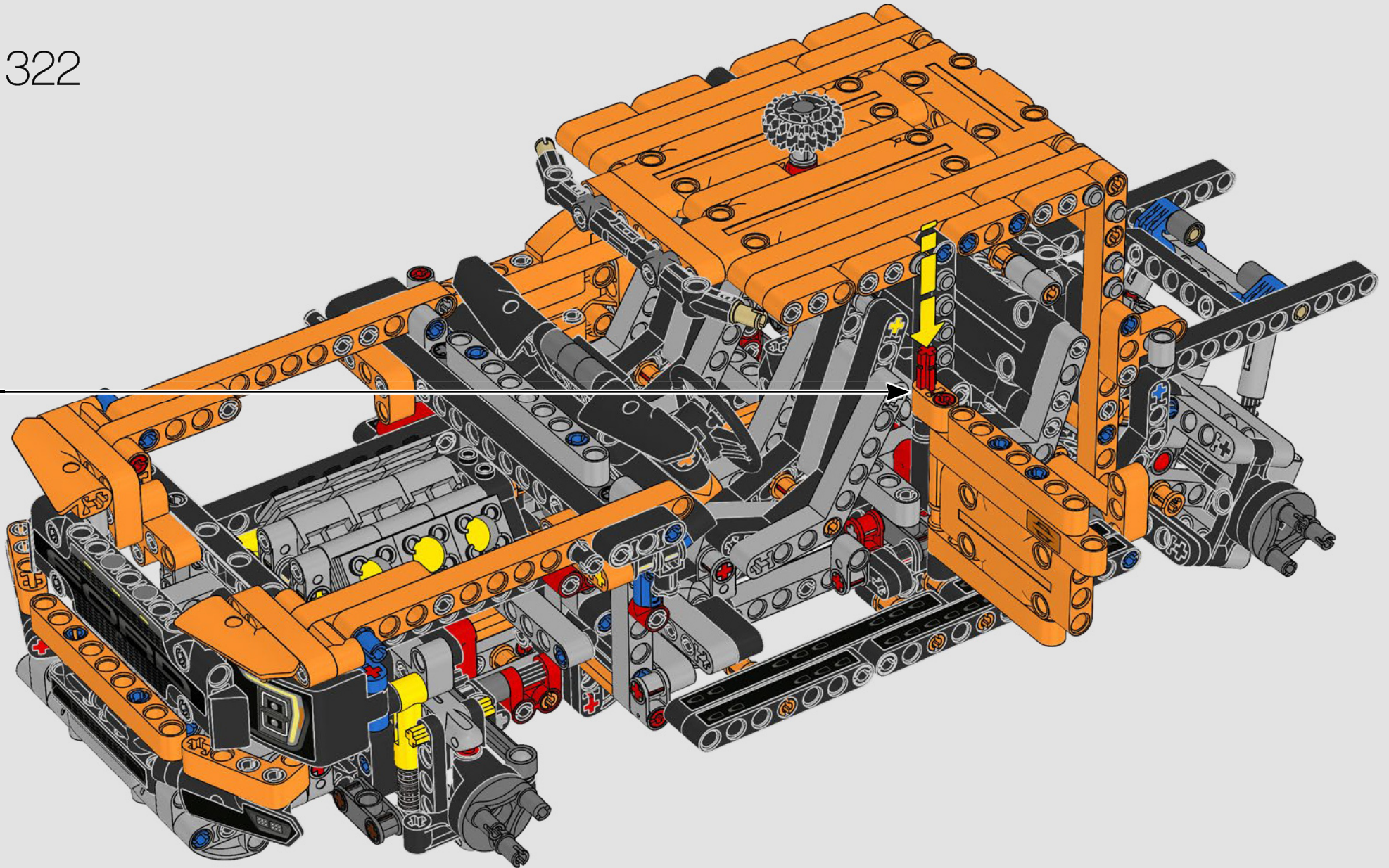

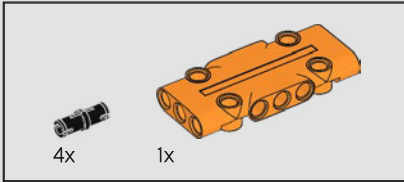
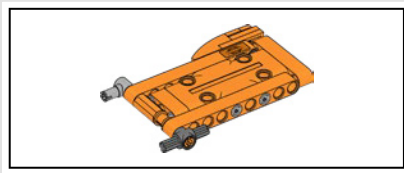

323

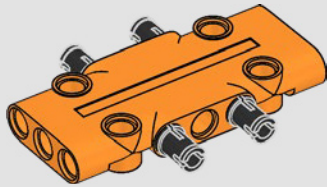

324

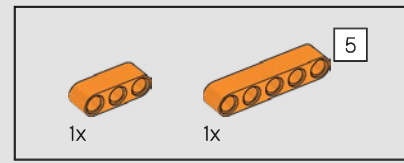
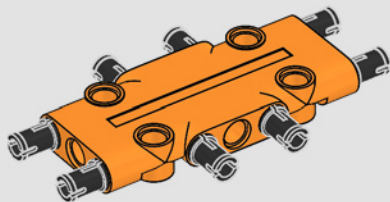

325

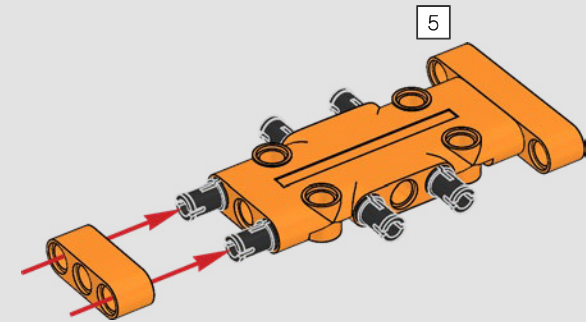
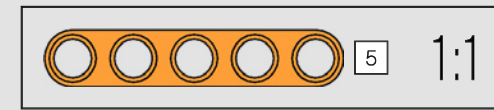

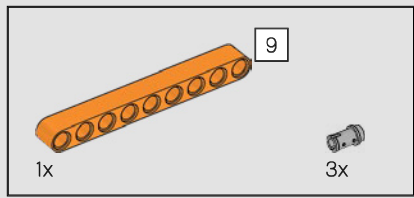

326

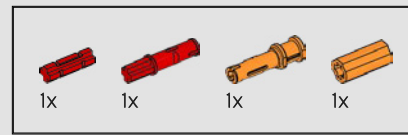
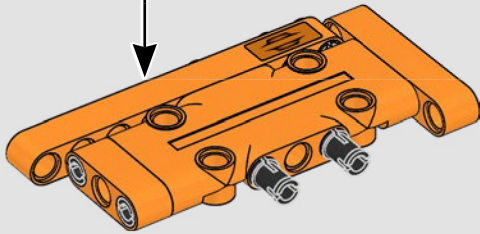
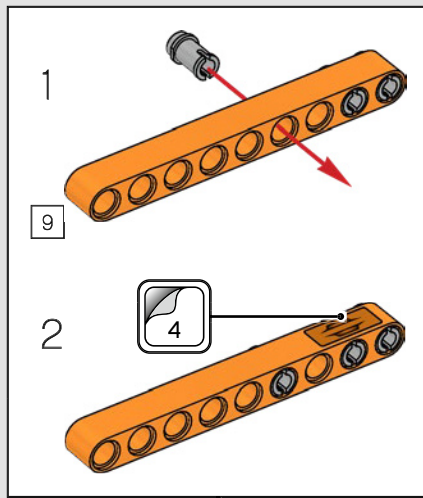

327

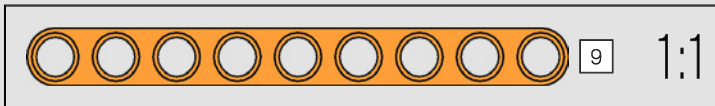
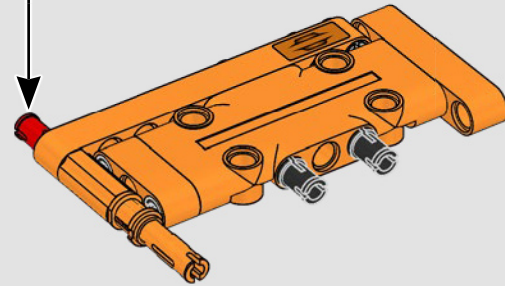
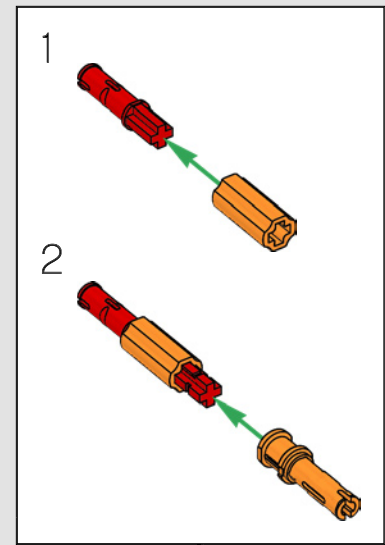

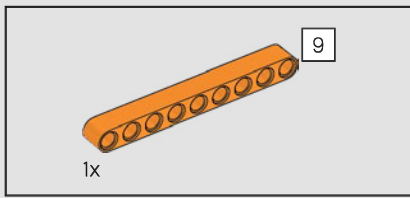

328

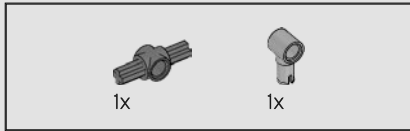
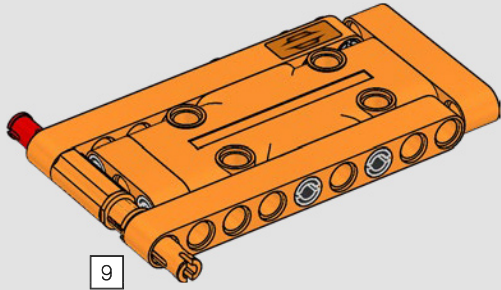

329

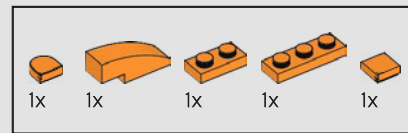
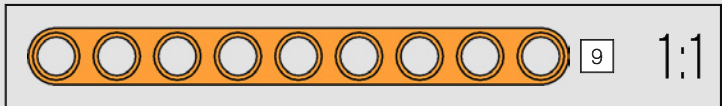
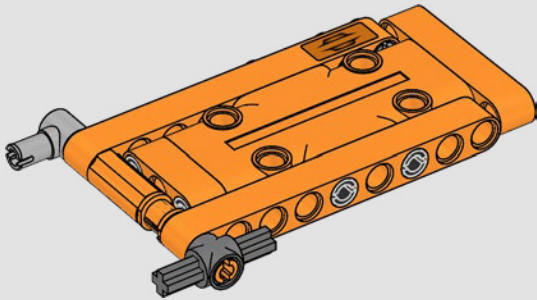

330

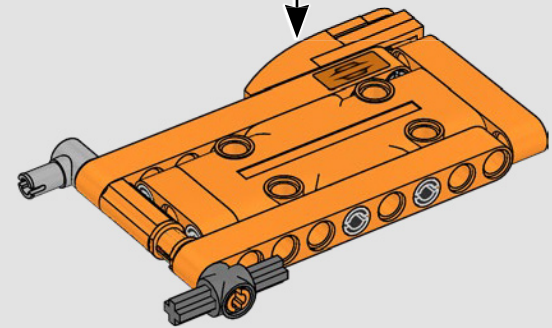
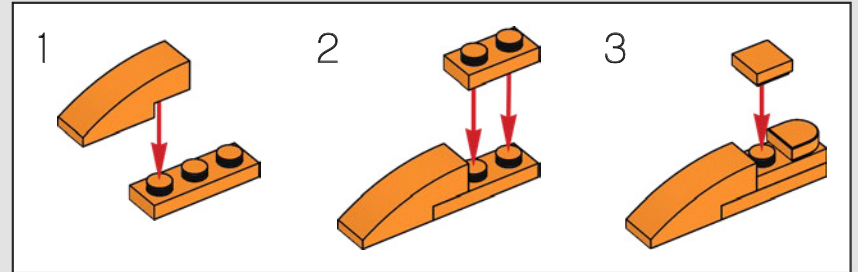

331

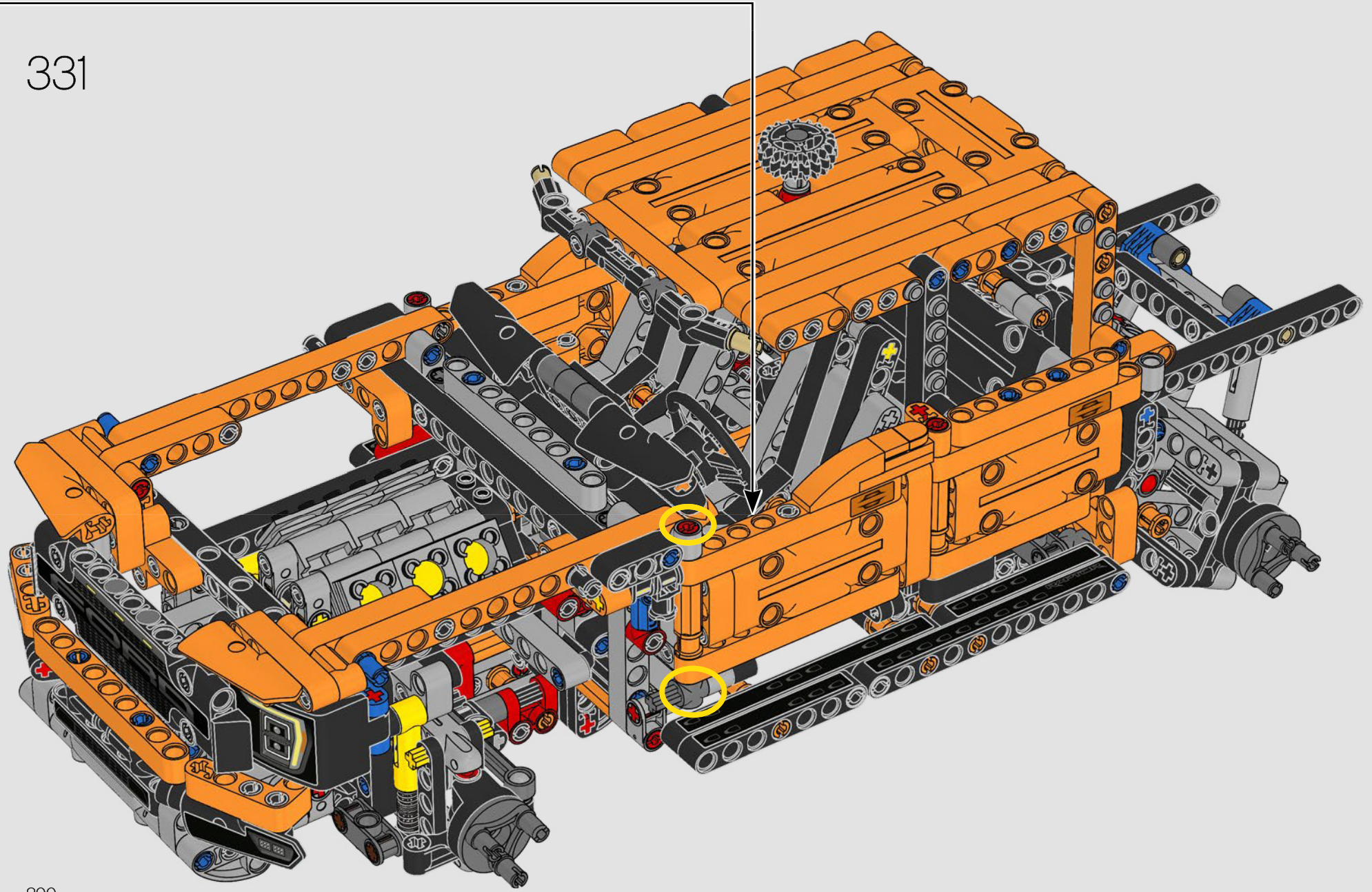

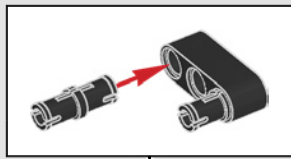
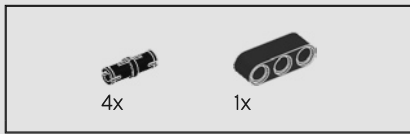

332

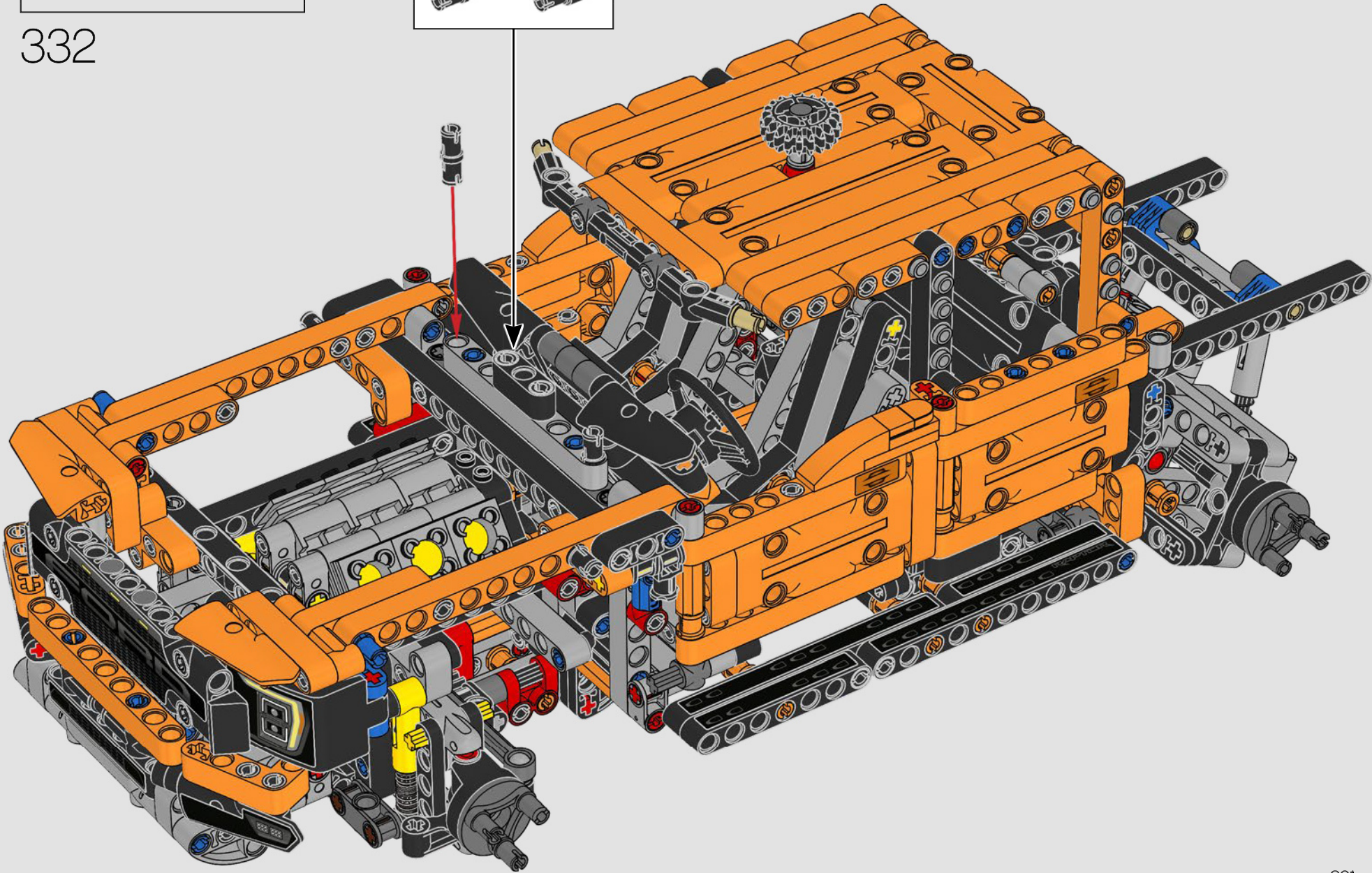

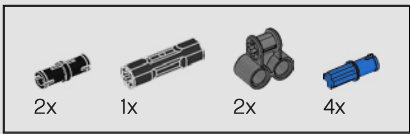

333

1

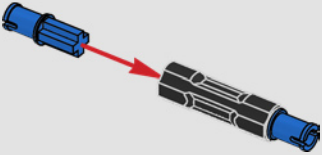

2

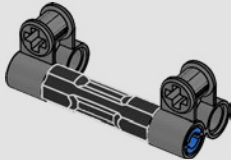

3

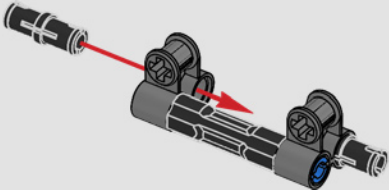

4

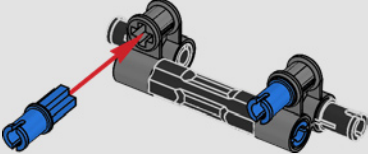

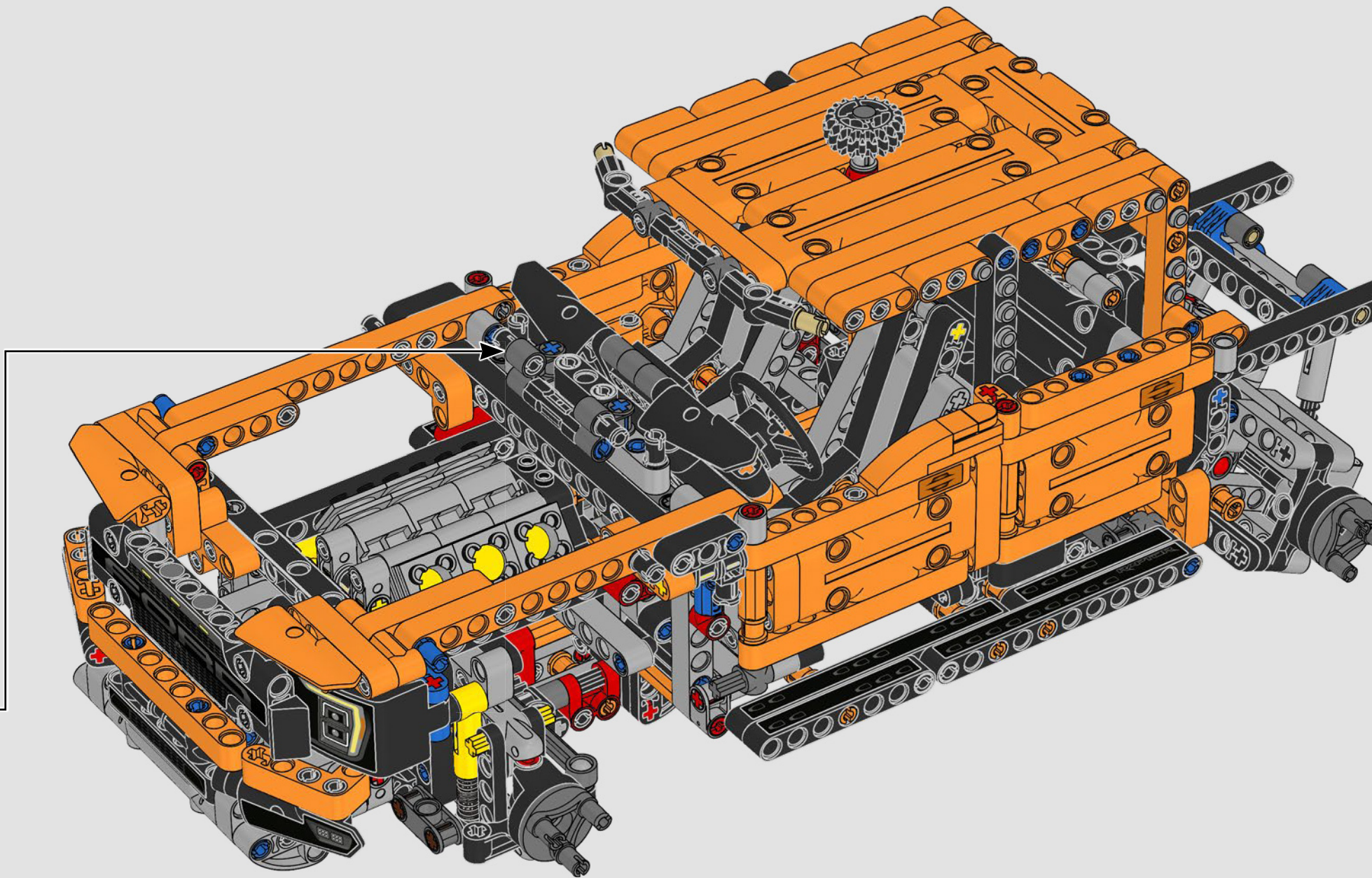

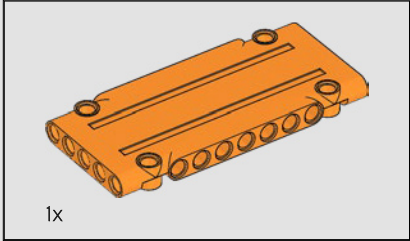
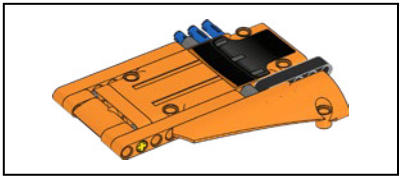

334

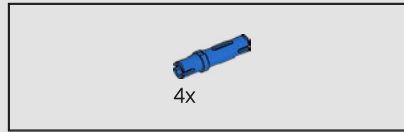
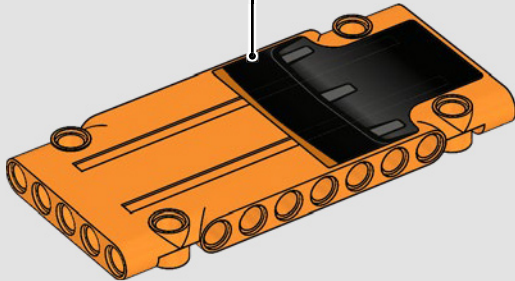

335

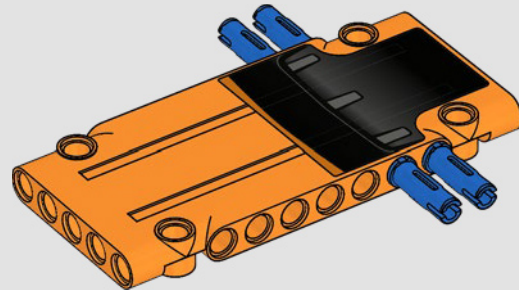

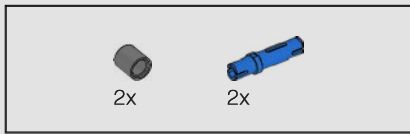

336

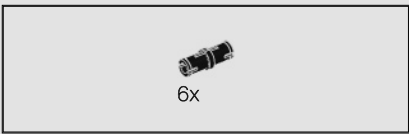
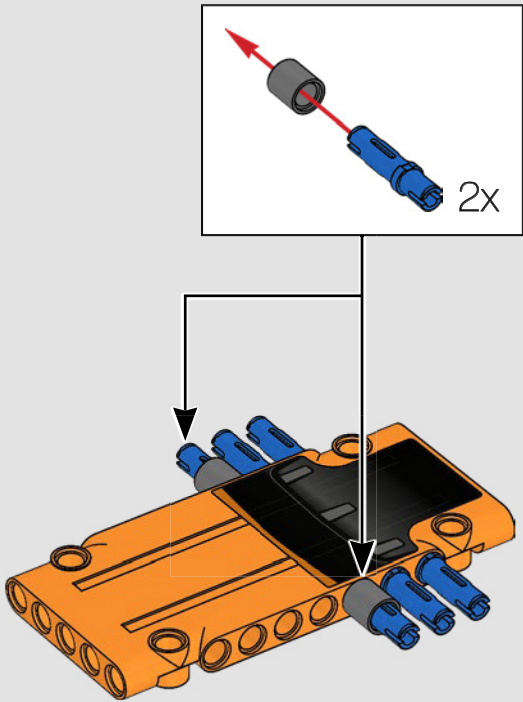

337

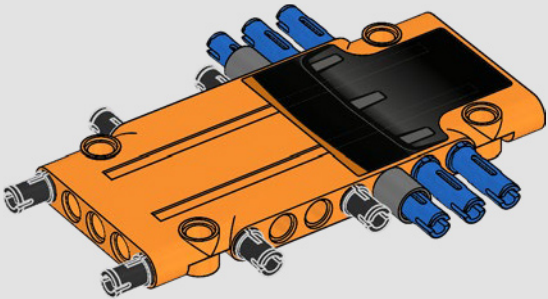

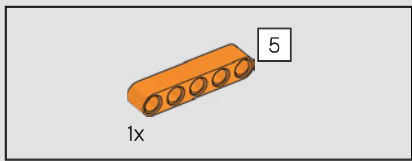

338

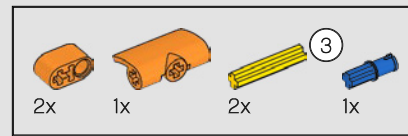
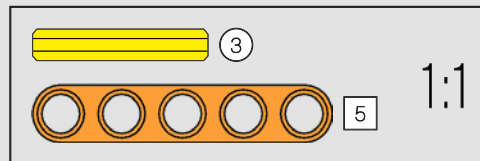
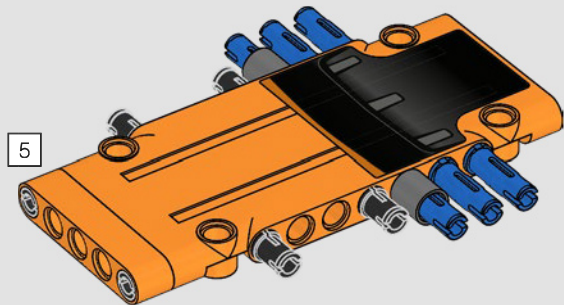

339

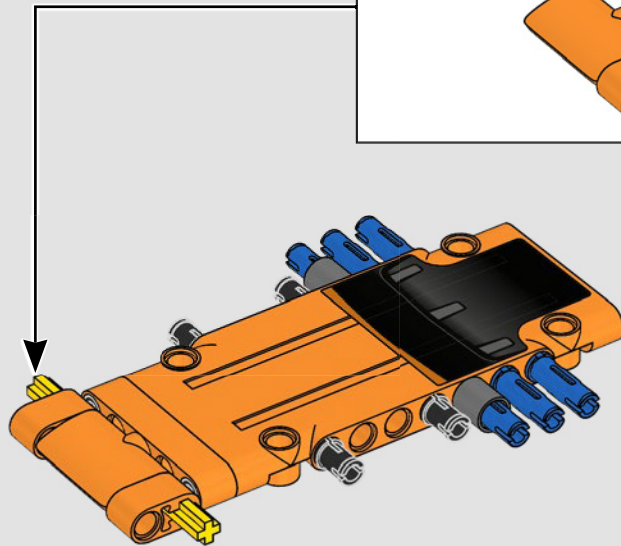
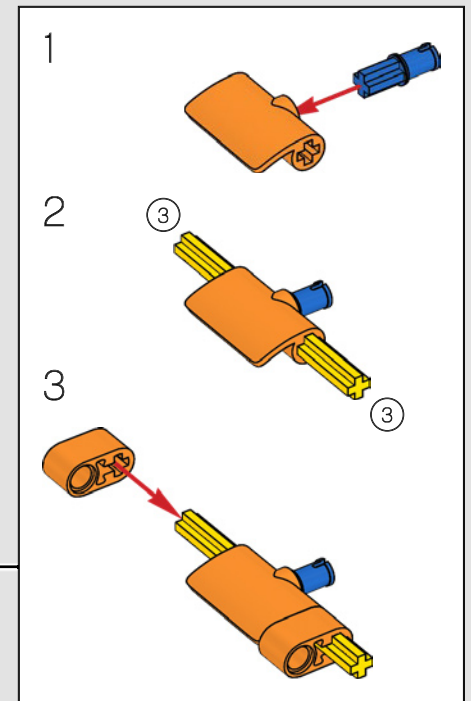

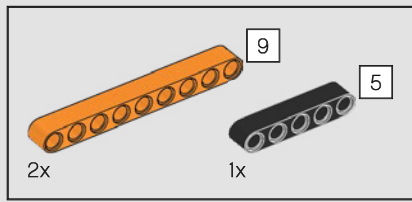

340

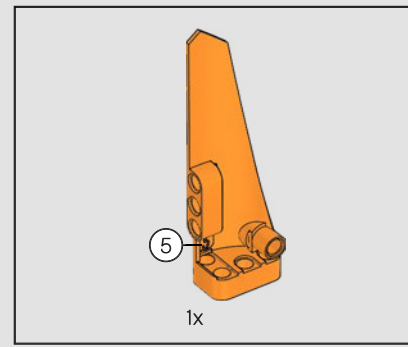
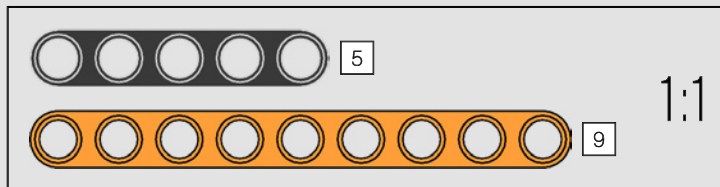
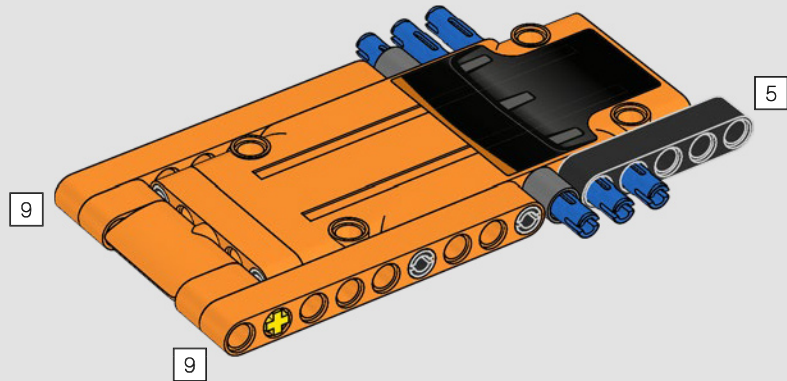

341

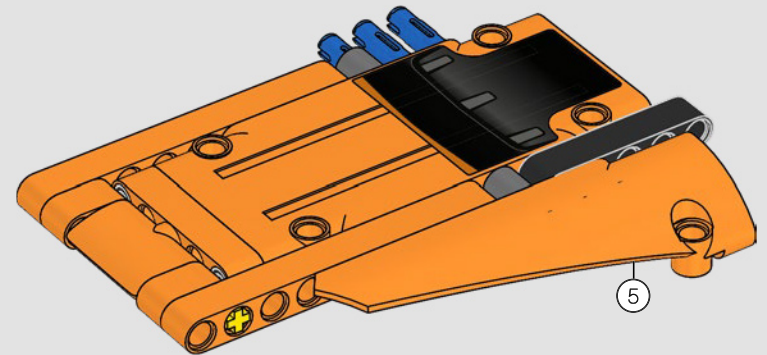

342

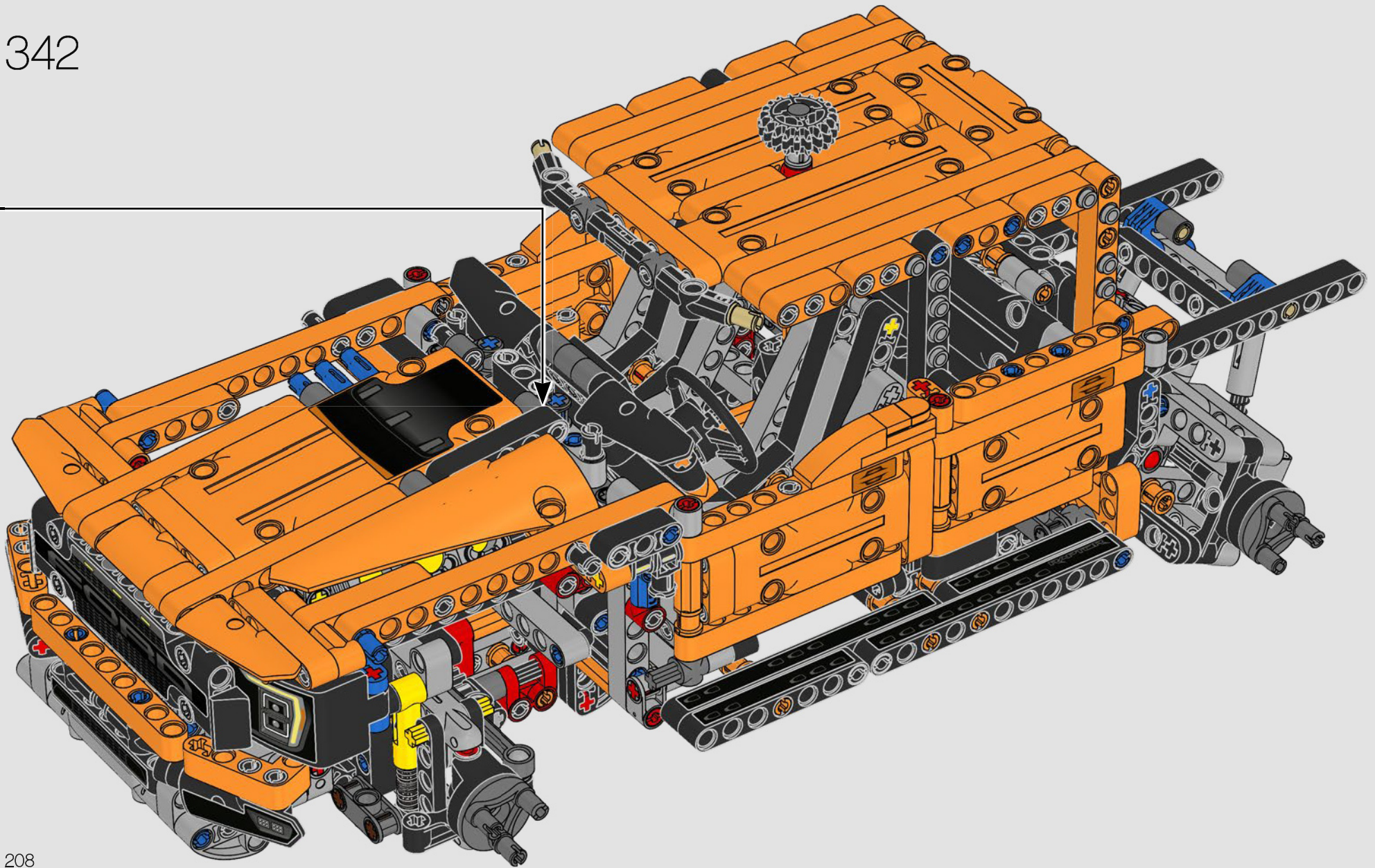

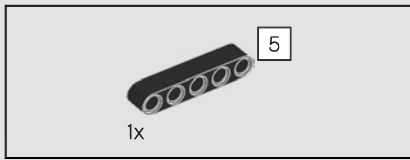

343

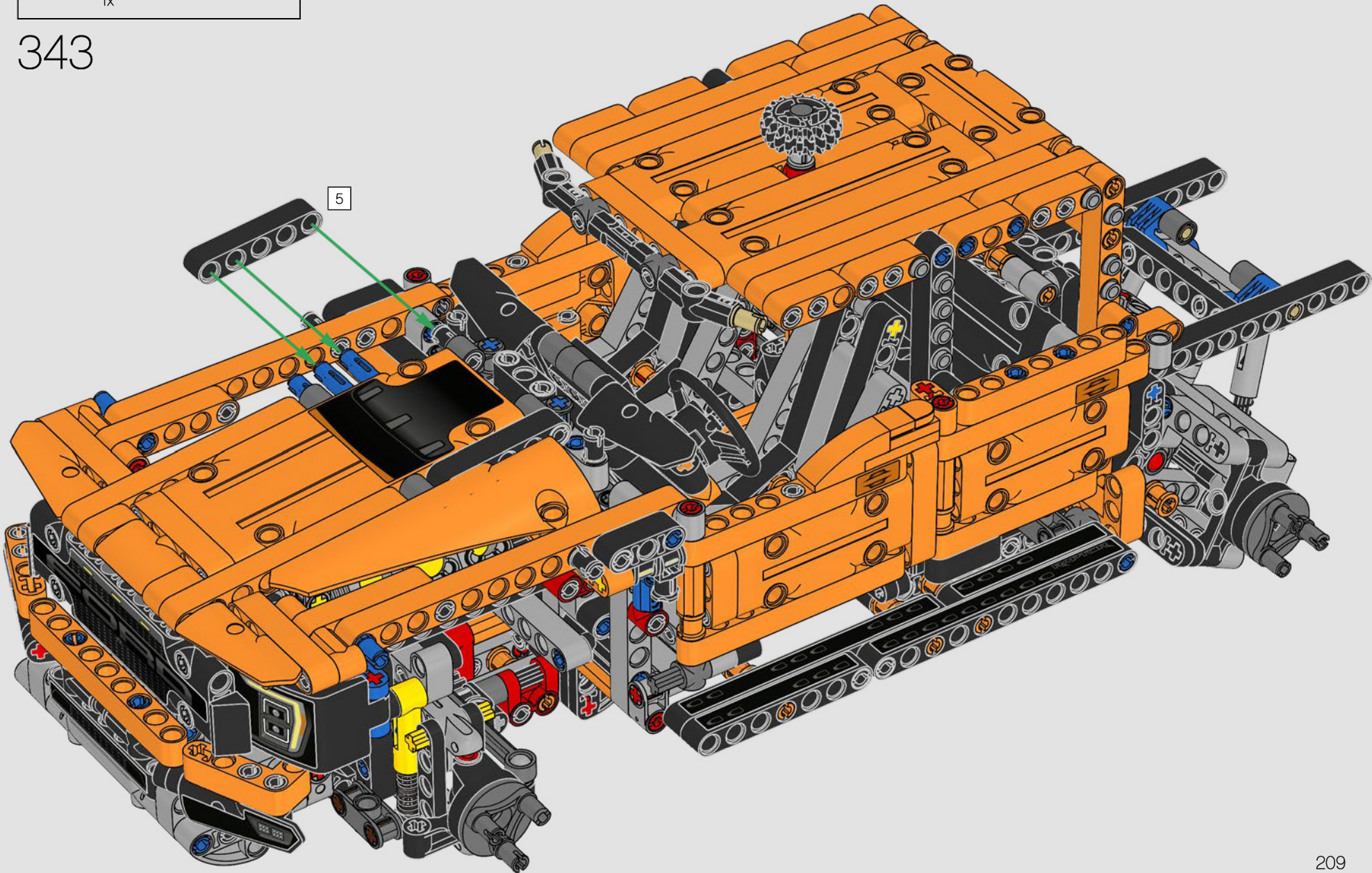

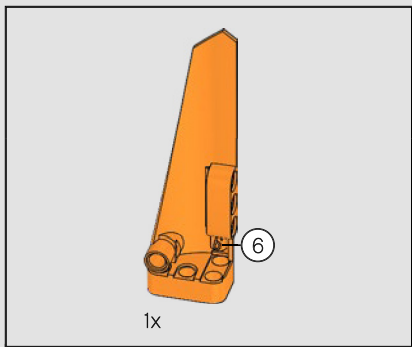

344

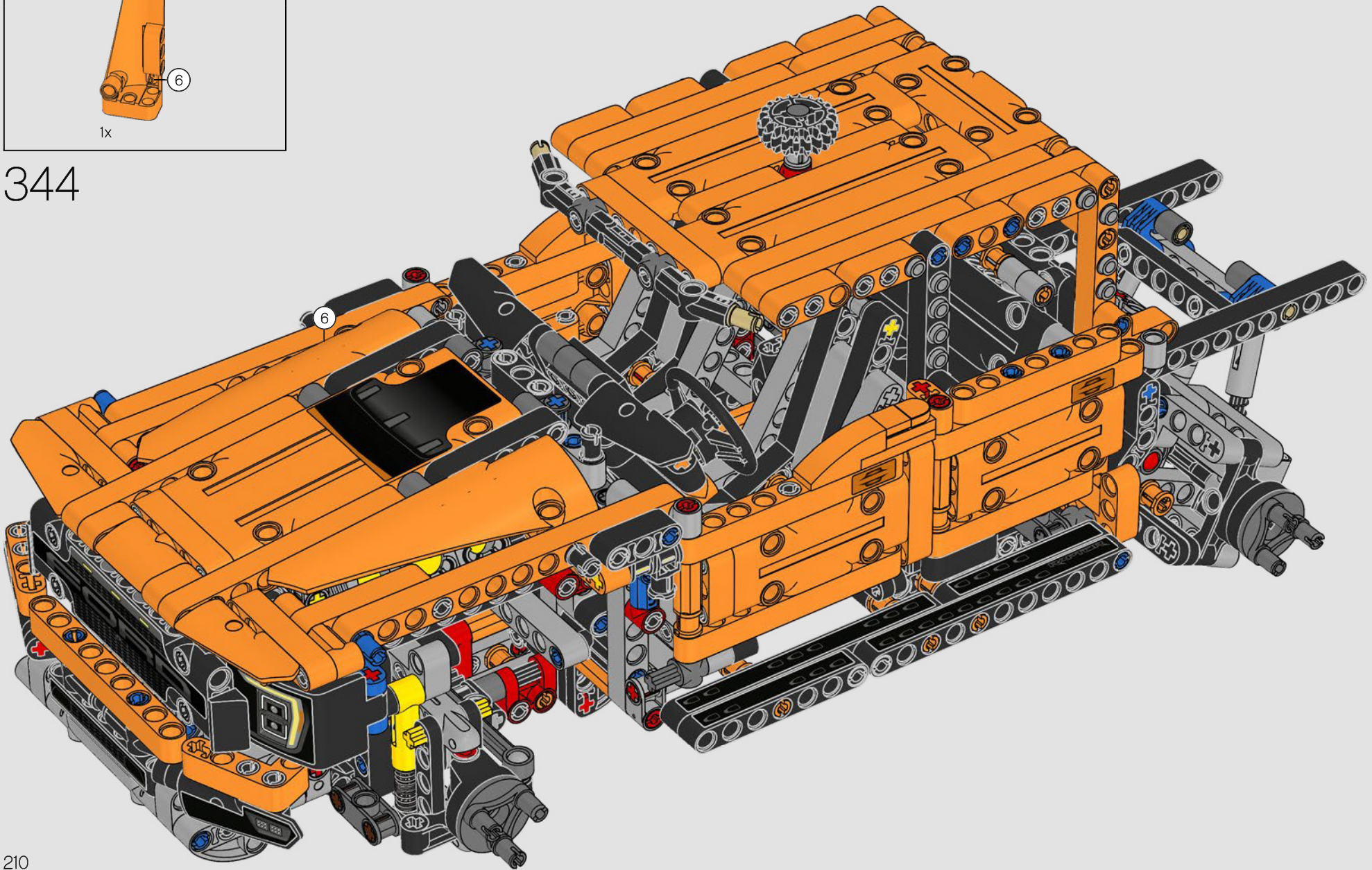



345

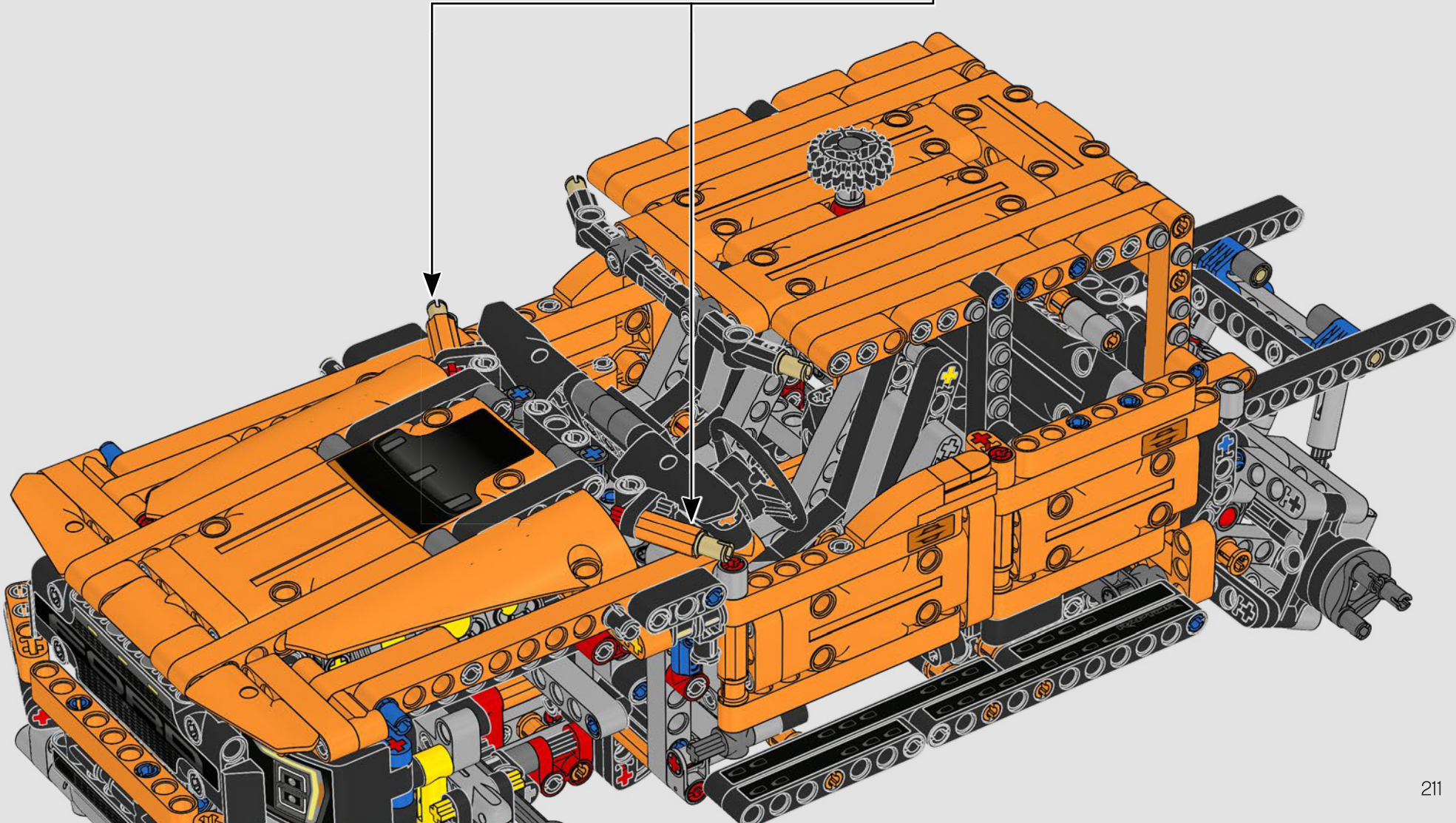
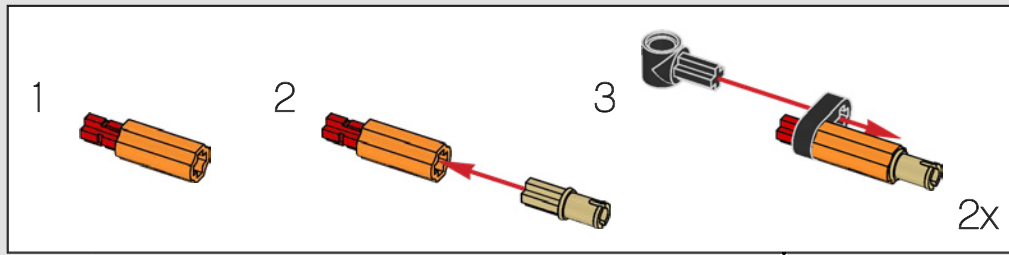

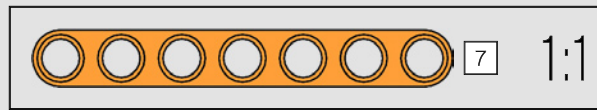
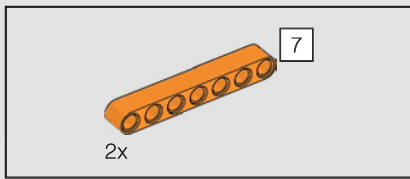

346

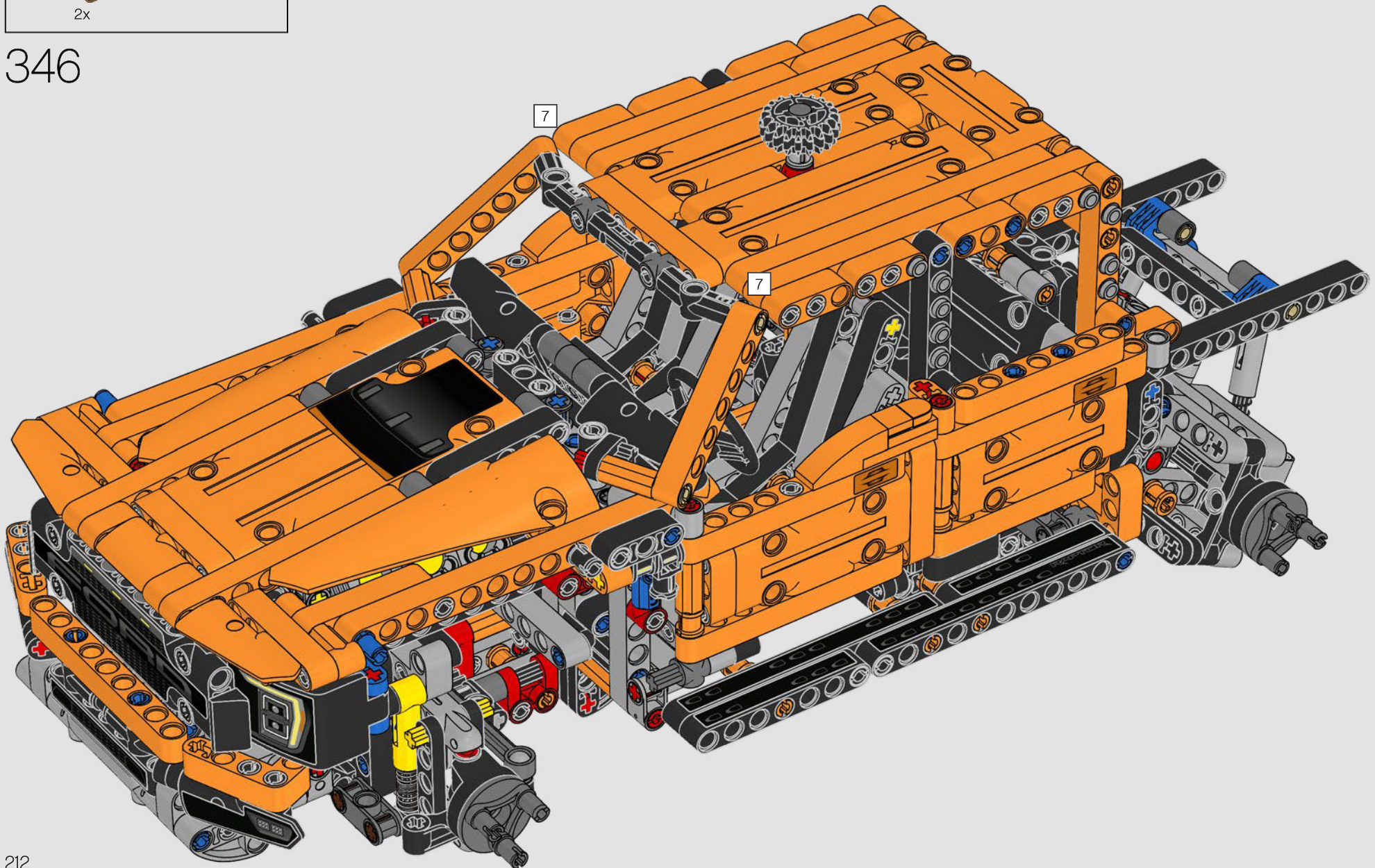

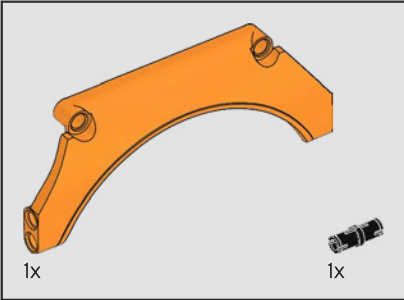
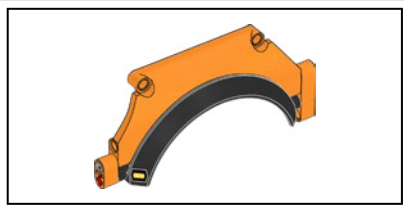

347

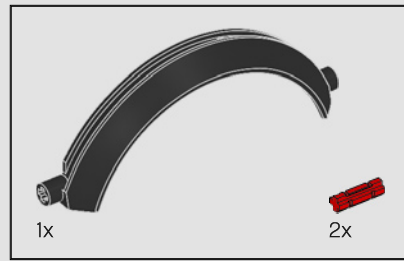
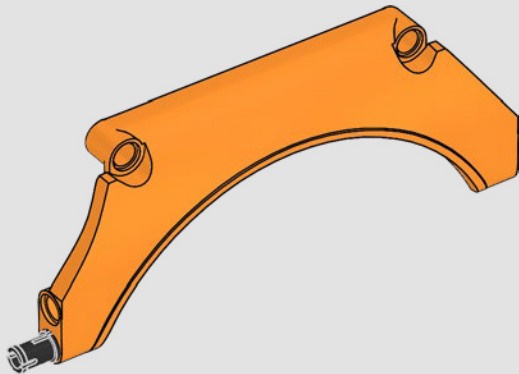

348

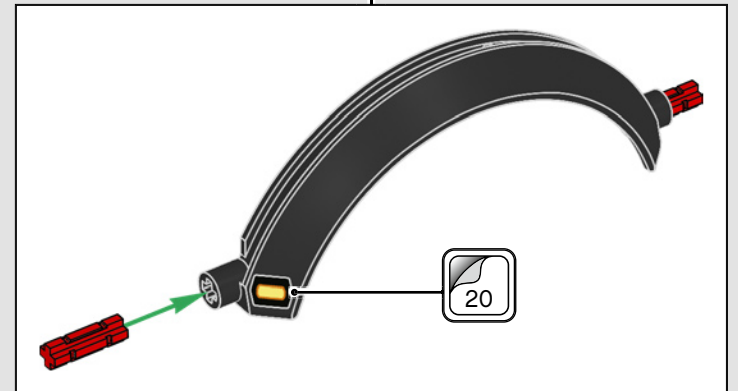
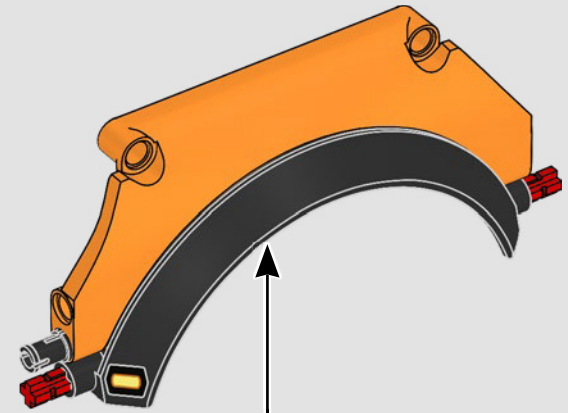

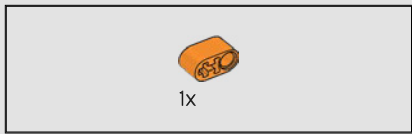

349

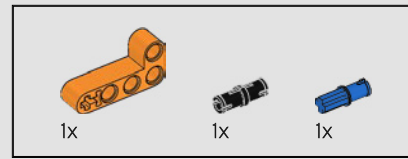
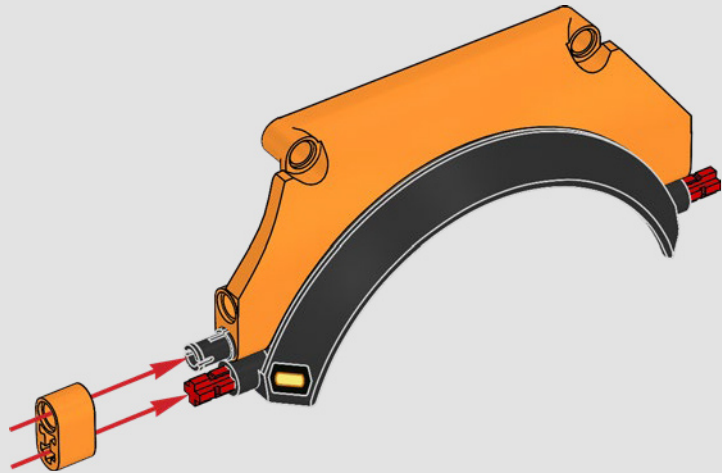

350

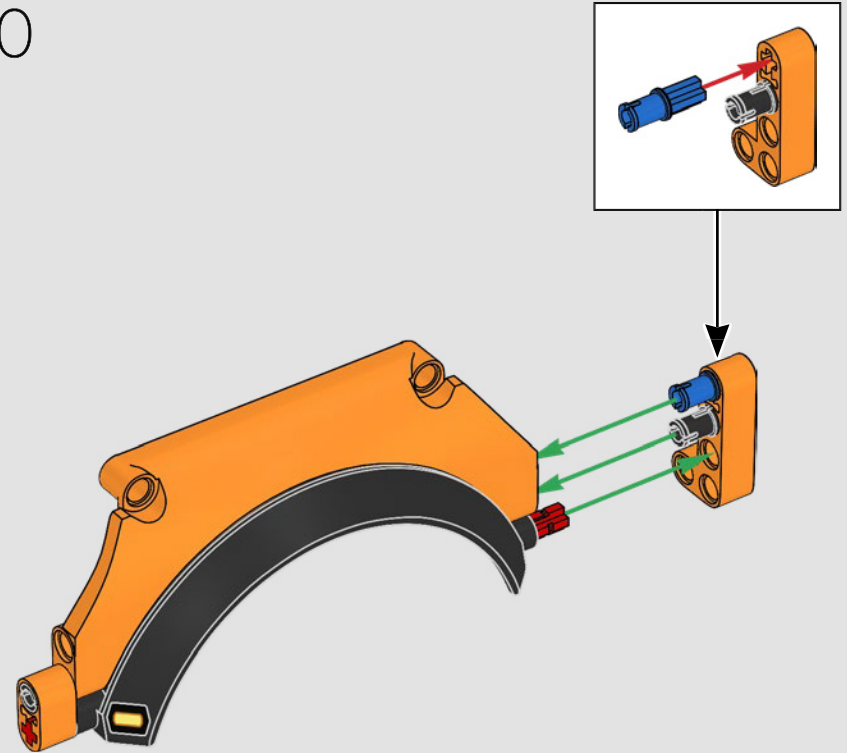

351

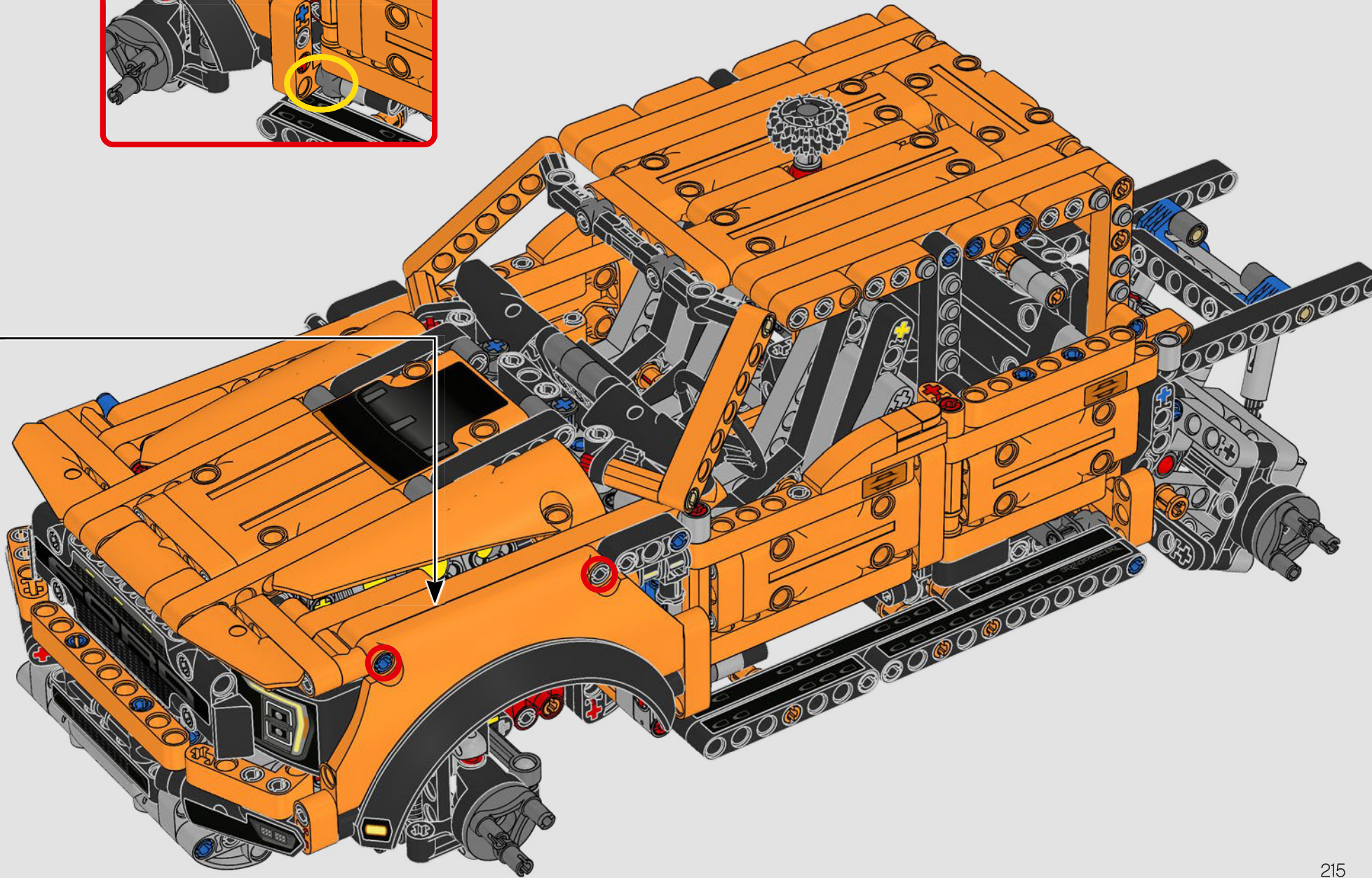
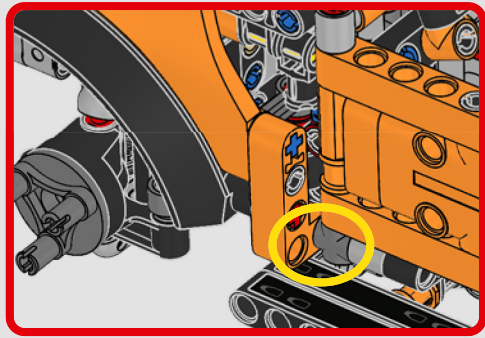

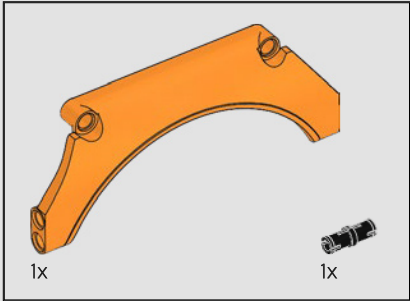
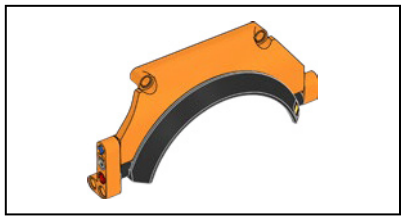

352

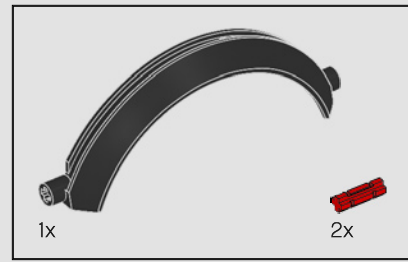
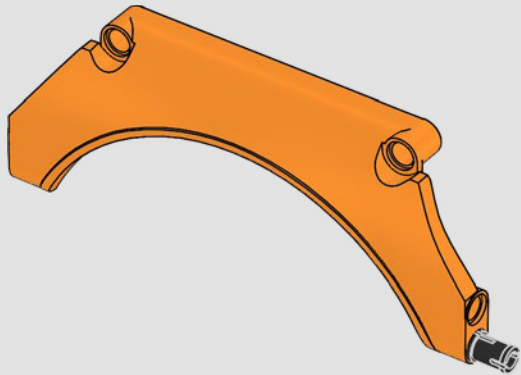

353

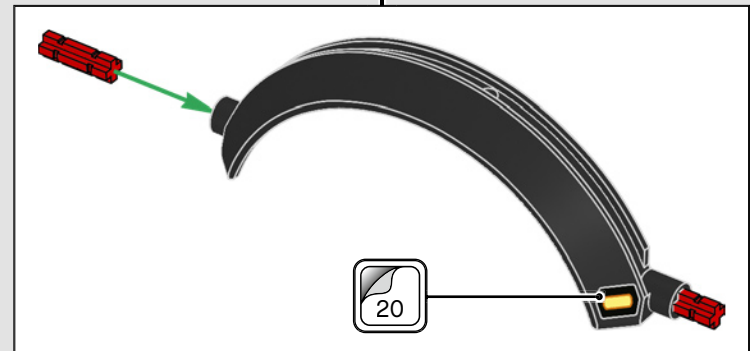
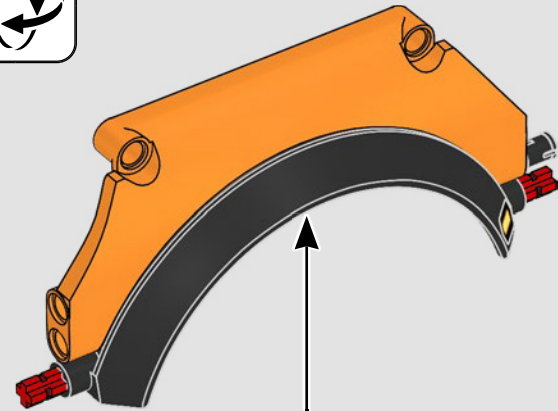
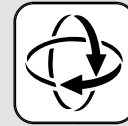

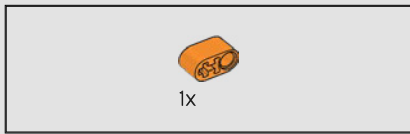

354

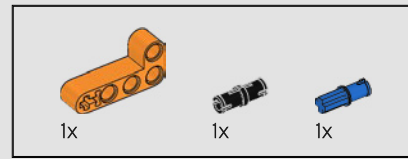
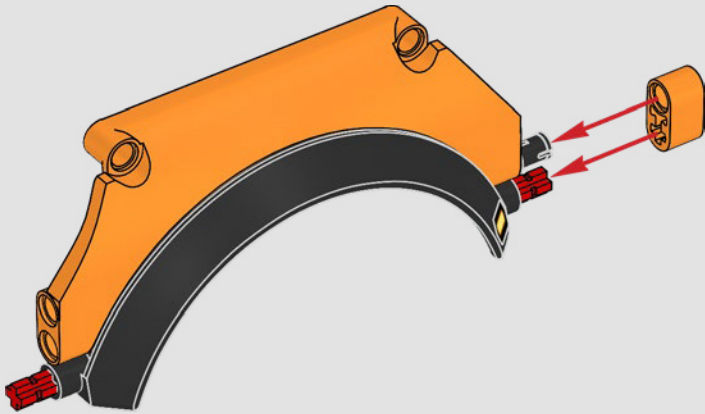

355

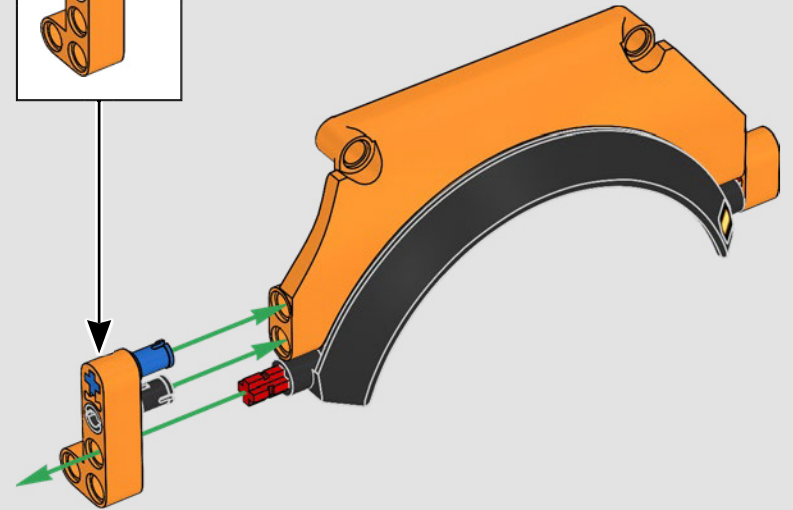
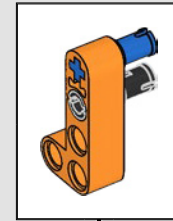

356

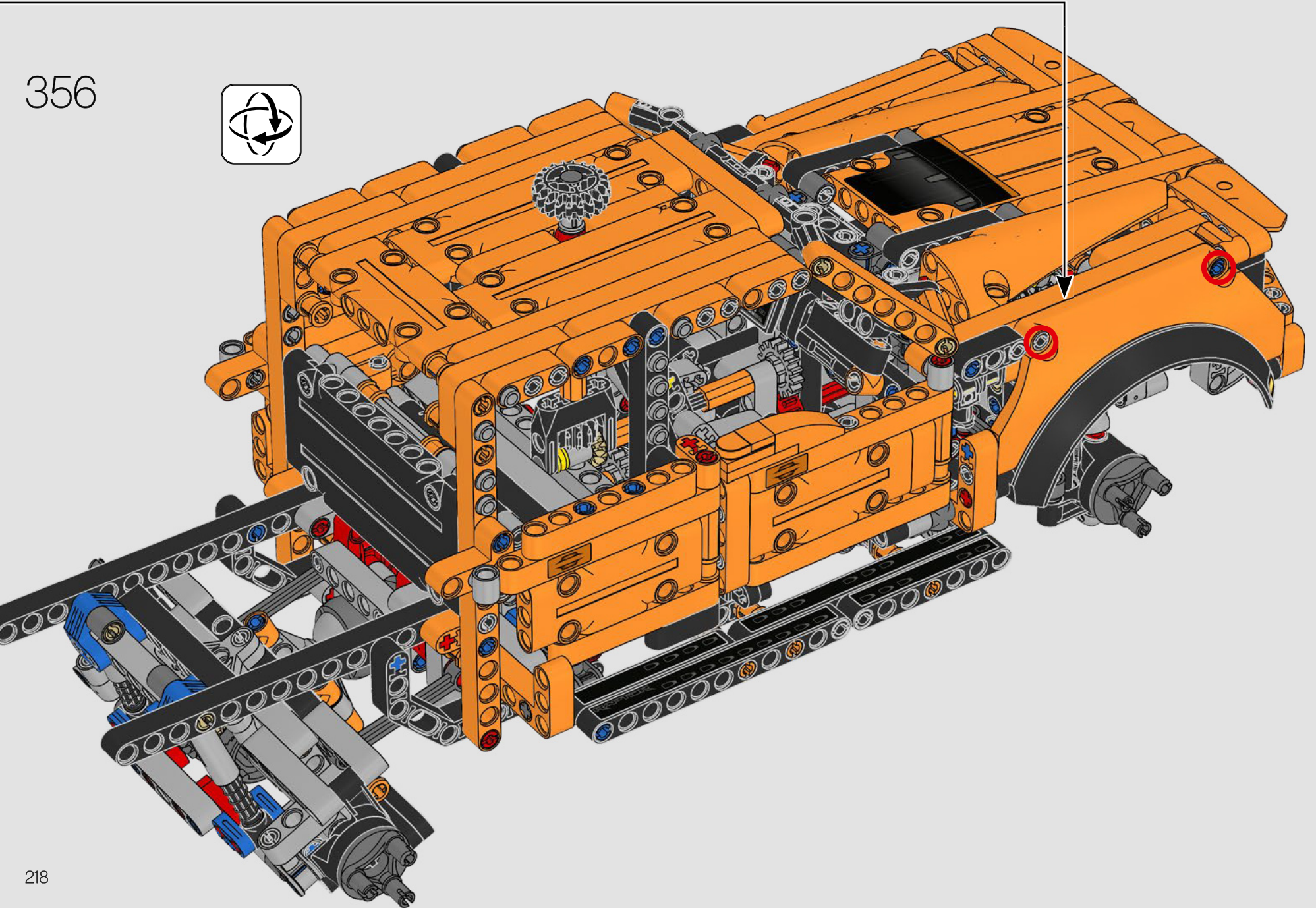



357

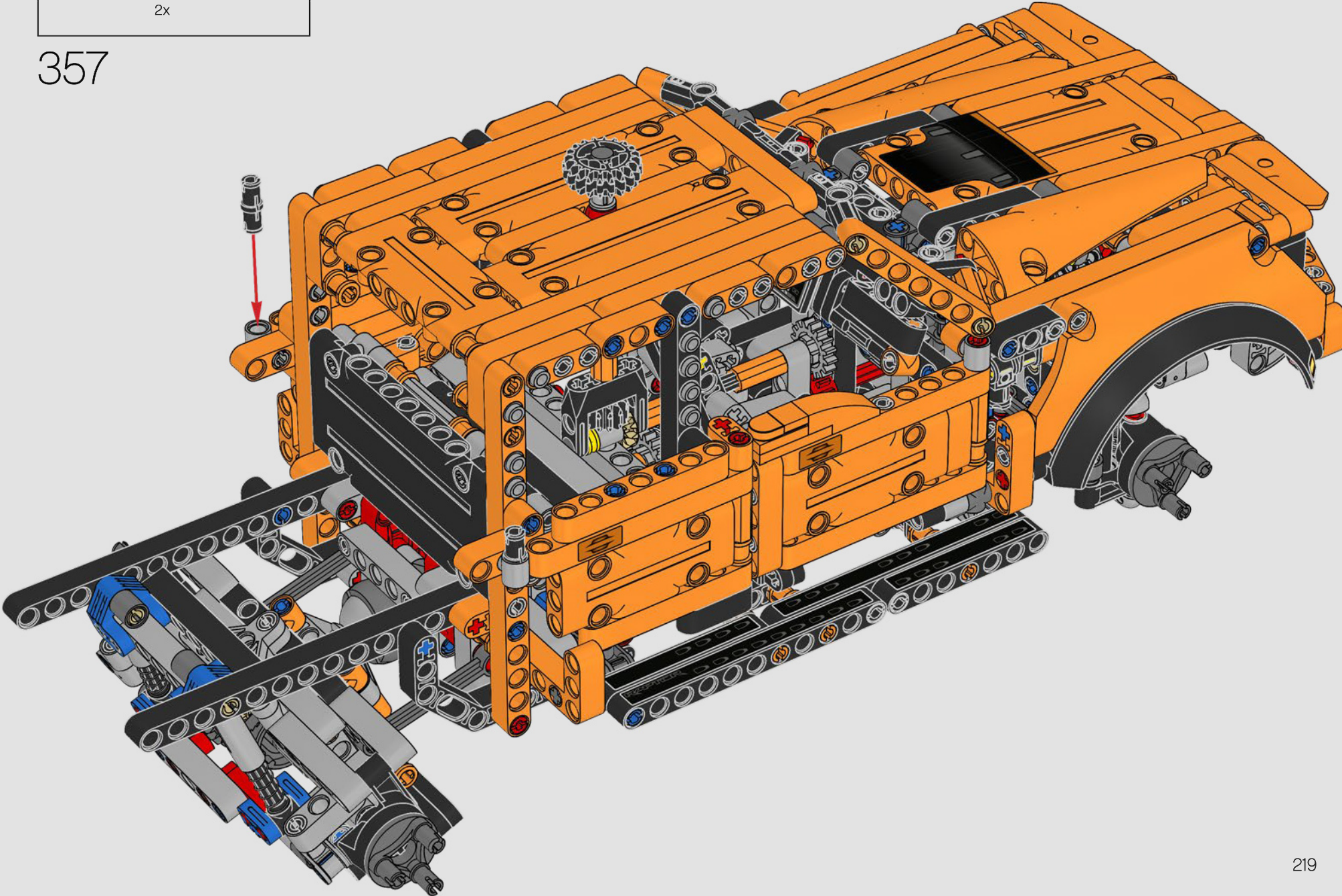

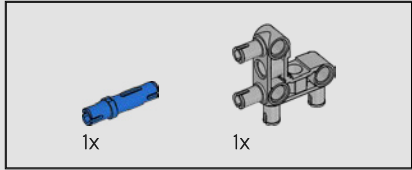
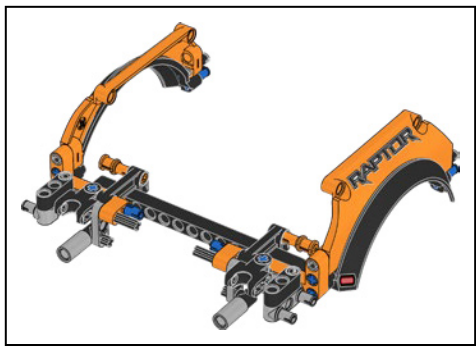

358

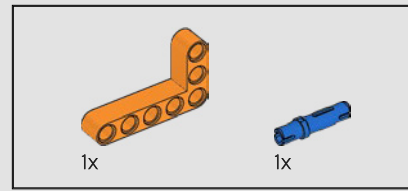
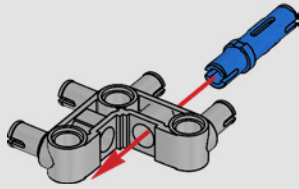

359

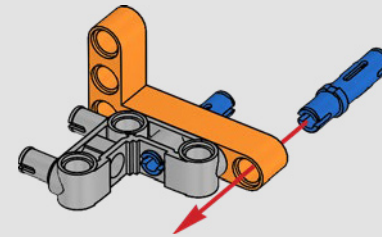

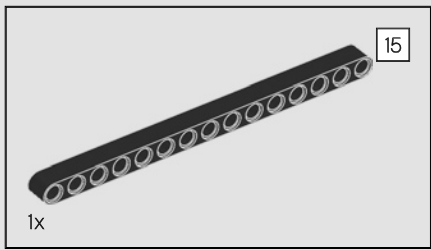

360

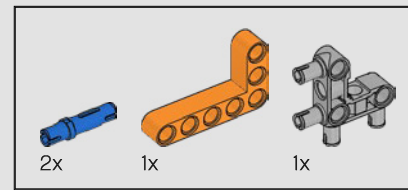
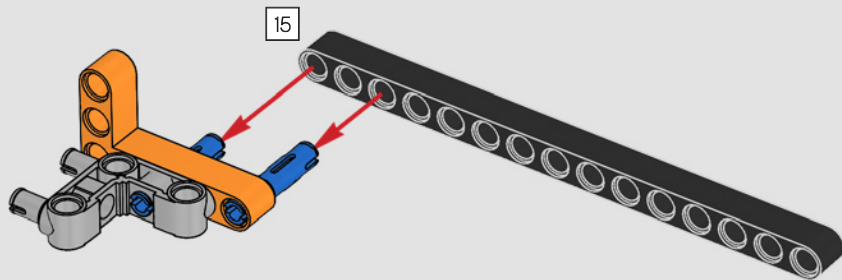

361

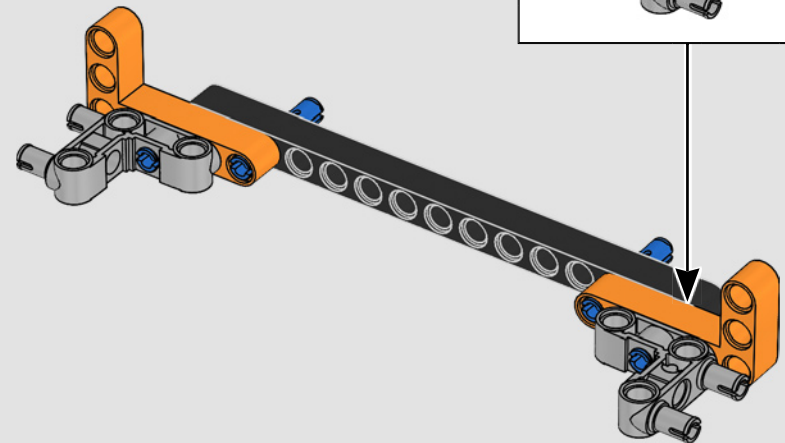
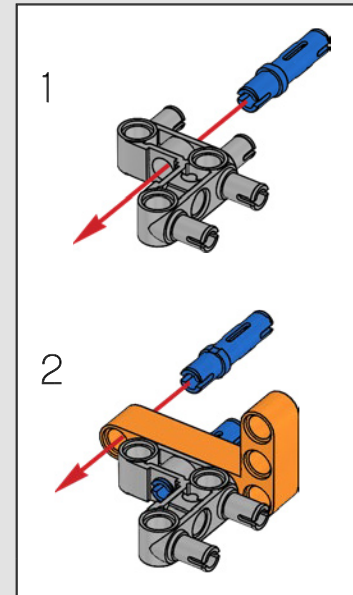

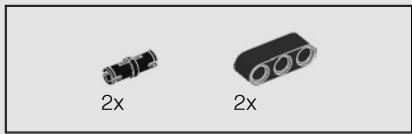

362

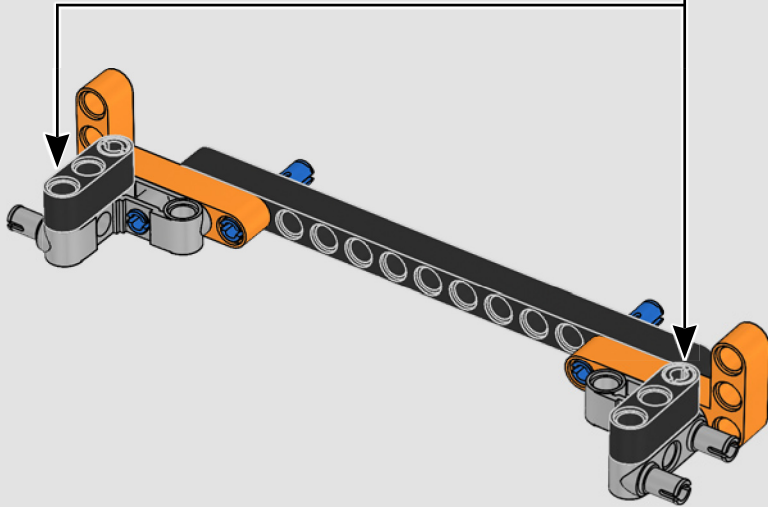
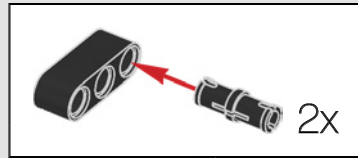

363

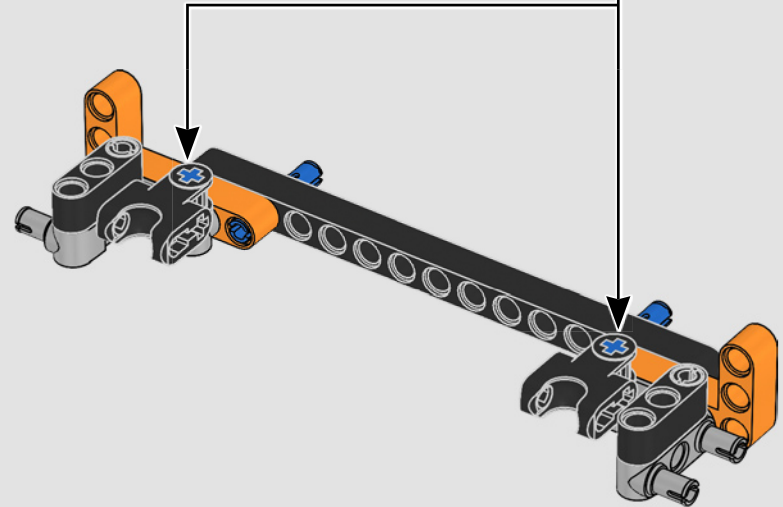
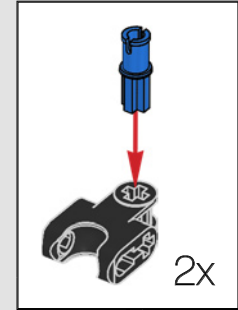

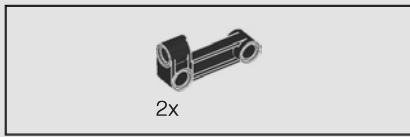

364

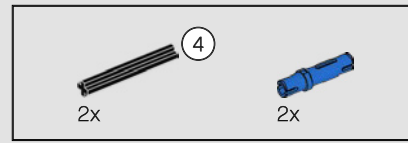
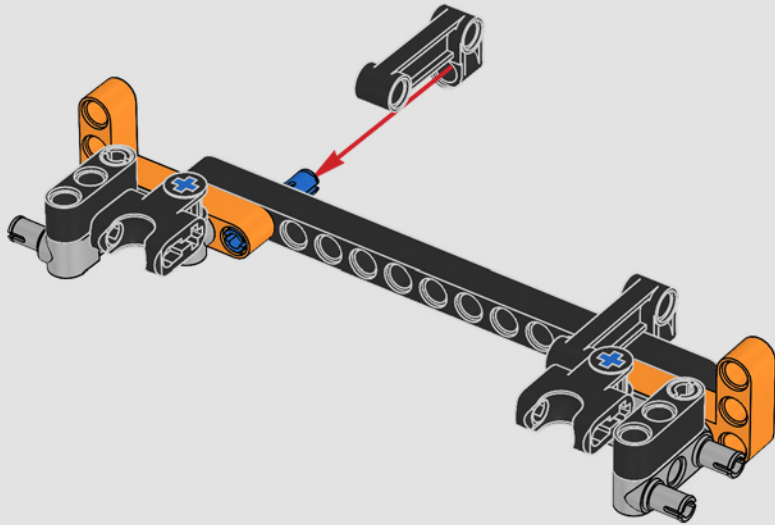

365

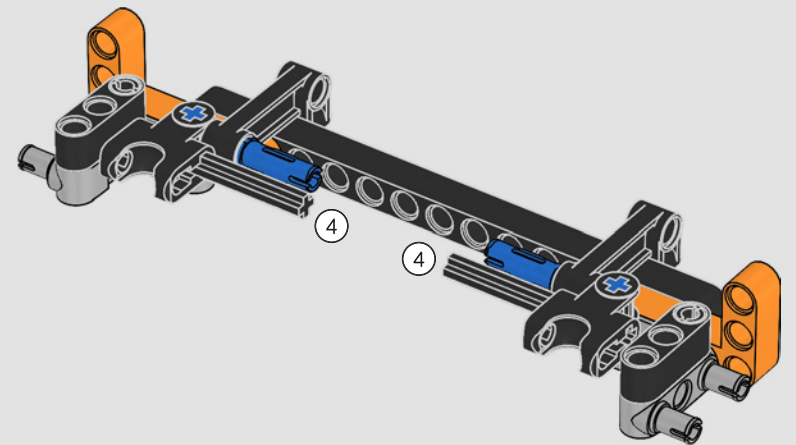
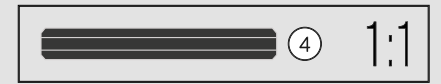

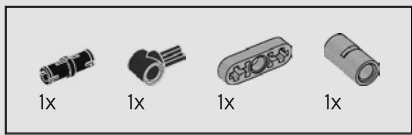

366

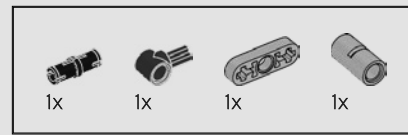
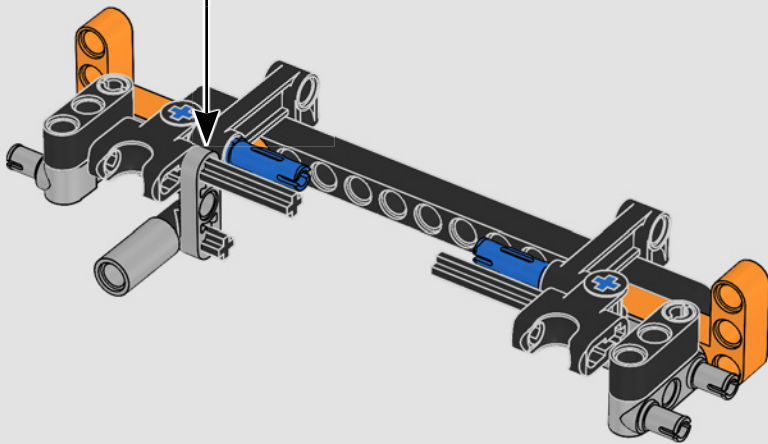
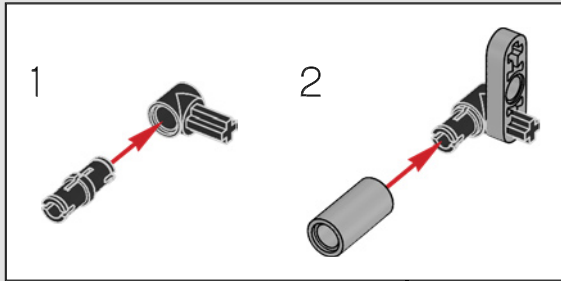

367

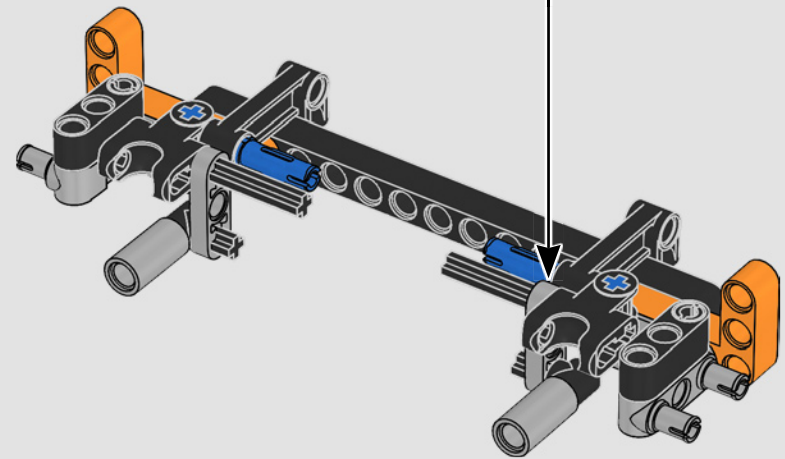
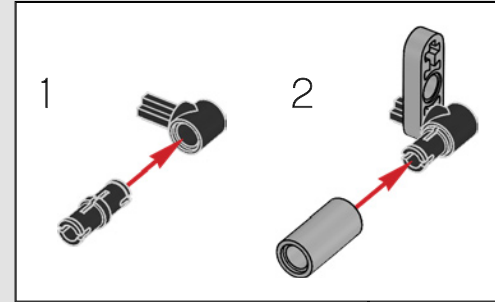



368

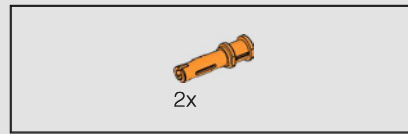
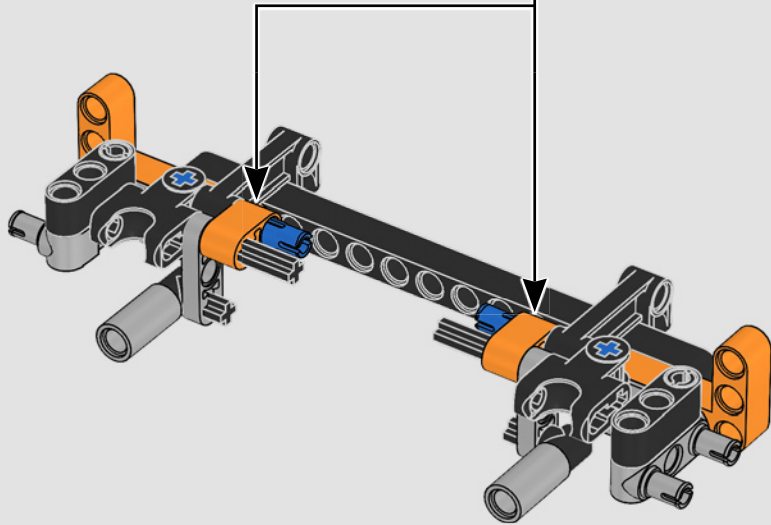
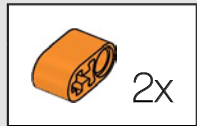

369

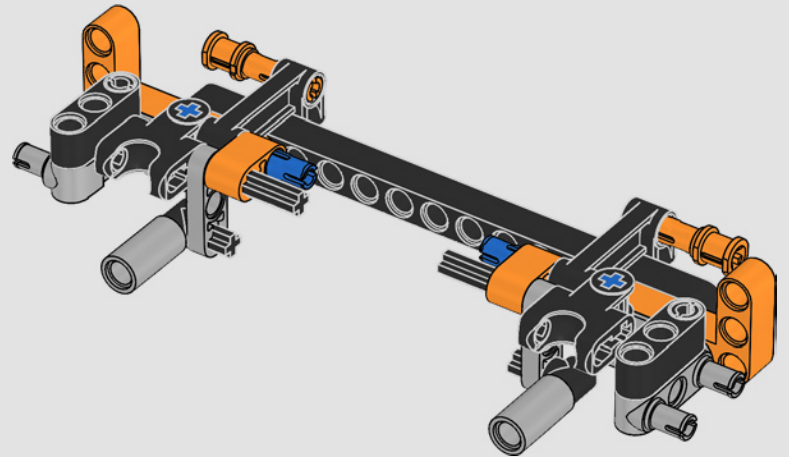

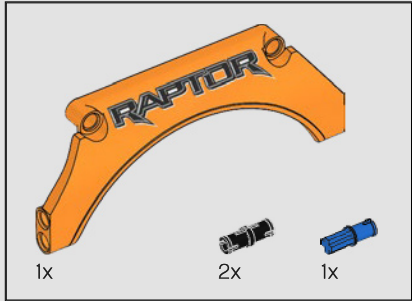

370

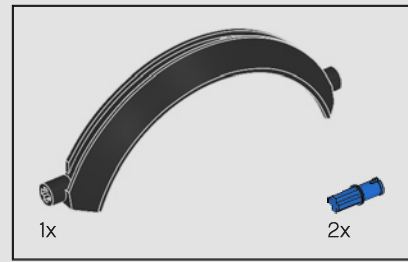

371

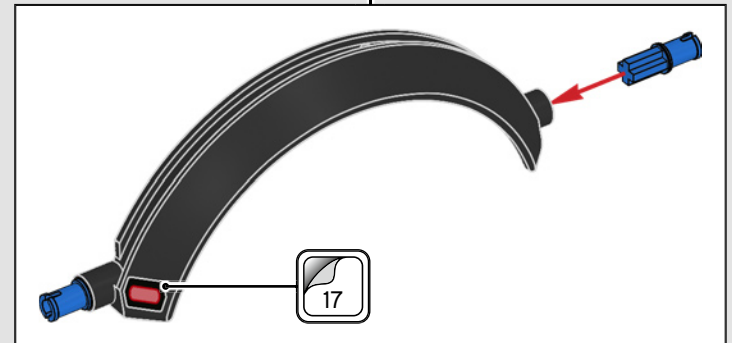
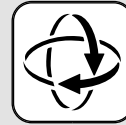

372

The first production Raptor came in a molten orange color with a digital mud graphic.

La première Raptor de production était de couleur orange lave, avec un motif de boue.

La primera Raptor fabricada en serie se puso a la venta en un intenso color naranja con detalles gráficos de estilo digital que representaban manchas de lodo.

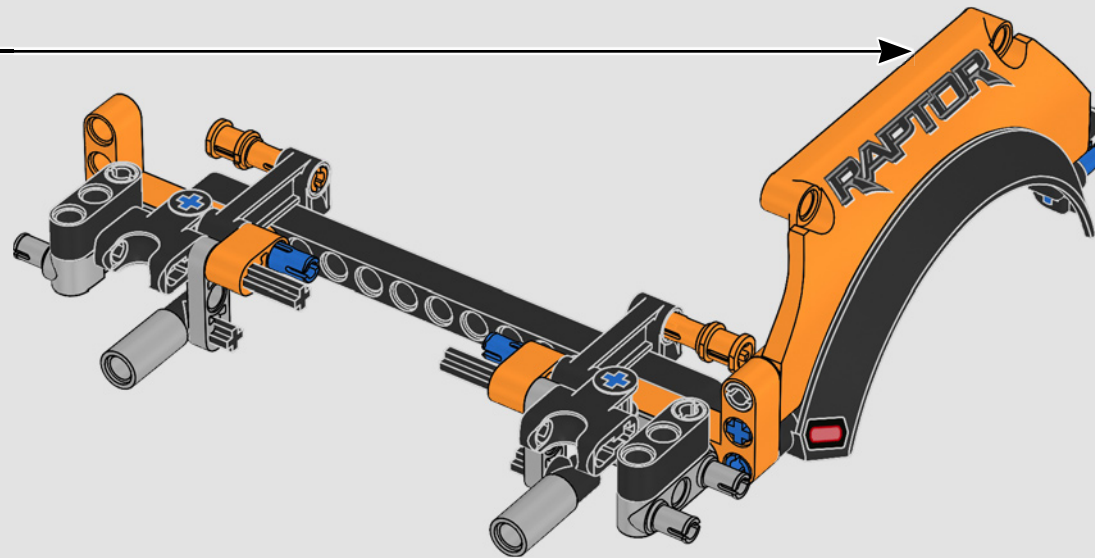

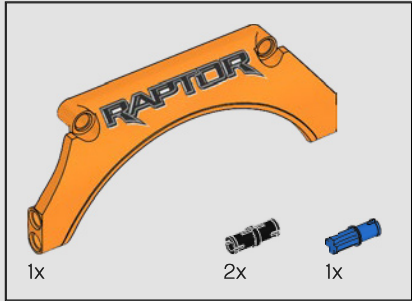

373

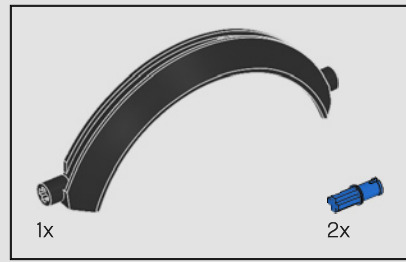
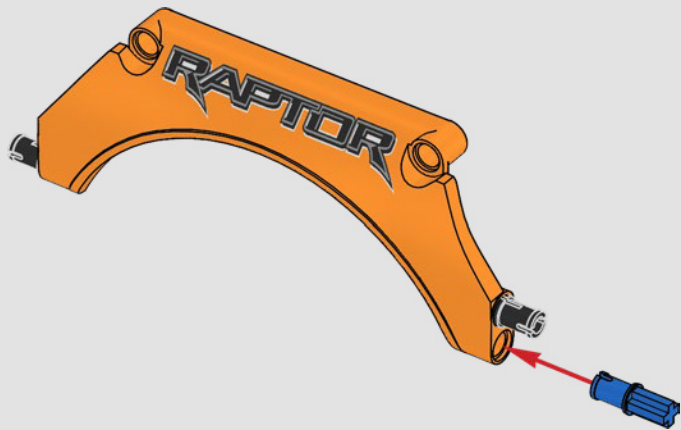

374

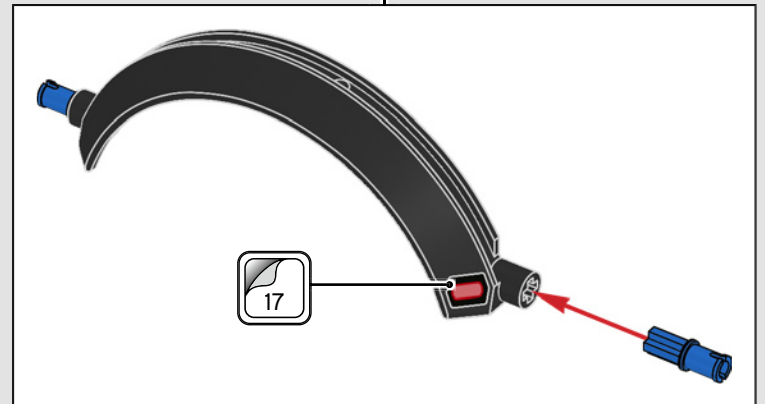

375

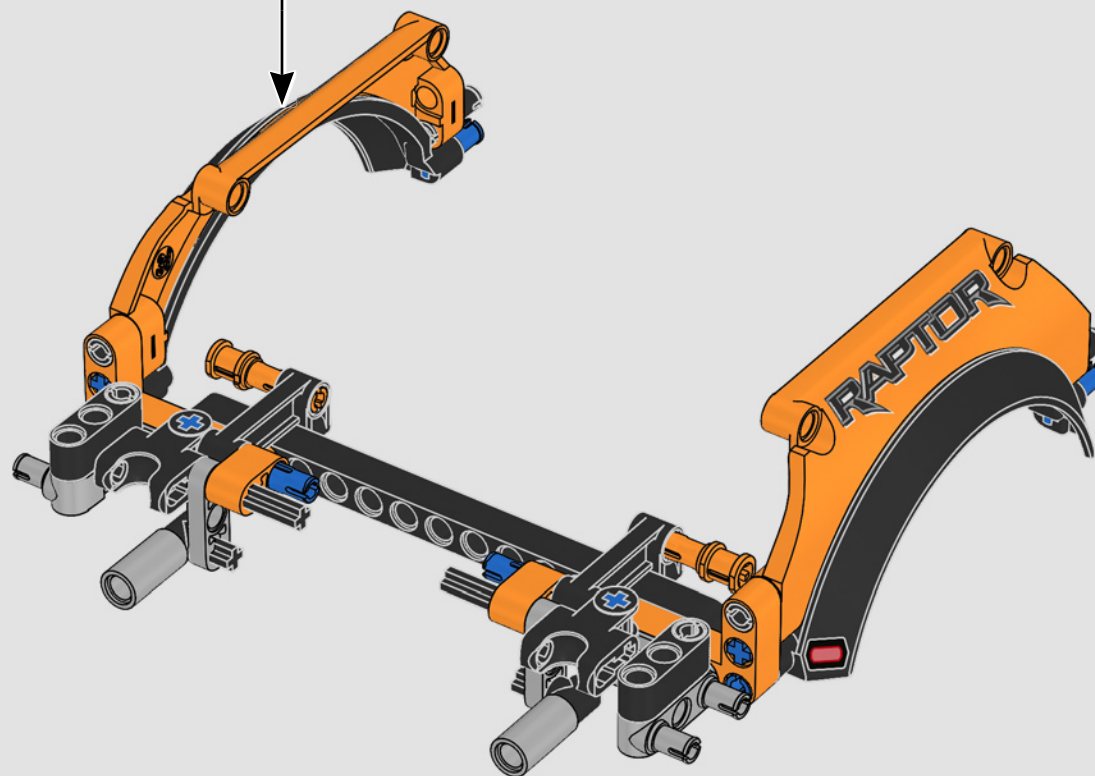

376

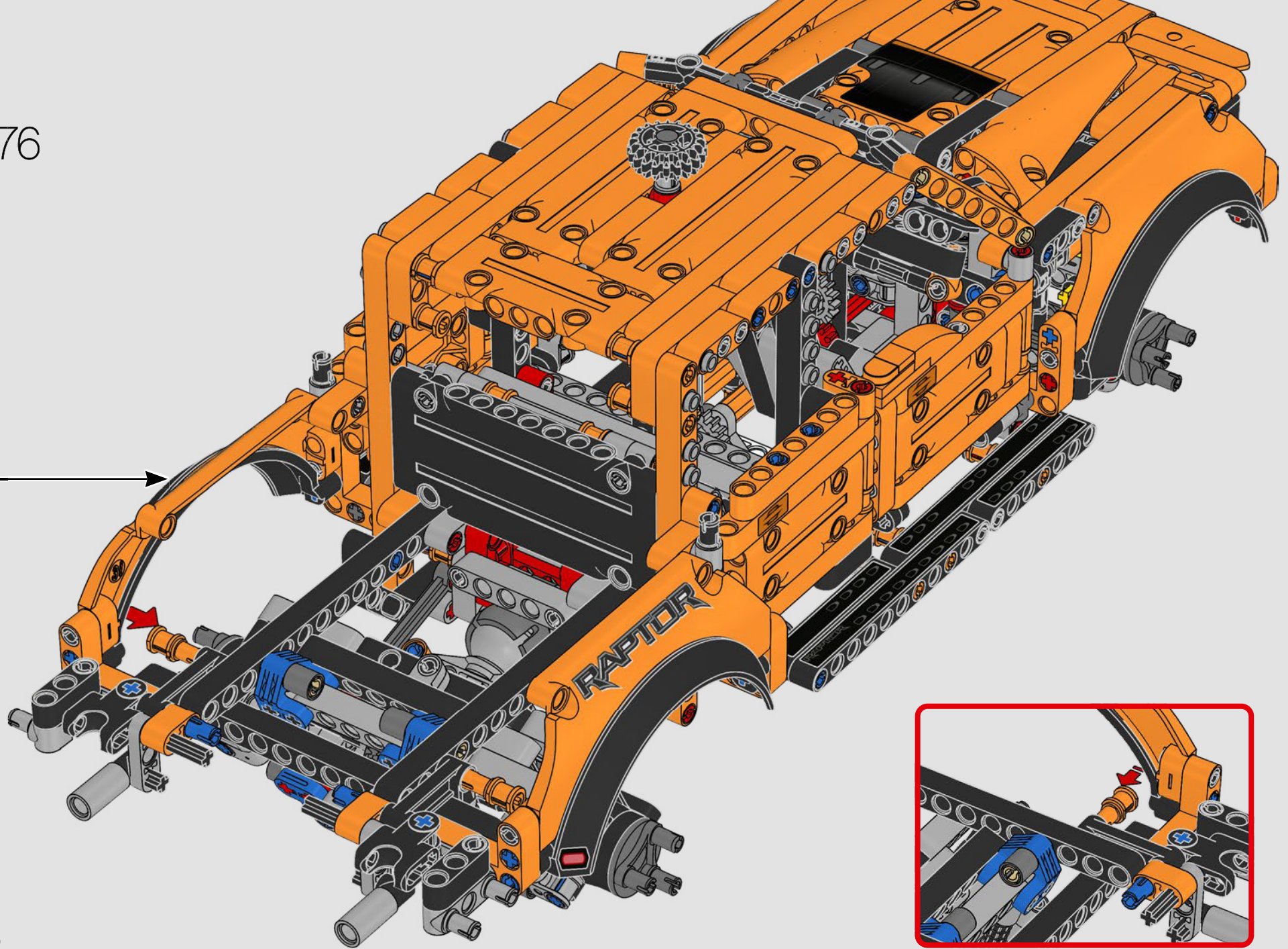

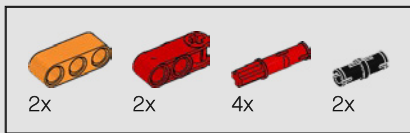

377

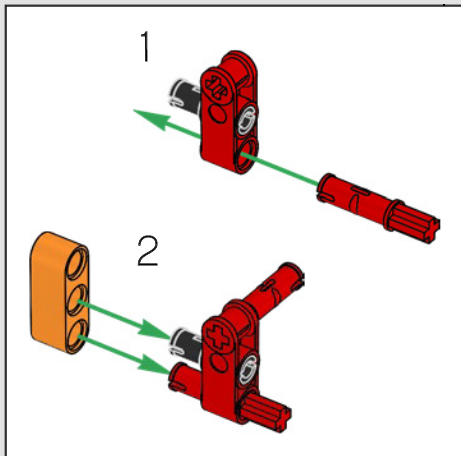
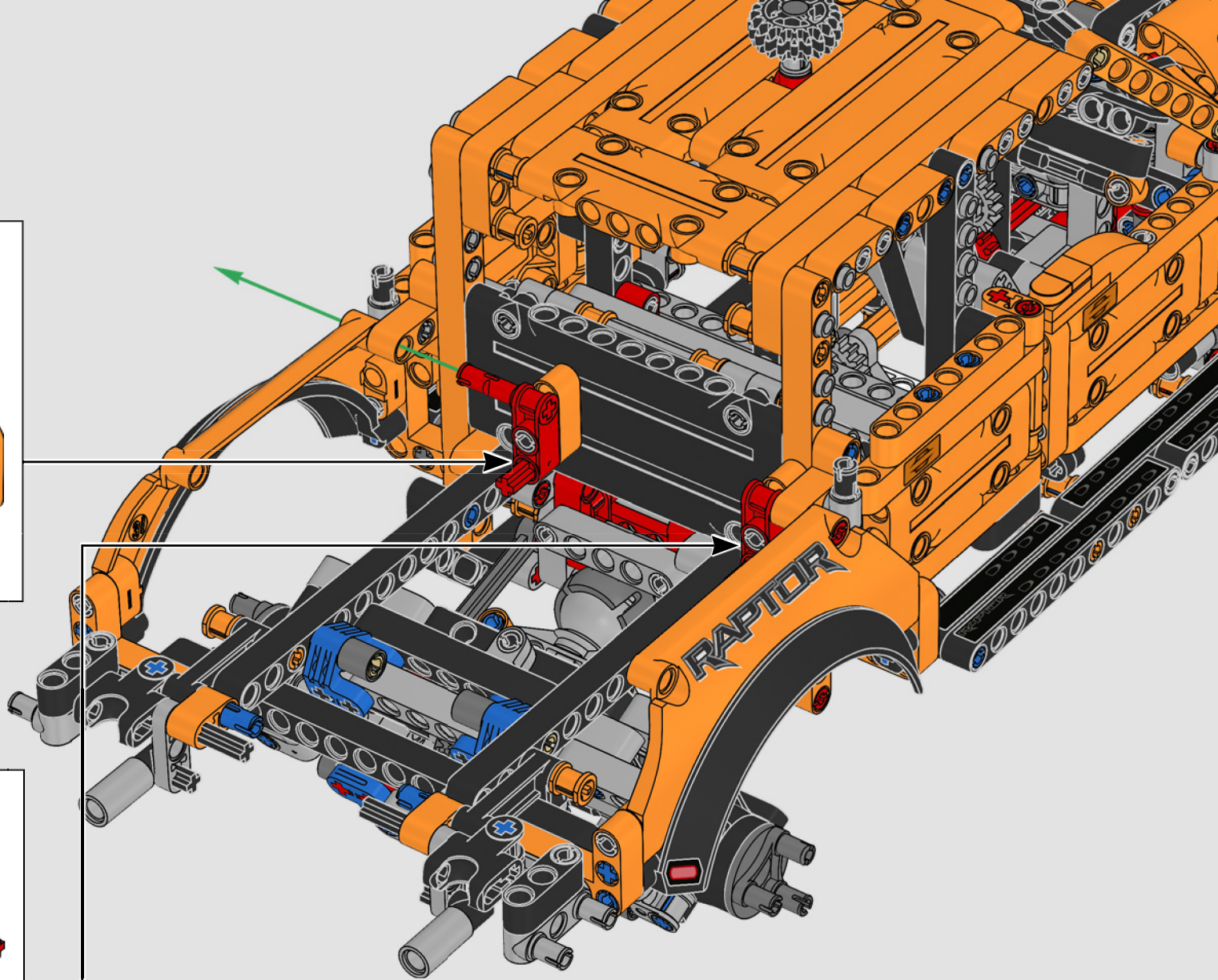
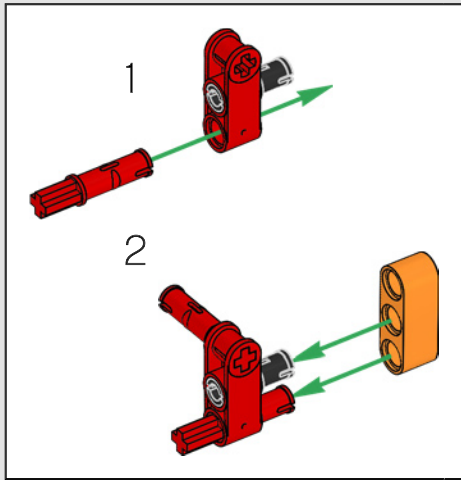

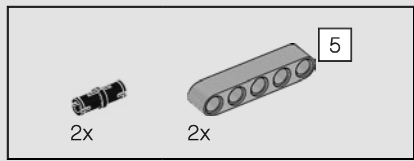

378

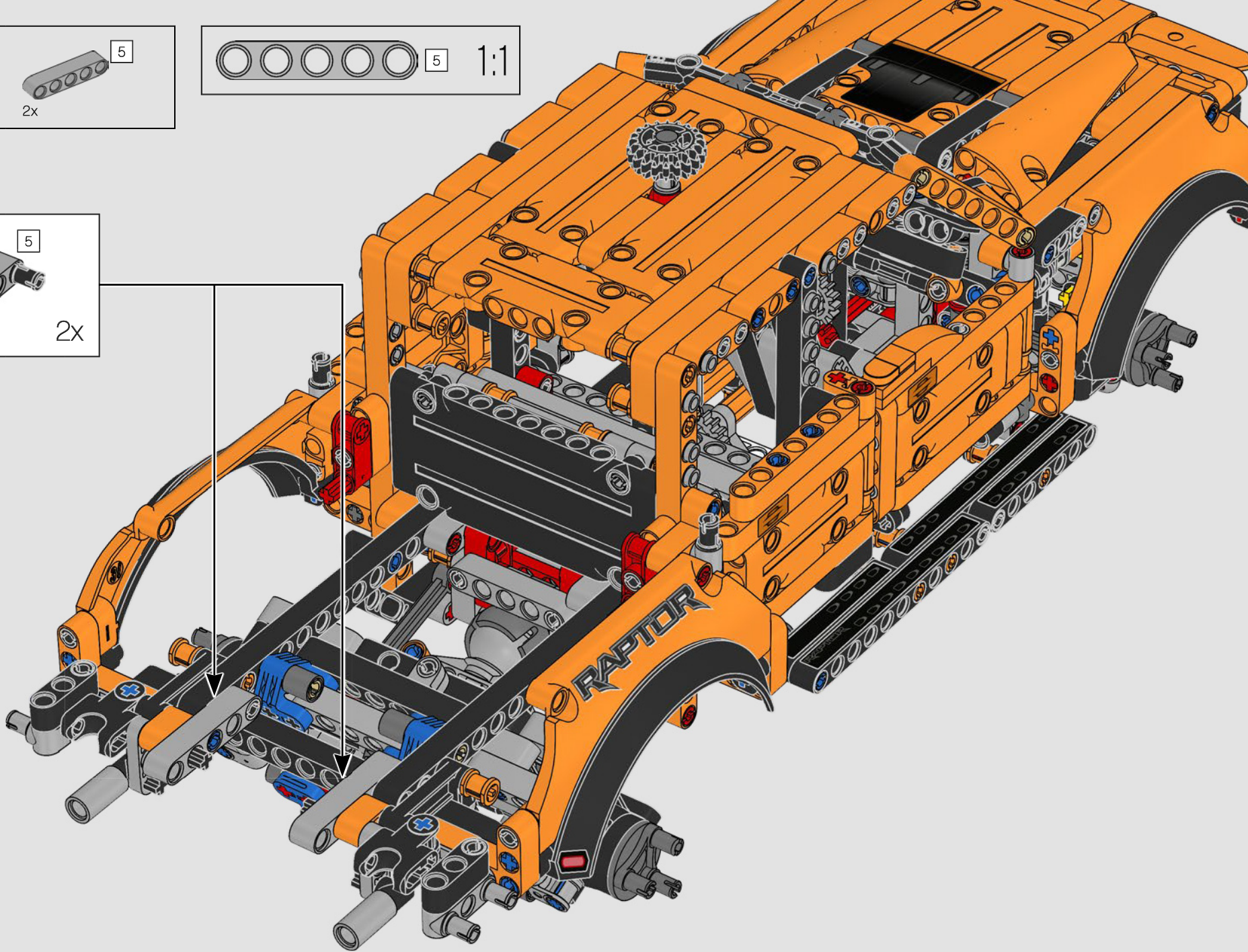
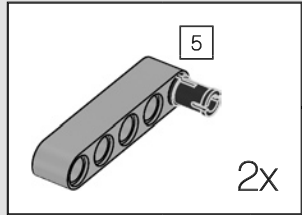

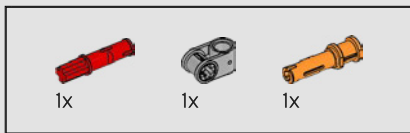

379

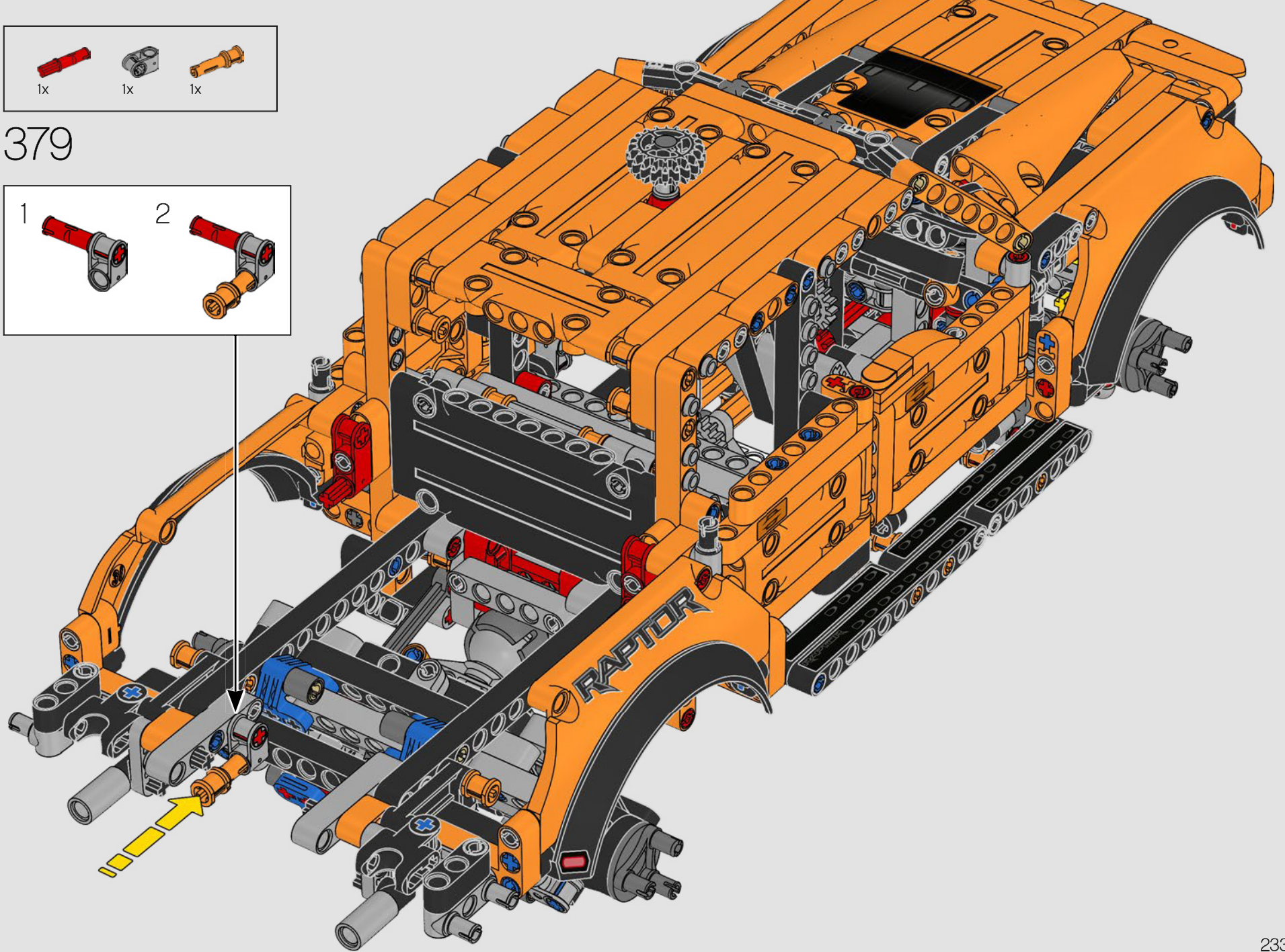
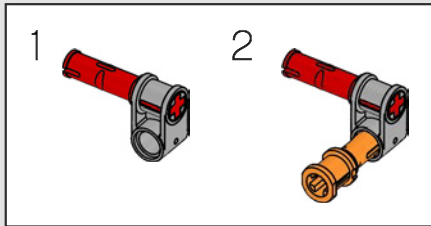

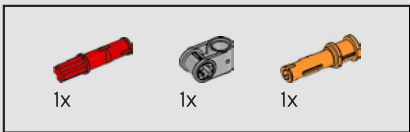

380

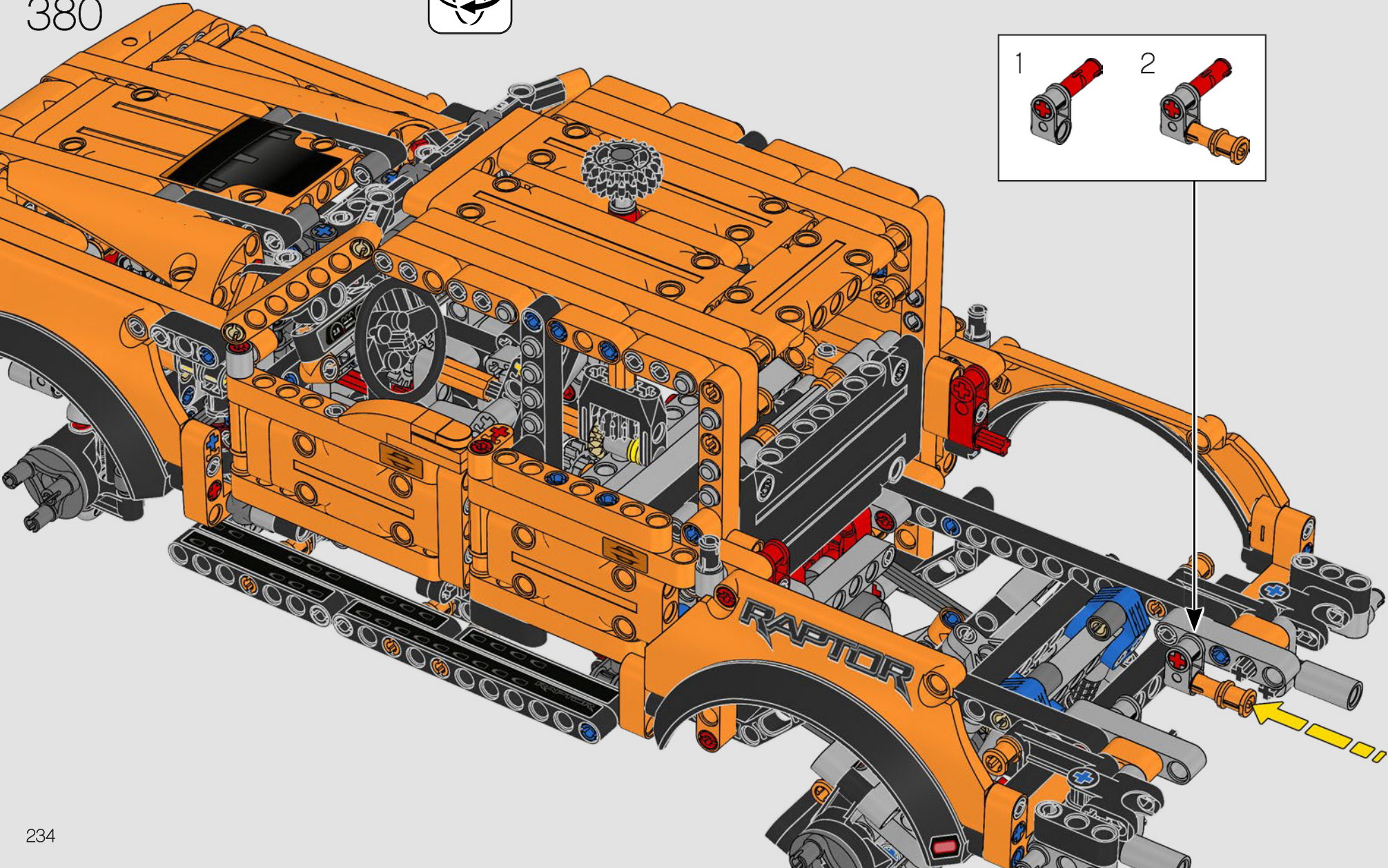
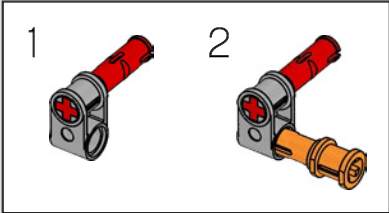

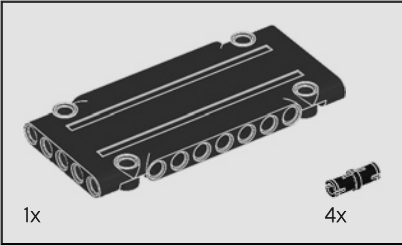
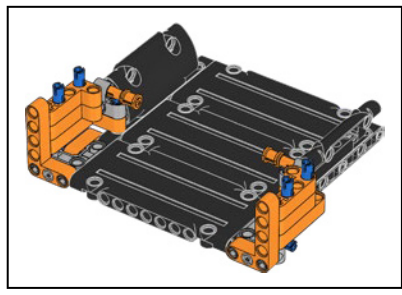

381

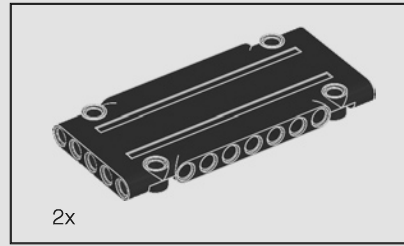
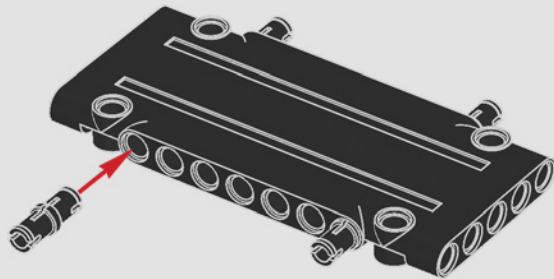

2x

382

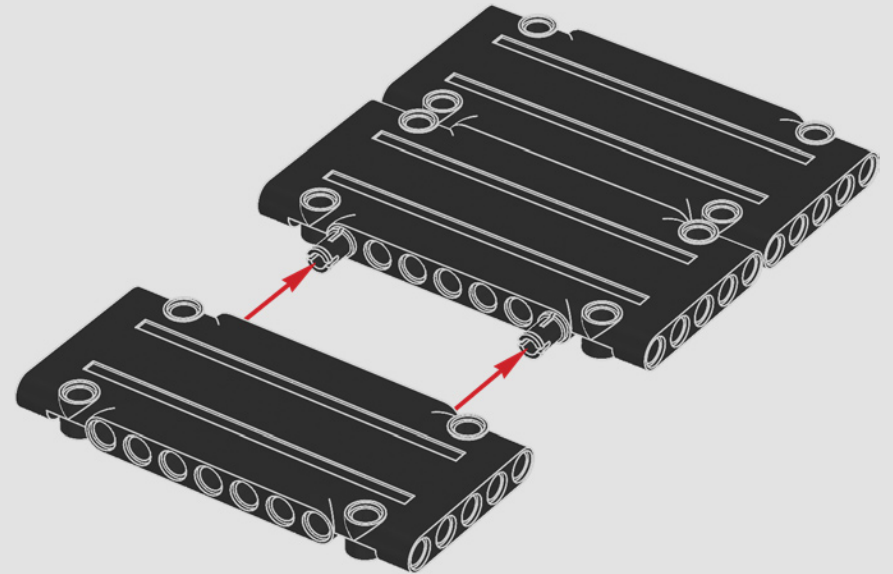



383

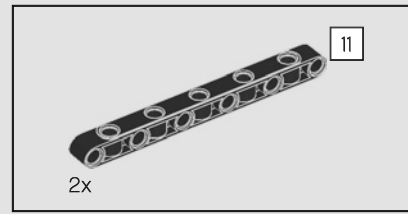
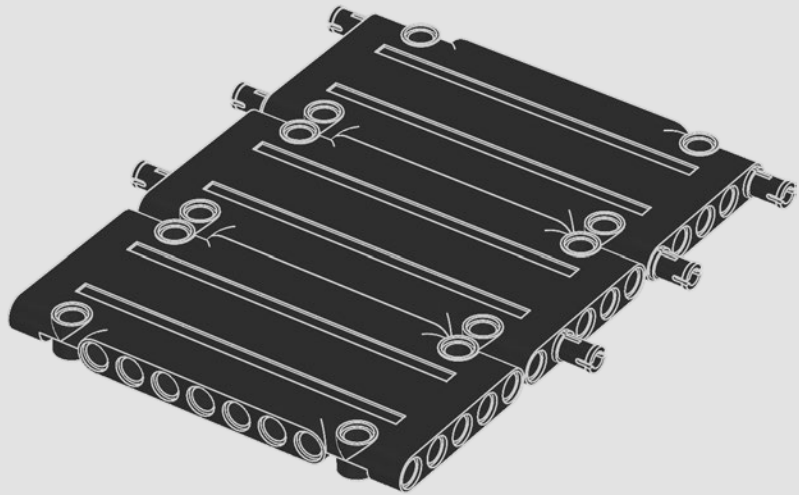

384

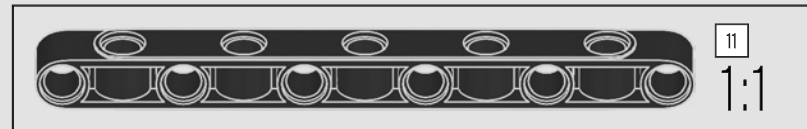
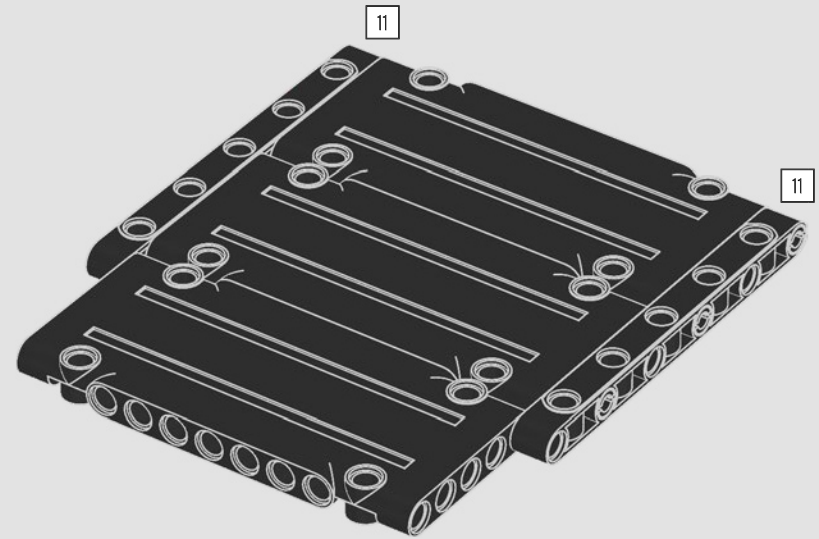

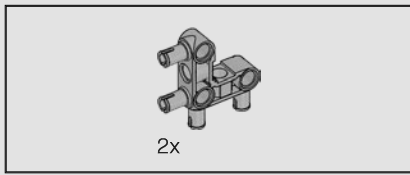

385

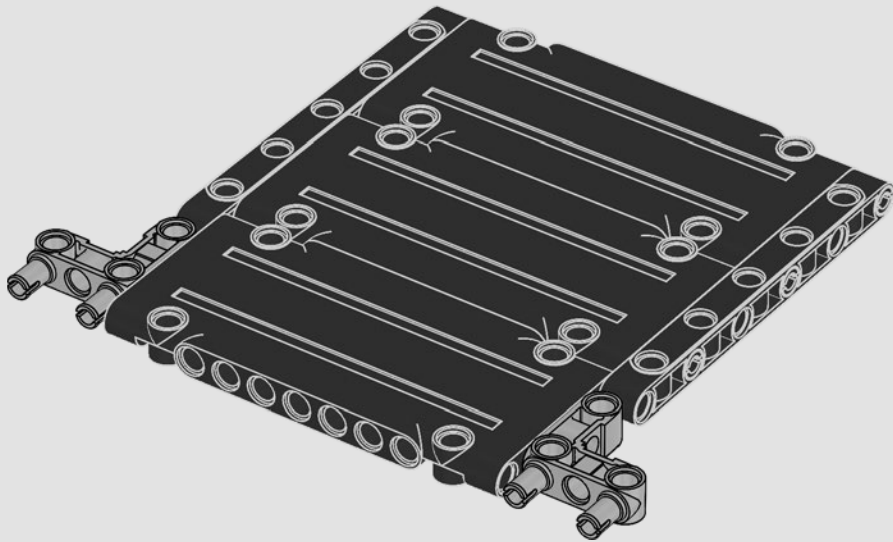

386

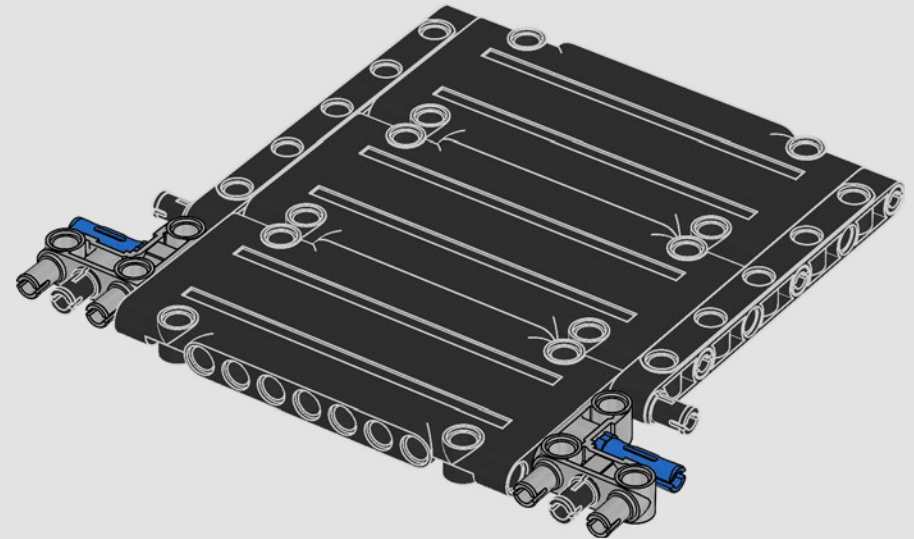

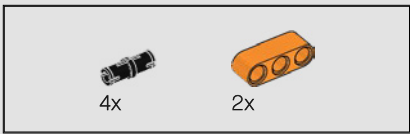

387

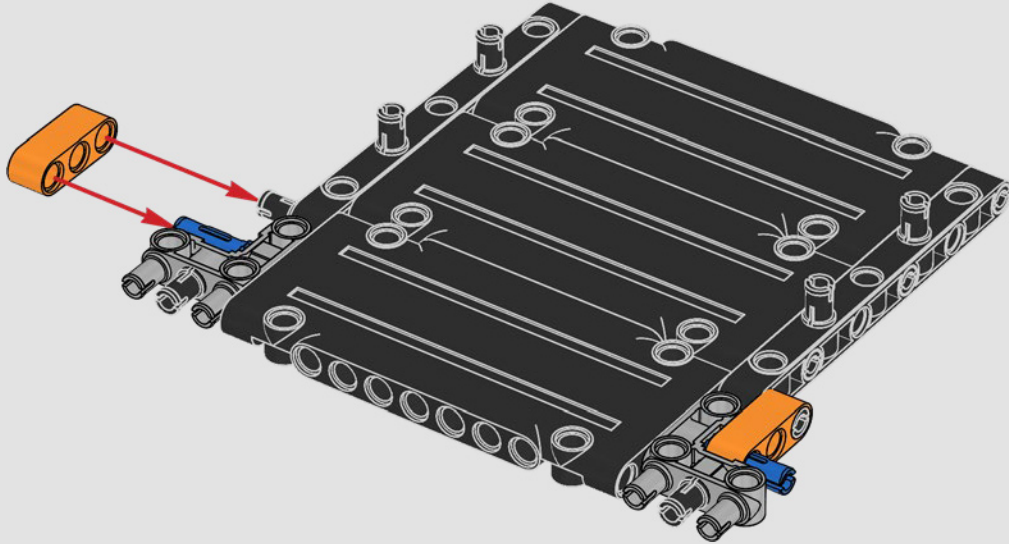

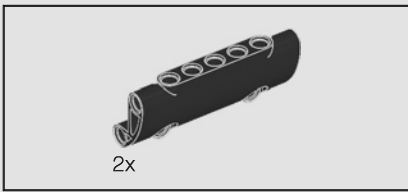

388

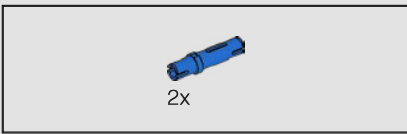
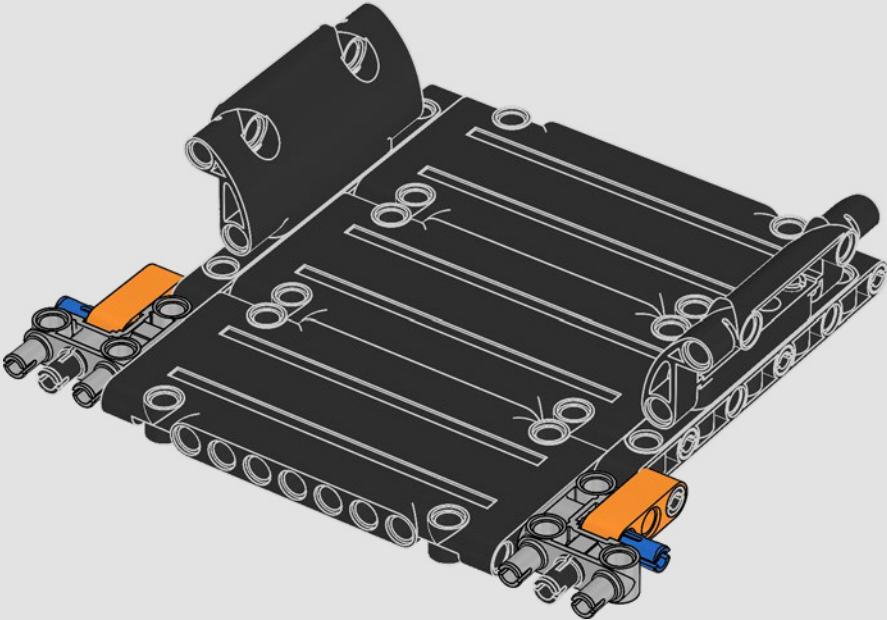

389

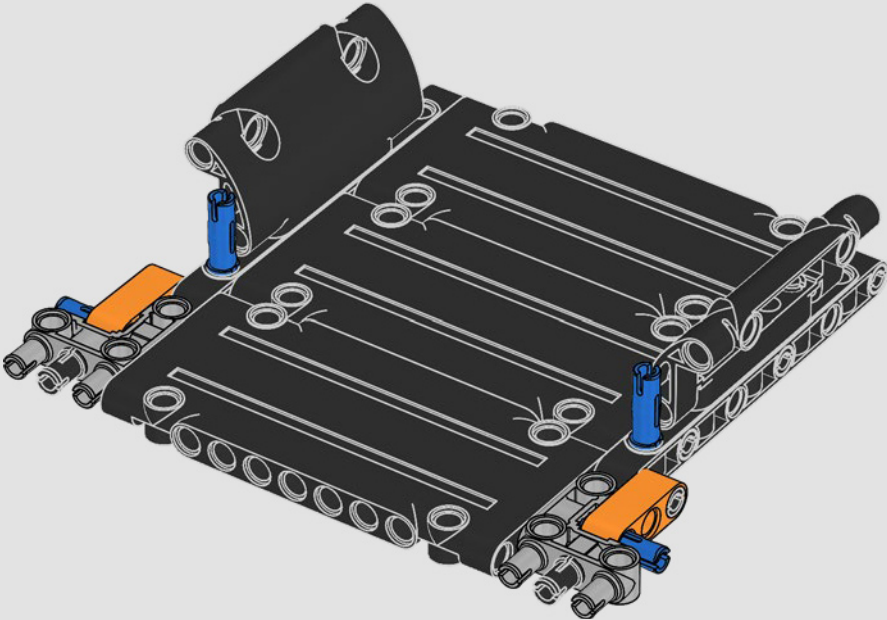

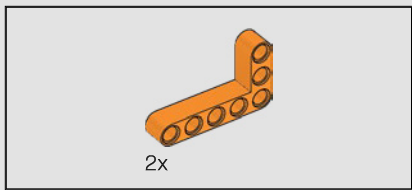

390

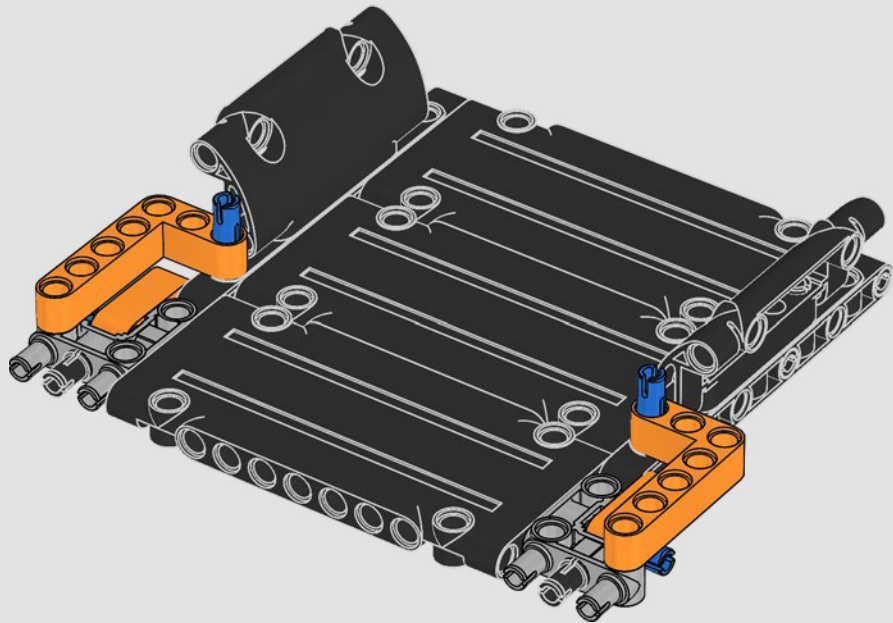

391

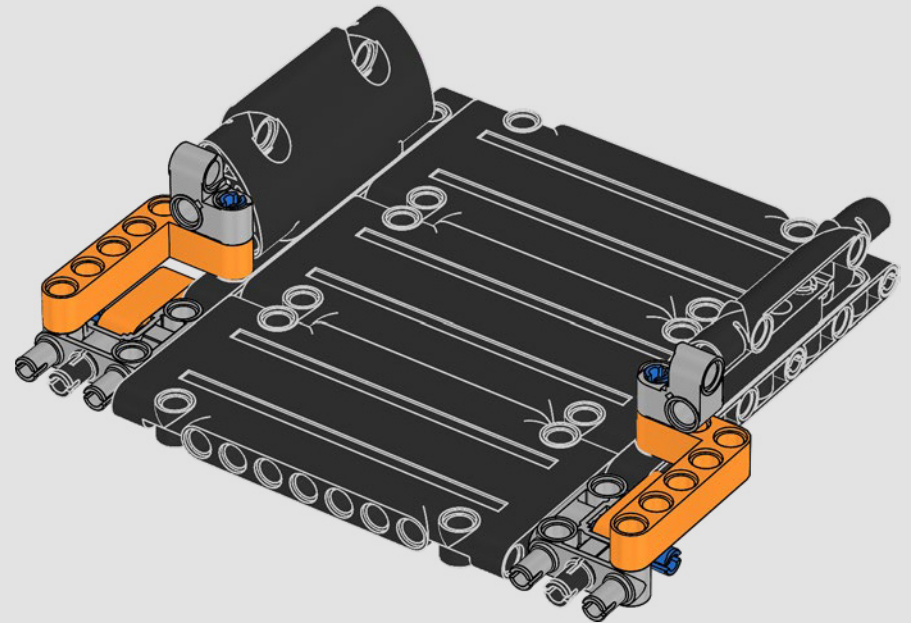

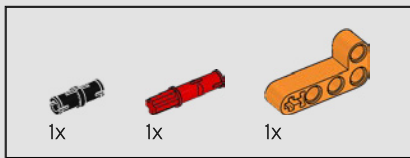

392

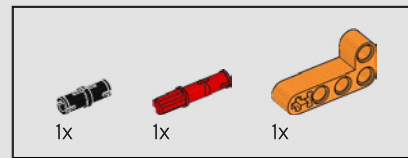
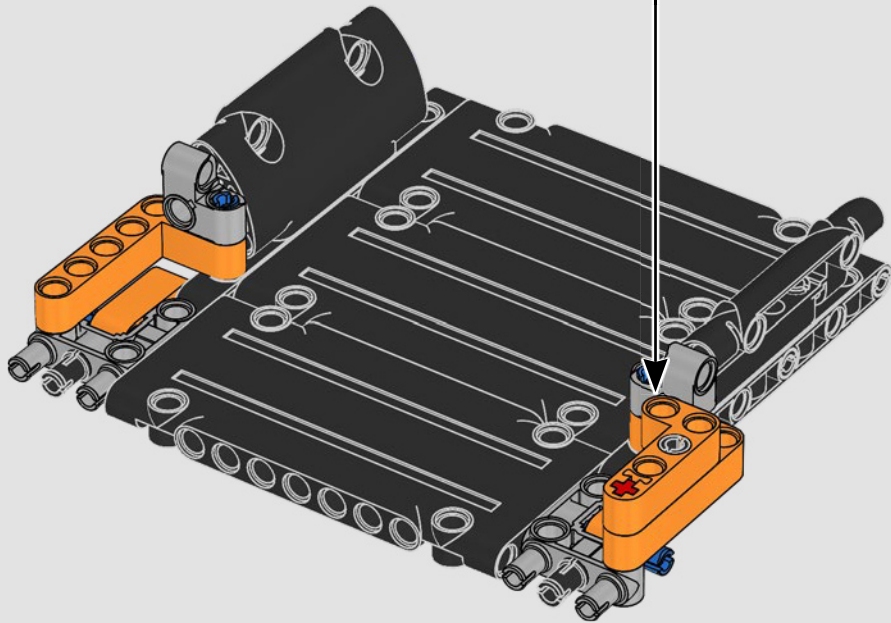
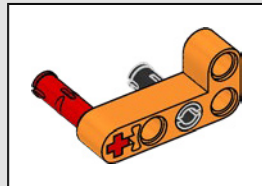

393

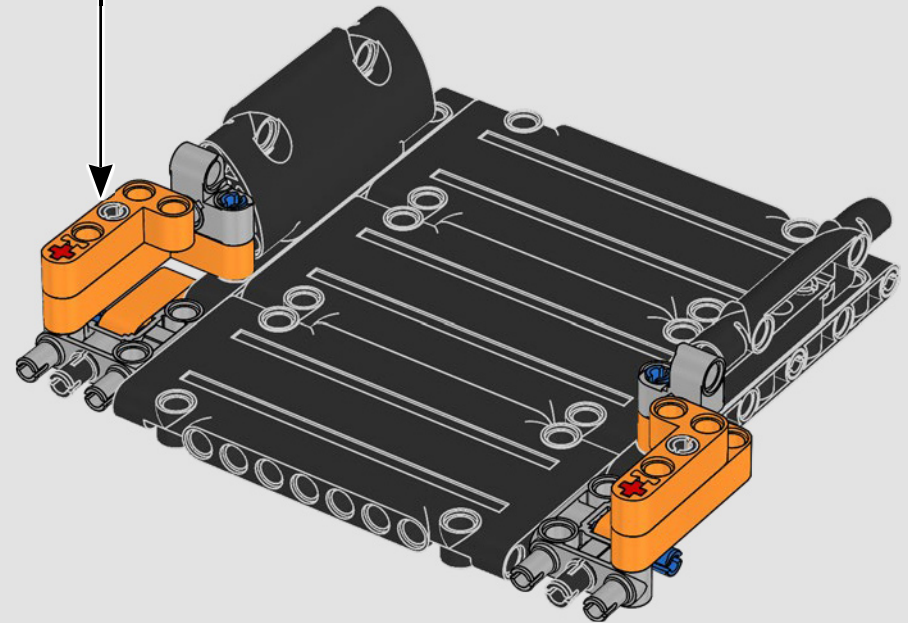
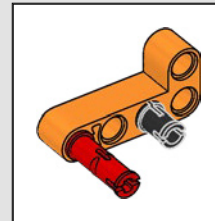

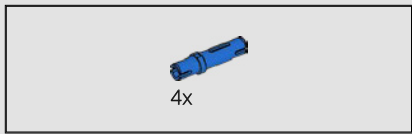

394

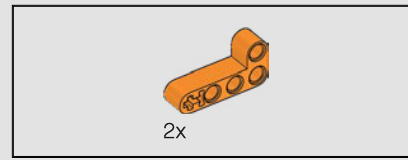
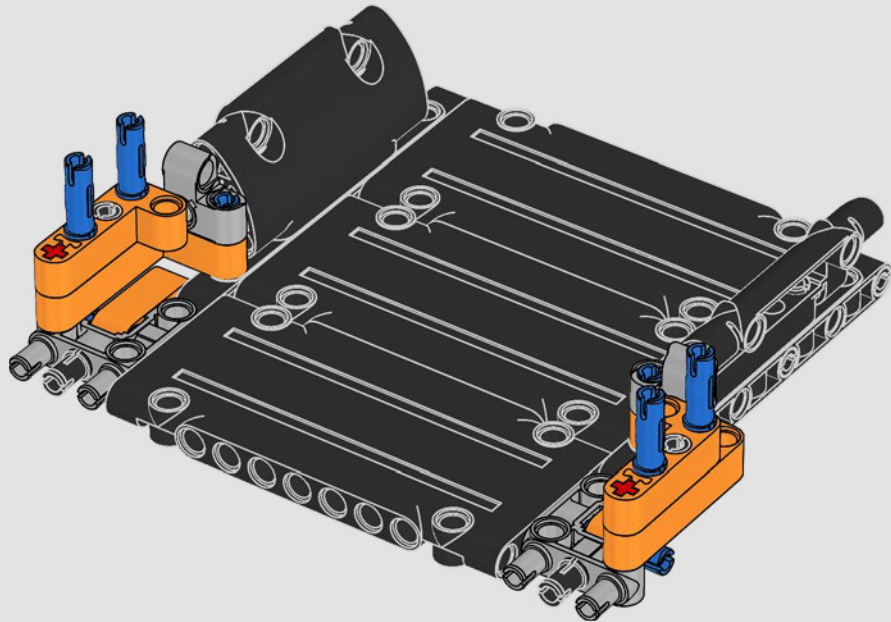

395

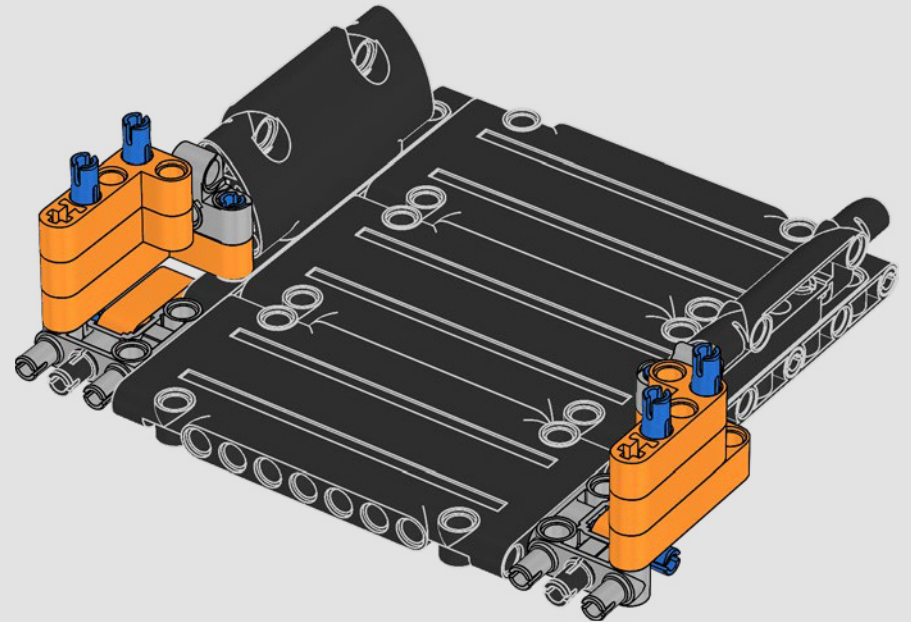

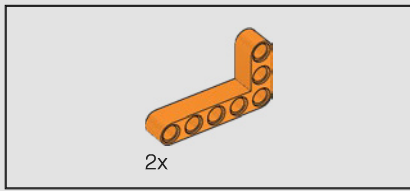

396

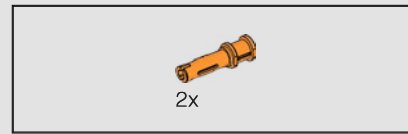
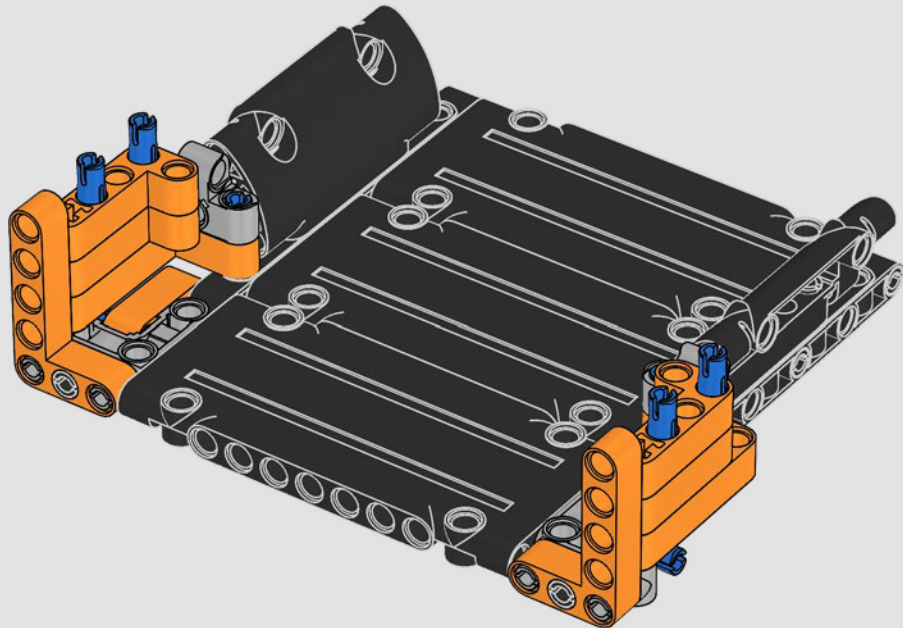

397

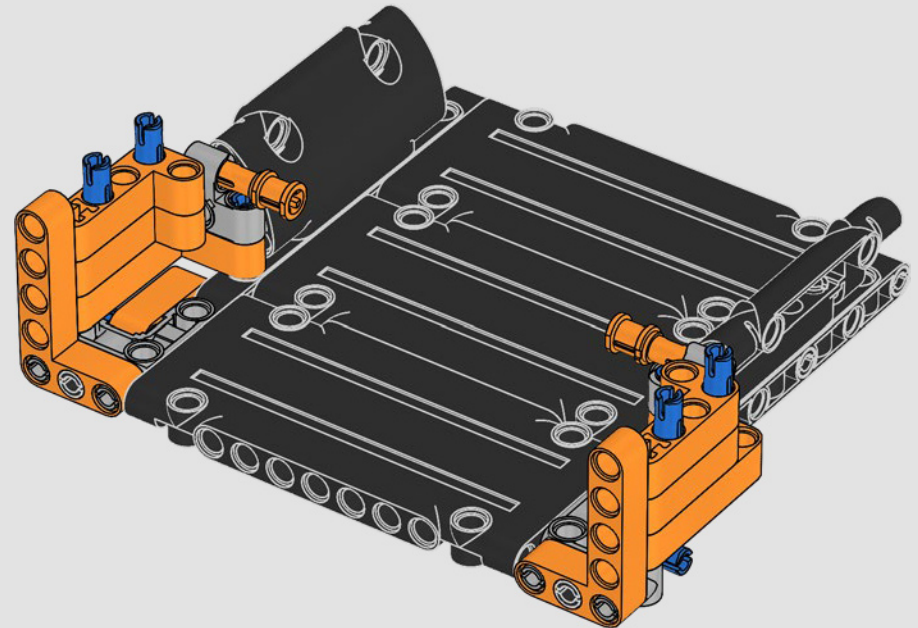

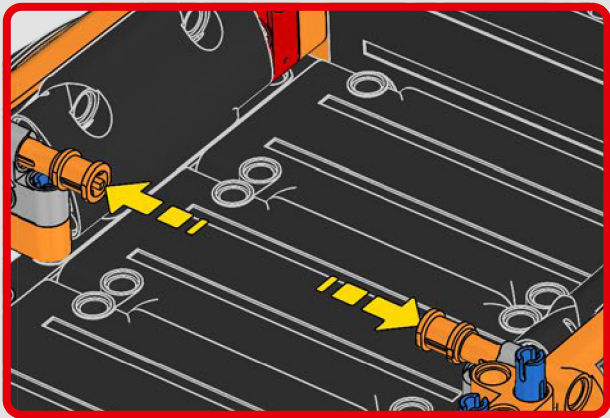

398

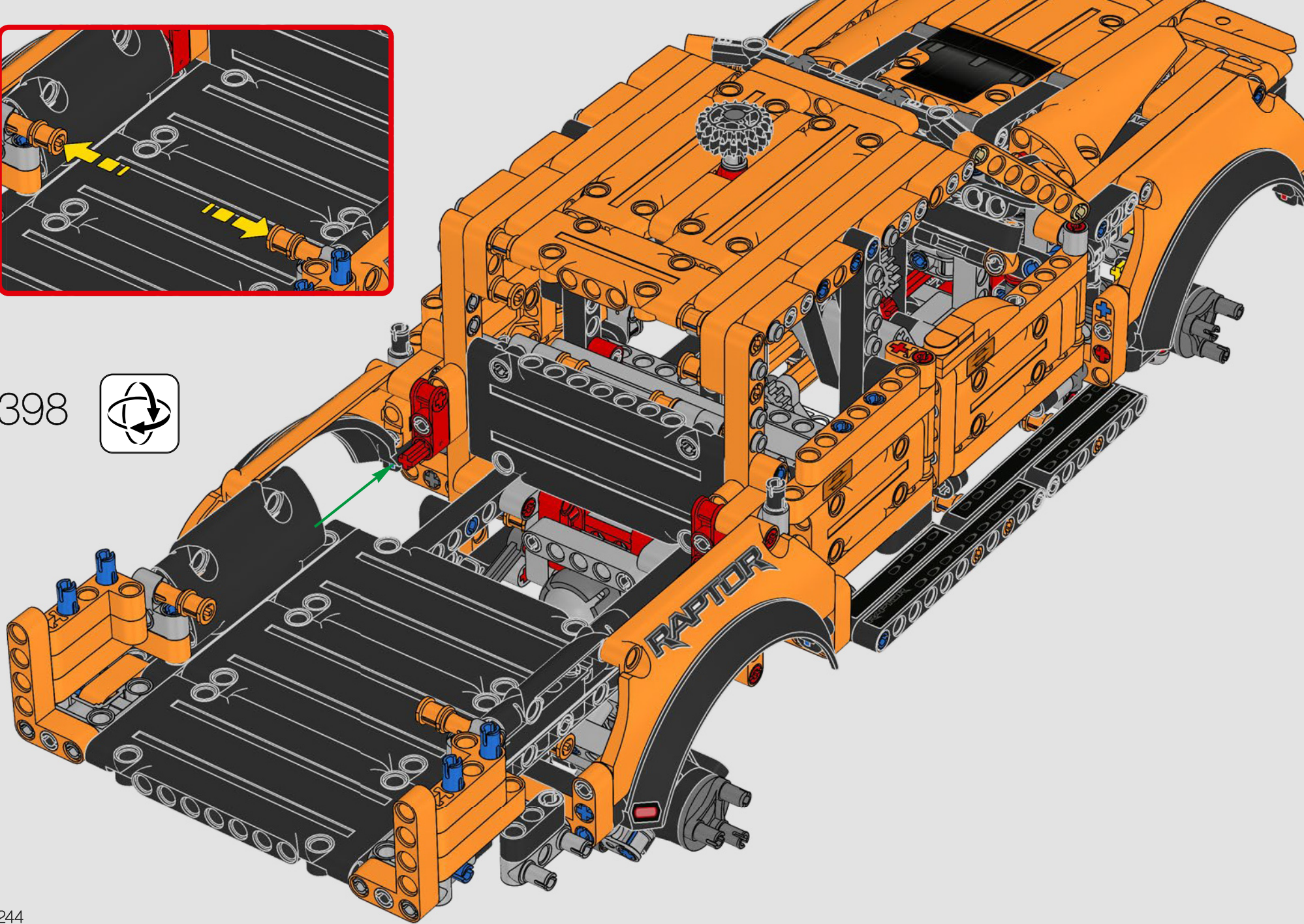

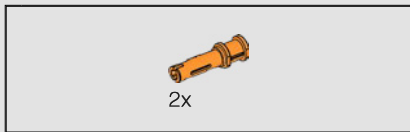

399

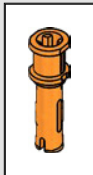
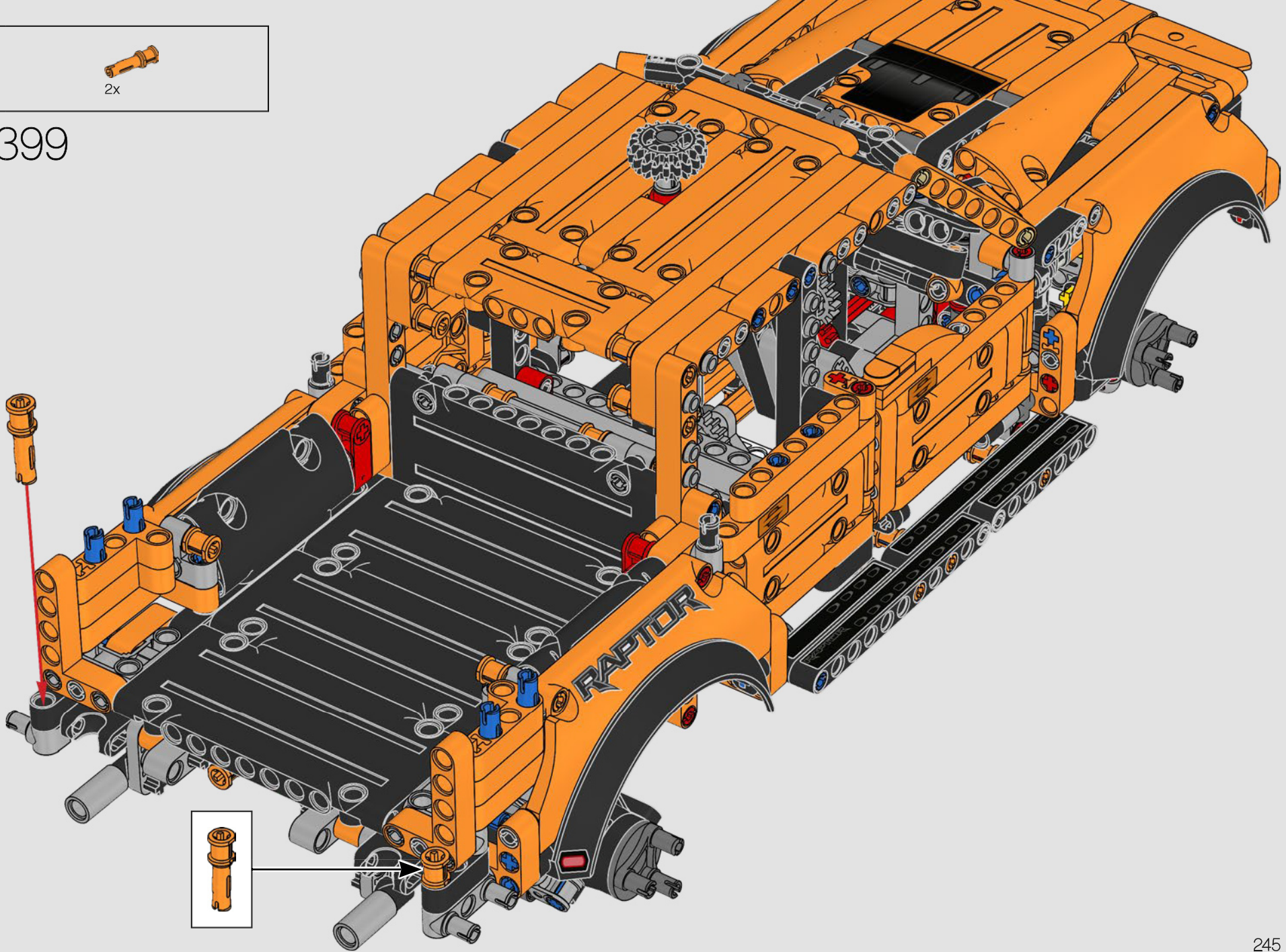



8x

400

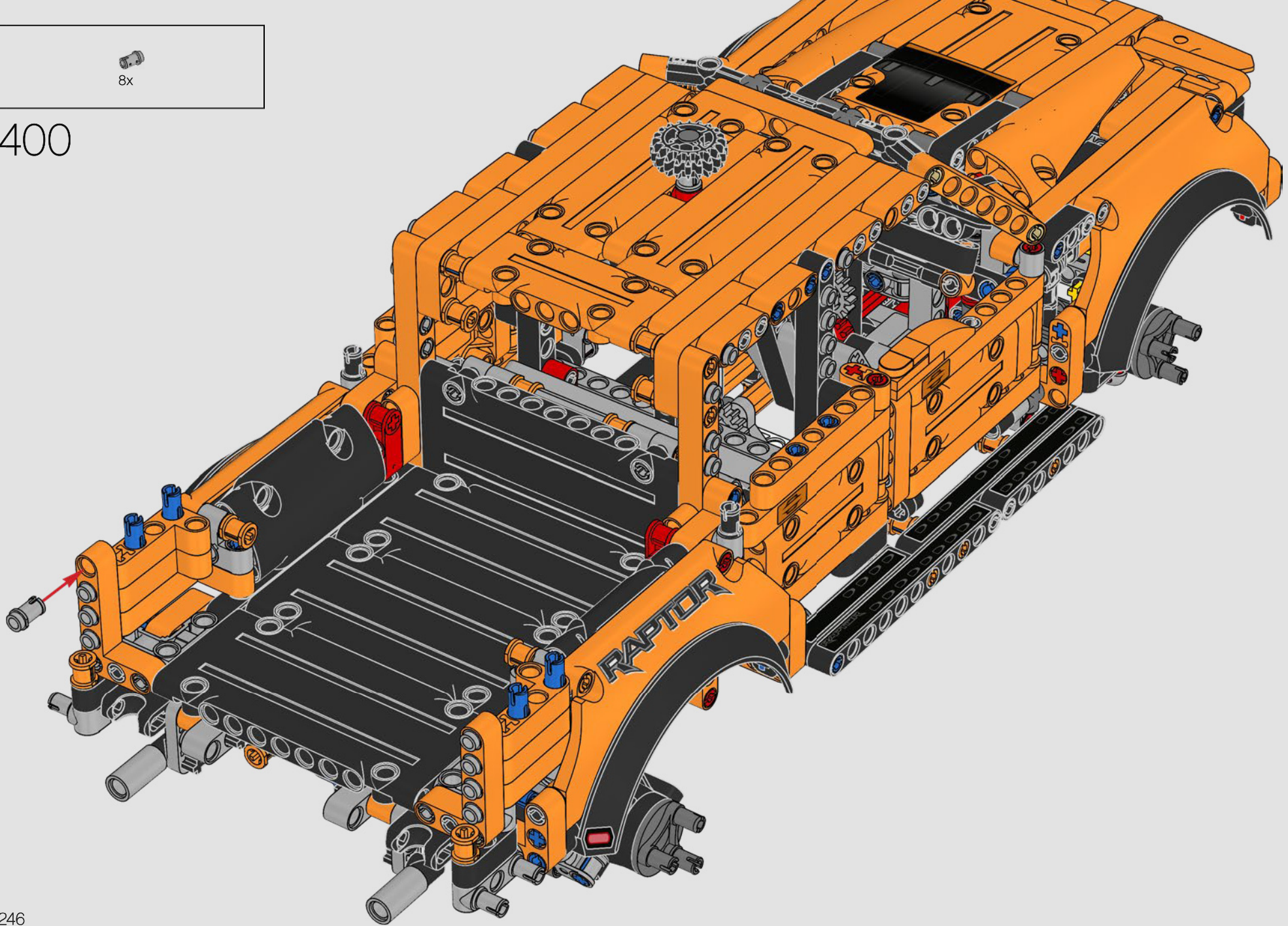



401

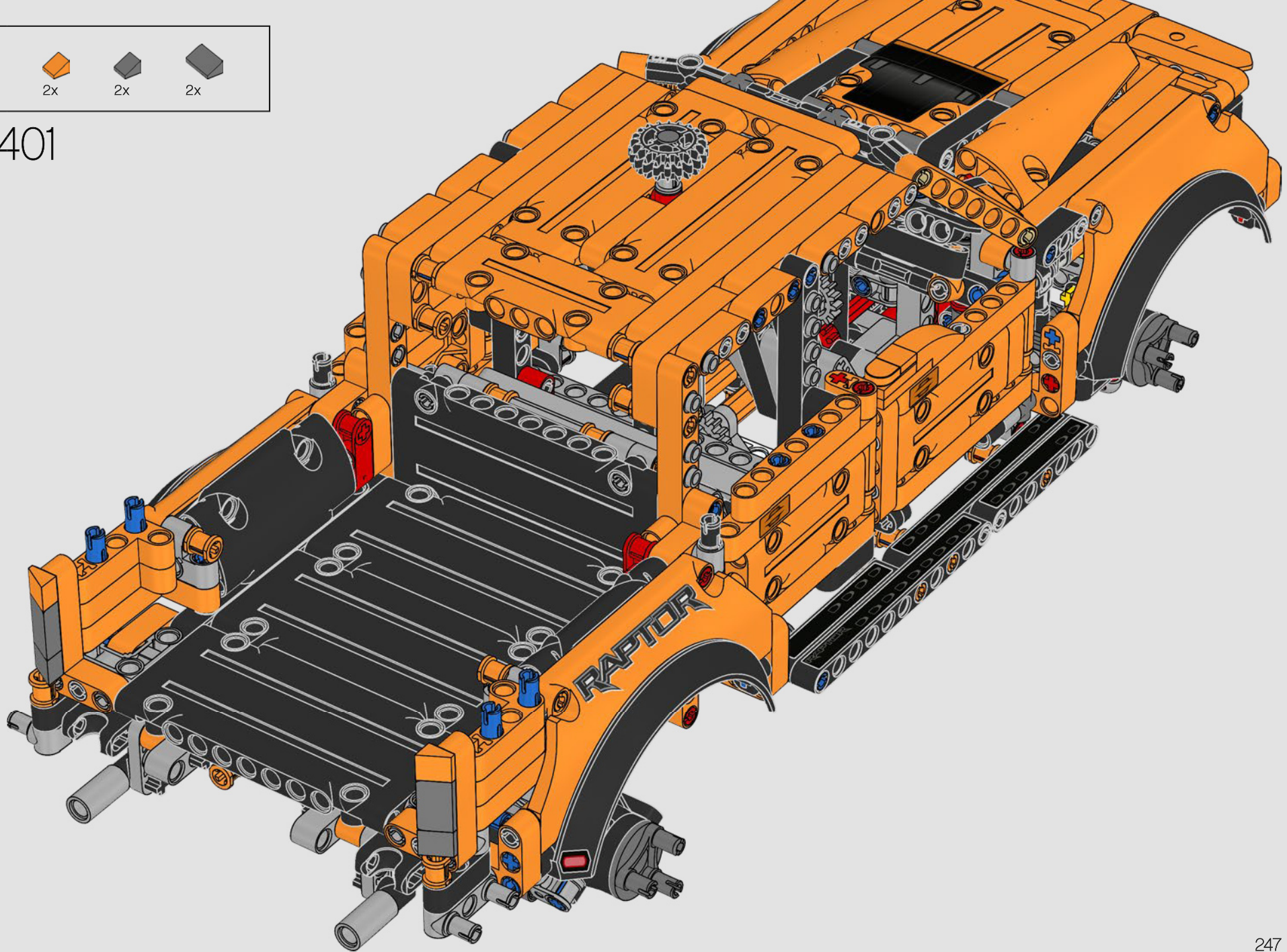

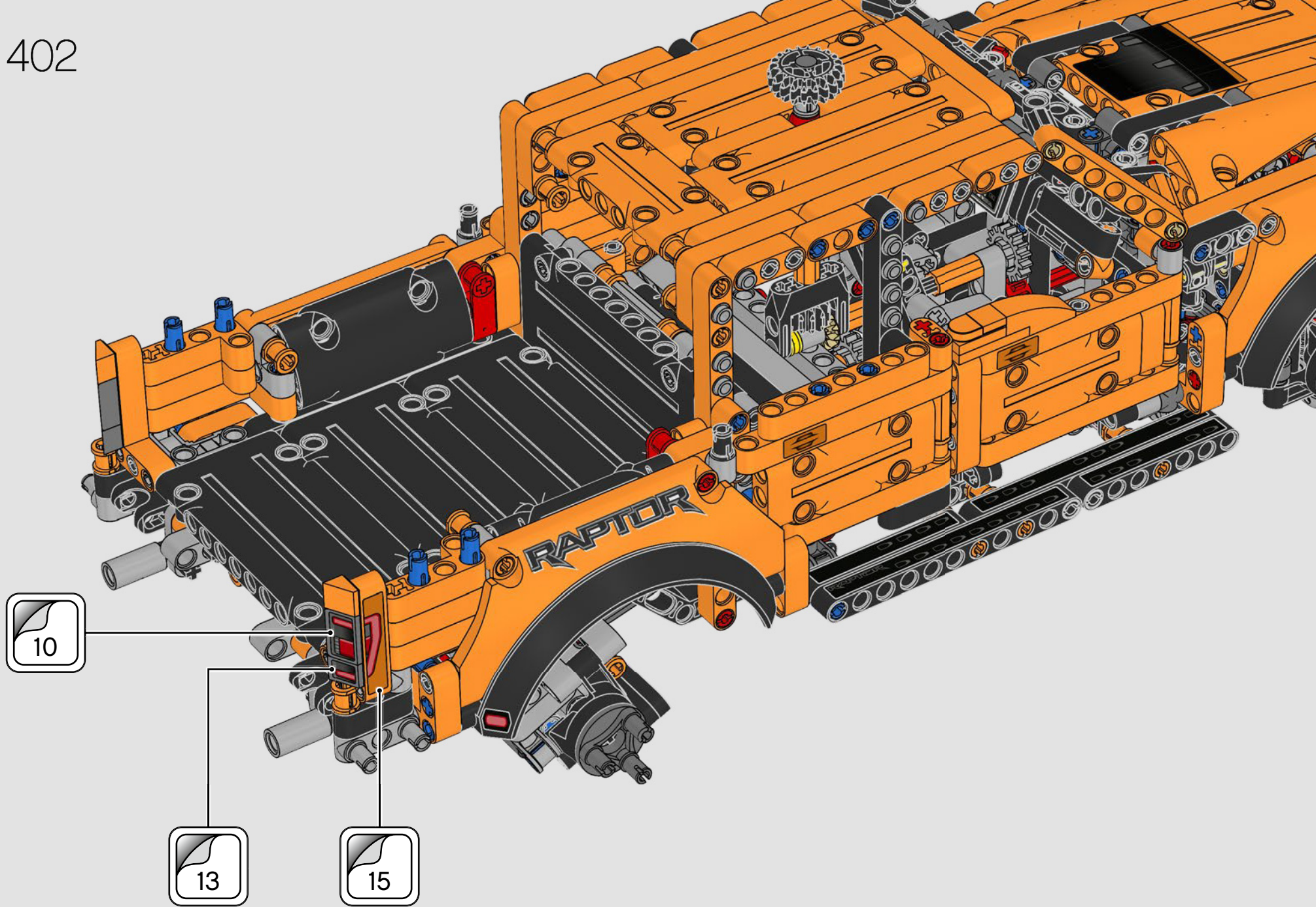

403

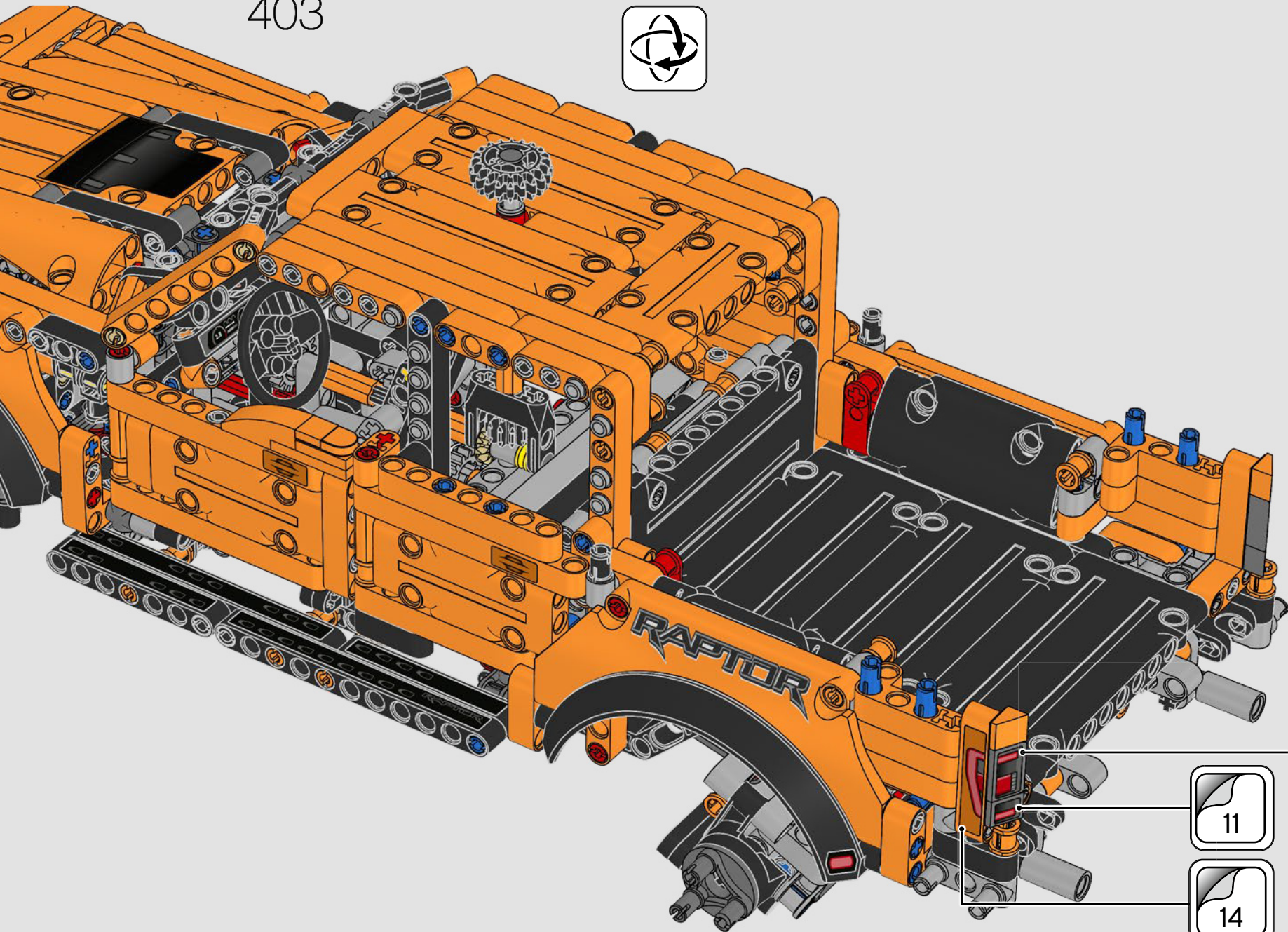
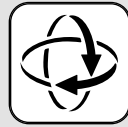

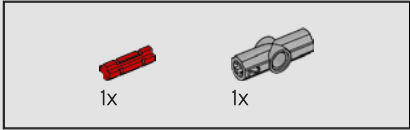
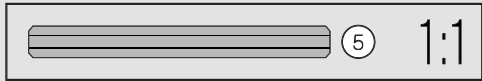
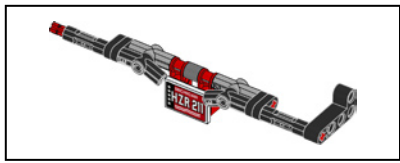

404

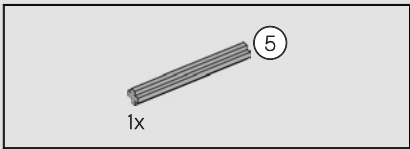
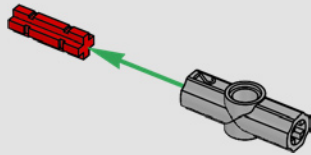

405

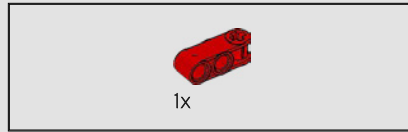
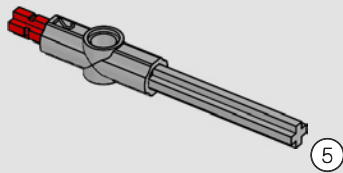

406

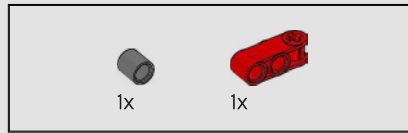
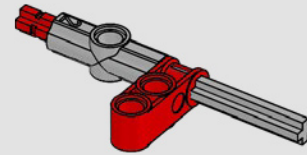

407

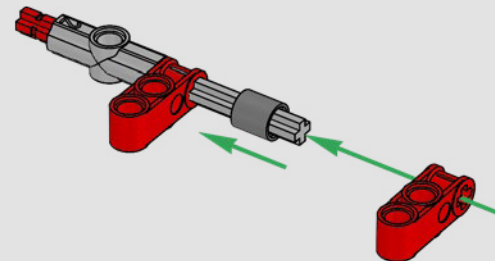

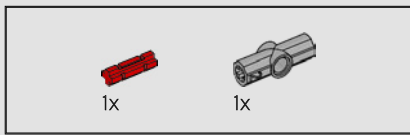

408

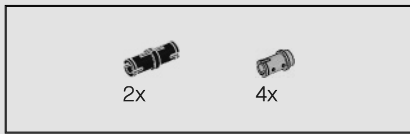
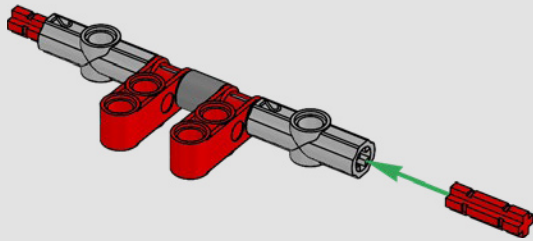

409

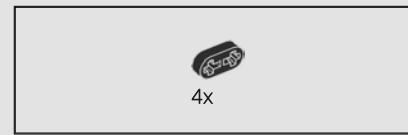
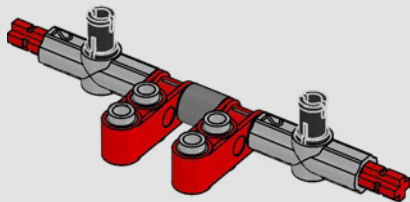

410

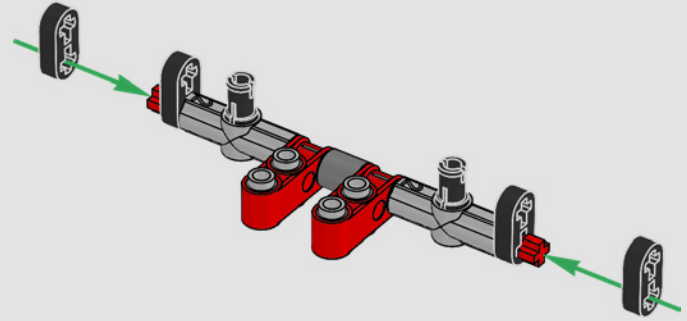

411

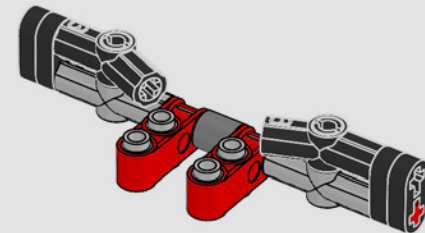

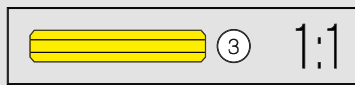
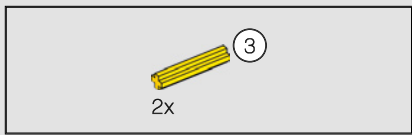

412

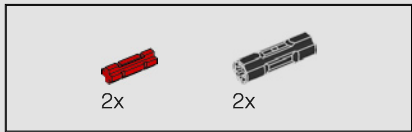
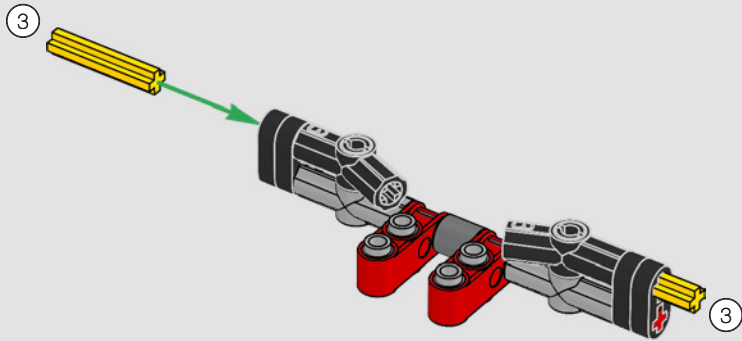

413

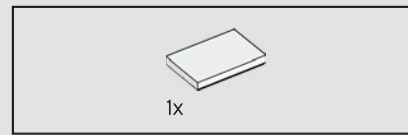
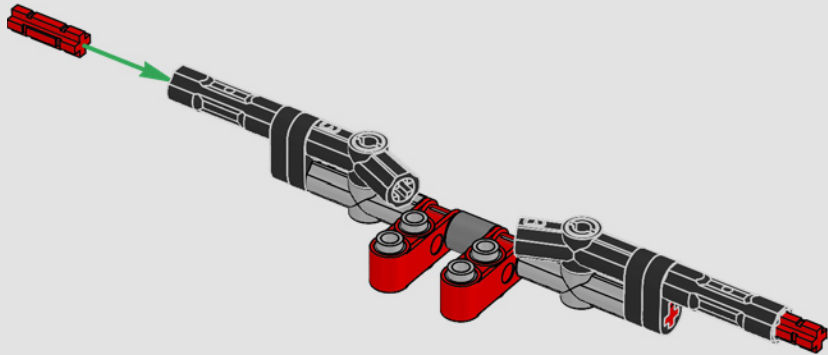

414

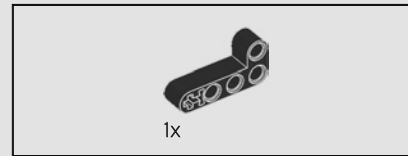
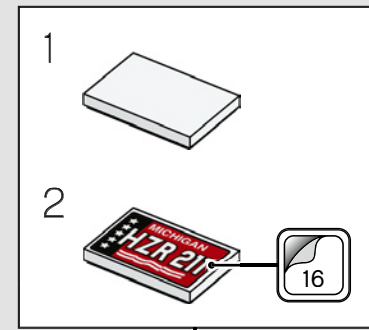
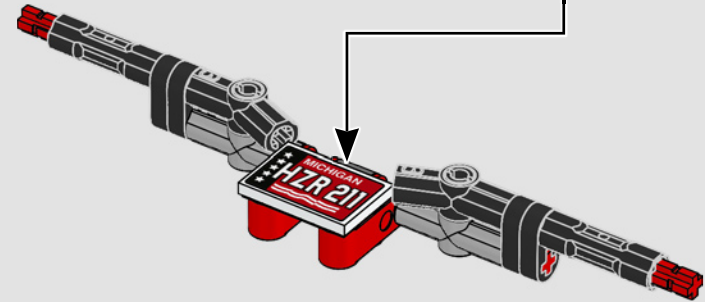

415

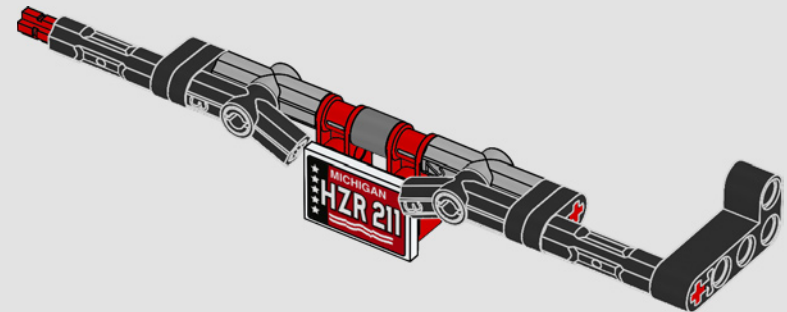
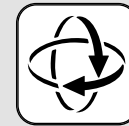

416

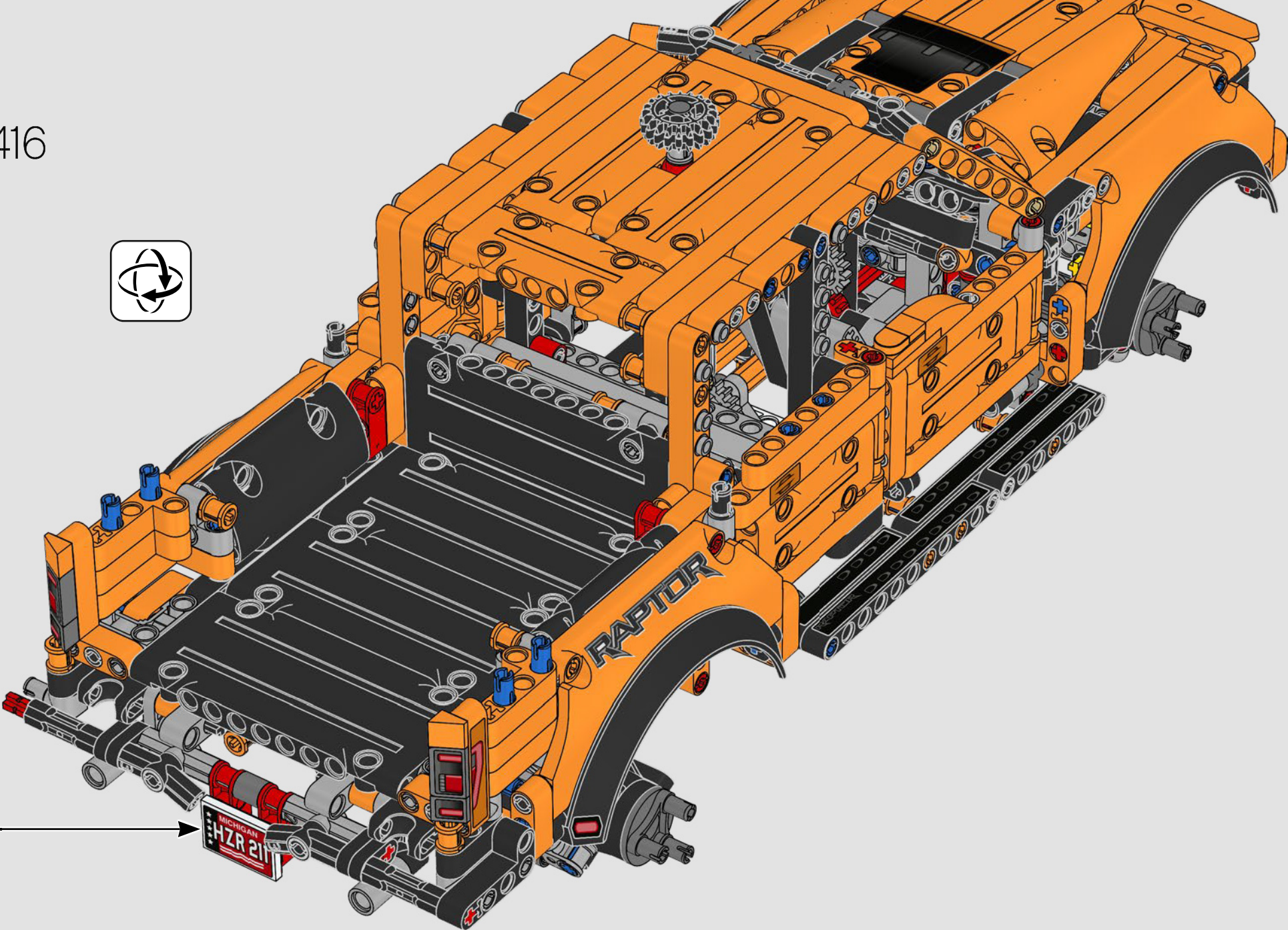

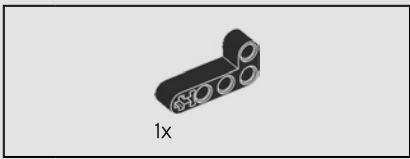

417

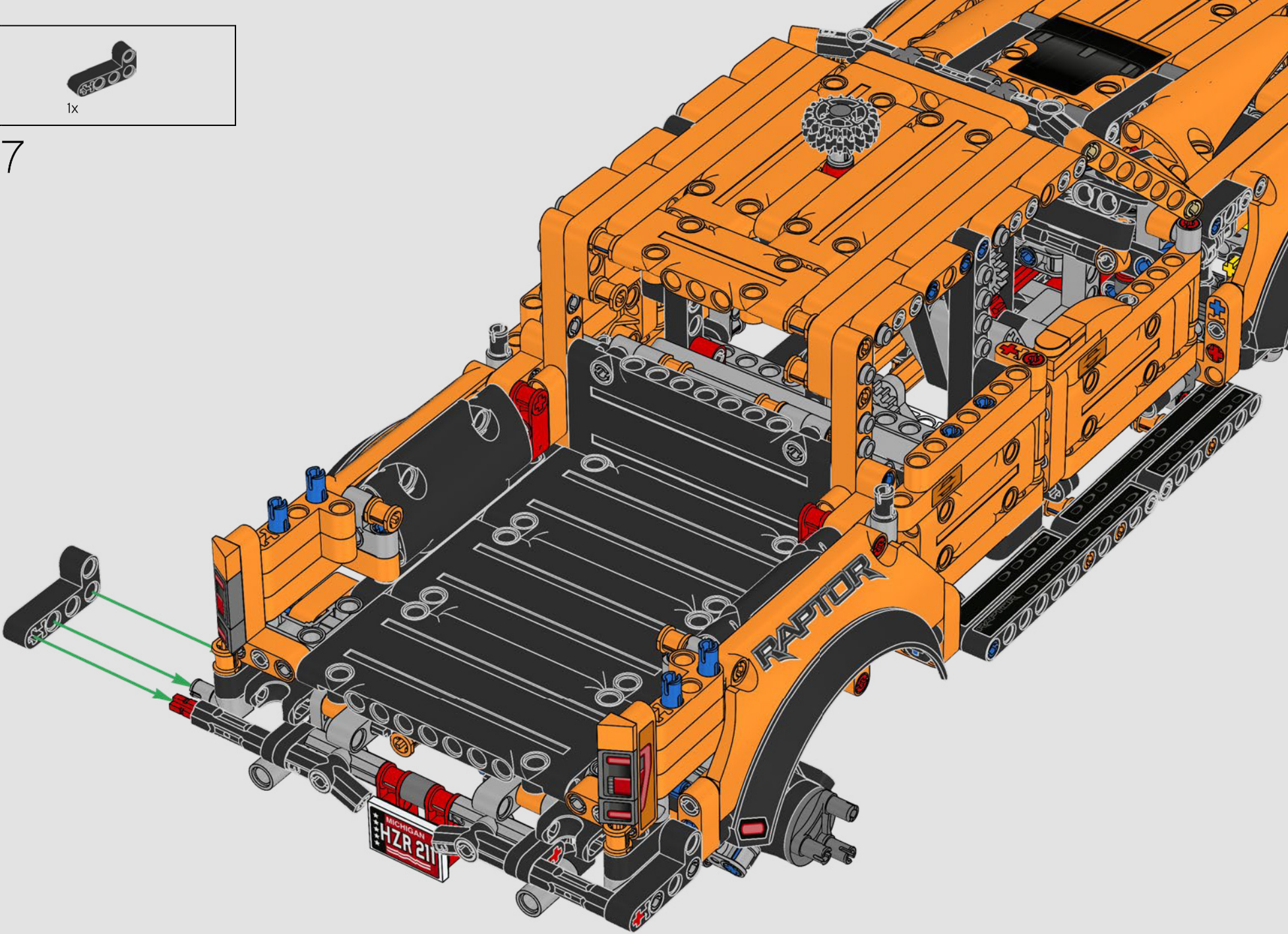

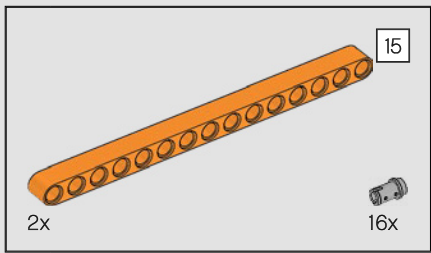

418

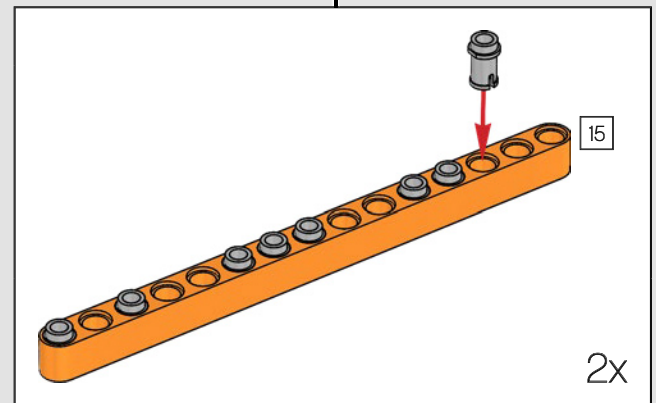
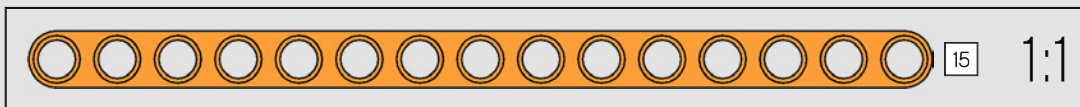
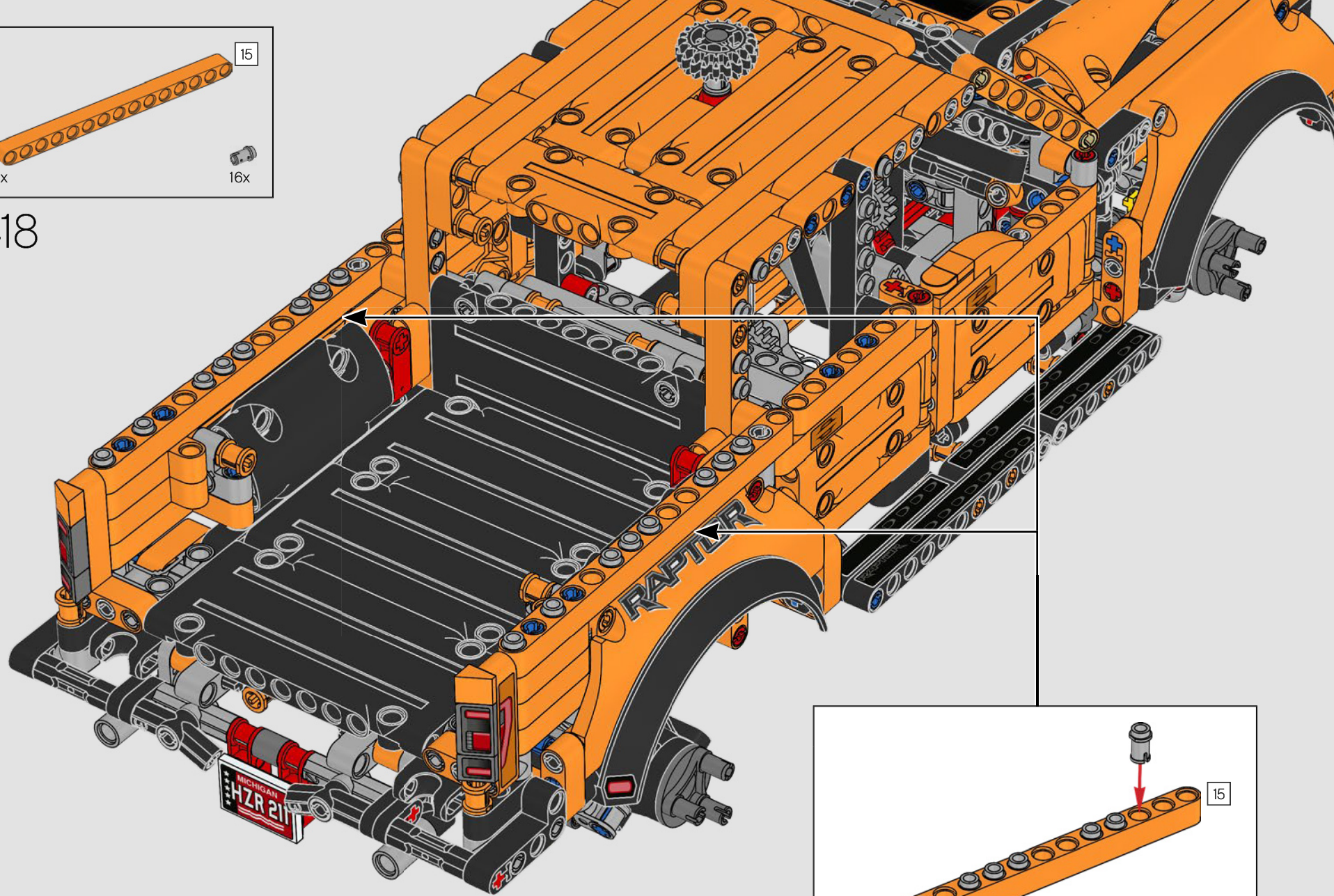

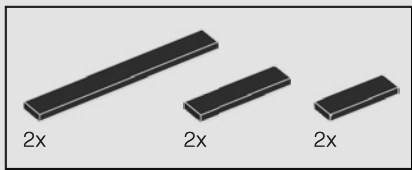

419

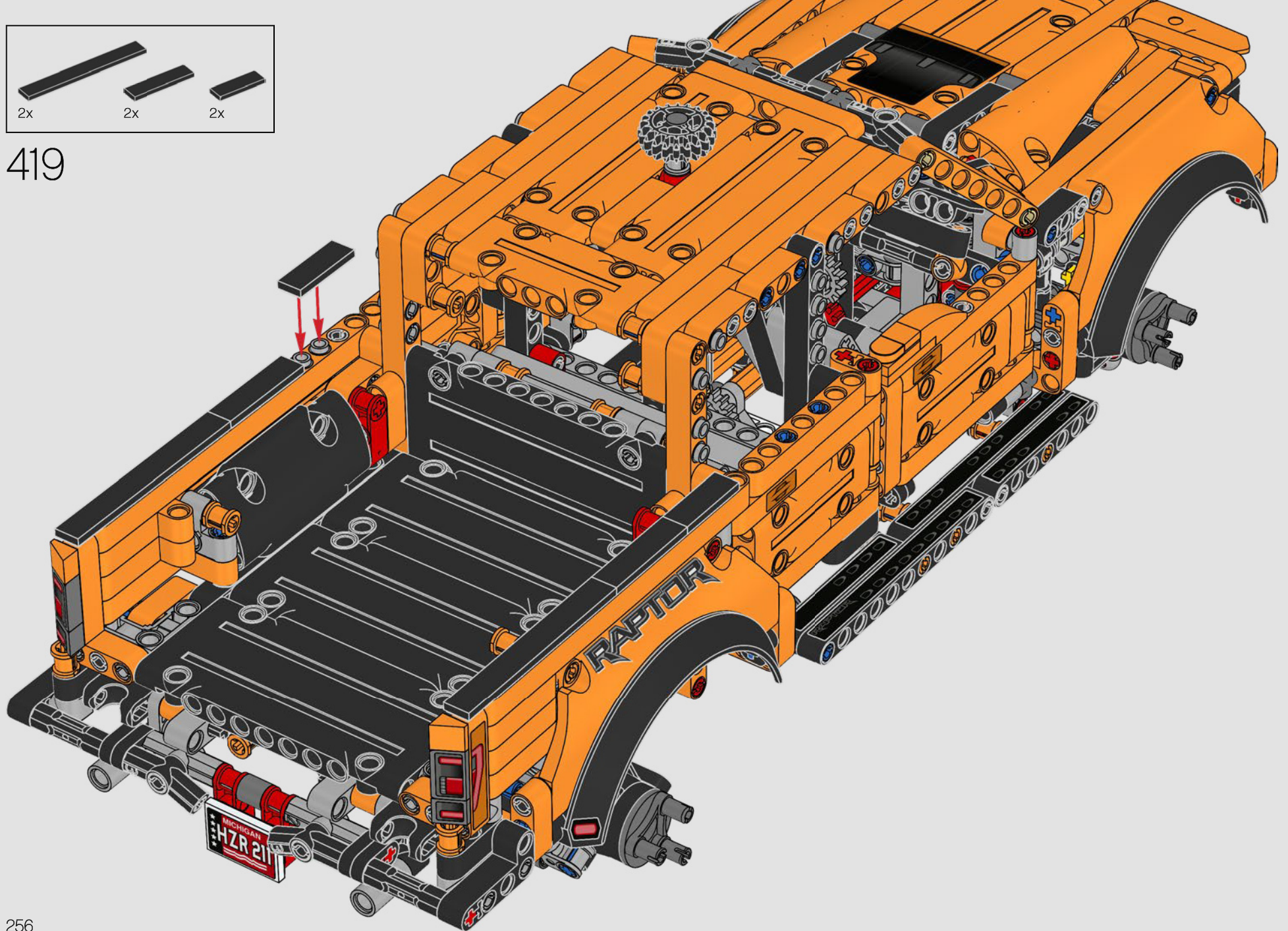

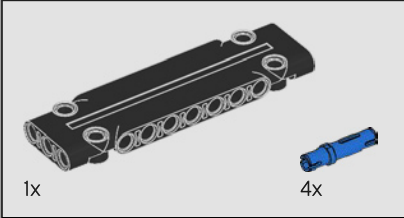
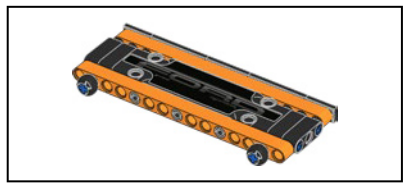

420

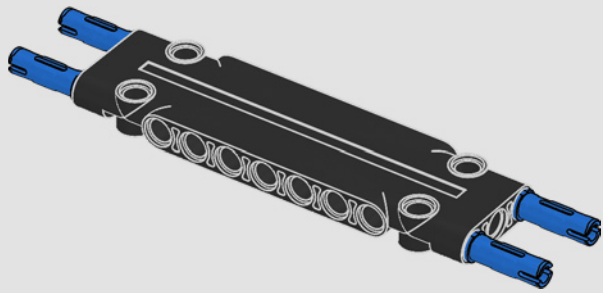

421

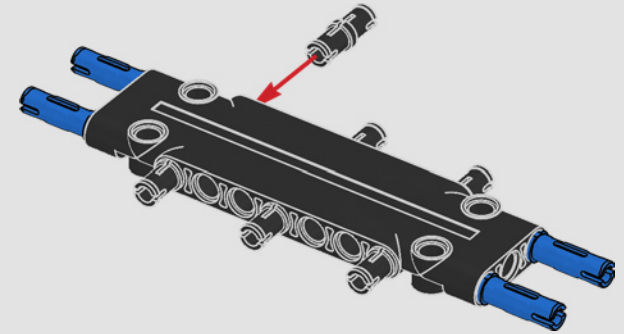

422

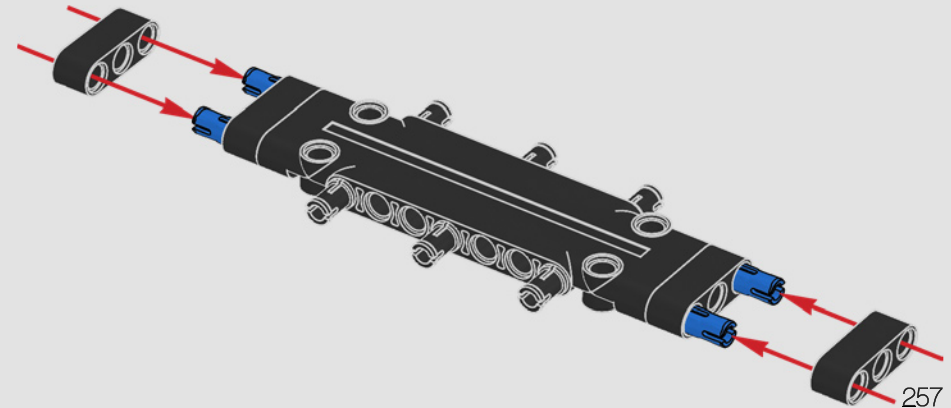

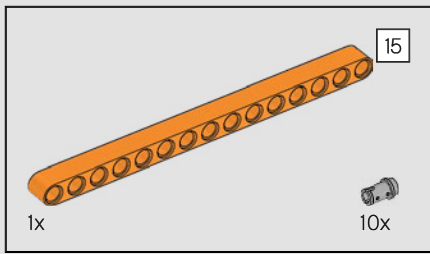

423

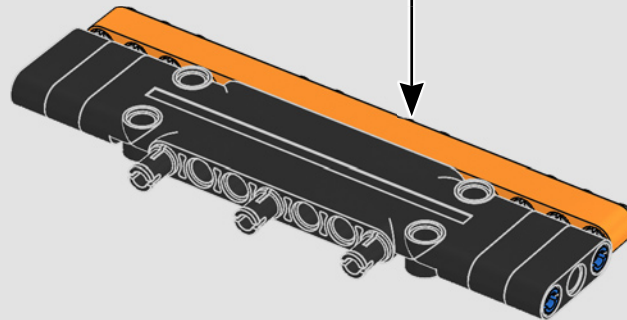
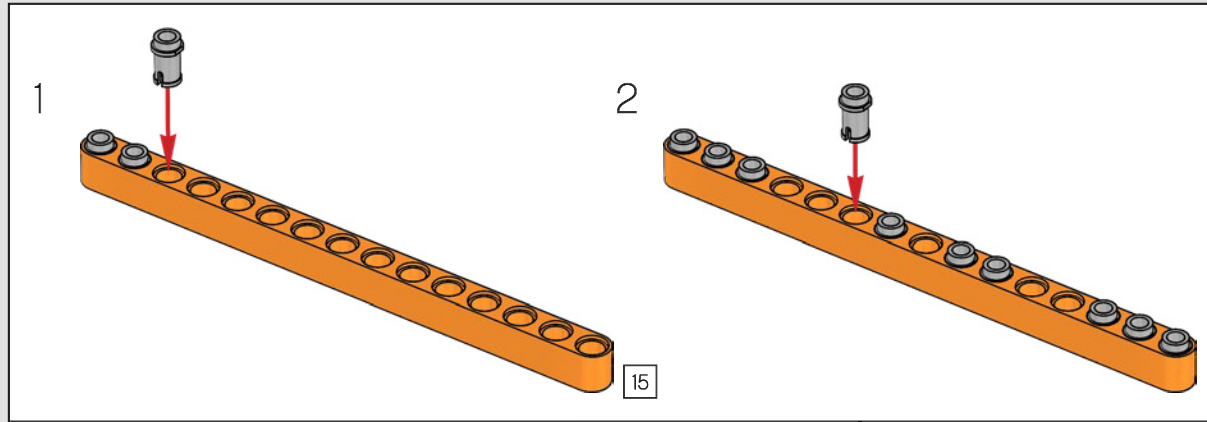
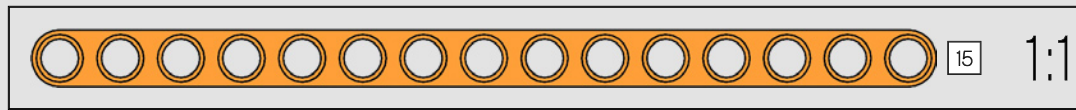

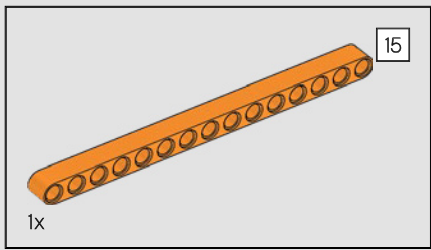

424

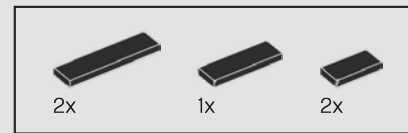
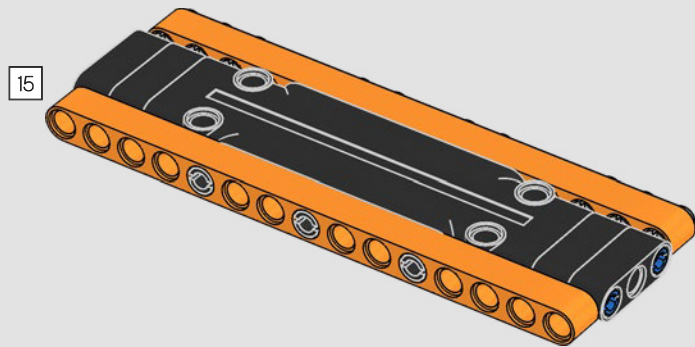

425

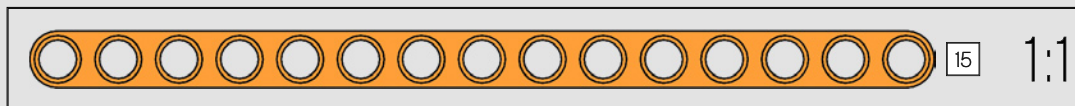
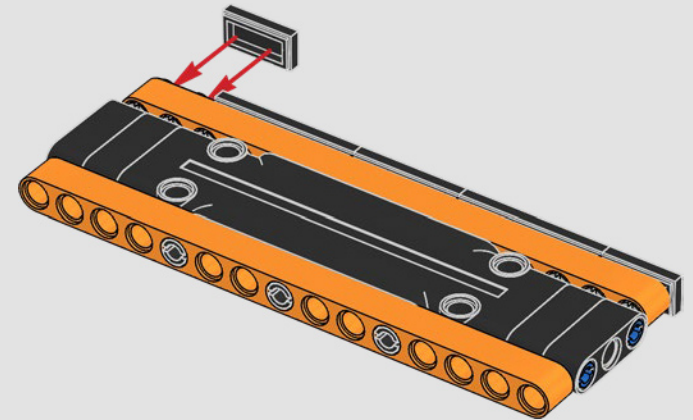

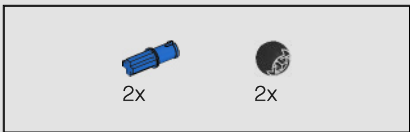

426

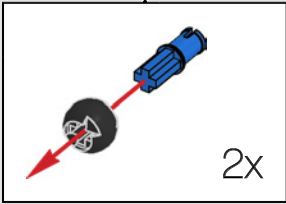
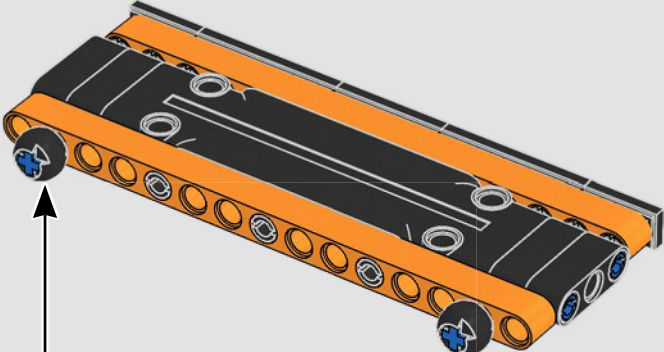

427

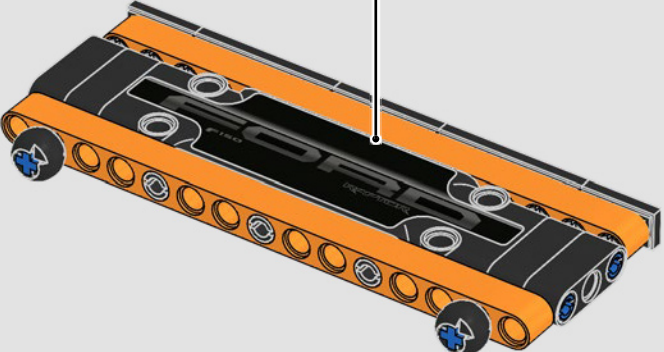

428

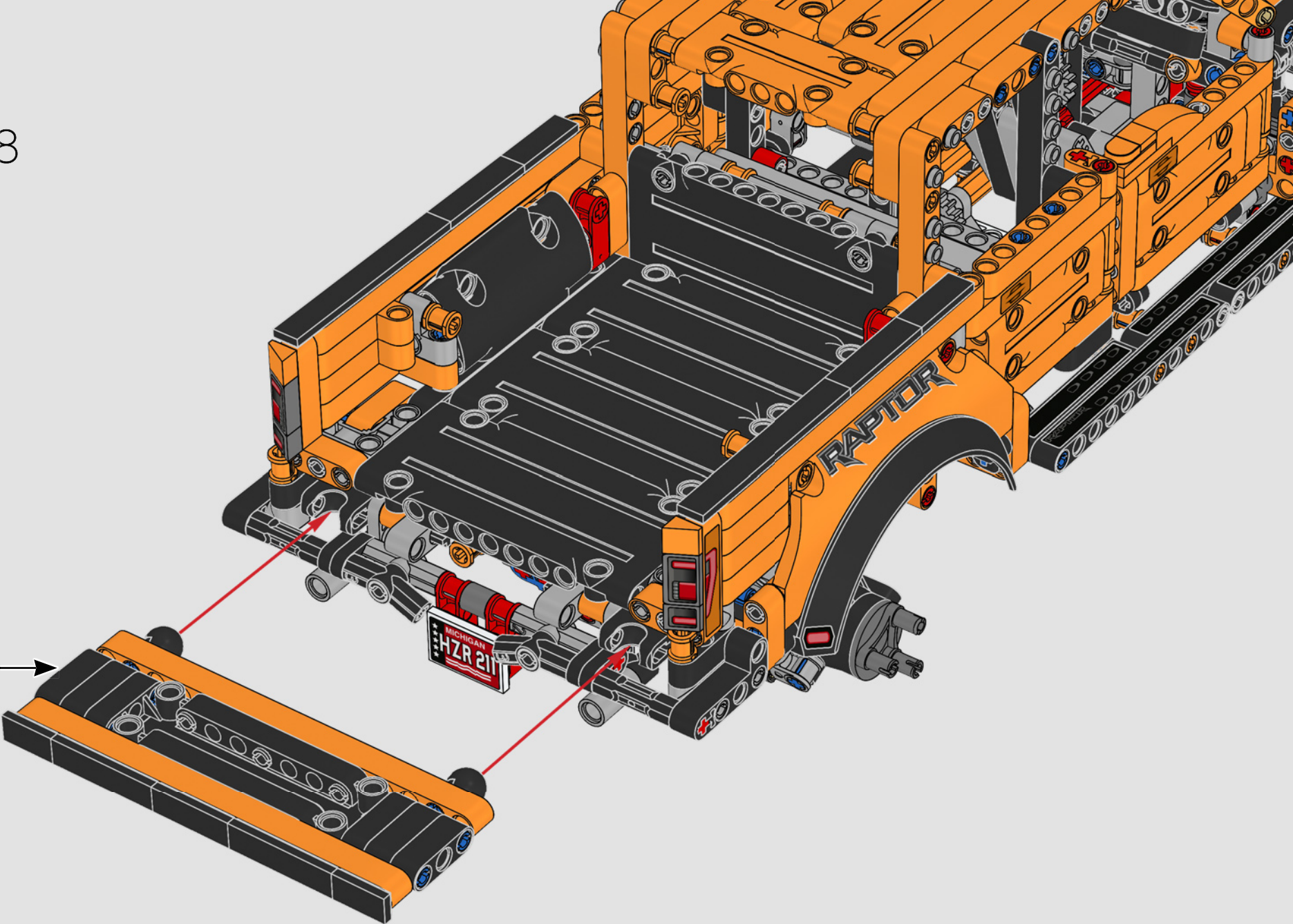

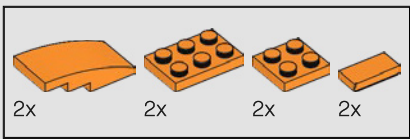

429

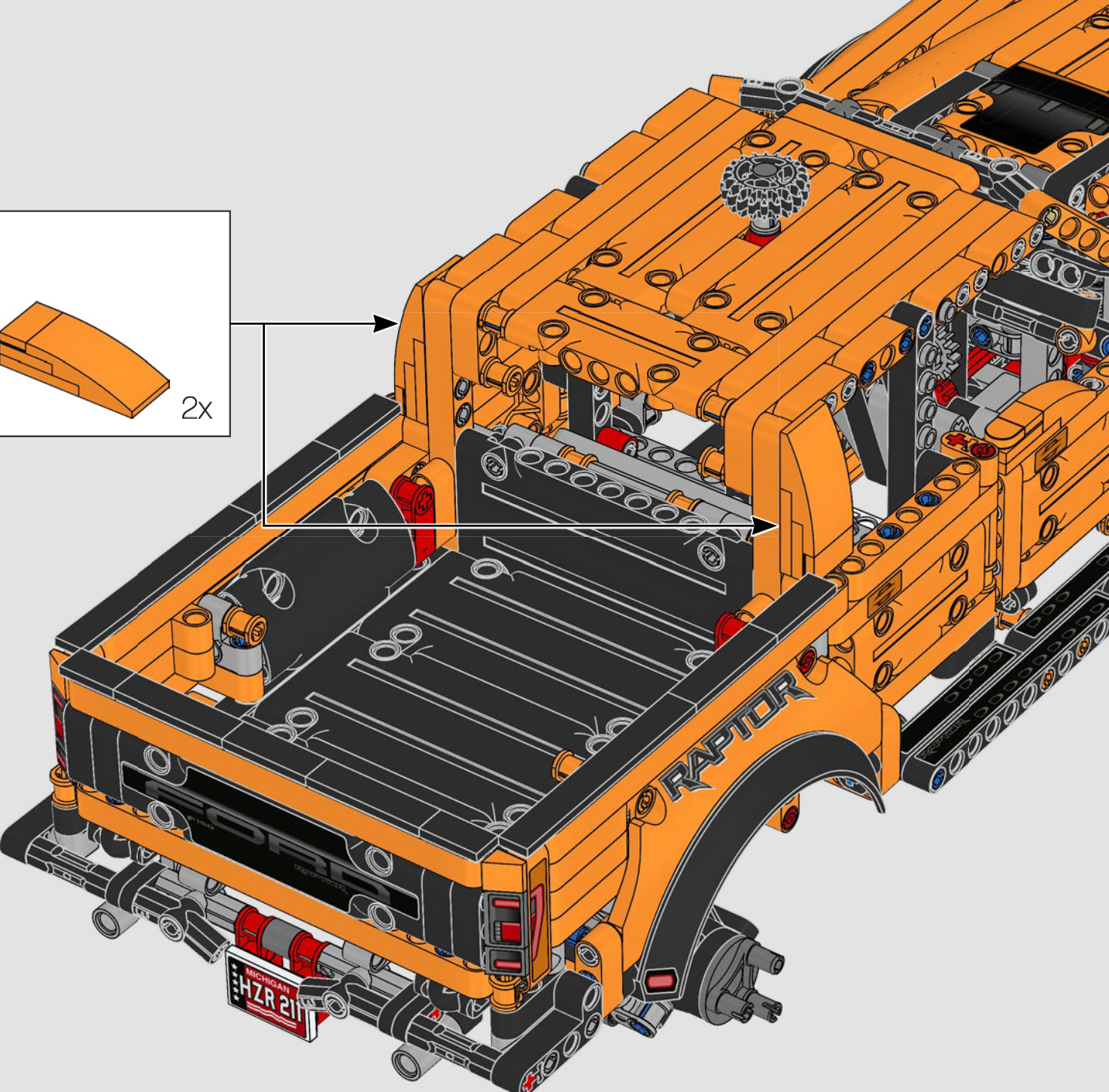
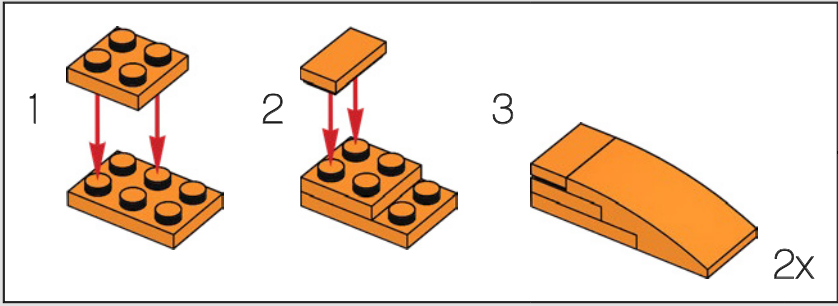

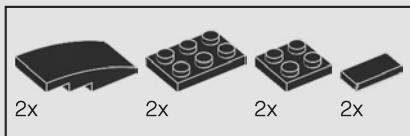

430

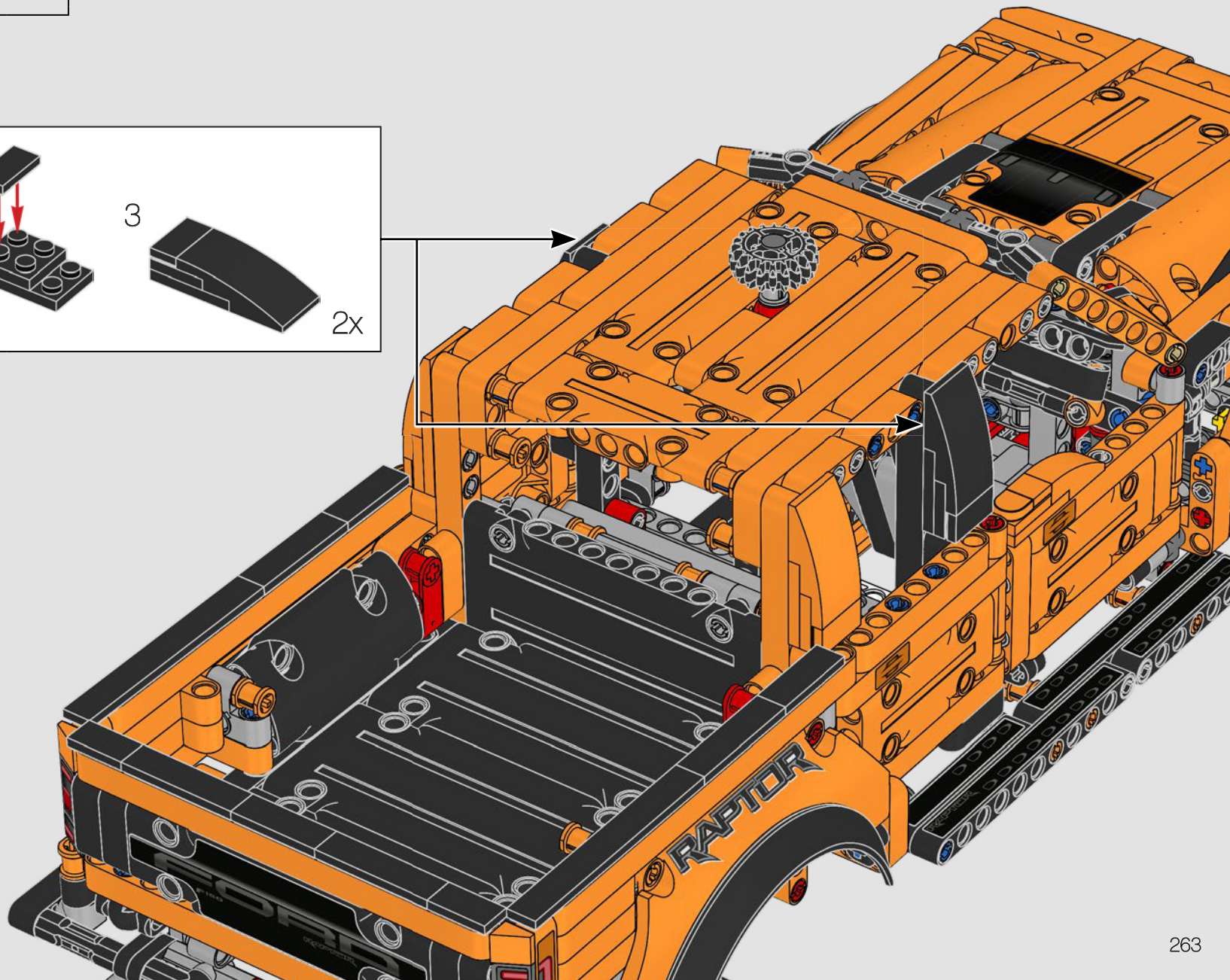
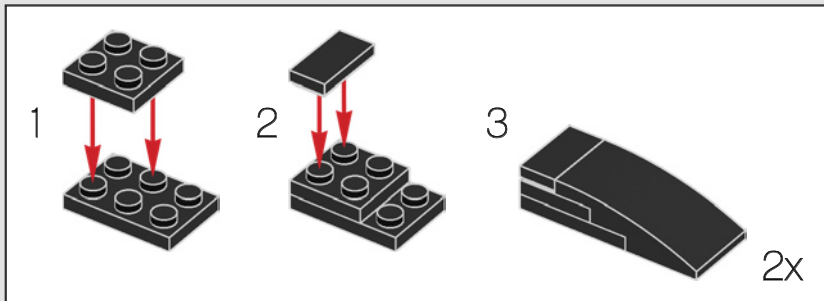

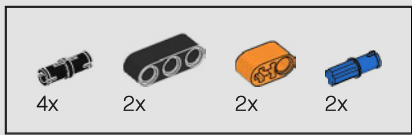

431

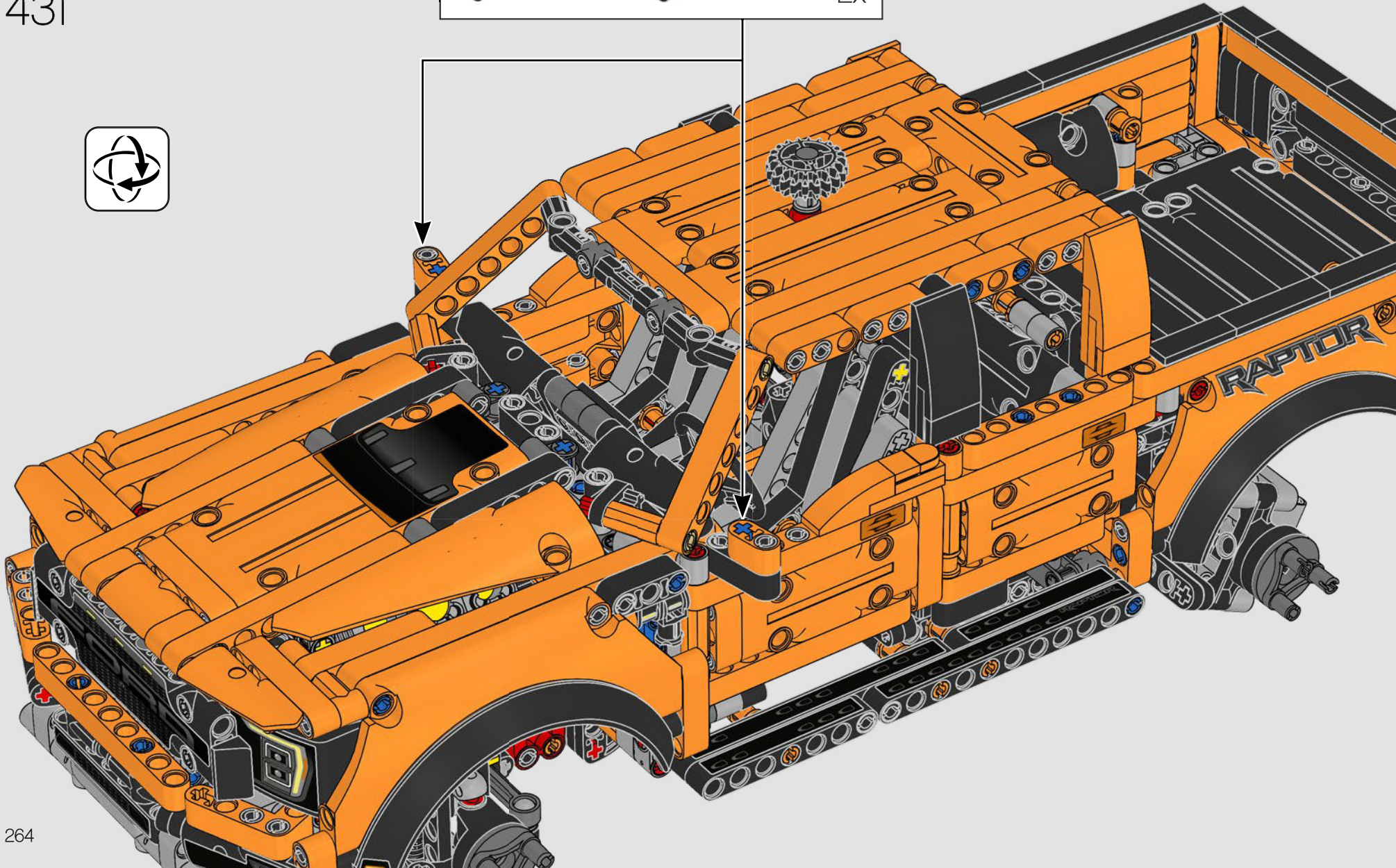
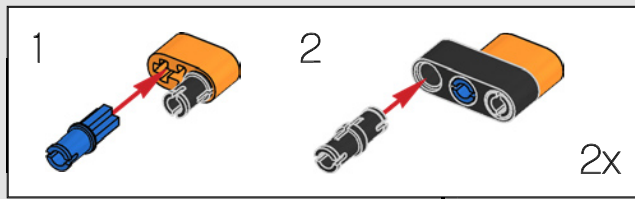

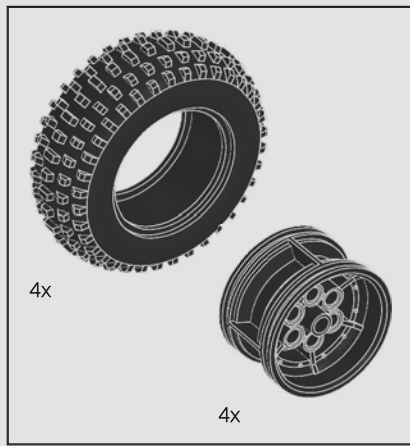

432

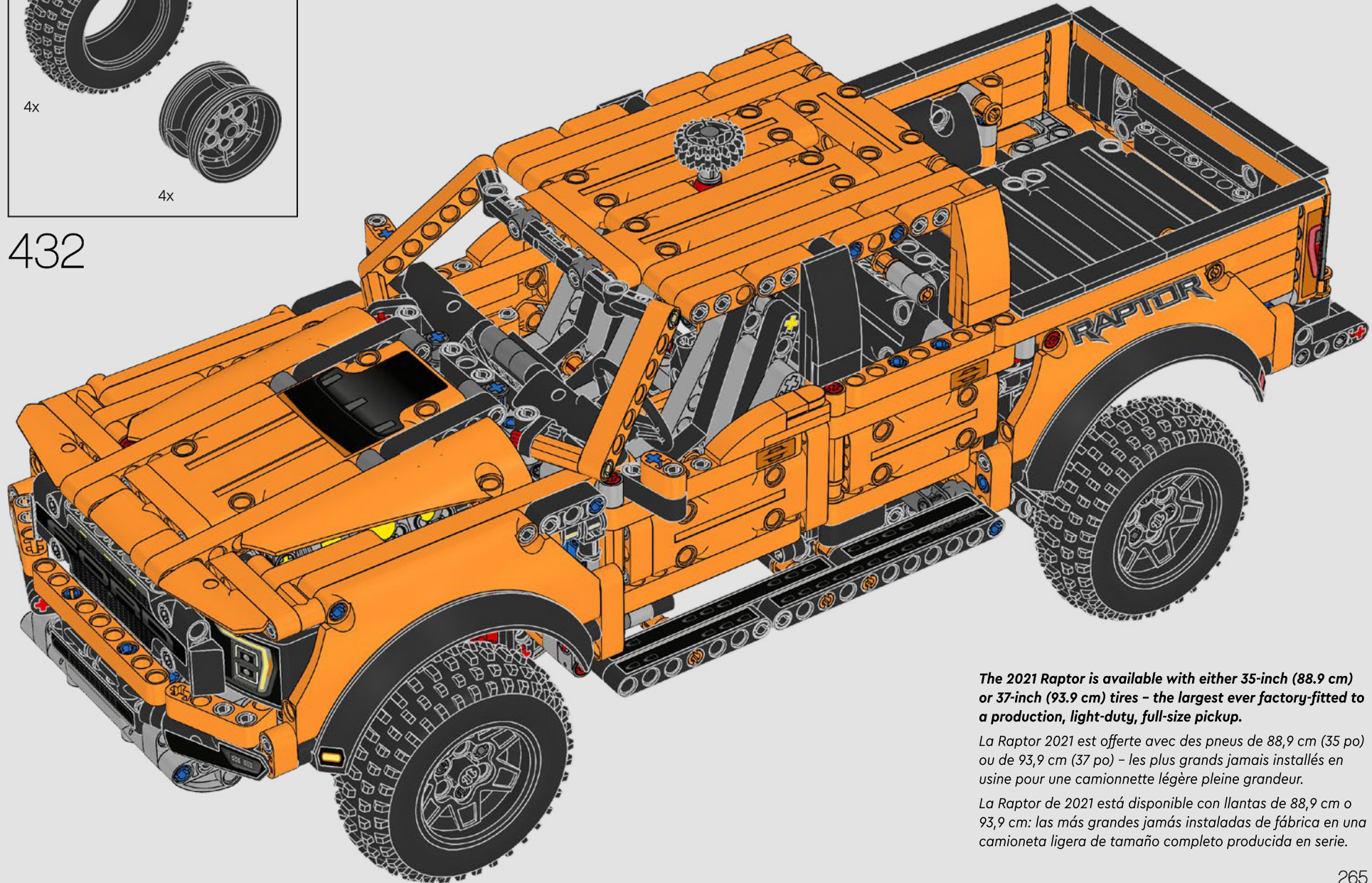

The 2021 Raptor is available with either 35-inch (88.9 cm) or 37-inch (93.9 cm) tires – the largest ever factory-fitted to a production, light-duty, full-size pickup.

La Raptor 2021 est offerte avec des pneus de 88,9 cm (35 po) ou de 93,9 cm (37 po) – les plus grands jamais installés en usine pour une camionnette légère pleine grandeur.

La Raptor de 2021 está disponible con llantas de 88,9 cm o 93,9 cm: las más grandes jamás instaladas de fábrica en una camioneta ligera de tamaño completo producida en serie.



2x
6292916



1x
6156667

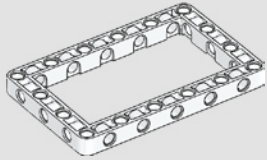

1x
6247435



4x
4565452



2x
6013938



2x
6355727



4x
4666579



8x
6321305



1x
4666999



2x
6135494



2x
6159763

266



1x
6323573



10x
6360104



35x
4142865



4x
6167939



1x
6100930



6x
4173975



2x
6331864



18x
6273712



41x
6209519



3x
6130002



1x
6349634



1x
6130005



1x
6130005



1x
6130005



2x
4286267



2x
4177431



2x
6319983



16x
6338428



2x
6316923



2x
4548180



239x
6279875



4x
6253260



2x
6331716



4x
306926



2x
6346535



2x
6331723



2x
6331723



4x
6336619



2x
302226



22x
6089119



6x
6261386



9x
4552347



11x
4142822



4x
6271869



15x
6362991



3x
6265644



9x
6286381



2x
4610948



3x
4558170



4x
6352693



4x
6327548



1x
6162892



2x
302126



4x
6271825



2x
6172966



4x
243126



1x
6278412



4x
6327028



1x
6299938



2x
4647286



2x
4142135



1x
6271358



2x
6268012



1x
6327430



6x
370526



7x
4495935



4x
6276858



2x
6150082



1x
370726



2x
416226



8x
6271152



1x
6016154



4x
6321710



7x
4542573



3x
6330585



9x
6029578



1x
6214731



3x
6080356



4x
6358257



3x
6330585



9x
6029578



1x
6214731



3x
6080356



4x
6358257



4x
4566243



1x
6321716



7x
4542573



11



11



15



15



15



15



15

3x 6275844
 21x 6282142
 69x 4211483
 2x 4211375
 21x 6261375
 6x 4211880
 2x 6173127
 6x 4640536
 2x 6361459
 6x 6000018
 2x 6360043
 3x 6346487
 3x 6282158
 1x 6335279

6x 4234251
 6x 6313453
 24x 6271831
 4x 6331428
 4x 6247352
 11x 4211639
 16x 4211713
 16x 4211651
 2x 6055519
 1x 6257136
 4x 6279885

1x 6296843
 9x 6102449
 13x 6102449
 3x 4522934
 4x 4629802
 2x 6338588
 2x 6358258
 1x 4580014
 6x 6358259

1x 6358253
 1x 6358255
 2x 4125278
 1x 6358254
 4x 6305545
 12x 6271832
 2x 6054529
 11x 6135086
 2x 6339023

2x 6344851
 6x 6332584
 6x 6259825
 14x 6265128
 20x 6143028
 2x 4251969
 2x 6147047
 3x 6143014
 14x 6143015
 7x 6339024
 5x 6358256

2x 6332570
 53x 4206482
 2x 6331024
 6x 6279026
 128x 6299413
 2x 4558595
 2x 4504371
 1x 6352662
 1x 6340604
 2x 4177932
 2x 4188771
 2x 4159007
 43x 6347790
 17x 6102618

2x 6271167
 6x 4112203
 2x 4119474
 21x 6130007
 1x 6130009
 22x 6100030
 2x 4504378
 2x 4567887
 2x 6280395
 10x 6167281
 1x 6296844

10x 6276984
 4x 4610378
 9x 6083620
 1x 4525184
 3x 4508553
 4x 4629920
 2x 6027566
 2x 6027565

Customer Service
 Kundenservice
 Service Consommateurs
 Servicio Al Consumidor
 LEGO.com/service or dial
 : 00800 5346 5555
 : 1-800-422-5346



FEEDBACK AND WIN



FEEDBACK AND WIN

Your feedback will help shape the future development of this product series.

Please visit:

FEEDBACK UND GEWINNEN

Dein Feedback trägt zur Weiterentwicklung dieser Produktreihe bei.

Geh auf:

COMMENTEZ ET GAGNEZ

Vos commentaires nous aideront à concevoir les futurs produits de cette gamme.

Rendez-vous sur :

COMENTA Y GANA

Tu opinión nos ayudará a dar forma al desarrollo de esta serie de productos en el futuro.

Visita:

反馈有奖

您的反馈将有助于我们在今后改进本系列产品。

请访问：

[LEGO.com/productfeedback](https://www.lego.com/productfeedback)

By completing, you will automatically enter a drawing to win a LEGO® set.

Terms & Conditions apply.

Durch Ausfüllen nimmst du automatisch an der Verlosung eines LEGO® Preises teil.

Es gelten die Teilnahmebedingungen.

En envoyant vos commentaires, vous serez automatiquement inscrit(e) à un tirage au sort qui vous permettra de remporter un prix LEGO®.

Offre soumise à conditions.

Al contestar, participarás automáticamente en el sorteo y podrás ganar un set LEGO®.

Sujeto a Términos y Condiciones.

完成我们的反馈调查，即可自动进入抽奖环节，赢取乐高®套装。

适用《条款和条件》。

LEGO and the LEGO logo are trademarks of the/son des marques de commerce du/son marcas registradas de LEGO Group. ©2021 The LEGO Group.
Ford Trademarks and Trade Dress used under license to The LEGO Group of companies.

